

FOR QUESTIONS, CALL THE
 FLD AIRE NATIONAL
 REGION 22
 PHONE: (610) 239-8405
 EMAIL: courtney.hardin@floaire.com

PATENT NUMBERS

AC-PSP (UNITED STATES) - US PATENT 7963830 B2.
 AC-PSP WALL (CANADA) - CA PATENT 2820509.
 AC-PSP ISLAND (CANADA) - CA PATENT 2520330.

HOOD INFORMATION - JOB#5910325

HOOD NO	TAG	MODEL	MANUFACTURER	LENGTH	MAX COOKING TEMP	TYPE	APPLIANCE DUTY	DESIGN CFM/FT	TOTAL EXH CFM	EXHAUST PLENUM RISER(S)						TOTAL SUPPLY CFM	HOOD CONSTRUCTION	HOOD CONFIG		
										WIDTH	LENG	HEIGHT	DIA	CFM	VEL			SP	END TO END	ROW
1	10' Nonheated	5424 FX-2-PSP-F	FLD AIRE	10' 0"	600 DEG	I	HEAVY	234	2340	10'	22'	4'		2340	1532	-0.984'	1872	430 SS WHERE EXPOSED	ALONE	ALONE

HOOD INFORMATION

HOOD NO	TAG	TYPE	FILTER(S)				LIGHT(S)			UTILITY CABINET(S)				FIRE SYSTEM PIPING	HOOD HANGING WEIGHT						
			QTY	HEIGHT	LENGTH	EFFICIENCY @ 7 MICRONS	QTY	TYPE	WIRE GUARD	LOCATION	SIZE	FIRE SYSTEM				ELECTRICAL	SWITCHES				
1	10' Nonheated	CAPTRATE SOLID FILTER	7	16"	16'	85% SEE FILTER SPEC	3	L55 SERIES E26	NO	RIGHT	12"x54"x24"							SC-111110MA	1 LIGHT 1 FAN	NO	685 LBS

HOOD OPTIONS

HOOD NO	TAG	OPTION
1	10' Nonheated	RIGHT VERTICAL END PANEL 27' TOP WIDTH, 21' BOTTOM WIDTH, 80' HIGH INSULATED 430 SS.
		LEFT VERTICAL END PANEL 27' TOP WIDTH, 21' BOTTOM WIDTH, 80' HIGH INSULATED 430 SS.
		SENSOR-CV.

PERFORATED SUPPLY PLENUM(S)

HOOD NO	TAG	POS	LENGTH	WIDTH	HEIGHT	TYPE	RISER(S)				
							WIDTH	LENG	DIA	CFM	SP
1	10' Nonheated	Front	132'	16"	6"	MUA	8"	36"		624	0.174'
						MUA	8"	36"		624	0.174'
						MUA	8"	36"		624	0.174'

SPECIFICATION: CAPTRATE® GREASE-STOP® SOLID FILTER

THE CAPTRATE GREASE-STOP SOLID FILTER IS A SINGLE-STAGE FILTER FEATURING A UNIQUE S-BAFFLE DESIGN IN CONJUNCTION WITH A SLOTTED REAR BAFFLE DESIGN, TO DELIVER EXCEPTIONAL FILTRATION EFFICIENCY.

FILTER IS STAINLESS STEEL CONSTRUCTION, AND SIZED TO FIT INTO STANDARD 2-INCH DEEP HOOD CHANNEL(S).

UNITS SHALL INCLUDE STAINLESS STEEL HANDLES AND A FASTENING DEVICE TO SECURE THE TWO COMPONENTS WHEN ASSEMBLED.

GREASE EXTRACTION EFFICIENCY PERFORMANCE SHALL REMOVE AT LEAST 75% OF GREASE PARTICLES FIVE MICRONS IN SIZE, AND 85% GREASE PARTICLES SEVEN MICRONS IN SIZE AND LARGER, WITH A CORRESPONDING PRESSURE DROP NOT TO EXCEED 1.0 INCHES OF WATER GAUGE. THE CAPTRATE GREASE-STOP SOLID WAS TESTED TO ASTM STANDARD ASTM F2519-05. MANUFACTURER APPROVED FOR USE IN SOLID FUEL APPLICATIONS AS A SPARK ARRESTER.

EFFICIENCY VS. PARTICLE DIAMETER

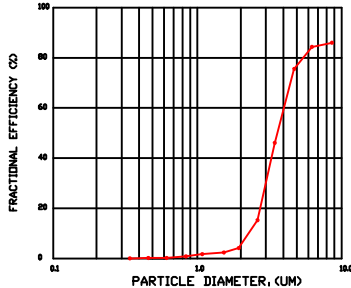

PRESSURE DROP VS. FLOW RATE

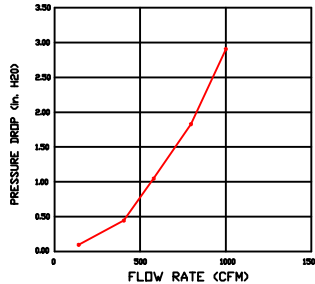

CAPTRATE FILTERS ARE BUILT IN COMPLIANCE WITH:
 NFPA #96.
 NSF STANDARD #2.
 UL STANDARD #1046.
 INT. MECH. CODE (IMC).
 ULC-S649.

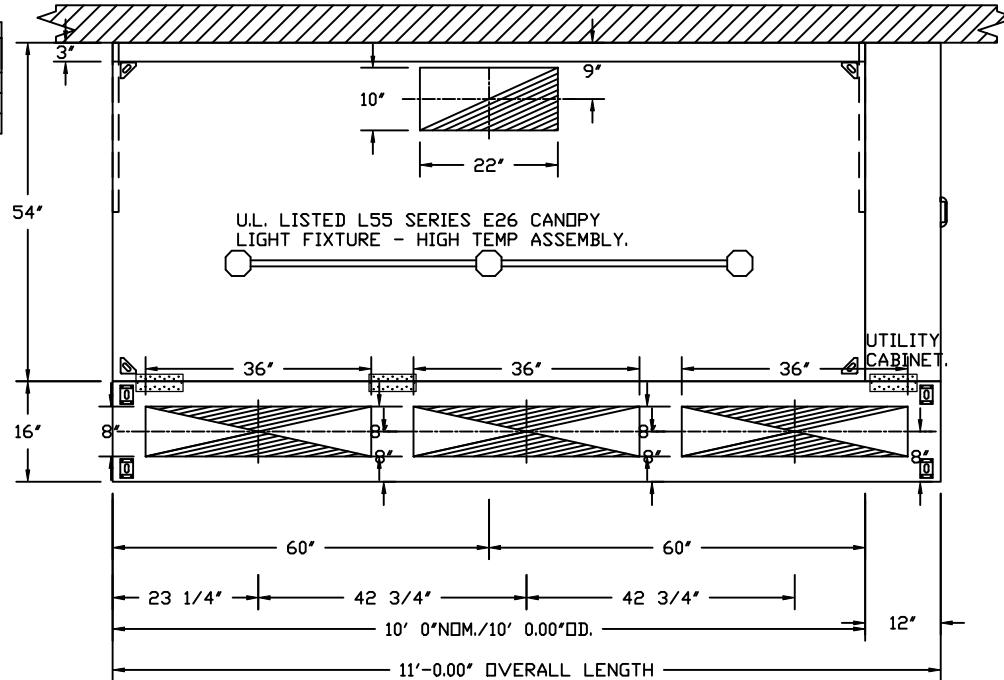

PLAN VIEW - HOOD #1 (10' Nonheated)
 10' 0.00" LONG 5424FX-2-PSP-F



FloAire

JOB 10' Nonheated UC Right** Hood Stock	
LOCATION	
DATE 3/20/2023	JOB # 5910325
DWG # 1	DRAWN BY courtneyh
REV.	SCALE 3/8" = 1'-0"

HOOD CORNER HANGING ANGLE (HARDWARE BY INSTALLER)

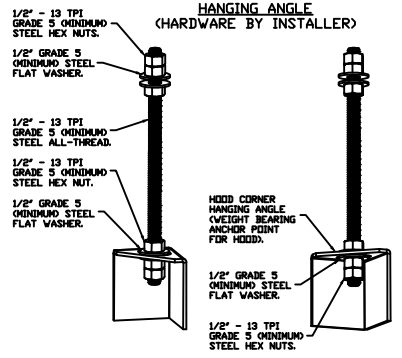

ASSEMBLY INSTRUCTIONS

HANGING ANGLE MUST BE SUPPORTED WITH 1/2" - 13 TPI GRADE 5 (MINIMUM) ALL-THREAD. SANDWICH HANGING ANGLES AND CEILING ANCHOR POINTS WITH 1/2" GRADE 5 (MINIMUM) STEEL FLAT WASHERS AND 1/2" - 13 TPI GRADE 5 (MINIMUM) HEX NUTS AS SHOWN. MUST USE DOUBLED HEX NUT CONFIGURATION BENEATH HOOD HANGING ANGLES AND ABOVE CEILING ANCHORS. MAINTAIN 1/4" OF EXPOSED THREADS BENEATH BOTTOM HEX NUT. TORQUE ALL HEX NUTS TO 57 FT-LBS.

FULL LENGTH HANGING ANGLE (HARDWARE BY INSTALLER)

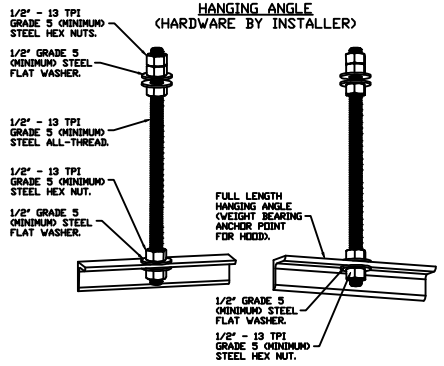

ASSEMBLY INSTRUCTIONS

HANGING ANGLE MUST BE SUPPORTED WITH 1/2" - 13 TPI GRADE 5 (MINIMUM) ALL-THREAD. SANDWICH HANGING ANGLES AND CEILING ANCHOR POINTS WITH 1/2" GRADE 5 (MINIMUM) STEEL FLAT WASHERS AND 1/2" - 13 TPI GRADE 5 (MINIMUM) HEX NUTS AS SHOWN. MUST USE DOUBLED HEX NUT CONFIGURATION ABOVE CEILING ANCHORS. SINGLE HEX NUT BENEATH HANGING ANGLE IS ACCEPTABLE FOR FULL LENGTH HANGING ANGLES. MAINTAIN 1/4" OF EXPOSED THREADS BENEATH BOTTOM HEX NUT. TORQUE ALL HEX NUTS TO 57 FT-LBS.

SUPPLY PLENUM HANGING ANGLE (HARDWARE BY INSTALLER)

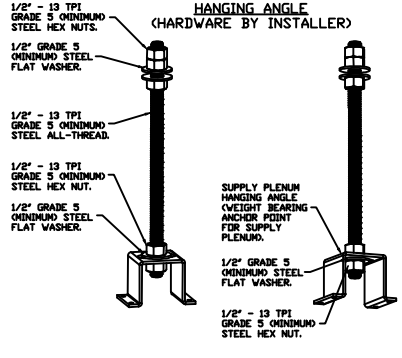

ASSEMBLY INSTRUCTIONS

HANGING ANGLE MUST BE SUPPORTED WITH 1/2" - 13 TPI GRADE 5 (MINIMUM) ALL-THREAD. SANDWICH HANGING ANGLES AND CEILING ANCHOR POINTS WITH 1/2" GRADE 5 (MINIMUM) STEEL FLAT WASHERS AND 1/2" - 13 TPI GRADE 5 (MINIMUM) HEX NUTS AS SHOWN. MUST USE DOUBLED HEX NUT CONFIGURATION ABOVE CEILING ANCHORS. SINGLE HEX NUT BENEATH HANGING ANGLE IS ACCEPTABLE FOR PSP HANGING ANGLES. MAINTAIN 1/4" OF EXPOSED THREADS BENEATH BOTTOM HEX NUT. TORQUE ALL HEX NUTS TO 57 FT-LBS.



FloAire

JOB10' Nonheated UC Right** Hood Stock	
LOCATION ,	
DATE 3/20/2023	JOB # 5910325
DWG # 2	DRAWN BY courtneyh
REV.	SCALE 3/8" = 1'-0"

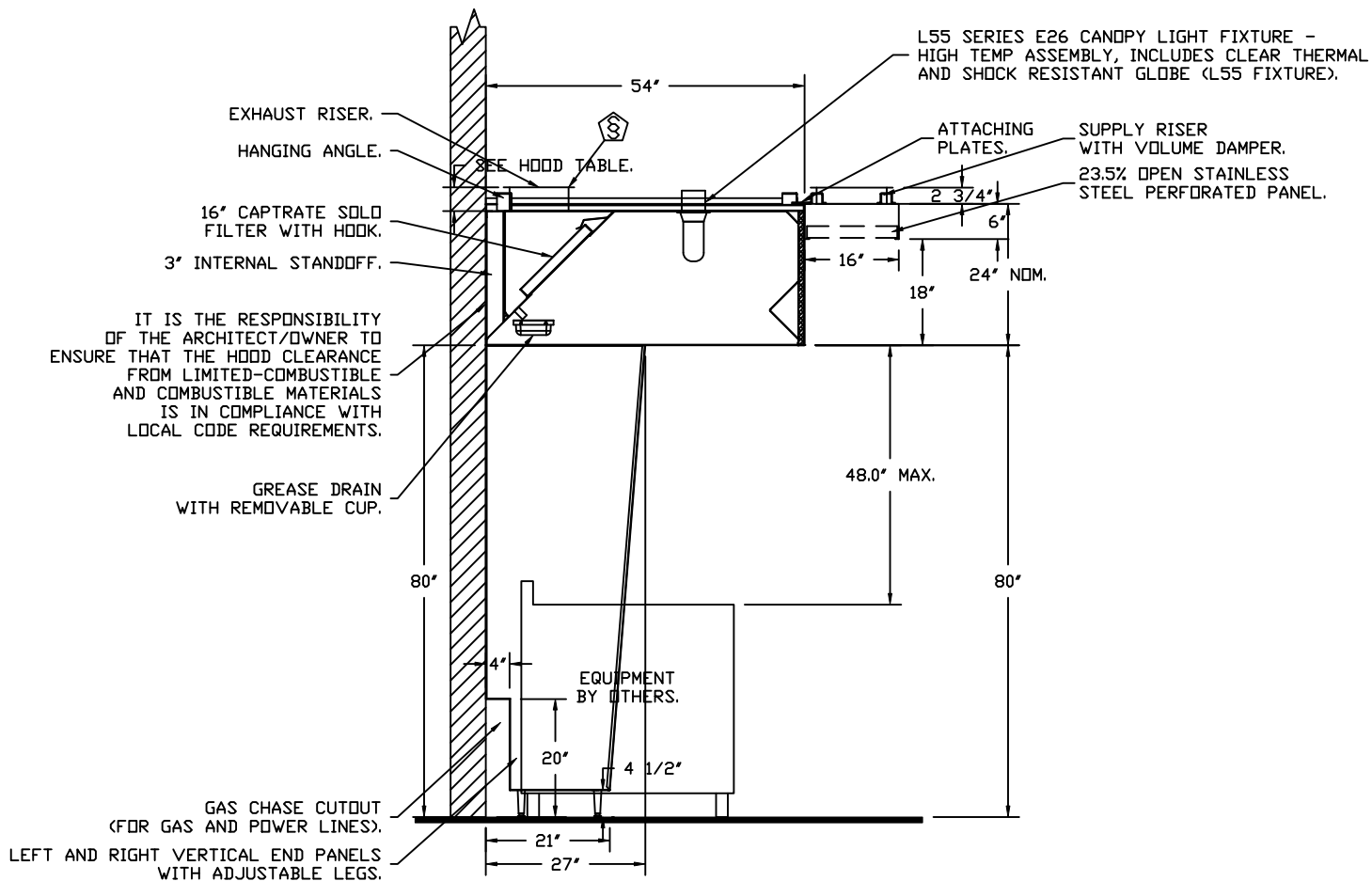

**SECTION VIEW - MODEL 5424FX-2-PSP-F
HOOD - #1 (10' Nonheated)**



FloAire

JOB 10' Nonheated UC Right** Hood Stock	
LOCATION ,	
DATE 3/20/2023	JOB # 5910325
DWG # 3	DRAWN BY courtneyh
REV.	SCALE 3/8" = 1'-0"

EXHAUST FAN INFORMATION - JOB#5910325

FAN UNIT NO	TAG	QTY	FAN UNIT MODEL #	MANUFACTURER	CFM	ESP	RPM	MOTOR ENCL	HP	BHP	PHASE	VOLT	FLA	DISCHARGE VELOCITY	WEIGHT (LBS)	SONES
1	10' NONHEATED	1	DUB5H	FLOAIRE	2340	1.100	1588	TEAD-ECM	1.000	0.7240	1	115	11.6	741 FPM	98	17.2

MUA FAN INFORMATION - JOB#5910325

FAN UNIT NO	TAG	QTY	FAN UNIT MODEL #	BLOWER	HOUSING	MIN CFM	DESIGN CFM	ESP	RPM	MOTOR ENCL	HP	BHP	PHASE	VOLT	FLA	MCA	MDCP	WEIGHT (LBS)	SONES
2	10' NONHEATED	1	SA10	G10D	A1	-	1872	0.300	788	TEAD-ECM	1.000	0.3890	1	115	11.6	15.6A	25A	244	15

FAN OPTIONS

FAN UNIT NO	TAG	QTY	DESCRIPTION
1	10' NONHEATED	1	GREASE BOX
		1	HINGE KIT - SHIPS LOOSE FOR CURB SUPPLIED BY OTHERS
		1	ECM WIRING PACKAGE - EXHAUST - MODBUS CONTROL -MSC- (TELCD), CCW ROTATION
		1	2 YEAR PARTS WARRANTY
2	10' NONHEATED	1	MOTORIZED BACKDRAFT DAMPER FOR SIZE 1 HOUSING - MEETS AMCA CLASS 1A RATING
		1	SIZE 1 UNTEMPERED COMMERCIAL DOWN DISCHARGE FOR DIRECT DRIVE AHUS
		1	ECM WIRING PACKAGE-SUPPLY - MODBUS CONTROL -MSC- (TELCD), CW ROTATION
		1	2 YEAR PARTS WARRANTY

FAN ACCESSORIES

FAN UNIT NO	TAG	EXHAUST				SUPPLY		
		GREASE CUP	GRAVITY DAMPER	WALL MOUNT	SIDE DISCHARGE	GRAVITY DAMPER	MOTORIZED DAMPER	WALL MOUNT
1	10' NONHEATED	YES						
2	10' NONHEATED					YES		

CURB ASSEMBLIES

NO	DN FAN	TAG	WEIGHT	ITEM	SIZE
1	# 1	10' NONHEATED	32 LBS	CURB	23.000"W X 23.000"L X 20.000"H ALONG LENGTH, RIGHT VENTED.
2	# 2	10' NONHEATED	29 LBS	CURB	21.000"W X 21.000"L X 20.000"H ALONG LENGTH, RIGHT.

FAN SOUND DATA

FAN UNIT NO	TAG	MOTOR	SOUND DATA			OCTAVE BAND SOUND DATA								
			LWA	SONES @ 5 FT	DBA @ 5 FT	DISTANCE (FT)	63 HZ	125 HZ	250 HZ	500 HZ	1 KHZ	2 KHZ	4 KHZ	8 KHZ
1	10' NONHEATED	EXHAUST	80.5	17.1767011270497	69	5	81.2	81.2	84.9	76.8	72.9	71.1	67.8	61.6
2	10' NONHEATED	SUPPLY	78.5	14.9519830203381	67	5	80.8	78.8	77.2	74.1	73.6	71.6	66.7	63.7



FloAire

JOB10' Nonheated UC Right** Hood Stock	
LOCATION ,	
DATE 3/20/2023	JOB # 5910325
DWG # 4	DRAWN BY courtneyh
REV.	SCALE 3/8" = 1'-0"

FAN #1 DU85H - EXHAUST FAN (10' NONHEATED)

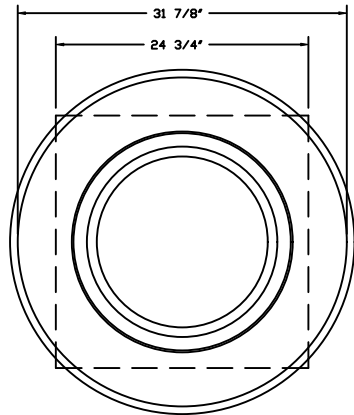
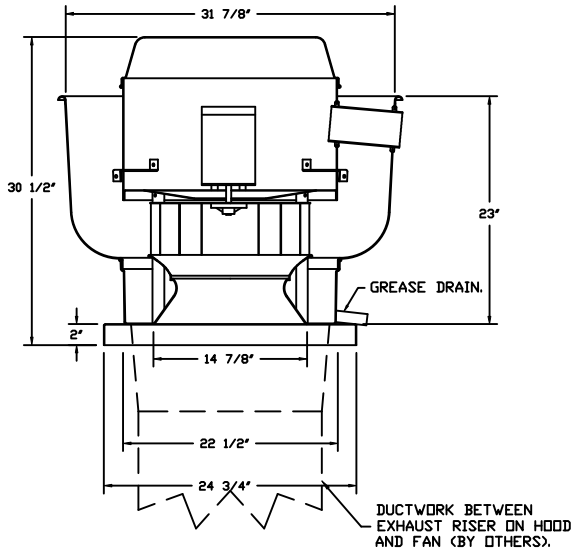

TOP VIEW

FEATURES:

- DIRECT DRIVE CONSTRUCTION (NO BELTS/PULLEYS).
- ROOF MOUNTED FANS.
- RESTAURANT MODEL.
- UL705 AND UL762 AND ULC-S645
- VARIABLE SPEED CONTROL.
- INTERNAL WIRING.
- THERMAL OVERLOAD PROTECTION (SINGLE PHASE).
- HIGH HEAT OPERATION 300°F (149°C).
- GREASE CLASSIFICATION TESTING.
- NEMA 3R SAFETY DISCONNECT SWITCH.

NORMAL TEMPERATURE TEST
 EXHAUST FAN MUST OPERATE CONTINUOUSLY WHILE EXHAUSTING AIR AT 300°F (149°C) UNTIL ALL FAN PARTS HAVE REACHED THERMAL EQUILIBRIUM, AND WITHOUT ANY DETERIORATING EFFECTS TO THE FAN WHICH WOULD CAUSE UNSAFE OPERATION.

ABNORMAL FLARE-UP TEST
 EXHAUST FAN MUST OPERATE CONTINUOUSLY WHILE EXHAUSTING BURNING GREASE VAPORS AT 600°F (316°C) FOR A PERIOD OF 15 MINUTES WITHOUT THE FAN BECOMING DAMAGED TO ANY EXTENT THAT COULD CAUSE AN UNSAFE CONDITION.

OPTIONS

- GREASE BOX.
- HINGE KIT - SHIPS LOOSE FOR CURB SUPPLIED BY OTHERS.
- ECM WIRING PACKAGE - EXHAUST - MODBUS CONTROL
- MSC- (TELCO), CCW ROTATION.
- 2 YEAR PARTS WARRANTY.

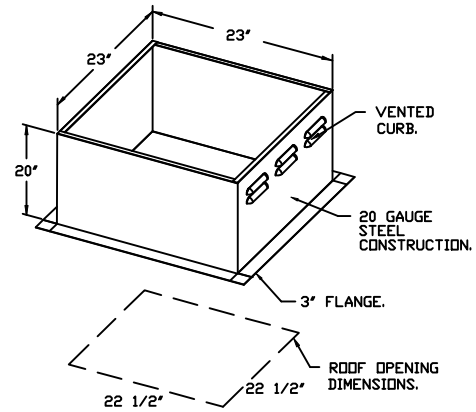

FloAire

JOB10' Nonheated UC Right** Hood Stock	
LOCATION ,	
DATE 3/20/2023	JOB # 5910325
DWG # 5	DRAWN BY courtneyh
REV.	SCALE 3/8" = 1'-0"

FAN#1 (10' NONHEATED) - EXHAUST PERFORMANCE CURVES.

2340 CFM, 1.1 SP @ 1588 RPM AND 0.724 BHP AT 0 FEET AND 120 DEG F.
 * PLEASE NOTE THAT THESE CURVES WERE ADJUSTED FOR JOB SPECIFIC TEMPERATURE AND ALTITUDE.

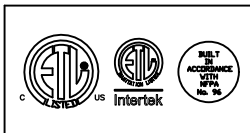
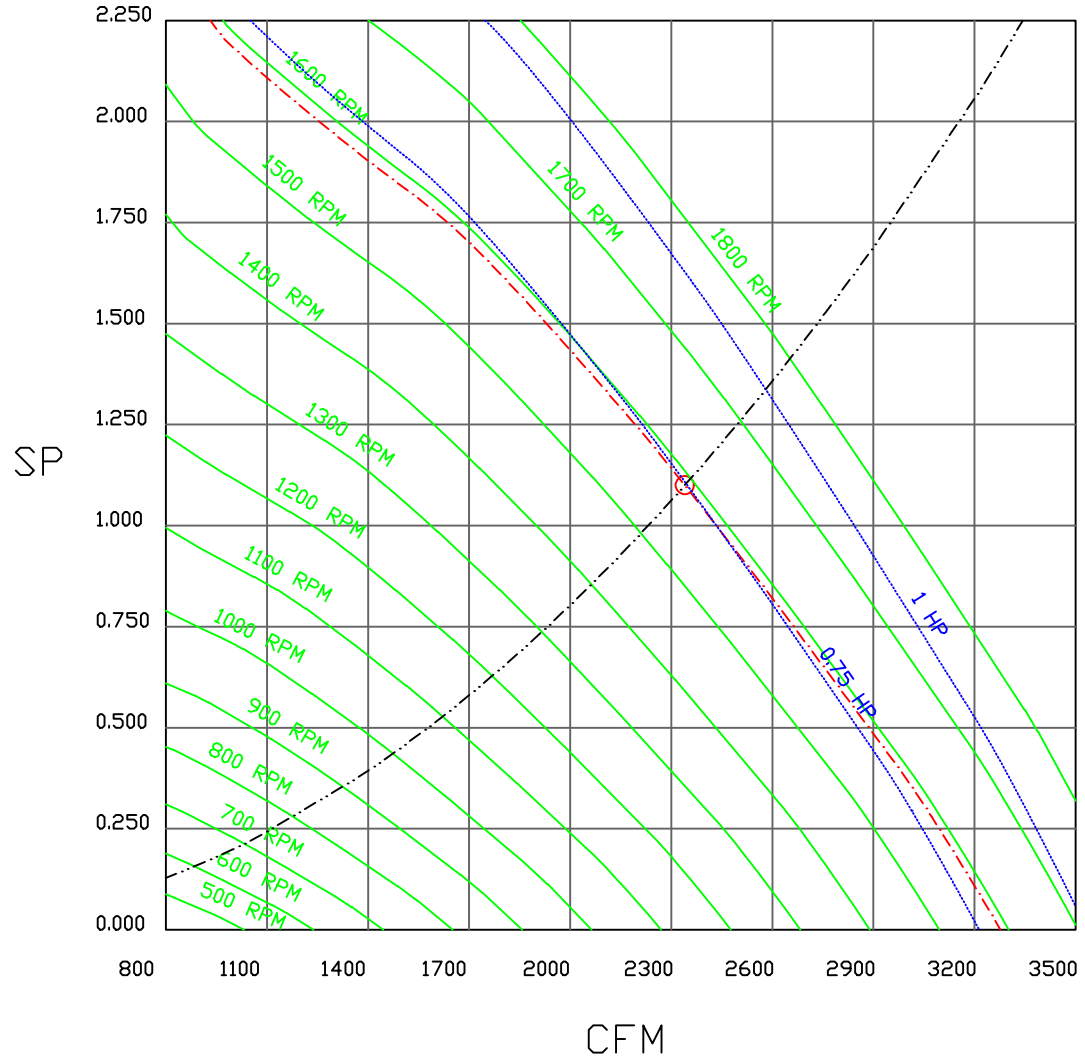

FloAire

JOB10' Nonheated UC Right** Hood Stock	
LOCATION ,	
DATE 3/20/2023	JOB # 5910325
DWG # 6	DRAWN BY courtneyh
REV.	SCALE 3/8" = 1'-0"

FAN #2 SA10D - SUPPLY FAN (10' NONHEATED)

1. DIRECT DRIVE UNTEMPERED SUPPLY UNIT WITH 10' BLOWER IN SIZE #1 HOUSING WITH SPEED CONTROL, DISCONNECT SWITCH.
2. INTAKE HOOD WITH E2 FILTERS.
3. DOWN DISCHARGE - AIR FLOW RIGHT -> LEFT.
4. MOTORIZED BACK DRAFT DAMPER 16" X 18" FOR SIZE 1 UNTEMPERED UNITS W/EXTENDED SHAFT, STANDARD GALVANIZED CONSTRUCTION, 3/4" REAR FLANGE, LOW LEAKAGE, TFB120S ACTUATOR INCLUDED.
5. DOWN DISCHARGE CONSTRUCTION FOR SIZE 1 UNTEMPERED DIRECT DRIVE AHUS.
6. ECM WIRING PACKAGE MODBUS CONTROL FOR SUPPLY EC MOTORS. MSC CONTROLLER. **DO NOT ORDER UNDER WARRANTY, SEE PART NUMBER CAS MSC**.**
7. HINGED DOUBLE WALL INSULATED DDDR ASSEMBLY (BURNER/BLOWER SECTION).
8. 2 YEAR PARTS WARRANTY

NOTE: SUPPLY DUCT MUST BE INSTALLED TO MEET SMACNA STANDARDS. A MINIMUM STRAIGHT DUCT LENGTH MUST BE MAINTAINED DOWNSTREAM OF UNIT DISCHARGE AS OUTLINED IN AMCA PUBLICATION 201. WHEN USING RECTANGULAR DUCTWORK, ELBOWS MUST BE RADIUS THROAT, RADIUS BACK WITH TURNING VANES. FLEXIBLE DUCTWORK AND SQUARE THROAT/SQUARE BACK ELBOWS SHOULD NOT BE USED. ANY TRANSITION AND/OR TURNS IN THE DUCTWORK WILL CAUSE SYSTEM EFFECT. SYSTEM EFFECT WILL DRASTICALLY INCREASE STATIC PRESSURE AND REDUCE AIRFLOW. DO NOT RELY ON UNIT TO SUPPORT DUCT IN ANY WAY. FAILURE TO PROPERLY SIZE DUCTWORK MAY CAUSE SYSTEM EFFECTS AND REDUCE PERFORMANCE OF THE EQUIPMENT. SUGGESTED STRAIGHT DUCT SIZE IS 14" X 14".

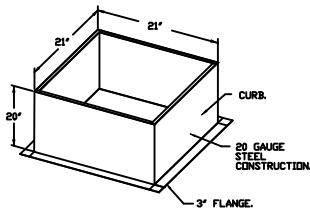
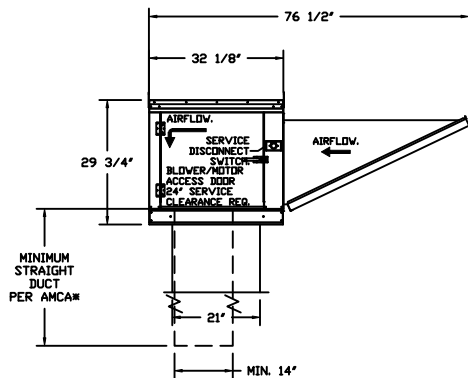
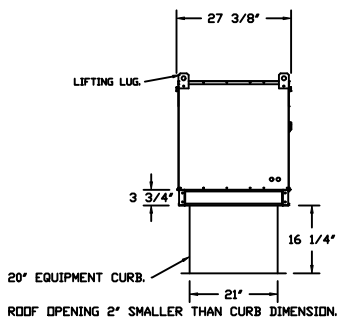
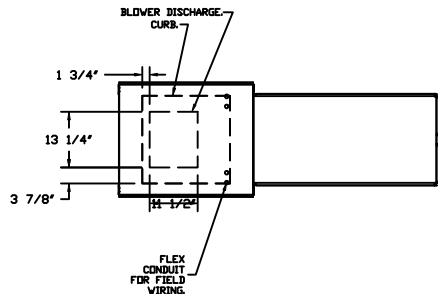

FloAire

JOB10' Nonheated UC Right** Hood Stock	
LOCATION ,	
DATE 3/20/2023	JOB # 5910325
DWG # 7	DRAWN BY courtneyh
REV.	SCALE 1/4" = 1'-0"

FAN#2 (10' NONHEATED) - SUPPLY PERFORMANCE CURVES.

1872 CFM, 0.367 SP @ 788 RPM AND 0.389 BHP AT 0 FEET AND 70 DEG F.
 * PLEASE NOTE THAT THESE CURVES WERE ADJUSTED FOR JOB SPECIFIC TEMPERATURE AND ALTITUDE.

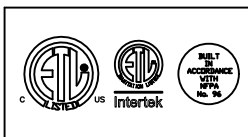
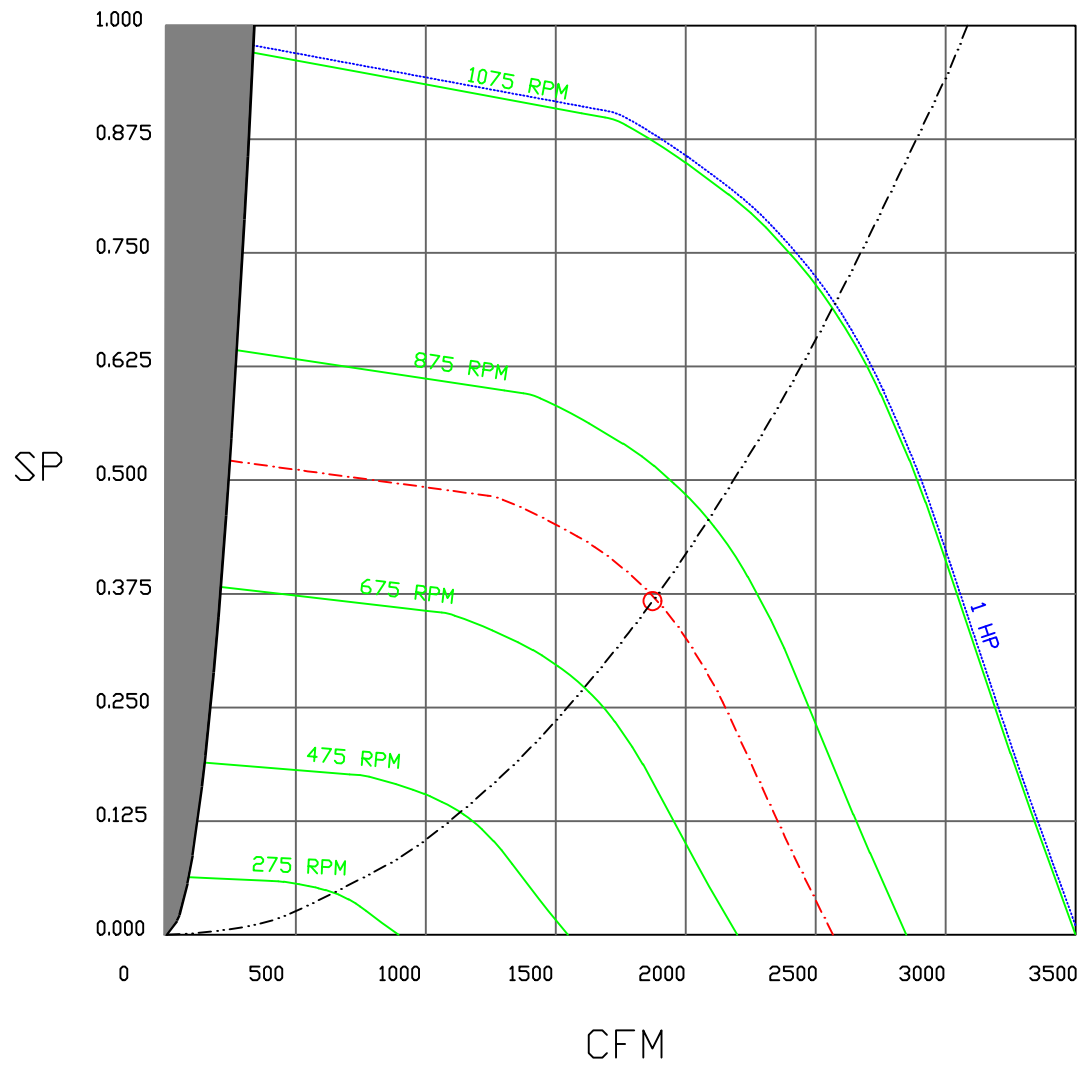

FloAire

JOB 10' Nonheated UC Right** Hood Stock	
LOCATION ,	
DATE 3/20/2023	JOB # 5910325
DWG # 8	DRAWN BY courtneyh
REV.	SCALE 3/8" = 1'-0"



GREASE DUCT & CHIMNEY SPECIFICATIONS:

PROVIDE GREASE DUCT EQUAL TO FLOAIRE MODEL "FDW"
ROUND 20 GAUGE 430 STAINLESS STEEL DUCTWORK. MODEL "FDW"
IS LISTED TO UL-1978 AND IS INSTALLED USING "V" CLAMP LOCKING
CONNECTIONS SEALED WITH 3M FIRE BARRIER 2000 PLUS. MODEL "FDW"
DOES NOT REQUIRE WELDING PROVIDING IT HAS BEEN INSTALLED PER
THE MANUFACTURES INSTALLATION GUIDE.

PROVIDE RATED ACCESS DOORS AT EVERY CHANGE IN DIRECTION AND EVERY 12' ON CENTER.
PER MANUFACTURES LISTING MODEL "FDW" HORIZONTAL RUNS LESS THAN 75 FT. CAN BE
SLOPED 1/16" PER 12", HORIZONTAL RUNS MORE THAN 75 FT. CAN BE SLOPED 3/16" PER 12".
DUCT SHOULD BE SLOPED AS MUCH AS POSSIBLE TO REDUCE THE CHANCE OF GREASE
ACCUMULATION IN HORIZONTAL RUNS.

IF THE DUCT OR CHIMNEY IS WITHIN 18 INCHES OF COMBUSTIBLE MATERIAL, PROVIDE
UL-2221 OR UL-103 HT LISTED DOUBLE WALL GREASE DUCT OR DOUBLE WALL CHIMNEY
EQUAL TO FLOAIRE MODEL "FDW- 2R, 2R TYPE HT, 3R, OR 3Z" ROUND 20 GAUGE 430
STAINLESS INNER DUCT INSULATED WITH A 24 GAUGE 430 STAINLESS OUTER SHELL.

CUSTOMER APPROVAL TO MANUFACTURE:

APPROVED AS NOTED	<input type="checkbox"/>
APPROVED WITH NO EXCEPTION TAKEN	<input type="checkbox"/>
REVISE AND RESUBMIT	<input type="checkbox"/>
SIGNATURE _____	
YOUR TITLE _____	DATE _____



FloAire

JOB 10' Nonheated UC Right** Hood Stock	
LOCATION ,	
DATE 3/20/2023	JOB # 5910325
DWG # 9	DRAWN BY courtneyh
REV.	SCALE 3/8" = 1'-0"

GREASE BOX INSTALLATION

GREASEBOX
REV.#2 08/19/02

PARTS INCLUDED

- GREASE BOX.
- GREASE BOX COVER.
- GREASE PIPE.
- SHEET METAL SCREWS
3 - LONG (3/4" LG.).

GREASE BOX FIELD INSTALLATION

STEP 1)

ATTACH GREASE BOX COVER TO THE CURB, HOLD 3" DIMENSION AS SHOWN ON PIC. 1. SCREW GREASE BOX COVER TO CURB USING (3) LONG (3/4" LG.) SCREWS AS SHOWN ON PIC. 2.

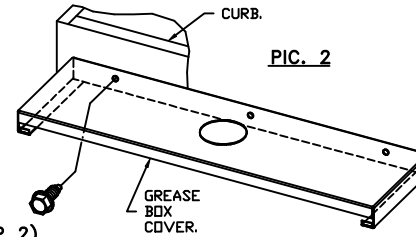
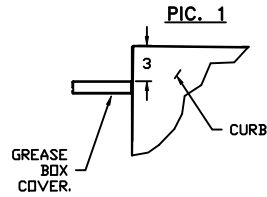

STEP 2)

ATTACH GREASE BOX TO GREASE BOX COVER, SLIDE AND DROP AS SHOWN ON PIC. 3.

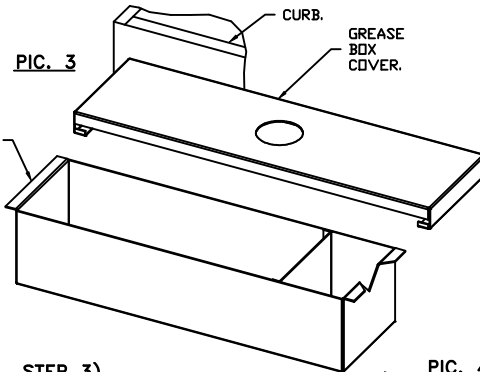

STEP 3)

INSTALL GREASE PIPE AS SHOWN ON PIC. 4.

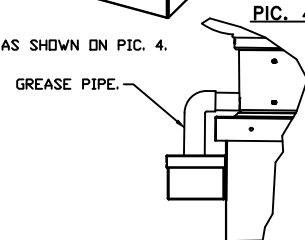

CLOSED POSITION

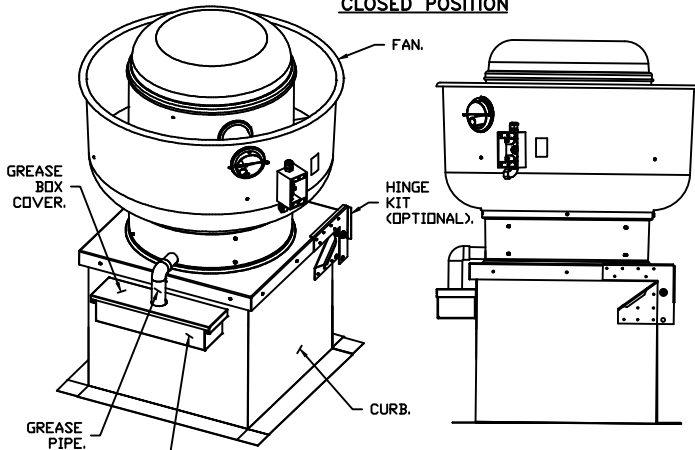

OPEN POSITION

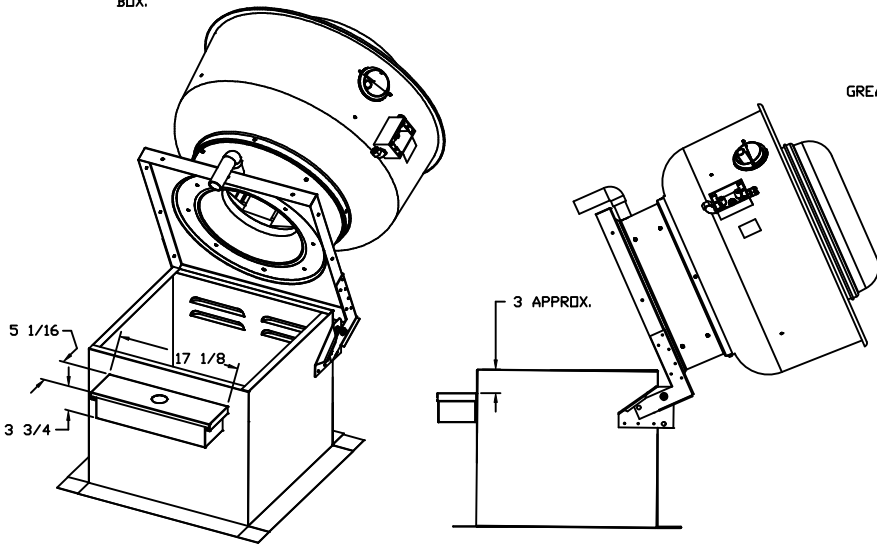

*NOTE: UL 705 INSTALL.



FloAire

JOB 10' Nonheated UC Right** Hood Stock	
LOCATION ,	
DATE 3/20/2023	JOB # 5910325
DWG # 10	DRAWN BY courtneyh
REV.	SCALE 3/8" = 1'-0"

Exhaust Fan Wiring

JOB 5910325 - 10' Nonheated UC Right** Hood..

DRAWING NUMBER EXH5910325-1

SHIP DATE 3/20/2023

MODEL DUB5H

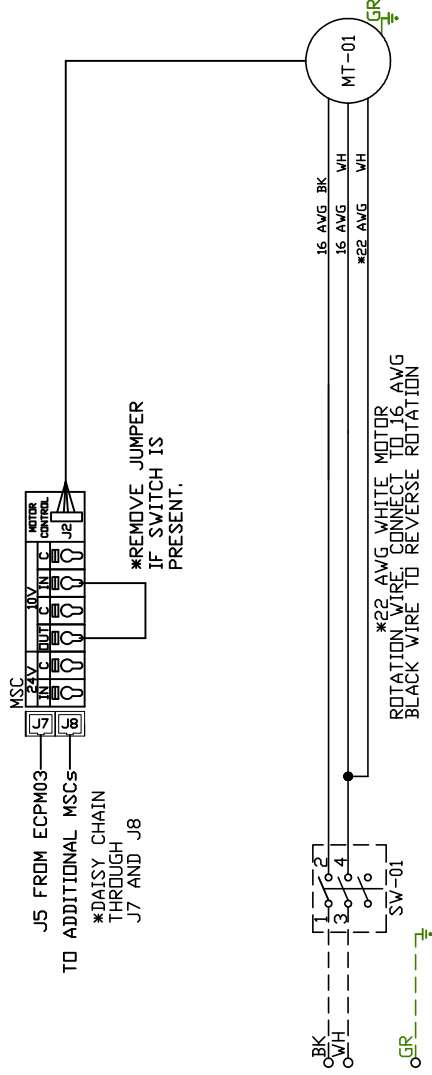

1
2
3
4
5
6
7
8
9
10
11
12
13
14
15
16
17
18
19
20
21
22
23

Installed Options

Component Identification Location

Label Description Location

MT-01 Fan Motor [3]

MSC Motor Speed Controller [1]
SW-01 Main disconnect switch [3]

EXHAUST MOTOR INFO
1HP-115V-IP-11.6FLA

ELECTRICAL INFORMATION
MOTOR/CTRL MCA: 14.5A
MOTOR/CTRL MOP: 25A

NOTES
--- DENOTES FIELD WIRING
--- DENOTES INTERNAL WIRING

WIRE COLOR

- BK - BLACK
- BL - BLUE
- BR - BROWN
- DR - ORANGE
- RD - RED
- WH - WHITE
- YW - YELLOW
- GR - GREEN
- GY - GRAY
- PR - PURPLE
- PK - PINK

ELECTRICAL PACKAGE - JOB#5910325

NO	TAG	PACKAGE #	LOCATION	SWITCHES		OPTION	FANS CONTROLLED					
				LOCATION	QUANTITY		FAN TAG	TYPE	φ	HP	VOLT	FLA
1	10'Nonheat	SC-111110MA	UTILITY CABINET RIGHT	FACE MOUNT LEFT	1 LIGHT	SMART CONTROLS THERMOSTATIC CONTROL W/ RELAY ON/OFF WITH SUPPLY	10' Nonheated	EXHAUST	1	1.000	115	11.6
				SIDE OF HOOD			10' Nonheated	SUPPLY	1	1.000	115	11.6
				HOOD # 1	1 FAN							



FloAire

JOB 10' Nonheated UC Right** Hood Stock	
LOCATION ,	
DATE 3/20/2023	JOB # 5910325
DWG # 13	DRAWN BY courtneyh
REV.	SCALE 3/8" = 1'-0"

JOB NO
5910325

MODEL NUMBER
SC-11110MA

JOB NAME
10' Nonheated UC Right Hood...

DRAWN BY
INSTALL

DATE
3/20/2023

SCHEMATIC TYPE
DWG NO
ECP #1-1

DESCRIPTION OF OPERATION:

120V 1 Phase w/ control for 1 Exhaust Fan, 1 Supply Fan, Exhaust on In Fire, Lights out in Fire, Relay On/Off with Supply Fan, Fans On/Off Thermostatically Controlled. Room temperature sensor shipped loose for field installation.

BREAKER PANEL TO PRIMARY CONTROL PANEL

Responsibility: Electrician

BREAKER SIZE SHOWN IS THE MAXIMUM ALLOWED

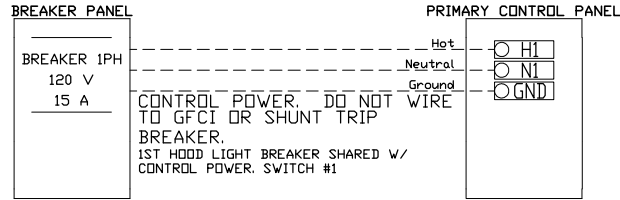

BREAKER PANEL TO FANS

Responsibility: Electrician

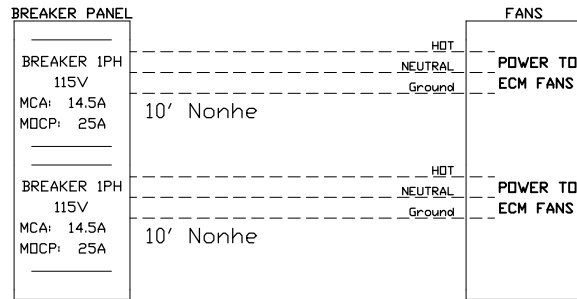

CONTROL PANEL TO ACCESSORY ITEMS

Responsibility: Electrician

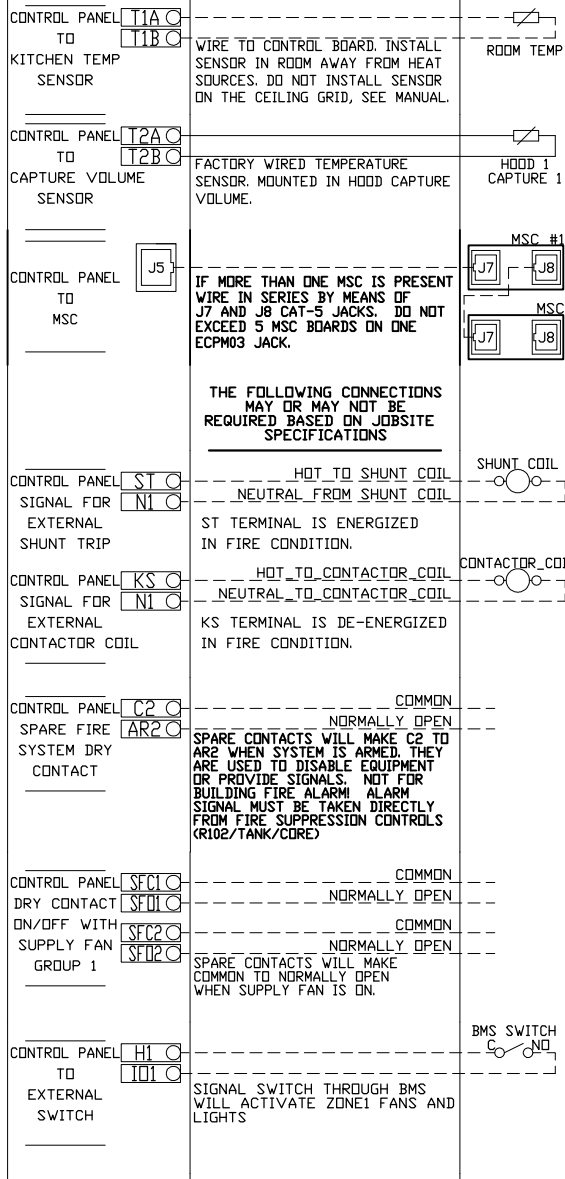
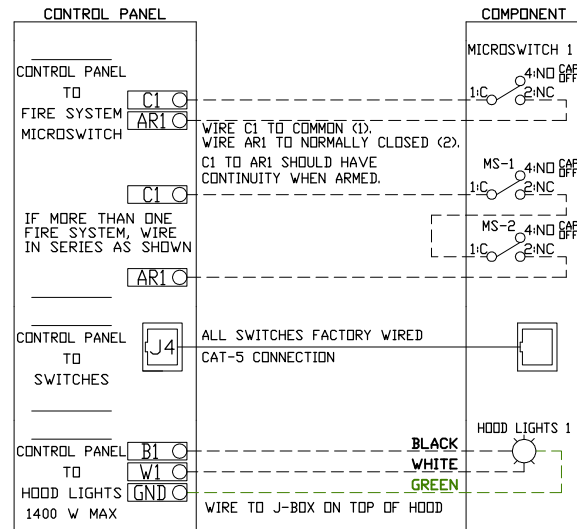

THE FOLLOWING CONNECTIONS MAY OR MAY NOT BE REQUIRED BASED ON JOBSITE SPECIFICATIONS

HOT TO SHUNT COIL
NEUTRAL FROM SHUNT COIL
ST TERMINAL IS ENERGIZED IN FIRE CONDITION.

HOT TO CONTACTOR COIL
NEUTRAL TO CONTACTOR COIL
KS TERMINAL IS DE-ENERGIZED IN FIRE CONDITION.

COMMON NORMALLY OPEN
SPARE CONTACTS WILL MAKE C2 TO AR2 WHEN SYSTEM IS ARMED. THEY ARE USED TO DISABLE EQUIPMENT OR PROVIDE SIGNALS. NOT FOR BUILDING FIRE ALARM! ALARM SIGNAL MUST BE TAKEN DIRECTLY FROM FIRE SUPPRESSION CONTROLS (R102/TANK/CDRE)

COMMON NORMALLY OPEN
COMMON NORMALLY OPEN
SPARE CONTACTS WILL MAKE COMMON TO NORMALLY OPEN WHEN SUPPLY FAN IS ON.

H1 I01
SIGNAL SWITCH THROUGH BMS WILL ACTIVATE ZONE1 FANS AND LIGHTS

UNLESS SPECIFIED OTHERWISE, ALL FACTORY AC WIRING 16 AWG. ALL FACTORY DC WIRING 18 AWG.

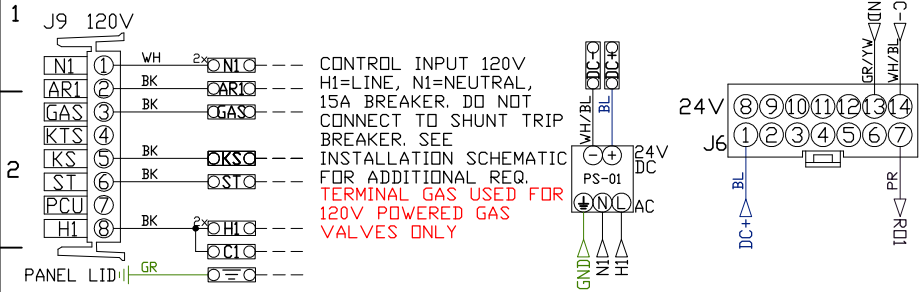

NOTE: All items on ECPM03 J3 line to be daisy chained from one component to the next, with EOL120A at end of line. Place PN: EOL120A in empty RJ45 port.
ECPM03/DAISY CHAIN

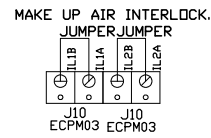
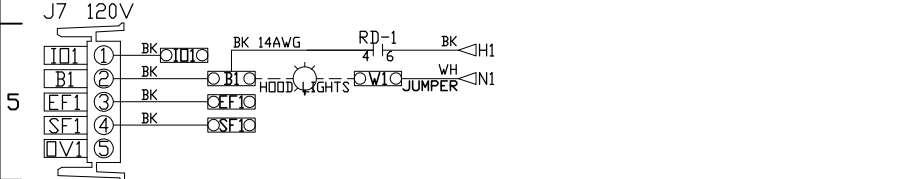
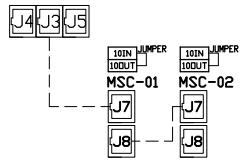

MOTOR POWER CIRCUIT

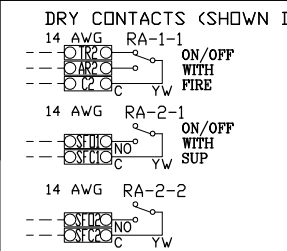
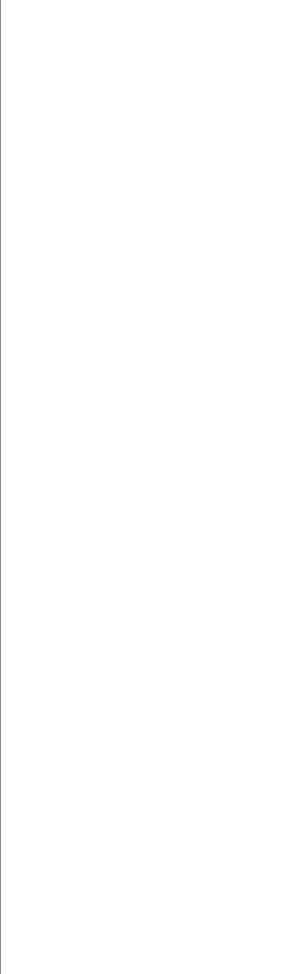

FACTORY WIRING SCHEMATIC CIRCUIT BOARDS

DCV	Rev. 2.14.00	RD-x	24 VDC RELAY
HMI	Rev. 2.14.00	NO	4 3
		NC	2 1
		COIL	8 7
		COM	6 5

COMPONENT LIST

LABEL	DESCRIPTION
ST-X	Starter varies
DL-X	Overload varies
C-X	Contactors varies
PS-1	Power Sup. 24VDC MDPI8-24A-1C
RA-x	120V Relay DPDT 34.110.0184.0
RD-x	24VDC Light Relay 34.110.0188.0
TS-x	Duct Thermostat A/CP-PD-T4'-EXPL

LEGEND

---	FIELD WIRING
---	FACTORY WIRING
BK-	BLACK
BL-	BLUE
BR-	BROWN
DR-	ORANGE
WH-	WHITE
YW-	YELLOW
GR-	GREEN
GY-	GREY
BL/RD-	BL/RD STRIPE
RD/GN-	RD/GN STRIPE
WH/BL-	WH/BL STRIPE

DRY CONTACTS (SHOWN DE-ENERGIZED)

14 AWG RA-1-1
ON/OFF WITH FIRE

14 AWG RA-2-1
ON/OFF WITH SUP

14 AWG RA-2-2
ON/OFF WITH SUP

JOB NAME
10' Nonheated UC...
DRAWING TITLE
SC-111110MA
DESCRIPTION OF OPERATION
120V 1 Phase w/ control for 1 Exhaust Fan, 1 Supply Fan, Exhaust on in Fire, Lights out in Fire, Relay On/Off with Supply Fan, Fans On/Off Thermostatically Controlled. Room temperature sensor shipped loose for field installation.

JOB NO	DRAWN BY
5910325	
TYPE	DATE
FACTORY	3/20/2023
DWG NO	ECP #1-2