



## One Piece REDUCE BORE THREADED / FIRE SAFE

### Omni Series

#### Models:

T12-SS

T12-CS

#### Size Range:

1/2" ~ 2"

#### Temperature Range:

-20° ~ 450°F

#### Maximum Pressures:

2000 MAWP/WOG

175 SWP

**Available in**  
**316SS or WCB**

T12 Series  
STANDARD PRODUCT NUMBER  
T12-SS-RGG-L  
T12-CS-RGG-L



## DESIGN FEATURES

- **Economical** One Piece Design compact unibody delivers outstanding high pressure service in a cost effective package.
- **Replaceable** seats and seals
- All bodies are marked with a foundry heat number for full traceability.
- **Adjustable** stem packing
- one piece body minimizes potential leak paths.
- **Fire Safe** Certified to API607 4<sup>th</sup> Edition
- **Seats** - 25% carbon-PTFE
- **Graphite packing**
- **Anti-static devices** are standard, grounding ball & stem to body.
- **Safety locking handle** lever & oval types
- **Blow-out proof stem**
- **Actuator mounting pad**

**Designed for Economical High Pressure Applications**

[www.flotite.com](http://www.flotite.com)

**Design & Technical Data**

**Models:  
Carbon Steel - T12CS  
Stainless Steel - T12SS**

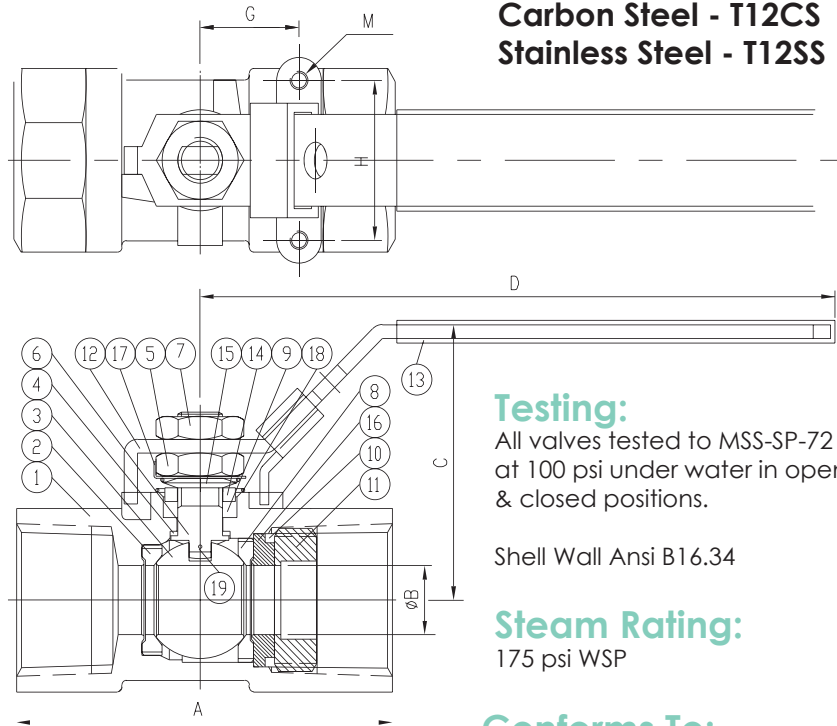

**Testing:**  
All valves tested to MSS-SP-72 at 100 psi under water in open & closed positions.

Shell Wall Ansi B16.34

**Steam Rating:**  
175 psi WSP

**Conforms To:**

- API STANDARD 6D
- ANSI B1.20.1 Threaded End NPT
- Fire Safe Testing API607-4
- NACE MR-01-75

**Dimensions & Technical Data**

SIZE	A	B	C	D	G	H	M	Cv	Torque In-Lb	Weight Lbs
1/4"	2.64	0.35	1.73	4.37	0.50	1.12	#10-24UNC	2	60	0.7
3/8"	2.64	0.35	1.73	4.37	0.50	1.12	#10-24UNC	2.5	60	0.68
1/2"	2.64	0.35	1.73	4.37	0.50	1.12	#10-24UNC	5	76	0.6
3/4"	2.80	0.49	1.89	4.37	0.50	1.12	#10-24UNC	10	102	0.82
1"	3.31	0.59	2.36	5.55	0.87	1.37	#10-24UNC	15	182	1.31
1-1/4"	3.70	0.79	2.56	5.55	0.87	1.37	#10-24UNC	25	245	2.01
1-1/2"	3.94	0.98	2.80	6.34	0.93	1.50	1/4-20UNC	40	356	2.80
2"	4.65	1.26	3.03	6.34	0.93	1.50	1/4-20UNC	60	560	4.21

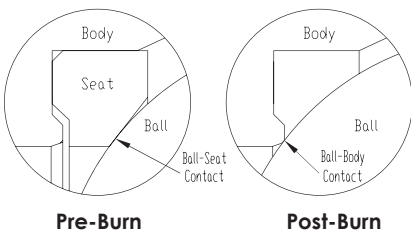

**FIRE SAFE.** Flo-Tite's Model T12 valves are supplied as standard with graphite stem packing and body seal. Valves are certified fire safe. In the event of a fire, after heat destroys the primary resilient seat, the ball makes contact with the secondary metal seat, forming a secure seal. The graphite body seal prevents external leakage. The graphite live-loaded stem packing prevents stem leakage. All valves have anti-static devices, grounding ball and stem to the body as standard.

**BILL OF MATERIALS:**

No.	Parts	T12-SS	T12-CS	Qty
1	Body	A351 CF8M	A216 WCB	1
2	Seat #	25% Carbon PTFE	25% Carbon PTFE	1
3	Ball	A351 CF8M	A351 CF8	1
4	Thrust Washer #	PTFE	PTFE	1
5	Packing Nut	SS304	SS304	1
6	Stem	A276 316	A276 304	1
7	Handle Nut	SS304	Zinc Plated C.S.	1
8	Seat #	25% Carbon PTFE	25% Carbon PTFE	1
9	Packing #	Graphite	Graphite	1
10	Body Gasket #	Graphite	Graphite	1
11	Retainer Nut	A351 CF8M	A216 WCB	1
12	Handle	SS304	Zinc Plated C. S.	1
13	Handle Cover	PVC	PVC	1
14	Packing Follower	SS304	SS304	1
15	Belleville Washers	SS301	SS301	2
16	Seat Retainer	A351 CF8M	A216 WCB	1
17	Lock Washer	SS304	SS304	1
18	Anti-Static Springs	SS301	SS301	2
19	Anti-Static Device	SS316	SS304	1

# Parts included in the repair kits

**ATTENTION**  
MAWP/WOG is a do not exceed pressure at normal ambient NPT & Weld End Models

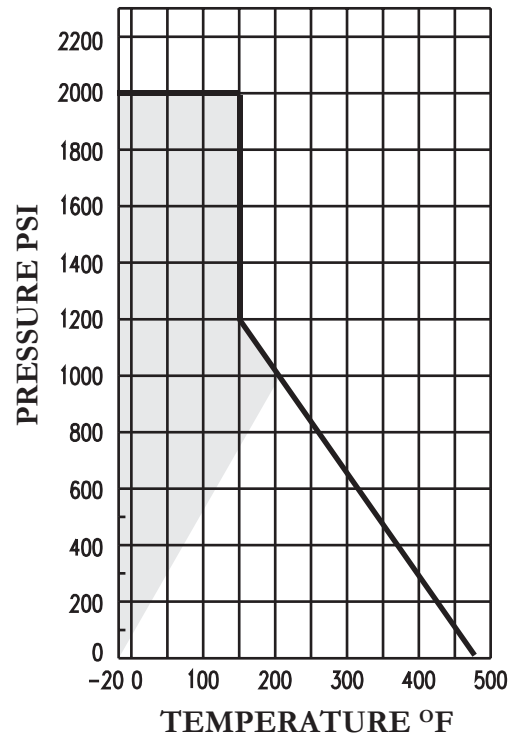

Flo-Tite, Inc.  
4815 West 5th St.  
Lumberton, NC 28358

P. O. Box 1293  
Lumberton, NC 28359  
Website: www.flotite.com

Tel: (910) 738-8904  
Fax: (910) 738-9112  
E-mail: flotite@flotite.com