



Two Piece Reduced Bore Flanged End Ball Valve



EZ Series

Easy Maintenance Design

Features a Two Piece Bolted Body

EZ Series

STANDARD PRODUCT NUMBER

- RF15-SS-FFG-L (150# SS Standard FFG)
- RF15-SS-FGG-L (150# SS Fire-Safe FGG)
- RF15-CS-FFG-L (150# CS Standard FFG)
- RF15-CS-FGG-L (150# CS Fire-Safe FGG)
- RF30-SS-FFG-L (300# SS Standard FFG)
- RF30-SS-FGG-L (300# SS Fire-Safe FGG)
- RF30-CS-FFG-L (300# CS Standard FFG)
- RF30-CS-FGG-L (300# CS Fire-Safe FGG)

Models:

- RF15 - Short Pattern
- RF150 - Long Pattern
- V-RF15 & V-RF150
- Control Ball Valve
- Size Range 3" - 14"
- ANSI Class 150

Models:

- RF30 - Short Pattern
- V-RF30
- Control Ball Valve
- Size Range 3" - 6"
- ANSI Class 300

ANSI Reduced Bore
Short Take-out



10" Model RF15 - Short

ANSI Full Bore Take-out



10" Model RF150 - Long

Versatile Design Offers:

- Ease of Seat Replacement or Seat Change-Outs
- Ease of Maintenance
- Custom V-Port Control Options
- Improved Flow Control
- Lighter Weight than Full Port
- Lower Cost than Full Port
- Lower Operating Torques
- Fire Safe Design
- Comply with API & ANSI Standards

Simplicity & Performance, an ideal choice for applications that require easy to repair, reduced port flanged-end ball valves.

RF15/RF30

DESIGN FEATURES AND STANDARDS

Standards and Specifications

Valves mentioned in this bulletin are available to conform to the following industry standards and specifications:

All valves are manufactured to ISO 9001 quality standards

WW-V-35C	Federal specification: valve, ball
ANSI/ASME B16.10	Face-to-face / end-to-end dimensions of ferrous valves
ANSI/ASME B16.5	Steel pipe flanges and flange fittings
ANSI/ASME B16.34	Steel valves - flanged and butt welded end
ANSI/ASME B31.1	Power piping
ANSI/ASME B31.3	Chemical plant & petroleum refinery piping
ANSI/FCI70-2-1976	For control valve leakage
BS 6755, Part 2	Testing of valves-specification for fire type testing
ISA 5752:1982	Metal valves for use in flange piping systems
ISA 75.02	Valve sizing coefficient Cv, piping geometry factor Fp & pressure drop limitation XT
ISA S75.19	Hydrostatic testing of control valves
ISO 5211	Dimensions for attachment of actuators/ gear boxes to valves (ISO mounting)
MSS-SP-25	Standard marking systems for valves
MSS-SP-55	Quality standards for steel casting

MSS-SP-6	Standard finishes for contact faces of pipe flanges and connecting-end flanges of valve and fittings
MSS-SP-44	Steel pipe line flanges
MSS-SP-61	Pressure testing of steel valves
MSS-SP-72	Ball valves with flanged or butt welded ends for general service
MSS-SP-96	Terminology for valves and fittings
NACE MR0175	Sulfide stress cracking resistant materials for oilfield equipment

Optional Standard & Specifications

API 608	Metal ball valves - Flanged, Threaded, and Welding End
API 6D	Specifications for pipeline valves
API 598	Valve inspection and testing
MSS-SP-53	Quality standard for steel casting and forging for valves, flanges and fittings and other piping component - magnetic particle examination method
MSS-SP-93	Quality standard for steel casting and forging for valves, flanges, fittings or other piping components - liquid penetrant examination method
ISO 15848-1	Industrial valves - measurements, test & qualification procedures for fugitive emissions

Flo-Tite's Flanged series valves with graphite stem packing meet the highest fire safety standards under extreme conditions. In the event of a fire, after heat destroys the primary resilient seat, the ball makes contact with the secondary metal seat, forming a secure seal. The body seal, composed of stainless steel and graphite wound into a spiral, prevents external leakage. The graphite stem rings prevent stem leakage.

Fire Safe: API607-4 & 5 Certified

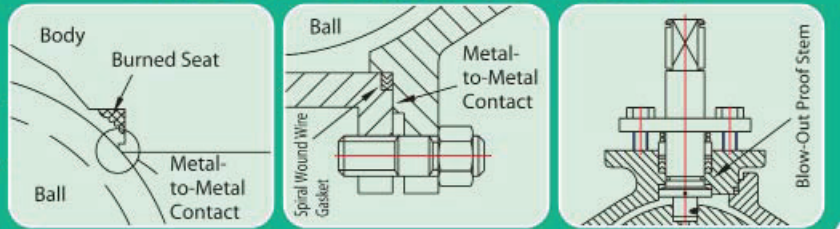

Tamper-Proof Locking Device Standard

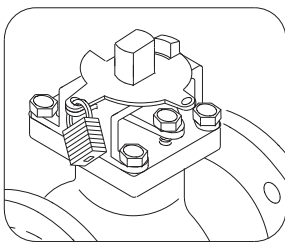

Valve topworks incorporate a tamper-proof locking device, which locks in open or closed positions. When the valve stop housing is removed, four bolts remain to mount actuator bracket. Size: 6" - 14"

Pressure Relieving & Equalizing Seat Design

Specially Designed Seats allow equalization of pressure in the ball cavity which reduces operating torque and increases seat life.

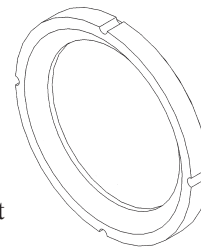

Ball Design Added Safety Feature

All balls are provided with a 1/8" hole drilled into the stem slot of each ball to prevent excessive pressure build up in the cavity from trapped liquid when the valve is in the open position.

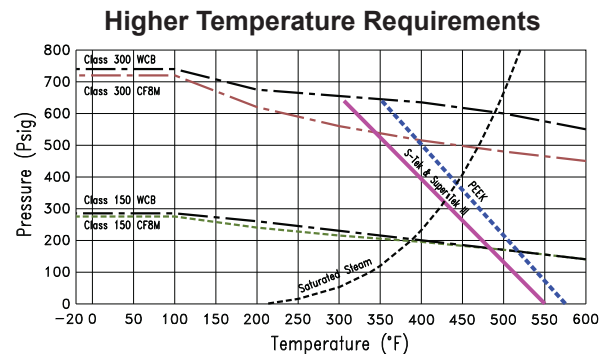
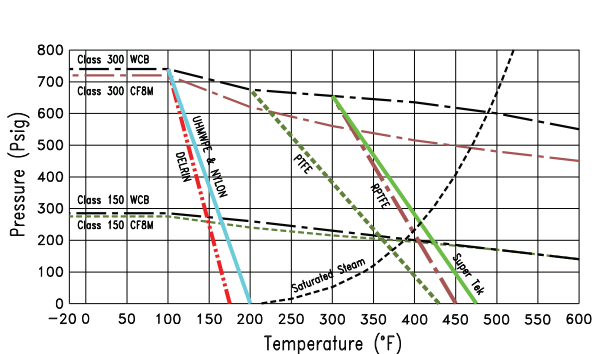

Pressure Temperature Rating

DIMENSIONS AND TECHNICAL DATA

No.	Name	Stainless Steel	Carbon Steel	Qty
1	Body	ASTM A351 CF8M	ASTM A216 WCB	1
2	Cap	ASTM A351 CF8M	ASTM A216 WCB	1
3	Ball	SS316	SS316 / SS304	1
4	Seats	# TFM	TFM	2
5	Stem	SS316 / 17-4PH	SS316 / 17-4PH	1
6	Gasket	# RPTFE / Graphite	RPTFE / Graphite	1
7	Thrust Washer	# 25% Carbon + TFM	25% Carbon + TFM	1
8	Stem Packing	# TFM / Graphite	TFM / Graphite	1
9	Packing Protector	# 50% PTFE + SS316	50% PTFE + SS316	1
10	O-Ring	# Viton	Viton	1
11	Anti-Static Devices	SS304	SS304	2
12	Body Studs	ASTM A193 B8	ASTM A193 B7	set
13	Body Nuts	ASTM A194 Gr. 8	ASTM A194 2H	set
14	Packing Follower	SS304	SS304	1
15	Packing Gland	SS304 / 17-4PH	SS304 / 17-4PH	1
16	Gland Bolts	SS304	Steel	2
17	Travel Stop	SS304	Steel	1
18	Junction Head	Ductile Iron	Ductile Iron	1
19	Pipe Grip	Carbon Steel	Carbon Steel	1
20	Housing Bolts	SS304	SS304	4
21	Stop Housing	SS304	SS304	1
22	Snap Ring	Plated Steel	Plated Steel	1
23	Seat O-Rings	# Viton	Viton	2
24	Belleville Washers	SS301	SS301	2

Model:
RF15 Series 3" - 14"
RF150 Series 3" - 12"
Exploded View

Consult Factory
for Other Sizes

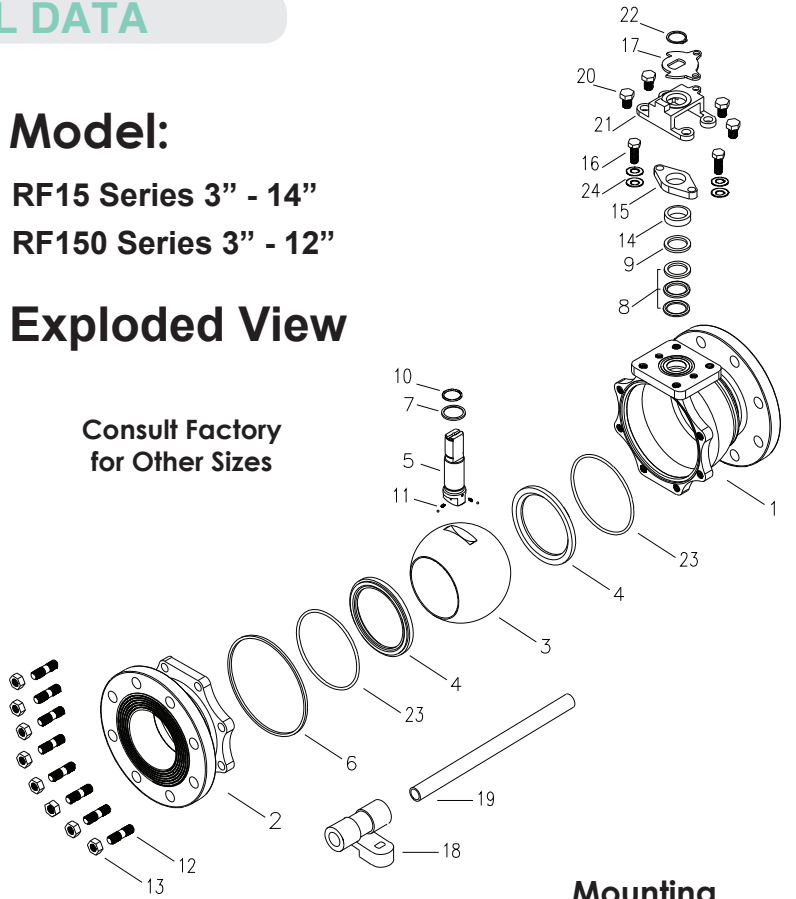

Parts included in repair kits

For 6" size, packing gland is live-loaded, and handle is one piece design;
For size 12" & 14", packing gland serves as stop housing.
Sizes 1 1/2" through 4" are available in our standard one piece body design
SF150 Series, consult factory.

Mounting Dimensions

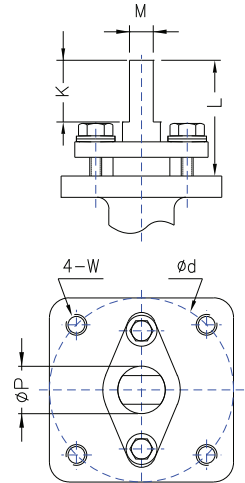

Note:
Verify Mounting Dimensions
prior to making hardware.

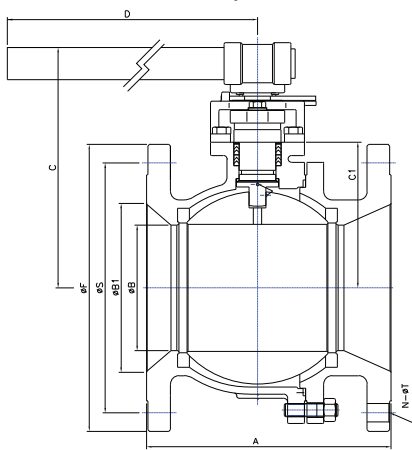

RF15 / Short

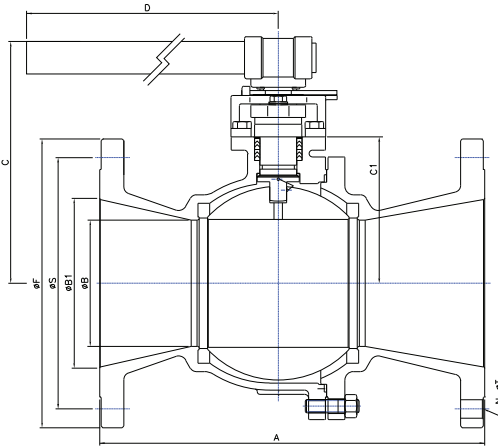

RF150 / Long

(Reduced Port Valve with Full Port Face to Face)

Dimensions and Weights

Size	RF15		RF150		B1	C	C1	D	d	F	K	L	M	N	P	S	T	W	Cv	Torque in-lb	Weight Lbs	
	A	B	A	B																	RF15	RF150
3"	8.0	2.56	8.0	2.56	3.00	6.63	3.35	15.4	4.02	7.5	1.75	3.07	0.669	4	1.10	6.00	0.75	1/2-13unc	340	620	C/F	C/F
4"	9.0	2.99	9.0	2.56	3.94	6.92	3.62	15.4	4.02	9.0	1.75	3.07	0.669	8	1.10	7.50	0.75	1/2-13unc	800	800	C/F	C/F
6"	10.5	4.02	15.5	4.02	5.98	7.68	4.47	15.4	4.02	11.0	1.75	3.07	0.669	8	1.10	9.50	0.88	1/2-13unc	1090	1700	82.5	C/F
8"	11.5	5.98	18.0	5.98	7.87	11.31	7.17	25.4	4.92	13.5	1.65	3.58	1.024	12	1.71	11.75	0.88	1/2-13unc	2300	4600	186	C/F
10"	13.0	7.87	21.0	7.87	9.84	12.10	7.60	25.4	4.92	16.0	1.65	3.58	1.024	12	1.71	14.25	1.00	1/2-13unc	4000	9900	279.5	310
12"	14.0	9.53	24.0	9.84	11.81	13.22	9.88	43.1	5.51	19.0	2.13	3.86	1.378	12	1.97	17.00	1.00	5/8-11unc	7700	17000	426.5	C/F
14"	15.0	9.84	-	-	14.00	13.22	9.88	43.1	5.51	21.0	2.13	3.86	1.378	12	1.97	18.75	1.12	5/8-11unc	11550	23000	C/F	C/F

DIMENSIONS AND TECHNICAL DATA

No.	Name	Stainless Steel	Carbon Steel	Qty
1	Body	ASTM A351 CF8M	ASTM A216 WCB	1
2	Cap	ASTM A351 CF8M	ASTM A216 WCB	1
3	Ball	SS316	SS316 / SS304	1
4	Seats	# TFM	TFM	2
5	Stem	SS316 / 17-4PH	SS316 / 17-4PH	1
6	Gasket	# RPTFE / Graphite	RPTFE / Graphite	1
7	Thrust Washer	# 25% Carbon + TFM	25% Carbon + TFM	1
8	Stem Packing	# TFM / Graphite	TFM / Graphite	1
9	Packing Protector	# 50% PTFE + SS316	50% PTFE + SS316	1
10	O-Ring	# Viton	Viton	1
11	Anti-Static Devices	SS304	SS304	2
12	Body Studs	ASTM A193 B8	ASTM A193 B7	set
13	Body Nuts	ASTM A194 Gr. 8	ASTM A194 2H	set
14	Packing Follower	SS304	SS304	1
15	Packing Gland	SS304 / 17-4PH	SS304 / 17-4PH	1
16	Gland Bolts	SS304	Steel	2
17	Travel Stop	SS304	Steel	1
18	Set Screw	Steel	Steel	1
19	Handle	Ductile Iron	Ductile Iron	1
20	Housing Bolts	SS304	SS304	4
21	Stop Housing	SS304	SS304	1
22	Snap Ring	Plated Steel	Plated Steel	1
23	Seat O-Rings	# Viton	Viton	2
24	Belleville Washers	SS301	SS301	2

Parts included in repair kits

For 6" size, packing gland is live-loaded, and handle is one piece design;
For size 12" & 14", packing gland serves as stop housing.
Sizes 1 1/2" through 2" & 8" through 12" are available in our standard one piece body design SF300 series, consult factory.

Model: RF30 Series 3" - 6"

Exploded View

Consult Factory
for Other Sizes

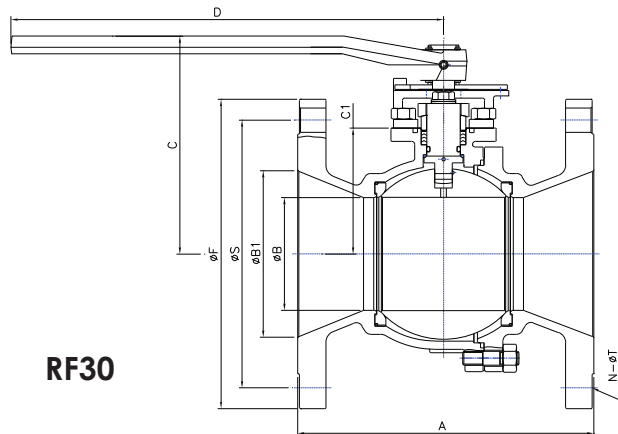
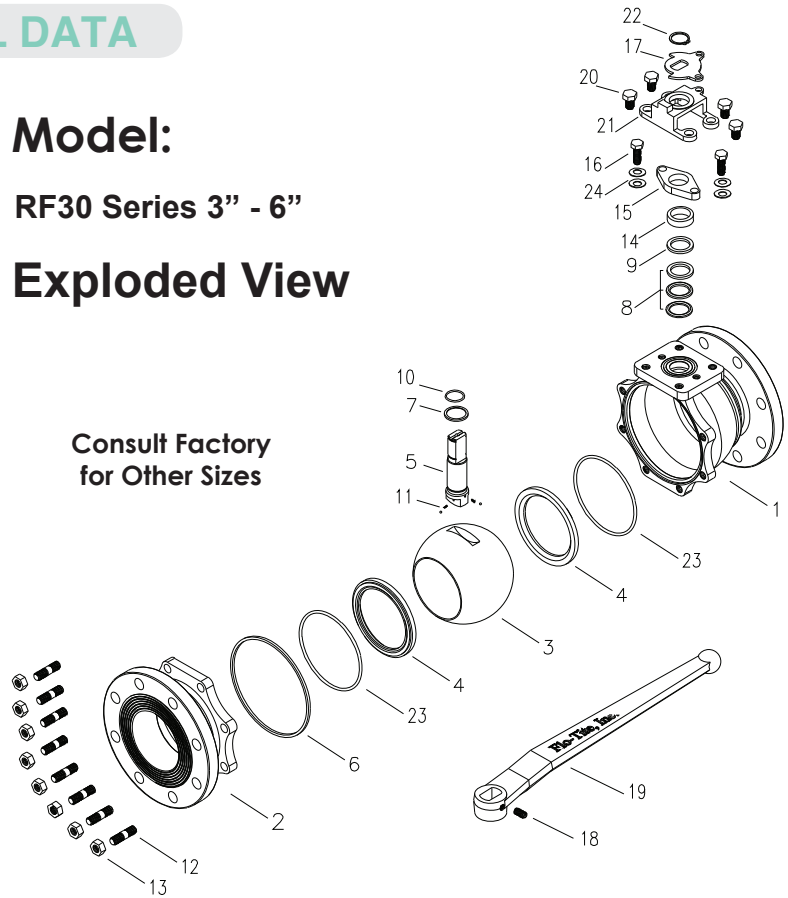

RF30

Mounting Dimensions

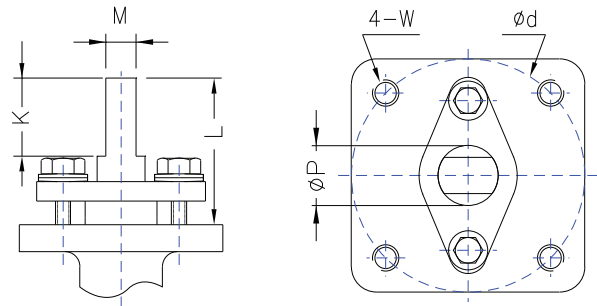

Note:
Verify Mounting Dimensions prior to making hardware.

Dimensions and Weights

Size	A	B	B1	C	C1	D	d	F	K	L	M	N	P	S	T	W	Cv	Torque in-lb	Weight Lbs	ISO
3"	11.14	2.24	3.00	6.65	3.39	15.4	4.02	8.28	1.75	3.07	0.669	8	1.10	6.62	0.87	1/2-13unc	340	700	C/F	F10
4"	12.0	3.15	4.00	6.93	3.62	15.4	4.02	10.0	1.75	3.07	0.669	8	1.10	7.87	0.87	1/2-13unc	800	900	C/F	F10
6"	15.87	3.94	5.98	7.68	4.47	15.4	4.02	12.5	1.75	3.07	0.669	12	1.10	10.63	0.87	1/2-13unc	1090	1874	C/F	F10
8"	16.5	5.91	7.87	11.91	6.85	25.6	4.92	15.0	1.65	3.58	1.024	12	1.71	12.99	0.98	1/2-13unc	1900	3470	C/F	F12



Flo-Tite, Inc.
4815 West 5th St.
Lumberton, NC 28358

P. O. Box 1293
Lumberton, NC 28359
Website: www.flotite.com

Tel: (910) 738-8904
Fax: (910) 738-9112
E-mail: flotite@flotite.com

Due to continuous development & improvement of our product range, we reserve the right to alter the dimensions and technical data included in this brochure.