



FLAME SAFEGUARD CONTROLS



Primeline Products

Distributed by:



888.858.3647 | relevantsolutions.com

For over 70 years, Fireeye has manufactured quality combustion control products for the commercial and industrial markets. With more than a million installations throughout the world, we are proud of our global reputation and worldwide market position. Dedicated to a constant process of innovation and service, we consistently provide safe and reliable products to our customers.

©Fireye, Inc. 2016

The names FIREYE, MicroM, SIGNATURE SCANNER, FIRETRON and FLAME-MONITOR are registered trademarks of Fireye, Inc.

Products in this catalog are not necessarily shown to scale.

For additional information visit our web site at www.fireye.com

NOTICE: When Fireye products are combined with equipment manufactured by others and/or integrated into systems designed or manufactured by others, the Fireye warranty, as stated in its General Terms and Conditions of Sale, pertain only to the Fireye products and not to any other equipment or to the combined system or its overall parts.



IMPORTANT NOTICE

Periodically, Fireeye receives inquiries from the field concerning the use of rebuilt controls. In years past, Fireeye and other manufacturers of flame safety devices did rebuild controls.

These rebuilt controls were certified by a “nationally recognized testing agency” (UL) and subject to different standards than new equipment. Essentially, all components were replaced with the exact components that were used in a new control. Only the housings and lenses (if applicable) were reused. Fireeye no longer rebuilds controls (as of 1989), nor have we authorized any other company to rebuild for us.

Currently, there are several other companies selling “rebuilt” or “reconditioned controls. None of these companies has an approval from any nationally recognized testing agency. What this means is the following.

1. Fireeye assumes no liability for any incident resulting from the use of a rebuilt control.
2. Your insurance coverage should be reviewed if you use rebuilt controls.
3. The use of safety controls rebuilt by any party other than the original manufacturer is in violation of ASME, CSD-1 standard.
4. Use of rebuilt controls is in violation of National Fire Protection Agency Association.

For over seventy years, Fireeye has been a leader in promoting flame safety. We are very committed to adhering to standards established by testing agencies, fire codes and insurance requirements as well as developing new scanner technology.

PART NUMBER INDEX

PART NUMBER	PAGE	PART NUMBER	PAGE	PART NUMBER	PAGE
4-263-1	45	59-509-20	19	65UV5-1004E	37
4-314-1	45	59-509-25	19	65UV5-1004ECEX	37
10-88	45	59-562-2	25	69ND1-1000K4	40, 44
14-64	8, 26	59-565	25	69ND1-1000K6	40, 44
23-176	35	59-565-6	25	69ND1-1000K8	40, 44
23-183	35	59-565-40	25	70D10	29
35-69	45	60-302	45	70D20	29
35-127-1	45	60-801	45	70D21	29
35-127-3	45	60-1199-1	46	70D30	29
35-381-2	25	60-1199-2	46	70D40	29
38-96	45	60-1257	46	70D41	29
38-97	45	60-1290	46	71D60	29
45UV3-1050	44	60-1386-2	8, 26, 29	71D61	29
45UV5-1005	44	60-1466-2	8, 26, 29	71D70	29
45UV5-1006	44	60-1664-3	46	71D80	29
45UV5-1007	44	60-1664-4	46	71D81	29
45UV5-1007CEX	44	60-1950	13, 28	71D90	29
45UV5-1008	47	60-2539-12	39	72D1R1	29
45UV5-1009	44	60-2539-24	39	72D1R1T	29
45UV5-1009CEX	44	60-2539-36	39	72D1R3	29
45UV5-1009EX	44	60-2726	39	72D1R3T	29
45UV5-1105	44	60-2810-1	15	72DRT1	29
46-38	45	60-2812-1	15	72DRT1T	29
46-56	45	60-2814-1	15	72DUV1	29
48-1805	8, 26, 45	60-2850-1	17	72DUVS1T	29
48-1836	8, 26, 45	60-2852-1	17	72DUVS4	29
48PT2-1003	44	60-2854-1	17	82-95	46
48PT2-1007	44	60-2872-1	18	129-145-1	9
48PT2-9003	44	60-2874-1	18	129-145-2	9
48PT2-9007	44	60-2926	25	129-145-3	9
48PT2-9007W	44	61-2914-1	46	129-168-1	37
48PT2-CEX	44	61-436	46	129-168-2	37
57AV7-1000	35	61-2914-1	50	129-172	39
57YB4-5000	15	61-3060	33, 35	129-178-4	15, 17
59-504-010	40	61-3263-1	46	129-178-8	15, 17
59-509-10	19, 40	61-5042	33, 35	129-189	25
59-509-15	19	61-5745-3	15, 17, 46	129-190	25
		65UV5-1004	37	129-192	25

PART NUMBER	PAGE
BLD500	15, 17
BLL510	15, 17
BLPS-15	25
BLPS-25	25
BLPS-30	25
BLPS-200	25
BLPS-300	25
BLV512	15, 17
E1R1	12, 27
E1R2	12
E1R3	12, 27
E100	8
E110	8
E120	8
E210	26
E211	26
E300	13
E320	28
E350-3	13, 28
E350-6	13, 28
EB700	8
EB720	26
EB721	26
EC485	13, 18, 28
EC600	8
EDC1	12
EDC2	12
ED510	9, 26
ED512-2	13, 18, 19, 28
ED512-4	19
ED512-8	19
ED580-1	9
ED580-2	9
ED580-4	9, 18
ED580-8	9, 18
ED610	9, 19
EP100F	10
EP100S	10
EP113D	27

PART NUMBER	PAGE
EP113E	27
EP113ES	27
EP113F	27
EP113NL	27
EP113NR	27
EP113SW	27
EP160	10
EP161	10
EP163	10
EP165	10
EP166	10
EP170	10
EP174	10
EP177	10
EP178	10
EP200F	10
EP200S	10
EP260	10
EP265	10
EP270	10
EP300F	10
EP300S	10
EP378	10
EP380	10
EP381	10
EP382	10
EP383	10
EP387	10
EP390	10
EPD160	11
EPD161	11
EPD167	11
EPD170	11
EPD260	11
EPD261	11
EPD270	11
EPD380	11
EPD381	11
EPD382	11

PART NUMBER	PAGE
EPD390	11
ERT1	12, 27
EUV1	12, 27
EUVS4	12, 27
FX04	25
FX04-1	25
FX20	25
FX20-1	25
FX50	25
FX50-1	25
IT1000	15, 17, 19
MART1	35
MART1T	35
MART3	35
MAUV1	35
MAUV1T	35
MAUV3	35
MB-600PF	38, 39
MB-600S	38
MB-604E	38
MB-608E	38
MB-632S	38
MB-685S	38
MBPF-100S	39
MBPF-200S	39
MBPF-202S	39
MC120	35
MC120E	35
MC120P	35
MC120R	35
MC120RE	35
MC230	35
MC230R	35
MEC120	31
MEC120C	31
MEC120D	31
MEC120R	31
MEC120RC	31
MEC120RD	31

PART NUMBER	PAGE
MEC230	31
MEC230RC	31
MEC320	32
MEC320C	32
MEC320D	32
MEC320R	32
MEC320RC	32
MEC320RD	32
MEC320TS	32
MEC480	32
MECD1	33
MECD4	33
MED1	33
MED2	33
MED3	33
MED4	33
MED5	33
MED6	33
MED7	33
MEDC2	33
MEIR1	32
MEIR4	32
MEP100	32
MEP101	32
MEP102	32
MEP103	32
MEP104	32
MEP105	32
MEP106	32
MEP107	32
MEP108	32
MEP109	32
MEP130	32
MEP141	32
MEP149	32
MEP100P	32
MEP230	32
MEP230H	32
MEP235	32

PART NUMBER	PAGE
MEP236	32
MEP237	33
MEP238	32
MEP290	32
MEP300	33
MEP304	33
MEP397	33
MEP437	32
MEP536	32
MEP537	32
MEP560	32
MEP561	32
MEP562	32
MEP564	32
MEP696	33
MEP697	33
MERT1	33
MERT4	33
MEUV1	33
MEUV4	33
MEUVS1	33
MEUVS4	33
MP100	35
MP100E	35
MP101	35
MP102	35
MP102E	35
MP230	35
MP230H	35
MP560	35
MP561	35
MP562	35
N018032-10	19
N018040-KIT	19
N200233-00	19
N250339-00	19
NXAM	21, 23
NXC04	20, 23
NXC12	20, 23

PART NUMBER	PAGE
NXC20, NXC20A	21, 23
NXC40	21, 23
NXCES02-8	25
NXCES02-16	25
NXCES02-30	25
NXCES02P42, -1	25
NXCESVFD	25
NXD410	25
NXD8MB	21, 23
NXD8VSD	21, 23
NXIATS	21, 23
NX02INT	21, 23
NX02PK4	21, 23
NX02PK6	21, 23
NX02PK8	21, 23
NXTSD104	20
NX600	23
NX610	23
NX1030-1	21
NX1030-2	21
NX1034-1	21
NX1034-2	21
NX1040-1	21
NX1044-1	21
NX6100	20
NX6110	20
PPC4000	25
PPC6000	15, 17, 22
PXMS-15	21, 23
PXMS-200	21, 23
PXMS-300	21, 23
TS350-2	21, 23, 25
TS350-4	21, 23, 25
TS350-8	21, 23, 25
TS752-2	21, 23, 25
TS752-4	21, 23, 25
TS752-8	21, 23, 25
UC485	13, 18
UV1A-1-CEX	44

PART NUMBER	PAGE
UV1A3	44
UV1A6	44
UV1A50	44
UV2	44
UV7A4	40
UV7A4W	40
UV7R4	40
UV7SC	40
UV8A	44
UV90-3	44
UV90-6	44
UV90-9	44
YB110DC	15
YB110FR	15
YB110IR	15
YB110IR2	15
YB110UV	14
YB110UVSC	14
YB230DC	15
YB230FR	15
YB230IR	15
YB230UV	15
YB230UVSC	15
YP100	15, 17
YP102	15, 17
YP113	15, 17
YP118	15, 17
YP138	15, 17
YP200	15
YP202	15
YP300	15
YP302	15
YZ300	18
YZ300P	18
YZ320	18
ZB110IR	17
ZB110IR2	17
ZB110UV	17
ZB110UVSC	17

PART NUMBER	PAGE
ZB230IR	17
ZB230UV	17
ZB230UVSC	17



The Flame-Monitor Series provides the proper burner sequencing, ignition and flame monitoring protection on automatically ignited oil, gas and combination fuel burners. On a safety shutdown, the display module will advise the operator that the control is in "Lockout" and indicate the cause as well as the position in the operating sequence that it occurred.

Interchangeable programmer and flame amplifier modules allow complete versatility in selecting control function. The Flame-Monitor control uses the same wiring base as the Fireye D-Series and C-Series Controls and is directly interchangeable with most models without rewiring.

The Flame-Monitor control can be used with ultraviolet, AUTOCHECK® infrared, photocell, flame rod or self-check ultraviolet flame scanners by choosing the proper amplifier module. Special features include: remote reset, remote display, expanded annunciation of safety lockouts, programmability of safety interlock messages, and remote data communications capability. A 220 volt version of the E110 control is also available without any agency approvals. (P/N E120).

The complete FLAME-MONITOR control consists of:

- E110 Chassis
- ED510 Display Module
- EP Programmer or EPD Programmers
(EPD programmers do not require ED510 display)
- Amplifier
- Scanner
- Wiring Base

Part Number	Description
E100	OBSOLETE - Replace with E110. Display required.
E110	Standard unit consisting of one each EB700, 48-1836, and EC600. Display ordered separately. 120VAC.
E120	Standard unit, consisting of one each EB701, 48-1836, and EC600. 220VAC operation. No agency approvals.
EB700	Replacement chassis only for E110 and E100.
EC600	Replacement dust cover for E110 and E100.
48-1805	Mounting screw for E100, E200, E201, E340
48-1836	Mounting screw for E110, E120, E210, E211
60-1386-2	Wiring Base - Surface Mount
60-1466-2	Wiring Base - Cabinet Mount
14-64	Noise line filter for E100/E110

DIMENSIONS

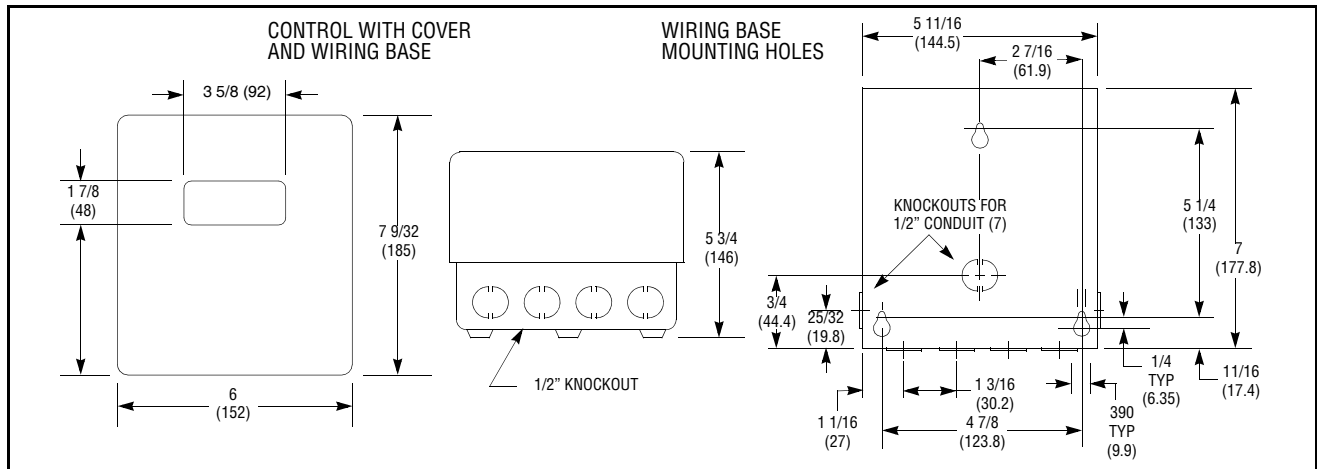

ED510 Display Module

Bulletin ED-5101

The ED510 Display Module is designed to operate with the Flame-Monitor Burner Management Control System using the EP and EPD style programmer modules.¹ The ED510 display is optional for EPD programmers, but is required for the EP style programmers.

The ED510 display module provides the following features and capabilities

- LCD backlit display with two (2) lines of sixteen (16) characters each.
- Continuous display of current burner operating status, including first out annunciation in the event of a lockout condition.
- Three (3) key, tactile dome keypad provides historical information of the burner, last six (6) lockout conditions (with burner cycle and burner hour time stamp), assign messages associated with the operation of the E300 expansion module, and diagnostic messages.
- Design which mounts directly onto the front face of the EP style programmers.
- RJ style connector for connection to the EP and EPD style programmers.¹
- Remote display capability with the EP and EPD style programmers using standard DIN sized opening and remote mounting kit.

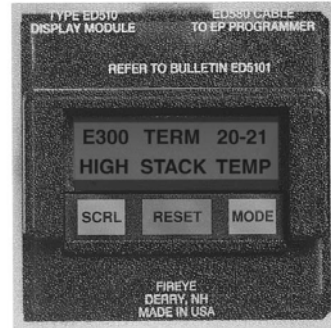

Part Number	Description
ED510	2 line x 16 character LCD display with keypad.
ED580-1	ED510 Display cable with RJ45 connector – 1 1/4 inch
ED580-2	ED510 Remote display cable with RJ45 connector – 2 feet
ED580-4	ED510 Remote display cable with RJ45 connector – 4 feet
ED580-8	ED510 Remote display cable with RJ45 connector – 8 feet
129-145-1	Remote display (ED510) mounting kit with 4 ft. cable.
129-145-2	Remote display (ED510) mounting kit with 8 ft. cable.
129-145-3	Remote display (ED510) mounting kit with 2 ft. cable.
ED610	Adaptor for mounting ED510 display further than 8 feet away from control.

DIMENSIONS TO REMOTE MOUNT ED510 DISPLAY

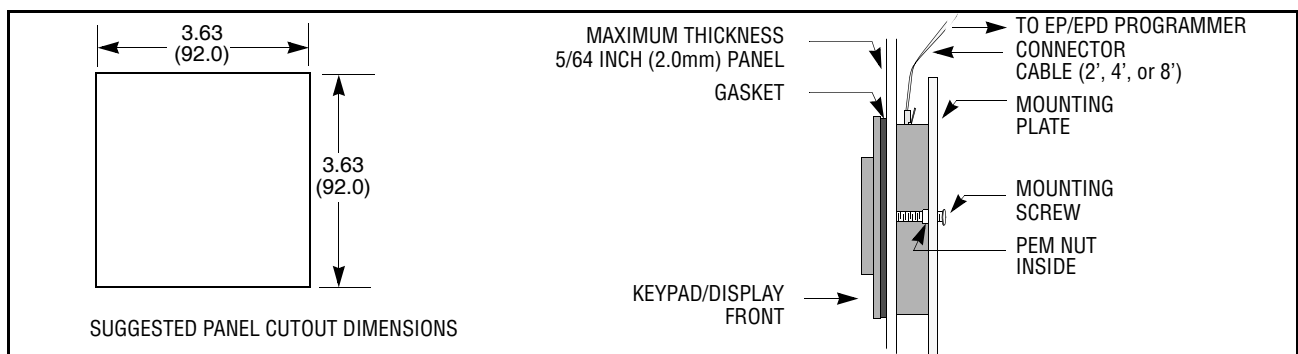

1. The EP programmers must have an Eng. code of 28 or higher, the EPD programmers must have an Eng. code of 02 or higher.

EP PROGRAMMER MODULES

Bulletins EP1601, EP2601, EP3801

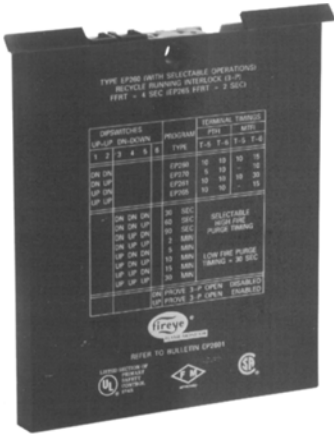

The Fireye EP Programmer Modules are used with the E100 and E110 Flame-Monitor controls. They provide start-up programming, safe-start-check, and flame monitoring supervision. They provide high-fire purge interlock (EP100 series only), low-fire start position and fuel valve end-switch safety checks. A running interlock circuit monitors the limit switches, air flow switches, and fuel pressure switches.

The EP programmers de-energize all fuel valve circuits with 4 seconds (max.) following a flame failure (2 seconds for the EP165, EP166, EP265), or at the end of the pilot-trial-for-ignition period if no flame is detected. A modulator motor circuit is provided (EP100 and EP200 series only). The programmers have a Check-Run switch to stop the control sequence to aid in the set-up and check out of the burner and its associated interlocks. The programmers store the burner cycles, hours, and lockout history.

The EP programmers offer the following selectable functions: purge timing, prove the Running Interlock circuit is open at the start of the cycle, recycle or non-recycle operation (EP300 series only), intermittent or interrupted operation of terminal 6 (EP300 series only). The programmers include an RJ45 connector for the ED510 display module, and two RJ12 connectors for Modbus Communications.

PART NUMBER	DESCRIPTION
EP160	30 Sec. Purge, 10 & 15 Sec. TFI, 4 Sec FFRT, Non-Recycle, Modulation
EP161	30 Sec. Purge, 10 & 30 Sec. TFI, 4 Sec FFRT, Non-Recycle, Modulation
EP163	Selectable Purge (30 sec min.), selectable TFI via ED510 display, Non-Recycle.
EP165	30 Sec. Purge, 10 Sec. TFI, 2 Sec FFRT, Pilot Stabilization, Non-Recycle, Modulation.
EP166	Selectable Purge (30 sec min.), Pilot Stabilization, Non-Recycle, 10 and 15 sec TFI programmer.
EP170	30 Sec. Purge, 5 & 10 Sec. TFI, 4 Sec FFRT, Early Spark Termination, Non-Recycle, Modulation
EP174	Selectable Purge (30 sec min.), 5 and 10 sec. TFI, Non-Recycle, Early Spark Termination. M-D circuit must be proven through the completion of MTFI.
EP177	Early Spark Termination. ED510 to Select Purge (30 sec min.), Prove Air Flow, Prove High Fire, Prove Low Fire, and Post Purge. Early Spark Termination. Infinite Hold on M-D circuit.
EP100F	Selectable Purge, Selectable TFI, 4 Sec FFRT, Non-Recycle, Modulation, French language.
EP100S	Selectable Purge, Selectable TFI, 4 Sec FFRT, Non-Recycle, Modulation, Spanish language.
EP260	30 Sec. Purge, 10 & 15 Sec. TFI, 4 Sec FFRT, Recycle, Modulation
EP265	30 Sec. Purge, 10 & 15 Sec. TFI, 2 Sec FFRT, Pilot Stabilization, Recycle, Modulation.
EP270	30 Sec. Purge, 5 & 10 Sec. TFI, 4 Sec FFRT, Early Spark Termination, Recycle, Modulation
EP200F	Selectable Purge, Selectable TFI, 4 Sec FFRT, Recycle, Modulation, French language.
EP200S	Selectable Purge, Selectable TFI, 4 Sec FFRT, Recycle, Modulation, Spanish language.
EP380	30 Sec. Purge, 5 & 10 Sec. TFI, 4 Sec FFRT, Recycle, No Modulation
EP381	15 Sec. Purge, 5 & 10 Sec. TFI, 4 Sec FFRT, Recycle, No Modulation
EP382	0 Sec. Purge, 5 & 10 Sec. TFI, 4 Sec FFRT, Recycle, No Modulation
EP383	Selectable Purge, 5 and 10 Sec. TFI, Selectable Recycle / Non-Recycle via ED510, No Modulation, No Agency Approvals.
EP387	Selectable Purge (15 sec. min.), Selectable TFI, Selectable Recycle / Non-Recycle, No Modulation, infinite hold on M-D circuit.
EP390	90 Sec. Purge, 5 & 10 Sec. TFI, 4 Sec FFRT, Recycle, No Modulation
EP300F	4 Sec FFRT, Selectable Purge, Selectable Recycle, Non-Recycle, No Modulation, French language.
EP300S	4 Sec FFRT, Selectable Purge, Selectable Recycle, Non-Recycle, No Modulation, Spanish language.

PROGRAMMERS FOR USE WITH INTEGRATED FLAME SCANNERS

EP178	Keypad adjustable purge time, PTFI, MTFI, post purge, early spark termination, pilot proving period, and indefinite hold on low fire start. Non-Recycle, Modulation. For use with EDC1 and EDC2 amplifiers and 85UVF4-1QDWR, 85IRF4-1QDWR, or InSight scanners (with 59-497-020WR cable).
EP378	Keypad adjustable purge time, PTFI, MTFI, post purge, early spark termination, pilot proving period, and indefinite hold on low fire start. Selectable Recycle, Non-Recycle. No modulation. For use with EDC1 and EDC2 amplifiers and 85UVF4-1QDWR, 85IRF4-1QDWR or InSight scanners (with 59-497-020WR cable).

EPD Programmer Modules

Bulletins EPD-1601, EPD-2601, EPD-3801

The EPD programmers offer a cost effective version of the Flame-Monitor control. EPD style programmers provide the same start-up programming, safe start check, and flame monitoring supervision as their counterpart EP style programmers. The major difference between EP and EPD style programmers is that the EPD programmers incorporate a built-in display consisting of seven (7) LED indicator lights to annunciate the current operating status of the Flame-Monitor control, as well as the reason of the last lockout condition. EPD programmers provide a switch-selectable option that requires the air flow switch (terminals 3-P) to be open at the start of the operating cycle. The EPD programmers include an RJ45 style connector to interface with a remote alpha-numeric display (P/N ED510)¹ and two (2) RJ12 connectors for Modbus communications wired in a multi-drop configuration.

The EPD programmers do not require the ED510 alpha-numeric display to operate. The ED510 display is optional for EPD programmers, but is required for the EP-style programmers.

The EPD Flame-Monitor System can be upgraded to include an E300 Expansion Module (remote ED510 alpha-numeric display required). A set of test jacks located on the front of the programmer module provide a 0-10 VDC output to indicate flame signal strength.



PART NUMBER	DESCRIPTION
EPD160	30 Sec. Purge, 10 & 15 Sec. TFI, Non-Recycle Modulation
EPD161	30 Sec. Purge, 10 & 30 Sec. TFI, Non-Recycle, Modulation
EPD167	30 Sec. Purge, 10 & 15 Sec. TFI, Non-Recycle, Modulation, Infinite Hold on M-D circuit.
EPD170	30 Sec. Purge, 5 & 10 Sec. TFI, Early Spark Termination, Non-Recycle, Modulation
EPD260	30 Sec. Purge, 10 & 15 Sec. TFI, Recycle, Modulation
EPD261	30 Sec. Purge, 10 & 30 Sec. TFI, Recycle, Modulation
EPD270	30 Sec. Purge, 5 & 10 Sec. TFI, Early Spark Termination, Recycle, Modulation
EPD380	30 Sec. Purge, 5 & 10 Sec. TFI, Recycle, No Modulation
EPD381	15 Sec. Purge, 5 & 10 Sec. TFI, Recycle, No Modulation
EPD382	0 Sec. Purge, 5 & 10 Sec. TFI, Recycle, No Modulation
EPD390	90 Sec. Purge, 5 & 10 Sec. TFI, Recycle, No Modulation

GENERAL COMMENTS

EPD100 and EPD200 series programmers provide an additional 30 second low-fire purge.

All programmers offer selectable Prove Air Flow (3-P circuit) Open To Start feature

All programmers have 4 second FFRT.

EPD Style Programmers include a built-in LED display.



CAUTION: While programmers are mechanically interchangeable in that they mate with a common wiring base, you should select the correct model for your application. Inappropriate application of a control could result in an unsafe condition hazardous to life and property.

Selection of a control for a particular application should be made by a competent professional, such as a boiler/burner service technician licensed by a state or other government agency.

1. The EPD programmers must have an Engineering code of 02 or higher to interface with an ED510 display.

FLAME AMPLIFIER MODULES

Bulletin EAMP-1

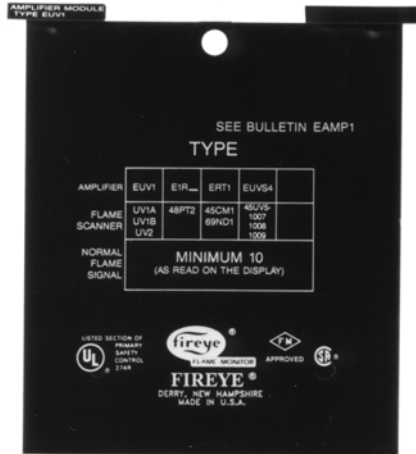

The Fireye Flame Amplifier Modules are used in conjunction with the appropriate flame scanner to provide flame scanning capability in the FLAME-MONITOR system. Fireye offers ultraviolet amplifiers (EUV1), self-check ultraviolet amplifiers (EUVS4), flame rectification amplifiers for use with flame rods and photocells (ERT1), and auto-check infrared amplifiers: E1R1 (standard model), E1R2 (high sensitivity - consult factory before use), and E1R3 (for solid fuels).

Self-checking ultra-violet scanners and amplifiers should be used in applications where burner firing operation is continuous or where the burner is on for long periods of time (e.g. 24 hours) without cycling.

The flame amplifier must be used with the appropriate flame scanners as shown below.

When replacing any flame scanner or amplifier, the burner should be cycled on and off several times to ensure proper operation.

PART NUMBER	DESCRIPTION
EUV1	UV Amplifier for UV1A, UV8A, UV2, 45UV3, UV90
E1R1	Infrared Amplifier for 48PT2 Scanner
E1R2	Infrared Amplifier (High Sensitivity) for 48PT2 Scanner. Consult factory before use.
E1R3	Infrared Amplifier (for solid fuels) for 48PT2 Scanner.
EUVS4	Self-Check UV Amplifier for 45UV5-1007, -1008, -1009, -1005
ERT1	Rectification Amplifier for 45CM1, 69ND1
EDC1	Amplifier for use with the EP178/EP378 and one or two 85UVF4-1QDWR or InSight flame scanners (with 59-497-020WR cable).
EDC2	Amplifier for use with the EP178/EP378 and one or two 85UVF4-1QDWR or InSight flame scanners (with 59-497-020WR cable) to monitor pilot and main. Scanners automatically switched at appropriate time.

E300 EXPANSION MODULE

Bulletin E-3001

The Fireye E300 Expansion Module provides increased interlock supervision capability of the Flame-Monitor control system. By wiring any of 16 interlock switches into the Expansion Module (three additional recycling interlocks and 13 additional running safety interlocks), the Flame-Monitor will automatically act as a "first out" annunciator for these interlocks. The user can select the lockout message associated with each set of terminals of the E300 from a library of messages using the ED510 display module. The user can also customize the lockout alarm messages (up to 40 characters in length) by using an IBM compatible PC, E300 software (contact Fireye), EC485 converter, and ED512 cable. The E300 Expansion Module connects to the EB700 Chassis with an E350 ribbon cable. The Expansion Module does not interfere with the normal operation of the Flame-Monitor system. It expands the diagnostic capability of the control, identifying the specific limit in the operating control circuit (LI-13) or running safety interlock circuit (3-P) which caused the burner shutdown or lockout, reducing troubleshooting time and expense.



PARTIAL LIST OF SELECTABLE MESSAGES PROVIDED USING ED510 DISPLAY MODULE

E340 OP CNTL OPEN	HIGH OIL PRESSURE	LOW OIL TEMPERATURE	E340 SAFETY INTLK OPEN
LOW GAS PRESSURE	LOW WATER	HIGH OIL TEMPERATURE	F.D.FAN INTLK
HIGH GAS PRESSURE	HIGH WATER	HIGH PRESSURE	I.D. FAN INTLK
HIGH STACK TEMPERATURE	LOW ATOMIZING MEDIA	HIGH TEMPERATURE	BLOWER MOTOR INTLK
LOW OIL PRESSURE	HIGH STACK TEMPERATURE	AIR FLOW OPEN	OIL GUN END SWITCH OPEN

PART NUMBER	DESCRIPTION
E300	120 VAC Expansion Module for Flame-Monitor
E350-3	Expansion Module cable, 3 ft.
E350-6	Expansion Module cable, 6 ft.
60-1950	Wiring Base for E300
EC485	RS232/RS485 converter for programming custom messages
UC485	USB / RS485 converter for programming custom messages
ED512-2	RJ12 connector cable - 2 ft. for programming custom messages
Contact Fireye for software for programming customized messages.	

DIMENSIONS

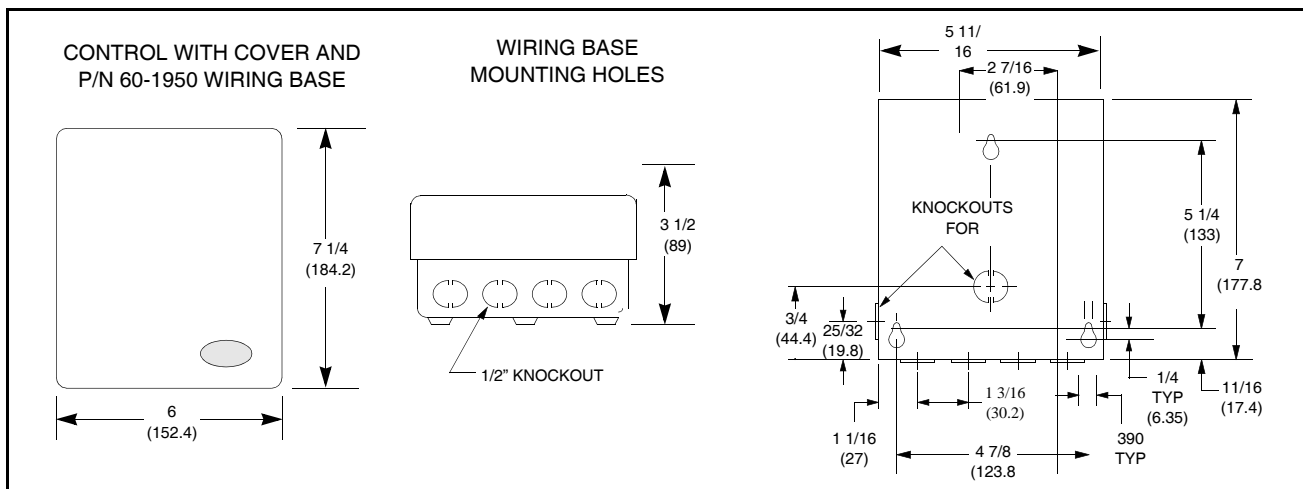



The Fireye® BurnerLogix™ System is a microprocessor based burner management control system designed to provide the proper burner sequencing, ignition and flame monitoring protection on automatically ignited oil, gas, and combination fuel burners. In conjunction with limit and operating controls, it programs the burner/blower motor, ignition and fuel valves to provide for proper and safe burner operation. Through SMART LED'S, the control provides current operating status and lockout information in the event of a safety shutdown. Optional VFD and LCD displays are available that may be either plugged in or mounted remotely to give full language descriptors of current status and diagnostic lockout information.

A complete BurnerLogix system includes the YB110 (YB230) chassis equipped with the type of flame amplifier required for the application, appropriate flame detector, plug-in programmer module, wiring base and optional alpha-numeric display. Interchangeable programmer modules allow for complete versatility in selection of function, timing and flame failure response times.

The optional alpha-numeric display is made up of 2 lines by 16 characters per line and is available in either vacuum fluorescent or liquid crystal formats. Both displays contain a fully functional keypad allowing the user to easily scroll through the various menus to view the current operating status, review programmer configuration, and lockout history. An advantage of the BurnerLogix control family is the ability to set many of the operating parameters associated with proper and reliable burner operation allowing inventory of various programmer types to be kept to a minimum.

Interchangeable YP programmer modules allow for complete versatility in selection of control function, timing, and flame scanning means. Functions such as pre-purge time, recycling or non-recycling interlocks, high fire proving interlock and trial for ignition timing of the pilot and main flame are determined by the programmer module. The BurnerLogix system can be used with ultra-violet, auto-check infrared, flame rod, self-check ultra-violet flame scanners or direct coupled integrated scanners by choosing the proper chassis/flame amplifier module.

Wiring bases for the BurnerLogix control are available pre-wired with 4 foot lead wires color coded and marked for easy installation or with an integral terminal block capable of accepting up to 2 X 14 AWG wires. The wiring base terminal block is available with knockouts for conduit or open ended for cabinet mounting. The pigtail wiring base is 4" X 5" and the terminal block wiring base is 4" X 7".

Additional functions of the BurnerLogix system include:

- A consistent flame signal read-out via display module or 4-20 mA output.
- Read-out of main fuel operational hours and complete cycles via display module.
- Modbus communications via RS485 multi-drop link.
- Proof of fuel valve closure during off cycle.
- Burn-in time of program parameters occurs after 8 hours of main valve on time.
- A run/check switch which allows the operator to stop the program sequence in any of four different positions (Purge, PTFI, MTFI or Auto).
- Remote Display mounting with NEMA 4 protection.
- Remote Reset.
- Revert to pilot can increase burner turn down.

BurnerLogix Chassis/Flame Amplifier Module

PART NUMBER	DESCRIPTION
YB110UV	120 VAC input with UV non self-check amplifier
YB110UVSC	120 VAC input with UV self-check amplifier

PART NUMBER	DESCRIPTION
YB110IR	120 VAC input with IR auto-check amplifier
YB110IR2	120 VAC input with IR auto-check amplifier (special application only -consult factory)
YB110FR	120 VAC input with flame rectification amplifier
YB110DC	120 VAC input with direct coupled amplifier for use with 85UVF4-1QDWR or InSight scanner (with 59-497-020WR cable)
YB230UV	230 VAC input with UV non self-check amplifier
YB230UVSC	230 VAC input with UV self-check amplifier
YB230IR	230 VAC input with IR auto-check amplifier
YB230FR	230 VAC input with flame rectification amplifier
YB230DC	230 VAC input with direct coupled amplifier for use with 85UVF4-1QDWR or InSight scanner (with 59-497-020WR cable)

BurnerLogix Programmer Modules

PART NUMBER	DESCRIPTION
YP100	Keypad selectable parameters, non-recycle operation, modulation, open damper proving, 4 second FFRT
YP102	Keypad selectable parameters, non-recycle operation, modulation, open damper proving, 2 second FFRT
YP138	Keypad selectable parameters, non-recycle operation, modulation, open damper proving, indefinite pilot hold, revert to pilot from auto, 4 second FFRT
YP118	Keypad selectable parameters, non-recycle operation, modulation, open damper proving, indefinite pilot hold, revert to pilot from auto, 1 second FFRT
YP200	Keypad selectable parameters, recycle operation, modulation, 4 second FFRT
YP202	Keypad selectable parameters, recycle operation, modulation, 2 second FFRT
YP300	Keypad selectable parameters, recycle operation, low fire start, early spark termination, 4 second FFRT
YP302	Keypad selectable parameters, recycle operation, low fire start, early spark termination, 2 second FFRT
YP113	Keypad selectable parameters, non-recycle operation, modulation, open damper proving, 1 second FFRT

BurnerLogix Displays

PART NUMBER	DESCRIPTION
BLV512	Display, 2 line X 16 characters, VFD, with cable, NEMA 4
BLL510	Display, 2 line X 16 characters, LCD, with cable, NEMA 4

BurnerLogix Wiring Bases

PART NUMBER	DESCRIPTION
60-2810-1	Pigtail wires, 4 foot long, 4"W x 5"H
60-2812-1	Closed base with terminal block and knockouts, 4"W x 7"H
60-2814-1	Open base with terminal block. 4"W x 7"H

BurnerLogix Accessories

PART NUMBER	DESCRIPTION
129-178-4	Kit, remote mounting, BurnerLogix display, 4 ft. cable, provides NEMA 4 protection
129-178-8	Kit, remote mounting, BurnerLogix display, 8 ft. cable, provides NEMA 4 protection
BLD500	Blank display module, included with YB module
IT1000	Alarm annunciation system using wireless technology
PPC6000	Parallel Positioning System
61-5745-3	Shutter drive assembly for redundant self-check 45UV5-1005 scanners
57YB4-5000	Tester for use with BurnerLogix YB control, 120 VAC

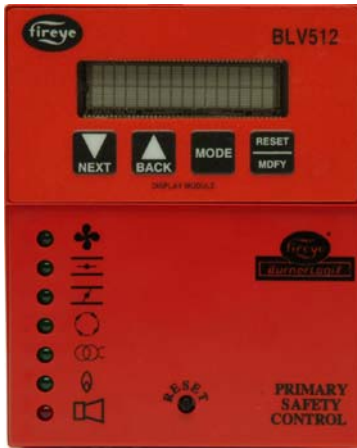

The Fireye® BurnerLogix™ Z System expands on the standard BurnerLogix Y System by combining boiler control functions with the same burner management control found in the Y system. The result is a single compact package that can directly control the boiler's output firing rate based on either input pressure or temperature or both.

The BurnerLogix Z System is designed to provide the proper burner sequencing, ignition and flame monitoring protection on automatically ignited oil, gas, and combination fuel burners. Through the display, the operator programs the desired setpoint, cut in, cut out and modulating range and with PID control, the BurnerLogix Z System controls the burner/boiler from start up through shutdown, precisely maintaining the desired setpoint.

The BurnerLogix Z System continuously monitors interlocks and limits found in the L1-3 and 3-P circuits as it programs the burner/blower motor, ignition and fuel valves to provide for proper and safe burner operation. VFD and LCD displays are available that may be either plugged in or mounted remotely to give full language descriptors of current status and diagnostic lockout information as well as provide a user friendly menu system to make setting the boiler parameters easy and understandable.

Through SMART LED'S, located on the front cover or through the display interface, the control provides current operating status and lock-out information in the event of a safety shutdown. Following are some of the major control and monitor capabilities provided by the BurnerLogix Z System:

- **Operating Control Function** for automatic sequencing of the boiler system to start and stop the boiler to meet system demand.
- **Full Modulation Control** of fuel and combustion air through the firing rate motor to meet system demand.
- **Solid State Sensors** to monitor steam pressure, water temperature, stack temperature, boiler water temperature, or outdoor air temperature.
- **High Pressure and Temperature Alarm Limits** based on inputs from solid state sensors. Exceeded limits will open interlock circuit to the flame safeguard control for shutdown of the burner and boiler.
- **Cold Start Thermal Shock Protection** to slowly increase the burner firing rate on a cold start to limit mechanical stress due to thermal differences.
- **Multiple Lead/Lag** operation of two or more boilers.
- **Remote Communication Capability** allows reading and writing of all setpoint information.
- **Assured low fire cut off** prevents unnecessary stress caused by burner shut down at high fire.
- **Auto / Manual firing rate** control with bumpless transfer

A complete BurnerLogix Z System includes the ZB110 (ZB230) chassis equipped with the type of flame amplifier required for the application, appropriate flame detector, plug-in programmer module, appropriate temperature/pressure transducer, wiring base and alpha-numeric display. Interchangeable YP1XX type programmer modules allow for complete versatility in selection of function, timing and flame failure response times.

The ZB110 (ZB230) is a chassis/flame amplifier module complete with mounting screws and blank display module. The display module (BLV512 or BLL510), if required, must be ordered separately. Functions such as pre-purge time, recycling or non-recycling interlocks, high fire proving interlock, and trial for ignition timing of the pilot and main flame are determined by the programmer module. The BurnerLogix Z System can be used with ultra-violet, autocheck infrared, flame rod, self-check ultraviolet flame scanners or direct coupled by choosing the proper chassis/flame amplifier module.

Wiring bases for the BurnerLogix Z control are available pre-wired with 4 foot lead wires color coded and marked for easy installation or with an integral terminal block capable of accepting up to 2 X 14 AWG wires. The wiring base terminal block is available with knockouts for conduit or open ended for cabinet mounting. The pigtail wiring base is 4" X 5" and the terminal block wiring base is 4" X 7".

Additional functions of the BurnerLogix Z System include:

- A non-volatile memory which allows the control to remember its history and present position even when power is interrupted.
- A consistent flame signal read-out via display module or 4-20 mA output.
- Read-out of main fuel operational hours and complete cycles via display module.
- Modbus communications via RS485 multi-drop link.
- Proof of fuel valve closure during off cycle.
- Burn-in time of program parameters occurs after 8 hours of main valve on time.
- A run/check switch which allows the operator to stop the program sequence in any of four different positions (Purge, PTFI, MTFI or Auto).
- Remote Display mounting with NEMA 4 protection.
- Remote Reset
- Keypad selectable language readout.
- Revert to pilot can increase burner turn down.

BurnerLogix Z Chassis/Flame Amplifier Module

PART NUMBER	DESCRIPTION
ZB110UV	120 VAC input with UV non self-check amplifier
ZB110UVSC	120 VAC input with UV self-check amplifier
ZB110IR	120 VAC input with IR auto-check amplifier
ZB110IR2	120 VAC input with IR auto-check amplifier (special application only - consult factory)
ZB230UV	230 VAC input with UV non self-check amplifier
ZB230UVSC	230 VAC input with UV self-check amplifier
ZB230IR	230 VAC input with IR auto-check amplifier

BurnerLogix Z Programmer Modules

PART NUMBER	DESCRIPTION
YP100	Keypad selectable parameters, non-recycle operation, modulation, open damper proving, 4 second FFRT
YP102	Keypad selectable parameters, non-recycle operation, modulation, open damper proving, 2 second FFRT
YP113	Keypad selectable parameters, non-recycle operation, modulation, open damper proving, 1 second FFRT
YP118	Keypad selectable parameters, non-recycle operation, modulation, open damper proving, indefinite pilot hold, revert to pilot from auto, 1 second FFRT
YP138	Keypad selectable parameters, non-recycle operation, modulation, open damper proving, indefinite pilot hold, revert to pilot from auto, 4 second FFRT

BurnerLogix Z Displays

PART NUMBER	DESCRIPTION
BLV512	Display, 2 line X 16 characters, VFD, with cable, NEMA 4
BLL510	Display, 2 line X 16 characters, LCD, with cable, NEMA 4

BurnerLogix Z Wiring Bases

PART NUMBER	DESCRIPTION
60-2850-1	Pigtail wires, 4 foot long, 4"W x 5"H
60-2852-1	Closed base with terminal block and knockouts, 4"W x 7"H
60-2854-1	Open base with terminal block. 4"W x 7"H

BurnerLogix Z Accessories

PART NUMBER	DESCRIPTION
129-178-4	Kit, remote mounting, BurnerLogix display, 4 ft. cable, provides NEMA 4 protection
129-178-8	Kit, remote mounting, BurnerLogix display, 8 ft. cable, provides NEMA 4 protection
BLD500	Blank display module, included with ZB module
IT1000	Alarm annunciation system using wireless technology
PPC6000	Parallel Positioning System
61-5745-3	Shutter drive assembly for redundant self-check 45UV5-1005 scanners

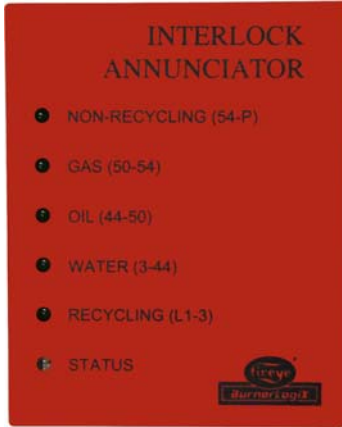

The FIREYE YZ300 (YZ320) Interlock Annunciator Module provides increased interlock supervision capability of the BurnerLogix System. The Interlock Annunciator Module connects to any YB110 (YB230) or ZB110 (ZB230) BurnerLogix chassis/amplifier by means of a cable, (P/N ED580-4, ED580-8).

By wiring any of twenty interlock switches into the Interlock Annunciator Module, the BurnerLogix display automatically acts as a “first-out” annunciator for these interlocks. In addition, a fuel selection circuit providing full annunciation even if two fuels are fired simultaneously is standard. The YZ300 (YZ320) is shipped with default messages associated with each set of terminals. The user has the ability to modify these lockout messages in one of two ways:

1. Use the BLV512 or BLL510 display module to select a lockout alarm message for the individual terminals of the YZ300 (YZ320) from a library of available messages. Refer to Bulletins BL-1001 and/or BLZ-1001 for information regarding the operation of these controls.
2. Program a customized message (up to 40 characters in length) for the individual terminals of the YZ300 (YZ320) using a compatible PC with the Windows based YZ300P Programming software, available from Fireye and the appropriate hardware. Note: The YZ300 (YZ320) Interlock Annunciator does not need to be connected to a BurnerLogix system to be custom programmed.

Note: Proper operation of the YZ300 (YZ320) requires a BurnerLogix YB110 (YB230) with an Engineering code of 3 or later or any ZB110 (ZB230) chassis/amplifier (Engineering codes are found after the date code, e.g. 0636-03).

The Interlock Annunciator Module does not interfere with the normal operation of the BurnerLogix System. It expands the message and diagnostic capability.

The wiring bases for the YZ300 (YZ320) measure 4 in. wide by 7 in. tall, consuming a minimum amount of cabinet space. The wiring bases contain a 24 position terminal block, each position clearly numbered and each terminal utilizing a clamping mechanism to assure a good mechanical connection.

The YZ300 (YZ320) Interlock Annunciator module provides operational information and reduces troubleshooting time and expense. It expands the standard display messages of the BurnerLogix to identify the specific limit in the operating control circuit (L1-3) or running interlock circuit (3-P) which caused the burner shutdown or lockout. For a detailed description of the BurnerLogix System, see Bulletins BL-1001 or BLZ-1001.

PART NUMBER	DESCRIPTION
YZ300	Interlock Annunciator Module used with the YB110 or ZB110 BurnerLogix chassis/amplifier, 120 VAC, +10%, -15%, 50/60 Hz
YZ320	Interlock Annunciator Module used with the YB230 or ZB230 BurnerLogix chassis/amplifier, 230 VAC, +10%, -15%, 50/60 Hz
60-2872-1	Wiring base, terminal blocks, closed with knockouts
60-2874-1	Wiring base, terminal blocks, open end
ED580-4, -8	YB110 or ZB110 to YZ300 interconnection cable in 4' and 8' lengths
YZ300P	Windows based software for programming custom messages
EC485	RS232 to RS485 converter with power supply. Required to customize YZ300 messages
UC485	USB to RS485 converter with USB cable. Required to customize YZ300 messages
ED512-2, 4, -8	Cable with RJ12 connectors on each end. Required to customize YZ300 lockout alarm messages

INTOUCH WIRELESS MONITORING SYSTEM

Bulletin INT-1000

The inTouch Wireless Monitoring System provides continuous monitoring up to 10 Flame-Monitor and/or MicroM flame safeguard controls. The inTouch System also provides 4 dry-contact and 4 AC power inputs. In the event of a lockout or contact closure, the inTouch system reports the condition causing the lockout and also the make, model and location of the equipment over the wireless cellular network using a wide variety of delivery methods, i.e. telephone, fax, e-mail, pager (alphanumeric, numeric). The system can be configured to provide customized messages for each monitored point and safety lockout message for the flame safeguard control. Every 24 hours, the inTouch will transmit to the server message center information about the connected flame safeguard controls, e.g. system hours, burner hours, burner cycles and total number of lockouts.



DIMENSIONS

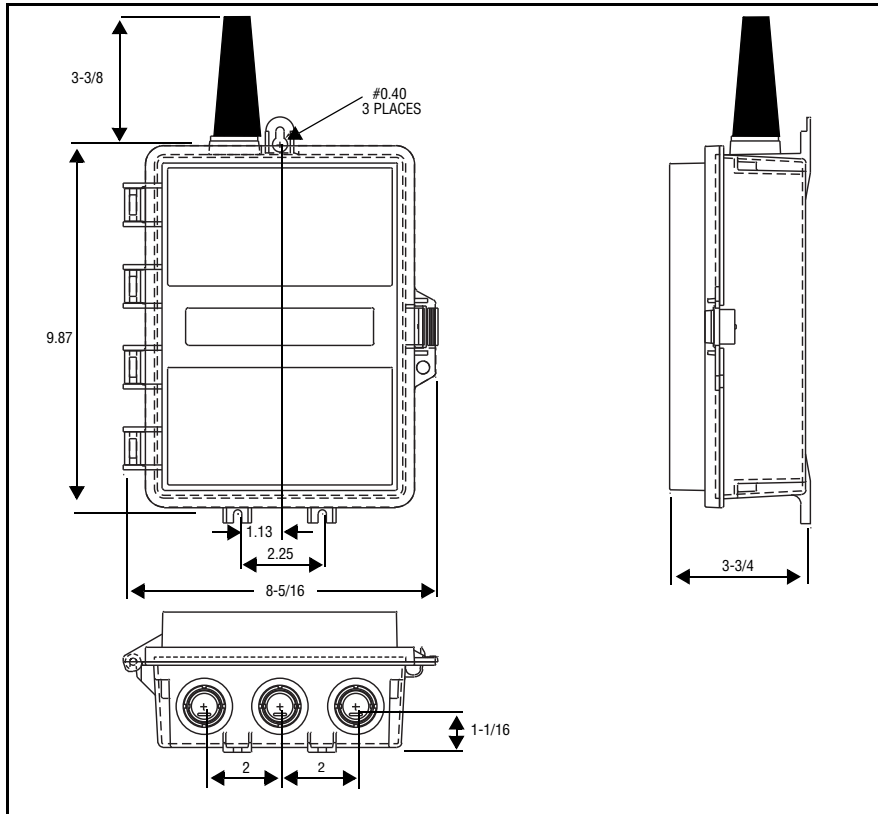

PART NUMBER	INTOUCH MAIN COMPONENT
IT1000	Monitor up to 10 Flame-Monitors, MicroM or BurnerLogix Y & Z controls, 4 dry-contact, 4 AC input. Complete with 3 Quad Band GSM antenna and communication cable.

PART NUMBER	INTOUCH ACCESSORIES
N018032-10	Remote Quad Mount Antenna without mounting kit (includes 10 ft coax cable)
N018040-KIT	Remote Quad Mount Antenna with mounting kit (includes 10 ft coax cable)
N200233-00	Remote mount U bolt - 1/2" OD pipe size (included in remote mounting kit)
N250339-00	Remote mounting bracket (included in remote mounting kit)
59-509-10,-15,-20,-25	Coax cable extension
ED512-2,-4,-8	Cable with RJ12 connector used to connect BurnerLogix and Flame-Monitor to ED-610
ED610	Telephone jack adapter board for multi-dropping controls



The Fireye **NEXUS NX6100** Integrated Controller is a microprocessor based, Flame Safeguard and Parallel Positioning Combustion Controller built into one compact, user configurable package. The system consists of the Controller, Display, Temperature / Pressure Sensors, Servo-Motors and optional Comfire Software.

The Flame Safeguard portion of the control package provides burner sequencing including safe start check, proof of main valve closure, selectable main gas safety proving sequence, supervised pre-purge, low fire starting position, pilot and main trials for ignition, main flame supervision, and post purge. Safety event timings are provided to meet North American and CE Standards. Time proven Fireeye Flame Scanners and amplification circuits using UV, UV-Self Check and Infrared sensors, provide fast reliable scanning of most commonly burned fuels. For exotic fuels and applications, the NX6100 is also compatible with Fireeye Phoenix and InSight inte-

grated Flame Scanners. Seven low voltage and two line voltage user defined auxiliary inputs provide supervision of safety critical and non-safety critical inputs. A large menu of alarm messages provides enhanced diagnostics.

Control of up to four profiles using an independent Servo-Motor for each controlled element allows precise positioning, accurate to 0.1°, of the fuel and air metering devices over the burner's firing range. Each profile can be defined to include up to 10 servomotors. Profiles can be configured to share common fuel servomotors or as independent (one profile per fuel) and are not limited by fuel. Up to 24 positions per profile including: Closed, Purge, Ignition (Preferred Start), Low Fire and an additional 20 intermediate points from low to high fire. Each individual servomotor's position and speed are verified and lockout will occur should either of these parameters be exceeded. All servomotors are controlled via secure CANbus communications link.

Modulation control is provided via the pressure/temperature sensor's input. The Fireeye NX1020, NX1030 or NX1040 sensors provide checking circuits for fail safe operation. Two PID setpoints are available for the chosen modulation input, selectable up to two decimal points. Track modulation is available for those applications requiring less precise control.

The NX6110 Twelve-Key Display allows commissioning and current status of the system through the use of its tactile membrane keypad. Multi-function keys allow the commissioning engineer the ability to access the various Ratio Modes and Option Select menus. The two line 20 character Vacuum Fluorescent Display clearly illuminates the Control Variable, Firing Mode, Fuel Selected and Hours Run. It further allows the Boiler Operator access to the Auto/Manual selector, Motor Data (servo positions) and other operational parameters such as System Sequence Position, Valve Proving Sequence Status, Gas Pressure, Flame Signal, Modulation Rate and Setpoint, as necessary.

Multiple Boiler Sequencing is accomplished through an RS485 Communications bus using Comfire software. Lead/Lag and Standby set points for up to four (4) boilers can be configured

PART NUMBER	NX6100 FUEL AIR RATIO CONTROLLER
NX6100	Stand-alone parallel positioning controller, with up to ten (10) selectable function CANbus servo-motor outputs. Includes user configurable function blocks for custom applications. Display ordered separately.

PART NUMBER	DISPLAY MODULES FOR NX6100
NX6110	12 key CANbus display for NX6100 with upload/download of NX6100 data and three programmable relays
NXTSD104	10.4" Touchscreen Display with upload/download, full commissioning, data log, internet connection.

PART NUMBER	SERVO-MOTORS FOR NX6100
NXC04	4 wire CANbus Servo-motor, 3 ft lbs., 4 Nm, 50/60 Hz, 24 VAC.
NXC12	4 wire CANbus Servo-motor, 9 ft lbs., 12 Nm, 50/60 Hz, 24 VAC.

PART NUMBER	SERVO-MOTORS FOR NX6100
NXC20, NXC20A	4 wire CANbus Servo-motor, 14.75 ft lbs., 20 Nm, 50/60 Hz, 24 VAC.
NXC40	4 wire CANbus Servo-motor, 29.5 ft lbs., 40 Nm, 50/60 Hz, 24 VAC.

PART NUMBER	EXPANSION INTERFACE MODULES FOR NX6100
NXDBMB	Modbus RTU interface card for PPC6000 / NX6100. Networks up to 15 Fireye Nexus Systems - one card per control
NXDBVSD	VSD interface daughter board with two VSD channels, one analog output, two counter inputs, two programmable relays, isolated RS485 - Modbus RTU
NX02INT	CANbus O2 interface module with Fireye and generic (4-20mA) probe inputs.

PART NUMBER	O2 PROBES FOR NX6100 ONLY
NX02PK4	O2 probe assembly (for flues 300mm to 1000mm). Includes NXIATS CANbus ambient temperature sensor, flange kit.
NX02PK6	O2 probe assembly (for flues 600mm to 2000mm). Includes NXIATS CANbus ambient temperature sensor, flange kit.
NX02PK8	O2 probe assembly (for flues 1200mm to 4000mm). Includes NXIATS CANbus ambient temperature sensor, flange kit.
NXIATS	NX6100 CANbus Inlet (ambient) Air Temperature Sensor

PART NUMBER	SENSORS FOR PPC6000 / NX3100 / NX4100 / NX6100
NX1034-1	Steam Pressure Sensor: 0-58 PSI, 0-4 bar, 1/4" BSP Includes 1/4" female BSP to 1/2" NPT male adaptor. For use with NX3100 / NX4100 / NX6100
NX1034-2	Steam Pressure Sensor: 0-58 PSI, 0-4 bar, 1/4" BSP. For use with NX3100 / NX4100 / NX6100
NX1030-1	Steam Pressure Sensor: 0-362.5 PSI, 0-25 bars, 1/2" NPT. For use with NX3100 / NX4100 / NX6100
NX1030-2	Steam Pressure Sensor: 0-362.5 PSI, 0-25 bars, 1/4" BSP. For use with NX3100 / NX4100 / NX6100
NX1040-1	Boiler Temperature Sensor: 32-302°F, 0-150°C, 6" length, 1/4" dia., thermowell required, not provided. For use with NX3100 / NX4100 / NX6100
NX1044-1	Boiler Temperature Sensor: 32-752°F, 0-400°C, 6" length, 1/4" dia., thermowell required, not provided. For use with NX3100 / NX4100 / NX6100
PXMS-15	Steam Pressure Sensor: 0 - 15 PSI, 0 - 1 bar, 4-20mA output, 1/2" NPT, non self-check (for use with PPC5000 / PPC6000 / NX3100 / NX4100 / NX6100).
PXMS-200	Steam Pressure Sensor: 0 - 200 PSI, 0 - 14 bar, 4-20mA output, 1/2" NPT, non self-check (for use with PPC5000 / PPC6000 / NX3100 / NX4100 / NX6100).
PXMS-300	Steam Pressure Sensor: 0 - 300 PSI, 0 - 21 bar, 4-20mA output, 1/2" NPT, non self-check (for use with PPC5000 / PPC6000 / NX3100 / NX4100 / NX6100).
TS350 (-2), (-4), (-8)	Temperature Sensor, Range 32°F-350°F (0-176°C), 4-20mA linear output, includes 1/2 - 14 NPT well. See bulletin BLZPTS-1 for complete description.
TS752 (-2), (-4), (-8)	Temperature Sensor, Range 32°F-752°F (0-400°C), 4-20mA linear output, includes 1/2 - 14 NPT well. See bulletin BLZPTS-1 for complete description.

PART NUMBER	SOFTWARE
NXAM	Comfire communications software on CD for Nexus and PPC controls.



The Fireye **NEXUS PPC6000** is a state of the art stand-alone parallel position system for all types of liquid or gaseous fuel fired combustion systems. When combined with a Fireye flame safeguard system such as the Fireye BurnerLogix control, the PPC6000 offers the most compact and advanced parallel positioning system available. Four fuel profiles allow the PPC6000 to accommodate a variety of applications such as two fuels, with and without, the optional variable speed drive (VSD). With each profile having up to 24 points entered to assure a smooth "curve", the micro-processor interpolates points between entered values and precisely positions fuel and air to within +/- .1 degree. This eliminates hysteresis for improved efficiency. The PPC6000 is capable of powering up to ten 24 volt servomotors supplied from the integral transformer. All servomotors and displays operate on a secure CANbus communications protocol and can be "daisy chained" together for simplified wiring. Two independent PID control loops for temperature or pressure control provide

precise, accurate control of firing rate for unmatched response to load changes. Four safety rated user definable digital inputs are standard and can be configured for functions such as lead lag, night setback, thermal shock warm up, etc. Digital inputs can also be configured as analog inputs via the optional programmable function blocks using Fireye Abacus software. Built in lead lag sequencing for up to four boilers is included in every PPC6000. More elaborate lead lag schemes may be possible using the programmable function blocks.

Two variations of multifunction vacuum florescent displays are available:

NX600 standard display provides programming, status, and fault information.

NX610 display provides automatic storage of operating parameters and profiles for upload/download to the PPC6000.

In addition, three line voltage fully programmable relays are mounted inside the display.

Other options include, two Variable speed drive (VSD) outputs via daughter board, Oxygen Trim - using Fireye's proven heated zirconia oxide probe and optional interface, a wide variety of communications platforms such as Modbus are also available.

An optional internal freely programmable logic section of the PPC6000 means that external PLC's and expensive stand-alone sequencing controls may no longer be needed. Easy to program and protect, this new feature will make the PPC6000 suitable for many unique or unusual applications. Functions such as lead lag, sequencing, feedwater control and draft control are just some of the ways this feature can be used.

Optional ComFire software allows the user to view and control all aspects of the burner system, provides real time trending and logging, upload and download of profiles and options. The user can build custom screens or import actual photographs of the combustion equipment for animation.

Summary of PPC6000 Features

- State of the art surface mount technology
- Smallest footprint available: 7.0" x 4.5" x 2.5"
- Capable up to ten servomotors powered from the control
- Two PID loops for precise process control
- Simple four wire CANbus wiring reduces time and mistakes
- Optional VSD card provides two VSD's and one Analog output
- Re-transmittal of most data as 4-20mA output (requires NXDBVSD option)
- VSD encoder feedback available
- Standby lag boiler on water temp.
- Built in lead/lag sequencing for up to four boilers
- Fully programmable function block programming allows for custom applications such as draft control or feedwater control
- Two levels of displays: Basic and Basic with Backup
- Unparalleled worldwide support

PART NUMBER	PPC6000 FUEL AIR RATIO CONTROLLER
PPC6000	Stand-alone parallel positioning controller, with up to ten (10) selectable function CANbus servo-motor outputs. Includes user configurable function blocks for custom applications. Display ordered separately.

PART NUMBER	DISPLAY MODULES FOR PPC6000
NX600	Basic CANbus display for PPC6000. No upload/download capability.
NX610	CANbus display for PPC6000 with upload/download of PPC6000 data and three programmable relays

PART NUMBER	SERVO-MOTORS FOR PPC6000
NXC04	4 wire CANbus Servo-motor, 3 ft lbs., 4 Nm, 50/60 Hz, 24 VAC.
NXC12	4 wire CANbus Servo-motor, 9 ft lbs., 12 Nm, 50/60 Hz, 24 VAC.
NXC20, NXC20A	4 wire CANbus Servo-motor, 14.75 ft lbs., 20 Nm, 50/60 Hz, 24 VAC.
NXC40	4 wire CANbus Servo-motor, 29.5 ft lbs., 40 Nm, 50/60 Hz, 24 VAC.

PART NUMBER	EXPANSION INTERFACE MODULES FOR PPC6000
NXDBMB	Modbus RTU interface card for PPC6000 / NX6100. Networks up to 15 Fireye Nexus Systems - one card per control
NXDBVSD	VSD interface daughter board with two VSD channels, one analog output, two counter inputs, two programmable relays, isolated RS485 - Modbus RTU
NX02INT	CANbus O2 interface module with Fireye and generic (4-20mA) probe inputs.

PART NUMBER	O2 PROBES FOR PPC6000 ONLY
NX02PK4	O2 probe assembly (for flues 300mm to 1000mm). Includes NXIATS CANbus ambient temperature sensor, flange kit.
NX02PK6	O2 probe assembly (for flues 600mm to 2000mm). Includes NXIATS CANbus ambient temperature sensor, flange kit.
NX02PK8	O2 probe assembly (for flues 1200mm to 4000mm). Includes NXIATS CANbus ambient temperature sensor, flange kit.
NXIATS	PPC6000 CANbus Inlet (ambient) Air Temperature Sensor

PART NUMBER	SENSORS FOR PPC6000 / NX3100 / NX4100 / PPC5000
PXMS-15	Steam Pressure Sensor: 0 - 15 PSI, 0 - 1 bar, 4-20mA output, 1/2" NPT, non self-check (for use with PPC6000 / NX3100 / NX4100 / PPC5000).
PXMS-200	Steam Pressure Sensor: 0 - 200 PSI, 0 - 14 bar, 4-20mA output, 1/2" NPT, non self-check (for use with PPC6000 / NX3100 / NX4100 / PPC5000).
PXMS-300	Steam Pressure Sensor: 0 - 300 PSI, 0 - 21 bar, 4-20mA output, 1/2" NPT, non self-check (for use with PPC6000 / NX3100 / NX4100 / PPC5000).
TS350 (-2), (-4), (-8)	Temperature Sensor, Range 32°F-350°F (0-176°C), 4-20mA linear output, includes 1/2 - 14 NPT well. See bulletin BLZPTS-1 for complete description.
TS752 (-2), (-4), (-8)	Temperature Sensor, Range 32°F-752°F (0-400°C), 4-20mA linear output, includes 1/2 - 14 NPT well. See bulletin BLZPTS-1 for complete description.

PART NUMBER	SOFTWARE
NXAM	Comfire communications software on CD for Nexus and PPC controls.



The Fireye **NEXUS PPC4000** is a state of the art stand-alone parallel positioning system for all types of liquid or gaseous fuel fired combustion systems. When combined with a Fireye flame safeguard system such as the Fireye BurnerLogix control, the PPC4000 offers the most compact and advanced parallel positioning system available. Four fuel profiles allow the PPC4000 to accommodate a variety of applications such as two fuels, with and without the optional variable frequency/speed drive (VFD/VSD). With each profile having up to 24 points entered to assure a smooth "curve", the microprocessor interpolates points between entered values and precisely positions fuel and air to within ± 0.1 degree. This eliminates hysteresis for improved efficiency. The PPC4000 is capable of powering up to ten 24 volt dc servomotors powered from the control. All servomotors and displays operate on a secure Modbus communications protocol and can be "daisy chained" together for simplified wiring. Two independent PID control loops for temperature or pressure control provide precise, accurate control of fir-

ing rate for unmatched response to load changes. Ten safety rated user definable line voltage inputs are standard and can be configured for functions such as burner on, setpoint select, lead lag, night setback, cold start thermal shock protection, etc. Built in lead lag sequencing for up to four boilers is included in every PPC4000.

The **NXD410 User Interface** provides the means to setup, monitor, and display all information from the PPC4000 Control and connected accessories. The NXD410 provides a four-line backlit LCD display screen and a multi-function tactile feel keypad. The NXD410 is panel mounted and connects directly to the PPC4000 using Fireye cable 59-562-2.

The optional **NXCESVFD** plug-in daughter board provides two independent VFD/VSD channels. Each channel provides a precision 4-20 mA output to control the VFD, a calibrated 4-20 mA input, and an encoder input for VFD positional feedback.

The optional **NXCES02** Oxygen Probe provides continuous oxygen concentration readings using Fireye's proven heated zirconium dioxide technology. The NXCES02 allows the PPC4000 to trim the air or fuel servo to obtain optimum combustion efficiency.

Summary of PPC4000 Features

- State of the art surface mount technology
- Small footprint: 5.0"W x 8.0"H x 4.0"D
- Capable of powering up to ten servomotors
- Two PID loops for precise process control
- Simple four wire Modbus wiring reduces time and mistakes
- Optional NXCESVFD card provides two VFD/VSD outputs
- Optional NXCES02 Oxygen Probe provides O2 trim
- Built in lead/lag sequencing for up to four boilers
- User interface: four line LCD display screen with multifunction keypad.
- SD (secure digital) card interface for backup and restore.
- Unparalleled worldwide support

Part Number	Control
PPC4000	Stand-alone parallel positioning controller, with up to ten (10) selectable function Modbus servo-motor outputs. User interface ordered separately.
NXCESVFD	Plug-in assembly provides variable frequency (VFD/VSD) capability
60-2926	Enclosure, 12.5" x 10.5" x 6.5", UL listed, fitted for PPC4000
129-190	Kit, fan replacement
User Interface for PPC4000	
NXD410	User Interface with keypad, 24 VDC operation, 4 line back lit LCD display, panel mount only, includes mounting brackets.
59-562-2	Cable assembly, 10 feet length, for interfacing NXD410 to PPC4000
Servos for PPC4000	
FX04	Servo motor, 24 VDC operation, 4Nm, 3 lb.-ft. torque, without connectors, accepts 1/2 inch NPT fitting, minimum travel time of 30 seconds for 90°
FX04-1	Servo motor, 24 VDC operation, 4Nm, 3 lb.-ft. torque, with connectors, minimum travel time of 30 seconds for 90°
FX20	Servo motor, 24 VDC operation, 20Nm, 15 lb.-ft. torque, without connectors, accepts 1/2 inch NPT fitting, minimum travel time of 30 seconds for 90°
FX20-1	Servo motor, 24 VDC operation, 20Nm, 15 lb.-ft. torque, with connectors, minimum travel time of 30 seconds for 90°
FX50	Servo motor, 24 VDC operation, 50Nm, 37 lb.-ft. torque, without connectors, accepts 1/2 inch NPT fitting, minimum travel time of 30 seconds for 90°
FX50-1	Servo motor, 24 VDC operation, 50Nm, 37 lb.-ft. torque, with connectors, minimum travel time of 30 seconds for 90°
Servo Cables for PPC4000	
59-565-6	Cordset, 6 feet, 1/2" NPT connectors on both ends, PVC jacket, temperature rating -40°C to 105°C, meets NEMA 1,3,4,6P and IEC67
59-565-40	Cordset, 40 feet, 1/2" NPT connectors on both ends, PVC jacket, temperature rating -40°C to 105°C, meets NEMA 1,3,4,6P and IEC67
Connector Kit for PPC4000	
129-192	Connector, field wireable. Used for FX04-1, FX20-1, FX50-1 servos with connectors. Use cable 59-565
59-565	Cable, 1 twisted pair, 2 power wires, suitable for servo hookup
O2 Probe for PPC4000	
NXCES02-8	O2 probe assembly, 8" insertion
NXCES02-16	O2 probe assembly, 16" insertion
NXCES02-30	O2 probe assembly, 30" insertion
NXCES02P42, -1	Cartridge, probe replacement (model -1 for engineering code 00 only)
35-381-2	Flange, O2 probe mounting
129-189	Cover, mounting flange
Pressure Transducers for PPC4000	
BLPS-15, -25, -30	Pressure transducer, 0 to 15 psi (0 to 1030 mb), -14.7 to 25 psi (-1013 to 1720 mb), 0 to 30 psi (0 to 2070 mb), 4-20 mA output linear with pressure. 1/4" NPTF mounting. Screw terminal connections and conduit adapter cover.
BLPS-200	Pressure transducer, 0 to 200psi (0 to 13.8 Bar), 4-20 mA output linear with pressure. 1/4" NPTF mounting. Screw terminal connections and conduit adapter cover.
BLPS-300	Pressure transducer, 0 to 300 psi (0 to 20.7 Bar), 4-20 mA output linear with pressure. 1/4" NPTF mounting. Screw terminal connections and conduit adapter cover.
Temperature Transducers for PPC4000	
TS350-2, -4, -8	Temperature sensor, Range 32°F to 350°F (0°C to 176°C), 4-20 mA output, linear with temperature. Insertion length is 2, 4, 8 inches. Stainless steel thermowell included.
TS752-2, -4, -8	Temperature sensor, Range 32°F to 752°F (0°C to 400°C), 4-20 mA output, linear with temperature. Insertion length is 2, 4, 8 inches. Stainless steel thermowell included.



The E210 (220VAC) and E211 (120VAC) meet European standards for single or dual fuel fired burners, pilot ignited or direct ignited continuous duty. The ED510 Display Module (built-in or remote use) indicates the program sequence and reasons for burner shut-down in English, French, Spanish, Dutch, Swedish or German. The E210 with EP113 programmers (Eng. code 21 or higher), is compatible with the ED510 display module, providing both current and historical burner information.

Several operational characteristics of the EP113 programmer modules (with Engineering code 21 or later) are selectable via six dipswitches located on the side of the programmer. These characteristics include non-recycle or recycle operation (3-P circuit), interrupted or intermittent operation of terminal 5, extended purge timing, and the option to enable or disable the requirement that the 3-P running interlock circuit is proven open at the start of the operating cycle. A "run-check" switch on the top of the programmers (with Eng. code 21 or later) allows the operator to stop the program sequence at any time except MTFI. This aids in the set-up and adjustment of the burner linkages, pilot assembly, etc.

There are four different detection methods (infrared, flame rectification, ultraviolet, and ultraviolet self-check) and a corresponding selection of scanners.

DIMENSIONS

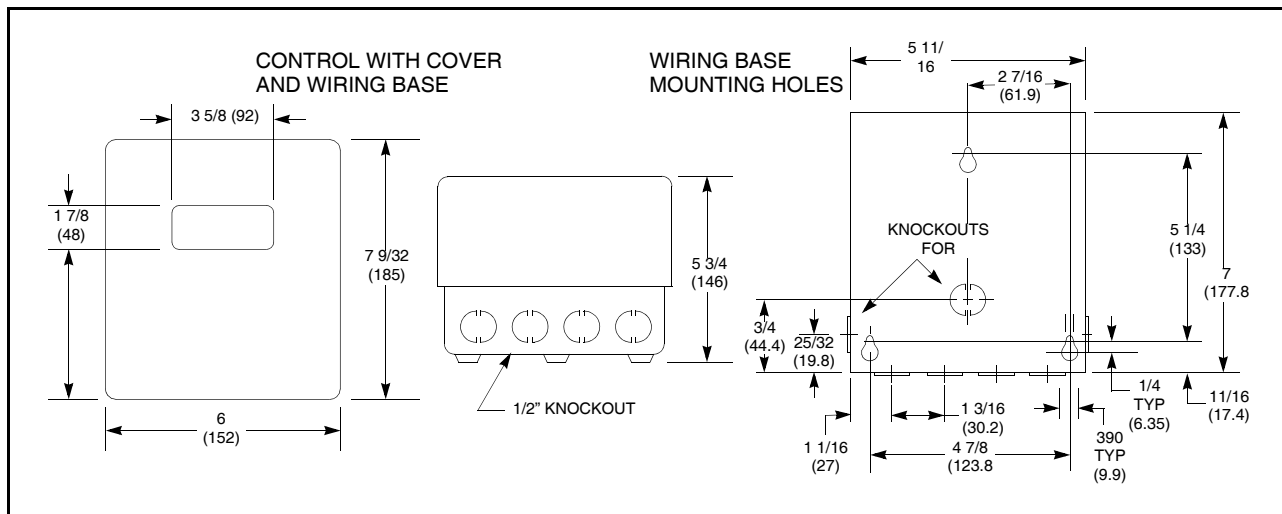

PART NUMBER	DESCRIPTION
E210	230VAC 50/60HZ Chassis. Display ordered separately. For use with EP113 programmers only.
E211	120VAC Chassis. Display ordered separately. For use with EP113 programmers only
EB720	Replacement Chassis for E210.
EB721	Replacement Chassis for E211.
ED510	2 Line x 16 Character LCD Display. Compatible with EP programmers with Eng. code 21 or higher.
48-1836	Mounting Screw (E210/E211)
48-1805	Mounting Screw (E200/201)
60-1386-2	Wiring base - Surface mount
60-1466-2	Wiring Base - Cabinet mount
14-64	Noise Line Filter for E210/E211.

PART NUMBER	AMPLIFIERS
EUV1	UV Amplifier for UV1A, UV8A, UV2, 45UV3
EIR1	Infrared Amplifier for 48PT2 Scanner
EIR3	Infrared Amplifier (w/o Oil Fog Rejection Circuit) for 48PT2 Scanner
EUVS4	Self-Check Amplifier for 45UV5-1007, -1008, -1009
ERT1	Rectification Amplifier for 45CM1, 69ND1

PART NUMBER	PROGRAMMERS
EP113E	English, selectable purge, selectable recycle/nonrecycle, selectable intermittent/interrupted operation, 3 & 5 sec. MTFI.
EP113F	French, selectable purge, selectable recycle/nonrecycle, selectable intermittent/interrupted operation, 3 & 5 sec. MTFI.
EP113D	German, selectable purge, selectable recycle/nonrecycle, selectable intermittent/interrupted operation, 3 & 5 sec. MTFI.
EP113NL	Dutch, selectable purge, selectable recycle/nonrecycle, selectable intermittent/interrupted operation, 3 & 5 sec. MTFI.
EP113ES	Spanish, selectable purge, selectable recycle/nonrecycle, selectable intermittent/interrupted operation, 3 & 5 sec. MTFI.
EP113NR	NON-RECYCLE OPERATION ONLY. Selectable pre-purge. Australian Gas approved. For use with E200/E201/E211 only. Messages in English. CE approved.
EP113SW	Swedish, selectable purge, selectable recycle/nonrecycle, selectable intermittent/interrupted operation, 3 & 5 sec. MTFI.

E320 EXPANSION MODULE

Bulletin E-3001



The Fireye E320 Expansion Module provides increased interlock supervision capability of the Flame-Monitor system. The Expansion Module connects to any EB720 Flame-Monitor chassis with a ribbon cable. It is used exclusively with the 220V/240V Flame-Monitor system. By wiring any of sixteen interlock switches into the expansion module, the Flame-Monitor display will automatically act as a "first-out" annunciator for these interlocks. In addition, a fuel selection circuit is standard.

The user can select the lockout message associated with each set of terminals of the E320 from a library of messages when using the ED510 display module. The user can also customize the lockout alarm messages (up to 40 characters in length) by using an IBM compatible PC, E300 software, EC485 converter, and ED512 cable. The expansion module does not interfere with the normal operation of the Flame-Monitor system. It expands the message and diagnostic capability. The E320 problem solving system provides operation information and reduces troubleshooting time and expense. It expands the standard display messages of the Flame-Monitor system.

DIMENSIONS

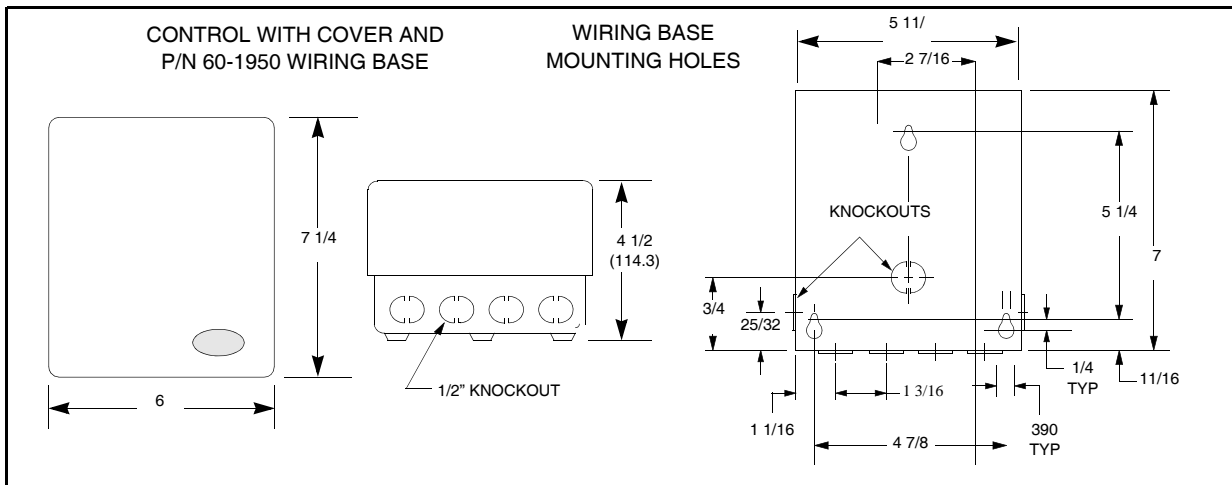

PART NUMBER	DESCRIPTION
E320	230 VAC Expansion Module for Flame-Monitor control
E350-3	Expansion Module Cable 3 ft.
E350-6	Expansion Module Cable 6 ft.
60-1950	Wiring Base for E320
EC485	RS232/RS485 converter for programming customized messages.
ED512-2	RJ12 connector cable - 2 feet for programming customized messages.

FIREYE® Series D40-41 Burner Management Controls provide ignition and flame failure protection for manually started oil or gas burners. Plug-in Amplifier Modules permit the selection of ultraviolet, repetitive self-check ultra-violet, AUTOCHECK infrared, or rectification methods of flame detection. The control system includes a safe start check, effective on each start. If flame signal (real or simulated) is detected, the unit cannot be started. For increased safety and reliability, Fireye 72D1R3 AUTOCHECK infrared amplifier (using the pulsing flame signal) and 72DUVS ultraviolet amplifier (using a scanner shutter) check the function of the flame detecting system for component failure during each burner firing cycle. Meter test jacks on each amplifier module provide flame signal readout with a DC voltmeter. Flame failure response time is four seconds (max.). When amplifier modules with T suffix are used, the flame failure response time is reduced to one second (max.). The control provides three SPDT and one SPNO load switches for external loads and starting circuits. Fireye D40-41 Burner Management controls may be adapted to a simple control system or as a building block with auxiliary devices to provide additional functions.



Note: The fireye Series D10, D20 and D30 burner management controls and programmers are no longer available. They may be upgraded to an E110 control per the table on the following page.

PART NUMBER	DESCRIPTION
70D10	Obsolete, Upgrade to an E110 control per the table on the following page.
70D20	Obsolete, Upgrade to an E110 control per the table on the following page.
70D21	Obsolete. Replace with E120 Chassis and EP260 Programmer.
70D30	Obsolete, Upgrade to an E110 control per the table on the following page.
70D40	Chassis, 120 VAC, Semi-automatic, no programmer.
70D41	Chassis, 230VAC model of 70D40.
60-1386-2	Wiring Base for surface mounting.
60-1466-2	Wiring Base for cabinet mounting.
AMPLIFIERS	
72D1R1	Infrared autocheck, 2-4 second FFRT. Use with 48PT2.
72D1R1T	Infrared autocheck, 1 second FFRT. Use with 48PT2.
72D1R3	Infrared autocheck solid fuel only. 2-4 second FFRT. Use with 48PT2.
72D1R3T	72D1R3 with 1 second FFRT. Use with 48PT2.
72DRT1	Flame rectification, 2-4 second FFRT. Use with 69NDI or 45CM1.
72DRT1T	71DRT1 with 1 second FFRT. Use with 48PT2.
72DUV1	Ultraviolet, 2-4 second FFRT. Use with UV1A, UV8A, UV2, 45UV3.
72DUVS1T	72DUVS1 with 1 second FFRT.
72DUVS4	UV self-check, 2-4 second FFRT. Use with 45UV5-1007, -1008, -1009.
PROGRAMMERS	
71D60	Obsolete, Upgrade to an E110 control per the table on the following page.
71D61	Obsolete, Upgrade to an E110 control per the table on the following page.
71D70	Obsolete, Upgrade to an E110 control per the table on the following page.
71D80	Obsolete, Upgrade to an E110 control per the table on the following page.
71D81	Obsolete, Upgrade to an E110 control per the table on the following page.
71D90	Obsolete, Upgrade to an E110 control per the table on the following page.

DIRECT REPLACEMENT UPGRADES

No wiring changes necessary (see Notes)
Use existing wiring base and flame scanner.

C-Series or D-Series to E110 Flame-Monitor

C-SERIES MODEL	D-SERIES	FLAME-MONITOR
25CU6-5065	70D10, 71D60 72DUV1	E110, ED510, EP160, EUV1
25CU6-5066	70D20, 71D60 72DUV1	E110, ED510, EP260, EUV1
26CF6-5022	70D10, 71D60 72D1R1	E110, ED510, EP160, E1R1
26CF6-5023	70D20, 71D60 72D1R1	E110, ED510, EP260, E1R1
25CU6-5062*	70D30, 71D80 72DUV1	E110, ED510, EP380, EUV1
25CU6-5063*	70D30, 71D90 72DUV1	E110, ED510, EP390, EUV1
26CF6-5020	70D30, 71D80 72D1R1	E110, ED510, EP380, E1R1
26CF6-5021	70D30, 71D90 72D1R1	E110, ED510, EP390, E1R1
24CJ5-5010	70D30, 71D80 72DRT1	E110, ED510, EP380, ERT1
24CJ5-5011	70D30, 71D90 72DRT1	E110, ED510, EP390, ERT1

Notes:

L1-13, 13-3 circuits: Some C-Series and D-Series controls were installed on a burner that did not have a fuel valve end switch terminal (13 – 3) and the operating control was wired between L1 and 3. When upgrading to a Flame-Monitor on these installations, after verifying a fuel valve end switch is not installed (e.g., no wire on terminal 13), jumper terminal 13 to 3.

Early Spark Termination (Terminal X): On the non-modulating C-Series and D-Series (70D30) controls, terminal X would provide a 5 second pilot trial for ignition (PTFI). If terminal X is required, terminal 5 must be jumpered to terminal 10 when using the EP380, EP381, or EP390 programmers.

* No terminal 10 (open damper purge) on D-Series of Flame-Monitor. Add timer if terminal 10 is used for open damper.

D-Series to Flame-Monitor

D-SERIES CHASSIS AND PROGRAMMER	E-SERIES PROGRAMMER	
70D10 and 71D60	EP160	All Flame-Monitor controls require an E110 chassis and ED510 display module.
70D10 and 71D61	EP161	
70D10 and 71D70	EP170	
70D20 and 71D60	EP260	
70D20 and 71D61	EP261	
70D20 and 71D70	EP270	
70D30 and 71D80	EP380	
70D30 and 71D81	EP381	
70D30 and 71D90	EP390	
D-SERIES AMPLIFIER	E-SERIES AMPLIFIER	USE WITH FLAME SCANNERS
72DUV1	EUV1	UV1A, UV2, UV8A, UV90, 45UV3-1050
72D1R1	E1R1	48PT2
72DRT1	ERT1*	45CM1, 69ND1
72DUVS4	EUVS4	45UV5-1007, -1008, -1009



CAUTION

Refer to Bulletin E-1101 for proper installation, grounding, operational and safety checkout procedures. Perform safety checks of the entire system prior to allowing fuel entry to boiler.

*Ensure S2 is connected to earth ground **when using ERT1**.

MicroM SERIES

Bulletins MC-5000, MAMP-1, MOPT-1, MP-5201, UM-2

The Fireye MicroM Flame Safeguard controls are compact, modular burner management systems designed to provide automatic ignition and continuous flame monitoring for commercial sized heating and process burners firing any type of fuel. The MicroM is designed to be backward compatible with existing M-Series controls. The MicroM, through the use of micro-controller technology, incorporates “smart” diagnostic LED’s, optional alphanumeric display (ED510), remote reset capability, and serial communications via MODBUS or E500 Communication Interface. These options are available through plug-in option boards to the chassis. The optional ED510 display can be utilized to access burner hours and cycles, system hours, the last 6 lockouts with burner cycle time stamp and programmer configuration. The optional MODBUS communications capability allows the integration of the MicroM control into upper level energy management / data acquisition systems.



A complete MicroM system consists of the appropriate flame scanner/detector, plug-in amplifier and programmer modules connected into a standard chassis and wiring base. Interchangeable programmer and amplifier modules allow complete versatility when selecting control function, timing, and flame scanning method. Functions such as relight, two-stage capability, purge timing, and pilot cutoff are determined by the programmer module. Type of flame scanner (UV, UV self check, infrared, flame rod, photocell, and cadmium cell) and Flame Failure Response Time (FFRT) are determined by the amplifier module. All amplifiers are available with flame failure response times of 0.8 seconds or 3 seconds nominal (4 seconds max), and each provide a set of test jacks with a range of 0-10 VDC for the measurement of flame signal intensity.

Some programmer modules (MEP200 and MEP500 series) have dipswitches for selecting purge timing, pilot trial-for-ignition (PTFI) timing, recycle or non-recycle operation, prove air flow open at start, and post purge. Smart LED indicators on all of the programmer modules indicate the current operating status of the control and, during a safety lockout, display the fault as a coded sequence, simplifying the troubleshooting of a shutdown. A “run-check” switch is provided on the MEP500 series programmers to assist in testing the size, position, and stability of the pilot. The MicroM control incorporates a safety checking circuit that is operative on each start. If flame (real or simulated) is detected prior to a start or during purge, the fuel valves will not be energized and the control will lockout.

DIMENSIONS

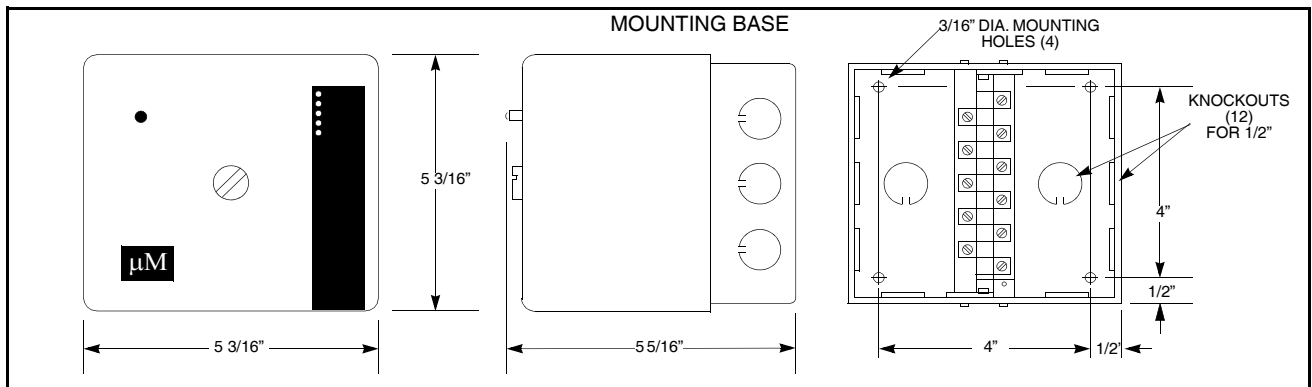

PART NUMBER	MicroM Chassis Types for use with MEP100, 200 and 500 series programmers
MEC120	120 VAC input with standard plug-in board
MEC120R	120 VAC input with remote reset capability
MEC120D	120 VAC input with alpha-numeric display interface to ED510
MEC120C	120 VAC input with interface to E500 Communication Interface and Modbus capability.
MEC120RC	120 VAC input with remote reset capability, alpha-numeric display interface to ED510, interface to E500 Communication Interface and Modbus capability
MEC120RD	120 VAC, 50/60 Hz Chassis with remote reset capability and interface to ED510.
MEC230RC	230 VAC, 50/60 Hz Chassis with remote reset capability, interface to ED510, interface to E500 Comm. Interface, and Modbus capability.
MEC230	230 VAC input with standard plug-in board.

PART NUMBER	MicroM Programmer Models, for use with MEC120/MEC230 chassis
MEP100	Relight operation, 10 sec. PTFI
MEP101	Relight operation, allow flame signal during "off cycle"
MEP102	Non-recycle on flame fail, 5 second PTFI
MEP103	Fixed 10 second PTFI, 10 second MTFI, re-try once on pilot failure, post purge
MEP104	Non-recycle on flame fail, 10 second PTFI
MEP105	Non-recycle on flame fail, lockout on air flow open with flame present, 10 FTFI.
MEP106	Relight operation, 12 sec purge, 10 sec PTFI, reset lockout on line power interruption.
MEP107	5 sec purge, 10 second PTFI, 5 minute delay following flame failure. For natural draft atmospheric gas burners
MEP108	Non-recycle operation, 0 sec purge, 15 second PTFI, 10 sec-ond post purge, no FM Approval.
MEP109	Immediate ignition and pilot after limits are closed, 10 sec PTFI (fixed), 10 sec MTFI, intermittent pilot, non-recycle on flame fail.
MEP100P	Relight operation, 10 sec PTFI, 15 second post purge.
MEP130	Relight operation, 30 sec PTFI, no agency approvals
MEP141	30 sec purge, 5 sec PTFI, 15 sec post purge, Prove air at start, 8 sec pilot stabilization, non-recycle on flame fail.
MEP149	30 sec purge, 5 sec PTFI, 90 sec post purge, prove air at start, 8 sec pilot stabilization, non-recycle on flame fail.
MEP230	Selectable purge timing, PTFI timing, recycle/non-recycle, post purge, prove air open at start
MEP230H	Same as MEP230 with 8 second pilot stabilization
MEP235	Same as MEP230 with lockout on air flow open 10 seconds after the start of a cycle, selectable recycle/nonrecycle lockout on air flow open after flame is proven and dedicated lockout after loss of flame.
MEP236	Same as MEP230 with additional 6 second igniter on time with main fuel. To be used with intermittent pilot only.
MEP238	Selectable recycle/non-recycle function, TFI timing, purge timing, post purge, prove open at start. Ignition de-energized 3 seconds after pilot detected. Provides 8 second pilot stabilization period.
MEP290	Same as MEP230 except selectable post purge is 0 or 90 seconds.
MEP437	Valve proof of closure, selectable purge, PTFI timing, intermittent or interrupted, recycle / non-recycle operation, reset by power interruption of manual reset.
MEP536	Same as MEP236, 10 second trial for ignition, run-check switch, will not lockout on air flow open during purge.
MEP537	Selectable purge, PTFI, post purge, prove open at start, recycle/non-recycle (with one recycle on flame fail), 10 sec MTFI.
MEP560	Same as MEP230H, 10 second main trial for ignition, run-check switch
MEP561	Same as MEP560 without pilot stabilization
MEP562	Same as MEP560, lockout on loss of air flow, non-recycle operation only
MEP564	Same as MEP560 except purge timings are 7 30, 60, and 240 (4 minutes) seconds.

PART NUMBER	MicroM Series MEC320 Chassis for use with MEP300 and 600 Series Programmers
MEC320	MicroM chassis with local reset; 120 VAC, 50/60 Hz, provides independent relay outputs on terminals 3 and 4. For use with MEP300 and MEP600 series programmers.
MEC320R	MicroM MEC320 chassis with remote reset. For use with MEP300 and 600 series programmers.
MEC320D	MicroM MEC320 chassis with alpha-numeric display interface to ED510. For use with MEP300 and 600 series programmers.
MEC320C	MicroM MEC320 chassis with interface to E500 Communication Interface and Modbus capability. For use with MEP300 and 600 series programmers.
MEC320RC	MicroM MEC320 chassis with remote reset capability, interface to ED510, interface to E500 Comm. Interface, and Modbus capability. For use with MEP300 and 600 series programmers.
MEC320RD	MicroM MEC320 chassis with remote reset capability and interface to ED510. For use with MEP300 and 600 series programmers.
MEC320TS	MicroM MEC320 chassis with remote communications and independent relay output. For use with MEP696 programmer only.
MEC480	MicroM chassis with local reset; 230 VAC, 50/60 Hz, pro-vides independent relay outputs on terminals 3 and 4. For use with MEP300 and 600 series programmers.

PART NUMBER	Programmers for use with MEC320 / MEC480 Chassis
MEP300	Relight operation on main flame fail, lockout on PTFI and MTFI flame fail, 10 sec PTFI (fixed), 5 sec pilot proving, 5 sec MTFI.
MEP304	5 sec purge, 10 sec PTFI (fixed), 5 sec pilot proving, 10 sec MTFI, interrupted pilot, interrupted ignition, non-recycle on flame fail.
MEP397	15 sec purge, provides interrupted ignition, interrupted pilot, non re-cycle on flame fail.
MEP696	Provides selectable PTFI, selectable baud rate, and selectable recycle / non-recycle operation. For use with MEC320TS chassis only.
MEP697	Selectable TFI timing, purge timing, post purge, prove open at start, and recycle / non-recycle on flame fail. Includes 5 sec pilot proving, early spark termination, 5 sec MTFI, and interrupted pilot.

PART NUMBER	MicroM Amplifier Models (common for all controls)
MEUV1	UV amplifier, 0.8 second FFRT, uses UV1A, UV2, UV8A and 45UV3-1050 scanners
MEUV4	UV amplifier, 3 second FFRT, uses UV1A, UV2, UV8A and 45UV3-1050 scanners
MEUVS1	UV Self-Check amplifier, 0.8 second FFRT, uses 45UV5-1007, -1008, -1009 scanners
MEUVS4	UV Self-Check amplifier, 3 second FFRT, uses 45UV5-1007, -1008, -1009 scanners
MERT1	Flame Rod / Photocell amplifier, 0.8 second FFRT, uses 69ND1 or 45CM1
MERT4	Flame Rod / Photocell amplifier, 3 second FFRT, uses 69ND1 or 45CM1
MEIR1	Infrared amplifier, 0.8 second FFRT, uses 48PT2 scanner
MEIR4	Infrared amplifier, 3 second FFRT, uses 48PT2 scanner
MECD1	Cadmium sulfide amplifier, 0.8 second FFRT, uses CS1A5 scanner
MECD4	Cadmium sulfide amplifier, 3 second FFRT, uses CS1A5 scanner

PART NUMBER	Optional Plug-In Board Module (common for all controls)
MED1	Standard local reset switch
MED2	Same as MED1 with display output
MED3	Same as MED1 with remote reset
MED4	Same as MED1 with display output and remote reset
MED5	Same as MED1 with display output and communications
MED6	Same as MED1 with display output, remote reset and communications
MED7	Same as MED1 with communications

PART NUMBER	Wiring Base (Common for All Controls)
61-3060	Closed wiring base, surface mounting
61-5042	Open wiring base, cabinet mounting

PART NUMBER	Programmers and Flame Amplifiers for use with Integrated Flame Scanners
MEP237	Programmer, Selectable recycle/non-recycle function, TFI timing, purge timing, post purge, prove open at start. Provides 0.30 second flame failure response time, for use with Phoenix and InSight flame scanner and MEDC2 amplifier.
MEDC2	Amplifier for use with dry contact input from Phoenix and InSight flame scanner. 0.30 sec FFRT. Use with MEP237 and 85UVF4-1QDWR, 85IRF4-1QDWR, or InSight scanner (with 59- 497-020WR cable).

M-SERIES II

Bulletins C -4000, C -4001, C -4002



CHASSIS (shown with Programmer Module)

Fireeye modular M-Series II Flame Safeguard controls are compact, modular burner management systems. They provide automatic ignition and continuous flame monitoring for commercial-sized heating and process burners using gas and/or light oil fuels.

Flame sensing is accomplished by miniature UV scanners or Flame Rod/ Photocell detectors and plug-in amplifier and programmer modules connected into a standard chassis and wiring base. Interchangeable programmer and amplifier modules allow complete versatility when selecting control function, timing, and flame scanning means. Functions such as relight, two stage capability, purge timing, and pilot cutoff are determined by the programmer module. Type of flame scanner (UV, flame rod, or photocell) and Flame Failure Response Time (FFRT) are determined by the amplifier module. Some programmer modules have dipswitches for selecting purge timing, pilot trial-for-ignition (PTFI) timing, and recycle or non-recycle operation. LED indicator lights on all pro-

grammer modules indicate operating status of the control.

In the event of ignition failure, or after a safety shutdown, the unit locks out, activating an alarm circuit. Manual reset is required. Remote reset (via remote push-button or power interruption) is available on the MC120R chassis. Post purge is available on the MC120P chassis. Test jacks permit flame signal measurement during operation. A "run-check" switch on the MP560, MP561, MP562 programmer module assists in testing size, position, and pilot stabilization.

Modular M-Series II controls incorporate a safety checking circuit that is operative on each start. If flame (real or simulated) is detected before a start or during the purge, the fuel valves will not be energized, and the unit will lock out.

DIMENSIONS

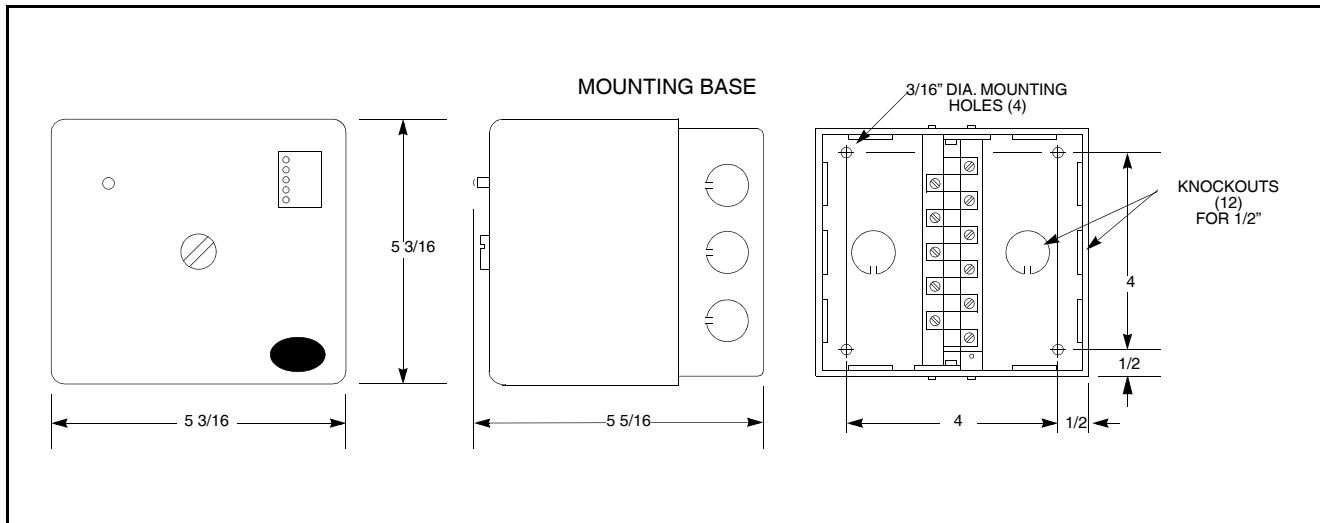

PART NUMBER	DESCRIPTION
MC120	120 VAC 50/60 Hz Chassis.
MC120E	120 VAC 50/60 Hz Chassis. Meets European EN230, EN298 approval.
MC120P	120 VAC 50/60 Hz Chassis with Remote Reset and Post Purge Capability.
MC120R	120 VAC 50/60 Hz Chassis with Remote Reset Capability.
MC120RE	120 VAC 50/60 Hz Chassis with Remote Reset Capability. Meets European EN230, EN298 approval.
MC230	230 VAC Chassis.
MC230R	230 VAC Chassis with Remote Reset Capability.



AMPLIFIER MODULE

PART NUMBER	DESCRIPTION
MP100	Relight function.
MP100E	Relight function. For MC230 only.
MP101	Relight function. Will ignore flame signal during "off" cycle.
MP102	Similar to MP100. Relight feature eliminated, 5 sec. TFI, lockout on flame failure.
MP102E	Same as MP102. For MC230 only.
MP230	Selectable recycle/non-recycle function, T.F.I. and purge timing.
MP230H	Selectable recycle/non-recycle function, T.F.I. and purge timing. Pilot stabilization, two stage capability.
MP560	Selectable recycle/non-recycle function, T.F.I. and purge timing. Pilot cut-off, pilot stabilization, check-run switch.
MP561	Same as MP560 without Pilot Stabilization.
MP562	Same as MP560 with lockout on loss of airflow. Non-recycle.



PROGRAMMER MODULE

PART NUMBER	DESCRIPTION
MAUV1	UV Amp., 2 - 4 sec. FFRT. Use with UV1, UV2, 45UV3.
MAUV1T	UV Amp., .8 sec. FFRT. Use with UV1, UV2, 45UV3.
MAUV3	UV Amp., 3 sec. FFRT. Use with UV1, UV2, 45UV3.
MART1	Flame Rect. Amp., 2 - 4 sec. FFRT. Use with 69ND, 45CM.
MART1T	Flame Rect. Amp., .8 sec. FFRT. Use with 69ND, 45CM.
MART3	Flame Rect. Amp., 3 sec. FFRT. Use with 69ND, 45CM.

PART NUMBER	DESCRIPTION
23-176	Replaceable Fuse. M-Series II programmer modules. Littelfuse 0225008, 2AG 8 amp, 125 V.
23-183	Replaceable Fuse. MP100E programmer module. Littelfuse 022903.5, 3.5 amp 250 V.
57AV7-1000	Tester for M-Series, M-Series II and MicroM.
61-3060	Closed wiring base, surface mounting.
61-5042	Open wiring base, cab. mounting.

M-SERIES TO M-SERIES II TO MICROM CROSS REFERENCE LISTING

M-SERIES	M-SERIES II REPLACEMENT MODULES				MicroM REPLACEMENT MODULES			
Part Number	Chassis	Amplifier	Programmer	Programmer Dipswitch #8	Chassis	Amplifier	Programmer	Programmer Dipswitch #6
UVM1D	MC120	MAUV1T	MP100	N/A	MEC120	MEUV1	MEP100	N/A
UVM1F	MC120	MAUVI	MP100	N/A	MEC120	MEUV4	MEP100	N/A
TFM1D	MC120	MART1T	MP100	See Note #1	MEC120	MERT1	MEP100	N/A
TFM1F	MC120	MART1	MP100	See Note #1	MEC120	MERT4	MEP100	N/A
UVM2	MC120	MAUV1	MP230	OFF	MEC120	MEUV4	MEP230	C
TFM2	MC120	MART1	MP230	OFF	MEC120	MERT4	MEP230	C
UVM3	MC120	MAUV1	MP230	ON	MEC120	MEUV4	MEP230	O
TFM3	MC120	MART1	MP230	ON	MEC120	MERT4	MEP230	O
UVM3H	MC120	MAUV1	MP230H	ON	MEC120	MEUV4	MEP230H	O
TFM3H	MC120	MART1	MP230H	ON	MEC120	MERT4	MEP230H	O
UVM5	MC120	MAUV1	MP560	ON	MEC120	MEUV4	MEP560	O
UVM6	MC120	MAUV1	MP560	See Note #2	MEC120	MEUV4	MEP560	C
- N/A — Not Applicable - Programmer Dipswitches apply to MP230H, and MP560 only. - Dipswitch #8 sets Recycle / Non-Recycle Operation. - MP560 Programmer Module has “Check-Run” Switch. - Note #1: For Standing Pilot, clip out red jumper on MP100. - Note #2: Dipswitch #8 - ON when red jumper of UVM6 is clipped.					- N/A — Not Applicable - Programmer Dipswitches apply to ME200, and ME500 Series Programmers - Dipswitch #6 sets Recycle / Non-Recycle Operation. (O = Non-Recycle, C = Recycle) - MEP500 Series Programmer Module has “Check-Run” Switch.			

PURGE	PTFI	M-Series II PROGRAMMER DIPSWITCH SETTINGS							MicroM PROGRAMMER DIPSWITCH SETTINGS		
TIME	TIME	#1	#2	#3	#4	#5	#6	#7	#1	#2	#4
7	5	ON	OFF	OFF	OFF	OFF	ON	OFF	C	C	C
7	5	OFF	ON	OFF	OFF	OFF	ON	OFF	C	C	C
30	5	OFF	OFF	ON	OFF	OFF	ON	OFF	O	C	C
7	10	OFF	ON	OFF	OFF	OFF	OFF	ON	C	C	O
90	5	OFF	OFF	ON	ON	OFF	ON	OFF	O	O	C
30	10	OFF	OFF	ON	OFF	OFF	OFF	ON	O	C	O
60	10	OFF	OFF	OFF	ON	OFF	OFF	ON	C	O	O
90	10	OFF	OFF	ON	ON	OFF	OFF	ON	O	O	O
- Dipswitches #1 through #5 set Purge Timing - Dipswitches #6 and #7 set TFI Timing									- Dipswitches #1 through #2 set Purge Timing - Dipswitch #4 sets TFI Timing		

M-SERIES TIMING CARDS	PURGE TIME	PTFI TIME
MT55	5	5
MT74	7	4
MT304	30	4
MT710	7	10
MT904	90	4
MT3010	30	10
MT6010	60	10
MT9010	90	10

65UV5 INTEGRATED FLAME SCANNER WITH INTERNAL FLAME RELAY

Bulletin CU-104

The 65UV5 flame scanner is a micro-processor based flame scanner that incorporates an internal single pole, single throw (normally open) flame relay with a fixed on/off threshold to provide flame on/flame off indication, eliminating the need of an external flame amplifier. The scanner utilizes an ultra-violet tube type sensor, and electromechanical self-checking shutter mechanism. The housing has a NEMA 4X / IP66 rating and is suitable for use in Class I Division II, Group A, B, C & D "hazardous environments". Models are available with a 4-second or a 1-second flame failure response time (FFRT).

The Fireye 65UV5 flame scanner is powered by 24 vdc and includes an integral 10-foot (3 meter) eight-conductor cable with cable gland. A two color internal LED indicates flame status (off/on) and alarm condition. This can be viewed through a viewing lens on the rear of the housing. The scanner provides an analog 4-20mA output for remote indication of flame signal strength.

Fireye 65UV5 self-checking scanners are used to detect ultraviolet emissions from fossil fuel flames such as natural gas, coke oven gas, propane, methane, butane, kerosene, light petroleum distillates and diesel fuels.



DIMENSIONS

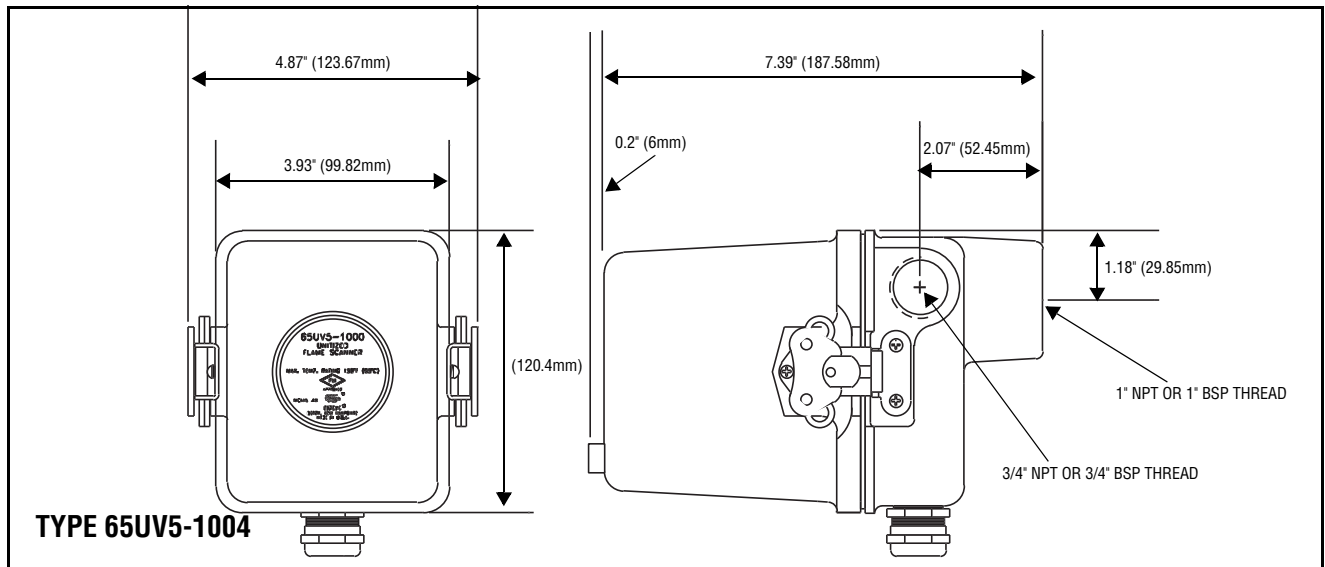

PART NUMBER	DESCRIPTION
65UV5-1004	Integrated Flame Scanner with 1" NPT mounting flange and 4 second FFRT, FM approved.
65UV5-1004E	Integrated Flame Scanner with 1" BSP mounting flange and 1 second FFRT, FM & CE approved.
65UV5-1004ECEX	Integrated flame scanner, 1 second FFRT, in Exd II c T6 hazardous area housing, ATEX approved (mounting flange ordered separately)
129-168-1	1"NPT mounting flange for 65UV5-1004ECEX
129-168-2	1"BSP mounting flange for 65UV5-1004ECEX

MB Series MULTI-BURNER CONTROL

Bulletin MB-6001



The Fireye Multi-Burner Monitoring System controls the start-up sequence and monitors the flame of up to 20 individual gas, oil, or combination gas/oil burners connected to a common valve train. Its dynamic on-board testing checks for faulty relays, proof of valve closure, high and low fire switch interlocks, and shorted air switch. Exclusive to the unit is its ability to specifically identify which burner caused the initial flame failure.

The Fireye Multi-Burner Control Monitoring System is a fully integrated control designed for the industrial process market (ovens and furnaces). It meets the operational requirements and safety standards pertaining to the industrial process market and offers many advantages over other systems.

The Fireye Multi-Burner Control System is complete with all functions built into one module, offering the opportunity to greatly reduce cost and space requirements normally required by other

non-integrated systems. Plug-in flame sensor modules that can sense UV, UV Self-Check and/or flame rod provide for easy replacement on an individual basis. Start up time is reduced through the use of on board DIP switches that allow quick configuration to meet application requirements.

The MB-600S, by itself, provides for 4 plug-in flame sensor modules. Expansion modules are available that can be easily attached to the MB-600S allowing for a system configuration up to 20 burners. Upon startup, the MB-600S interrogates the expansion modules to learn the number of flame sensor modules installed.

DIMENSIONS

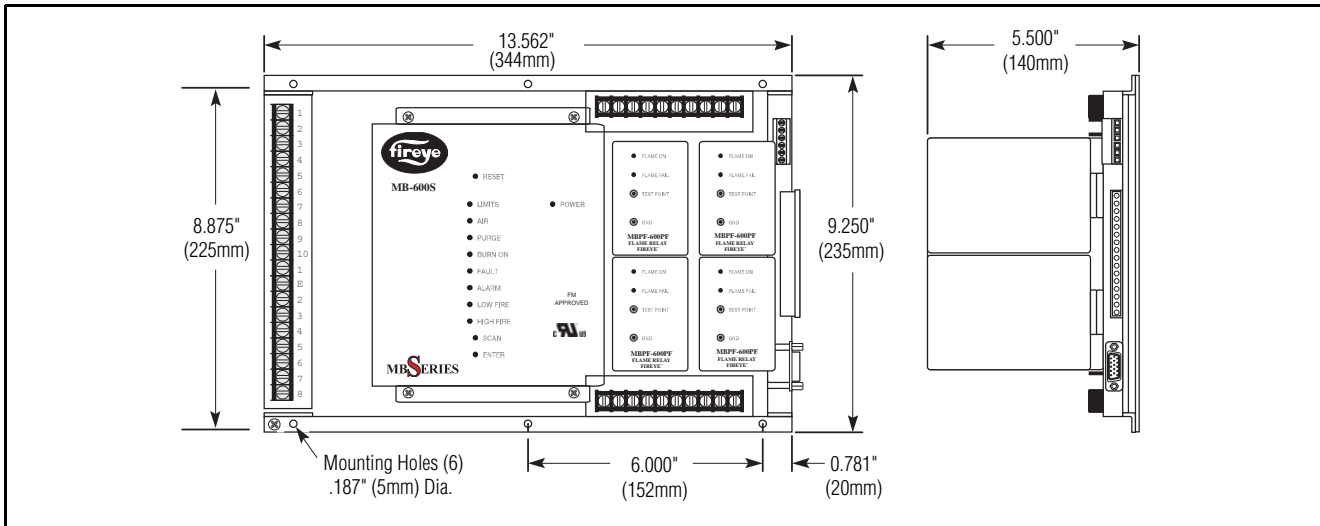

PART NUMBER	DESCRIPTION
MB-600S	Multi-Flame System, 120 VAC, 50/60 Hz consisting of motherboard (MB-600M), relay board (MB-600R), logic module (MB-600L), and power module (MB-600P), con-tains 4 aux inputs, purge modulation, valve leak testing
MB-632S	Same as MB-600S except motherboard is MB-632M for RS-232 communications.
MB-685S	Same as MB-600S except motherboard is MB-685M for RS-485 communications.
MB-604E	Expansion module for up to 4 additional burners
MB-608E	Expansion module for up to 8 additional burners
MB-600PF	Flame sensor module, UV/Self check UV, or FR with screw tabs for mounting on MB-600S multi-burner control system.

MB SERIES FLAME SENSOR MODULES

Bulletin MBPF-1001

The MBPF-100S, MB-600PF, MBPF-200S and MBPF-202S modules provide visual indication and electrical output that signal the user regarding flame presence in a combustion chamber. The module uses Fireeye optical ultra-violet scanners and/or flame rod to sense flame presence independently or as components in a burner management system. Many operational characteristics are provided including:

- UL recognized and FM approved-MBPF-100S, MB-600PF
- FM approved - MBPF-200S, MBPF-202S
- Self-contained: 120 VAC, 50/60: MBPF-100S, MB-600PF
- 220 VAC, 50/60: MBPF-200S, MBPF-202S
- UV detection or flame rod or both
- Flame ON LED
- User controlled Flame Fail LED
- Analog output test points permits direct reading of flame signal
- Uses standard 11-pin relay base
- Panel surface or DIN-rail mounting
- Remote testing of contacts available
- Self-check scanner available for MBPF-100S and MB-600PF

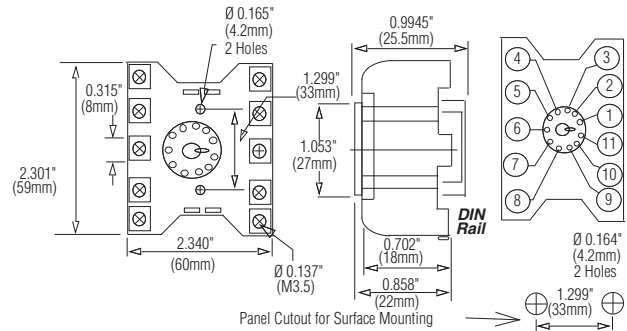
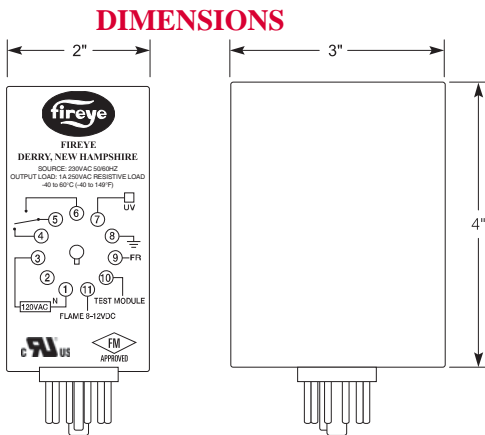

STYLE: 11 pin octal, snap-mount/surface mount
TERMINAL: M3.5 screws with captive wire clamp
WIRE SIZE: Maximum up to 2 - #12 AWG each terminal
ELECTRICAL RATING: 300V, 10A
 To secure MBPF to socket use retaining kit - P/N 129-172

PART NUMBER	DESCRIPTION
Flame Sensor	
MBPF-100S	Single channel module, 120VAC 50/60 Hz, use with UV detection or flame rod or both.
MB-600PF	Single channel module, 120VAC 50/60 Hz, use with UV detection or flame rod or both. Mounting ears provided for use with MB-600S multiburner programming module.
MBPF-200S	Single channel module, 220VAC 50/60 Hz, use with UV detection or flame rod or both.
MBPF-202S	Single channel module, 220VAC 50/60 Hz, use with UV detection or flame rod or both, 2 sec. FFRT.
Wiring Base	
60-2726	Socket, 11-pin, DIN rail or panel surface mounting.
129-172	Kit, retaining, secures module on socket, 60-2627.
Mounting Rails	
60-2539-12	DIN style mounting rail, 12 inches., mounts up to 4 modules.
60-2539-24	DIN style mounting rail, 24 inches., mounts up to 8 modules.
60-2539-36	DIN style mounting rail, 36 inches., mounts up to 12 modules.

PART NUMBER	DESCRIPTION
Scanners for use with MB Series	
UV7A4	Ultra-violet scanner, non-self check applications, 1/2" NPT mount, 4' lead with insulating coupling.
UV7A4W	Ultra-violet scanner, non-self check applications, NEMA 4, 1/2" NPT mount, 4' lead with insulating coupling.
UV7R4	Ultra-violet scanner, non-self check applications, 1/2" NPT, 90°, 6' lead with insulating coupling.
UV7SC	Ultraviolet scanner, self check applications, 120VAC, 1" NPT mount. (MBPF-100S only).
59-504-010	Cable/connector for self-check scanner, 10 foot.
Flame Rods	
69ND1-1000K4	Flame rod 1/2"NPT mount, 12" length.
69ND1-1000K6	Flame rod 1/2"NPT mount, 18" length.
69ND1-1000K8	Flame rod 1/2"NPT mount, 21" length.

Blank Page

FLAME SCANNERS AND APPLICATIONS

The following Fireeye flame scanners are used in conjunction with the appropriate Fireeye flame safeguard controls to provide reliable flame detection on a variety of burner applications and fuel types.

UV1A



Bulletin SC-102

Ultraviolet miniature non self-checking scanners. The UV1A is suitable for fuel gases and no. 2 oil. Non-replaceable tube. Mounting collar 1/2" NPT. Available with 3 ft. (UV1A3), 6 ft. (UV1A6), or 50 ft. (UV1A50) of tray-rated cable. Explosion proof housings are available.

UV90



Bulletin SC-102

Ultraviolet miniature non self-checking scanner suitable for frontal or side (90°) viewing. Complete with mounting fixture. Available with 3 ft. (UV90-3), 6 ft. (UV90-6), or 9 ft. (UV90-9) of flexible conduit.

UV2



Bulletin SC-103

Ultraviolet miniature non self-checking scanner. Similar in function to the UV1A3 but with a smaller mounting collar (3/8"). Non-replaceable tube.

UV8A



Bulletin SC-102

A 90° version of the UV1A6, but with unshielded leads and 0.70" diameter collar to be used with a 1/2" E.M.T. rain tight fitting (not furnished). The mounting collar is 1/2" NPT. Must be installed with metal shielding over the scanner leads.

45UV5-1005, -1006, -1007, -1009



Bulletin SC-103

Self-checking ultraviolet scanner is for continuously fired applications where recycling is infrequent or absent. The self-checking circuit checks the electronics and the UV tube for proper operation every four seconds during the firing period. Suitable for fuel gases and oil. Replaceable UV tube and (4-314-1) shutter mechanism (61-2914-1). Mounting 1" NPT or BSP pipe thread with 6 ft. (1.8m) lead wires. Must be installed with metal shielding over the scanner leads. Explosion-proof housings are available for models 45UV5-1005, 45UV5-1007, and 45UV5-1009.

45UV3-1050

A rugged diecast housing that mounts on 3/4 inch pipe with setscrew. Vertical mounting of UV tube provides greater sensitivity. UV tube is replaceable (4-314-1). Scanner is non self-checking. 4 ft (1200mm) lead wires. Must be installed with metal shielding over this canner leads.

Bulletin SC-103



55UV5-1007, -1009

Self-checking ultraviolet scanner is for continuously fired applications where recycling is infrequent or absent. Similar in function to the 45UV5 but suitable for use in Class I, Div. 2, Groups A, B, C, D and Class II, Div. 2, Groups F and G hazardous areas. Rated NEMA 4X, IP66. Replaceable UV tube (4-314-1), and shutter mechanism (61-7075-1). Mounting 1" NPT or BSP pipe thread with 20 ft (6M) of five conductor cable.

Bulletin SC-106



69ND1

Flame rod for gas flames only. The flame rod is an inexpensive reliable gas flame detector. Mounting 1/2" male NPT. 12" (304mm), 18" (475mm), and 24" (609mm) available.

Bulletin SC-103



48PT2



Lead sulfide infrared scanner is designed to detect low frequency IR signals from gas or oil flames. Mounting collar is 1/2" NPT with straight or 90° mounts (shown). Available with 4 ft (121.9m) or 8 ft (243.8m) flexible conduit. Replaceable 4-263-1 sensor cell.



Bulletin SC-103

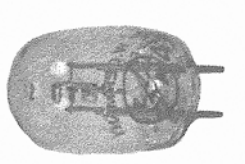
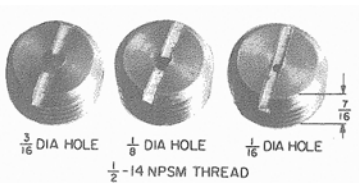
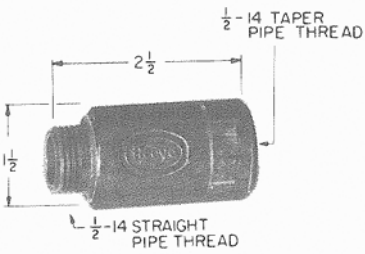
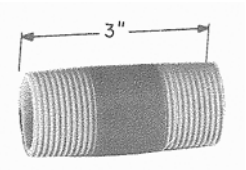

PART NUMBER	DESCRIPTION	USE WITH	BULLETIN
Ultraviolet Scanners			
UV1A-1-CEX	ATEX Exd IIC T6 explosion-proof housing with UV1A scanner.	Flame -Monitor, FlameWorx, MB, C-Series, D-Series, M-Series, M-II Series, MicroM Series with non-self check amplifier.	SC-102
UV1A3	¹ / ₂ " NPT Connector, 3 ft. (914mm) tray-rated cable. Non self-checking.		
UV1A6	¹ / ₂ " NPT Connector, 6 ft. (1828mm) tray-rated cable. Non self-checking.		
UV1A50	¹ / ₂ " NPT Connector, 50 ft. tray-rated cable. Non self-checking.		
UV2	³ / ₈ " NPT Connector, 3 ft. (914mm) tray-rated cable. Non self-checking.		
UV8A	¹ / ₂ " NPT 90° head, 6 ft. wire, no cable. Non self-checking.		
UV90-3	UV non-self check scanner for frontal or side (90°) viewing. Complete with mounting fixture and 3 ft. (900mm) flex conduit.		
UV90-6	UV non-self check scanner for frontal or side (90°) viewing. Complete with mounting fixture and 6 ft. (1800mm) flex conduit.		
UV90-9	UV non-self check scanner for frontal or side (90°) viewing. Complete with mounting fixture and 9 ft. (2700mm) flex conduit.		
45UV3-1050	UV Scanner, ³ / ₄ " sleeve/set screw mounting. Non self-checking.		
45UV5-1005	UV self-check scanner 1 inch NPT threads. 25VDC shutter circuit.	25RU8-4580, 25SU5-4018 or 61-5745-3 shutter drive module	SC-101
45UV5-1105	Same as -1005 but British threads.	25RU8-4580, 25SU5-4018 or 61-5745-3 shutter drive module	SC-101
45UV5-1006	UV self-check scanner. Use with self-check amplifier only, 1 inch NPT threads.	D-Series, 72DUVS1 only	SC-101
45UV5-1007	UV self-check scanner. Use with self-check amplifier. 1 inch British threads, 120-230 VAC shutter.	Flame-Monitor, C-Series, D-Series, MicroM Series with self-check amplifier.	SC-101
45UV5-1007CEX	ATEX Exd IIC T6 explosion proof housing with 45UV5-1007 scanner.		
45UV5-1009	UV self-check scanner. Use with self-check amplifier. 1 inch NPT threads, 120-230 VAC shutter.		
45UV-1009CEX	ATEX Exd IIC T6 explosion proof housing with 45UV5-1009 scanner.		
45UV5-1009EX	Explosion proof 45UV5-1009. Class I, Div. 1 and 2, Groups C and D. Class 2 Div. 1 and 2, Groups E, F, G.		
Infrared Scanners			
48PT2-CEX	ATEX Exd IIC T6 explosion proof housing with 48PT2 scanner	Flame-Monitor, C-Series, D-Series, MicroM Series with infrared amplifier.	SC-103
48PT2-1003	IR Scanner, 8 ft. (2400mm) tray-rated cable, straight head		
48PT2-1007	IR Scanner, 4 foot (1200mm) tray-rated cable, straight head		
48PT2-9003	48PT2-1003, 8 ft. tray-rated cable with 90° head		
48PT2-9007	48PT2-1007, 4 ft. tray-rated cable with 90° head		
69ND1-1000K4	Flame Rod 12 inches ¹ / ₂ " mount	Flame -Monitor, FlameWorx, MB, C-Series, D-Series, M-Series, M-II Series, MicroM Series with flame rectification amplifier.	SC-103
69ND1-1000K6	Flame Rod 18 inches ¹ / ₂ " mount		
69ND1-1000K8	Flame Rod 24 inches ¹ / ₂ " mount		

ACCESSORIES FOR FIREYE PRODUCTS

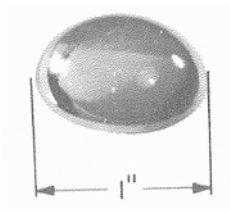
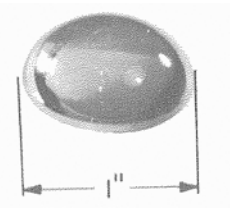
<p>4-263-1</p>  <p>Firetron Cell for 48PT2 Infrared Scanner. C-Series, D-Series and Flame-Monitor.</p>	<p>4-314-1</p>  <p>Ultraviolet Tube for use in 45UV5-1005, -1009, 45UV2, 45UV3-1050, C-Series, D-Series and Flame-Monitor controls.</p>	<p>10-88</p>  <p>Set of 3 Orifice Plugs. Drilled 1/16", 1/8", 3/16", 1/2". Pipe Thread. Also available: 10-15, Blank orifice plug for drilling to any size required. For use with UV1A Scanner</p>
<p>35-69</p>  <p>Heat Insulator. Reduces conduction of heat from sight pipe to scanner. Used with 48PT1, 48PT2, UV-1A. 1/2" pipe connection.</p>	<p>35-127-1 (NPT) 35-127-3 (BSP)</p>  <p>Heating insulating nipples (Epoxyglass) for use with 45UV2, 45UV5. 1-inch pipe size, male both ends. Used to reduce conduction of heat from scanner mount to scanner.</p>	<p>38-96</p>  <p>Flame Meter, 2 1/4" square, 4-20ma</p>

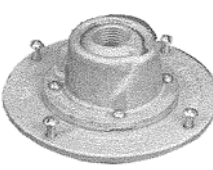
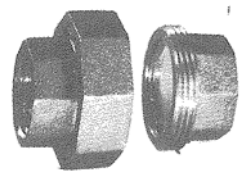
<p>38-97</p>  <p>Flame-Monitor E100 Mounting Screw</p>	<p>46-38</p>  <p>Quartz Lens for use in 45UV5-1005, -1006, -1007, 1008, and -1009 scanners.</p>	<p>46-56</p>  <p>Quartz Lens. Used with 45UV3 to increase scanner sensitivity. Replaces quartz window in scanner.</p>
<p>48-1805 Flame-Monitor E100 Mounting Screw</p>  <p>48-1836 Flame-Monitor E110 Mounting Screw</p> 	<p>60-302</p>  <p>Swivel Mounting Adapter. Simplifies scanner sighting. Used with 48PT1, 48PT2 and UV1A. 1/2" pipe connection.</p>	<p>60-801</p>  <p>Sealing union with pyrex window. Seals scanner sight pipe against excessive fire-box pressure. Used with 48PT1, 48PT2, 1/2" pipe connection.</p>

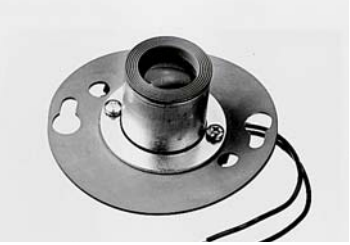
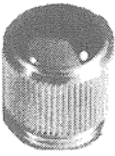
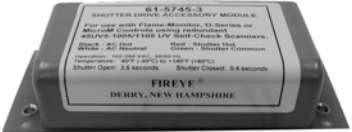
<p>60-1199-1,2</p>  <p>Sealing coupling with quartz window. Seals scanner sight pipe against excessive firebox pressure. 1" pipe thread. Used with 45UV1, 45UV2, 45UV3, 45UV5. 60-1199-1 (NPT), 60-1199-2 (BSP)</p>	<p>60-1257, 60-1290</p>  <p>Sealing union with quartz window (60-1257). 60-1290 has quartz lens to increase scanner sensitivity. For use with UV1A/UV1B scanners.</p>	<p>60-1664-3 (NPT) 60-1664-4 (BSP)</p>  <p>Scanner swivel mount for use with 45UV2, 45UV3, 45UV5. Simplifies scanner sighting.</p>
<p>61-2914-1</p> 	<p>61-3263-1</p>  <p>Shutter, Bracket, and Lens Assembly for 45UV5-1005 thru -1009.</p>	<p>61-436</p>  <p>Lens Cap (standard). Replacement for all 48PT1 and 48PT2 models.</p>
<p>61-5745-3</p>  <p>External shutter drive circuit board for dual 45UV5-1005 scanners.</p>	<p>82-95</p>  <p>Lens holder for 45UV2, 45UV5 and 45RM1/2</p>	

CROSS REFERENCE TABLE

Notes are referenced at the end of the table.

OBSOLETE TYPE AND MODEL	NOTES	CURRENT MODEL COMBINATIONS			
		CONTROL	DISPLAY	PROGRAMMER	AMPLIFIER
24CJ5-3000	1, 2, 3, 4	E110	ED510	EP380	ERT1
24CJ5-3010	1, 2, 3, 4				
24CJ5-3011	1, 2, 3, 4				
24CJ5-5010	2, 3, 4, 26				
25CJ5-5011	2, 3, 4, 26	E110	ED510	EP390	ERT1
24CJ5-5015	2, 4	E110	ED510	EP380	ERT1
24RJ8-1000	1, 2, 4				
25CU6-1050	1, 2, 3, 4	E110	ED510	EP380	EUV1
25CU6-1062	1, 2, 3, 4, 26				
25CU6-5062	2, 3, 4, 26				
25CU6-1063	1, 2, 3, 4, 26	E110	ED510	EP390	EUV1
25CU6-5063	2, 3, 4, 26				
25CU6-5065	2, 4	E110	ED510	EP160	EUV1
25CU6-5066	2, 4	E110	ED510	EP260	EUV1
25CU6-RS-2	1, 2, 3, 4	E110	ED510	EP380	EUV1
25CU6-RS-2D	1, 2, 3, 4				
25CU6-RS-2RE	2, 3, 4	E110	ED510	EP390	EUV1
25DU4-1040	1, 2, 6	70D40	—	—	72DUV1
25DU4-5040	2, 6				
25DU4-5060	2				
25RU8-4580	27	E110	ED510	EP160	EUVS4
25RU8-6558	7	E110	ED510	EP260	EUVS4
25RU8-6560	7				
25RU8-6566	1, 4, 7, 8	E110	ED510	EP260	EUV1
25RU8-6570	7	E110	ED510	EP160	EUV1
25RU8-6580	1, 4, 7, 9	E110	ED510	EP160	EUV1
25SU5-1000	10, 11, 12	25SU5-5011 or 25SU5-5012	60-2205 (Optional)	—	INC.
25SU5-1011	10, 11, 12				
25SU5-4011	11, 12				
25SU5-4111	11, 12				
25SU5-4013	13	70D40	—	—	72DUVS4
25SU5-4018	13				
26DF4-5030	2	70D40	—	—	72D1R1
26CF6-1000	1, 2, 3, 4	E110	ED510	EP380	E1R1
26CF6-1010	1, 2, 3, 4				
26CF6-5020	2, 3, 4, 26				
26CF6-1011	1, 2, 3, 4	E110	ED510	EP390	E1R1
26CF6-5021	2, 3, 4, 26				
26CF6-5022	2, 4	E110	ED510	EP160	E1R1
26CF6-5022(A)	2, 4				

OBSOLETE TYPE AND MODEL	NOTES	CURRENT MODEL COMBINATIONS			
		CONTROL	DISPLAY	PROGRAMMER	AMPLIFIER
26CF6-5023	2, 4	E110	ED510	EP260	E1R1
26CF6-RC-3A	1, 2, 3, 4				
26RJ8-CB-1	14	E110	ED510	EP260	E1R1
26RJ8-CB-3	14	E110	ED510	EP160	E1R1
26RJ8-1000	14, 15, 16	E110	ED510	EP260	E1R1
26RJ8-1001	14, 15, 16				
26RJ8-1002	14, 15, 16				
26RJ8-1003	14, 15, 16				
26RJ8-1004	14, 15, 16				
26RJ8-1006	14, 15, 16				
26RJ8-1008	14, 15, 16				
26RJ8-1011	14, 15, 16				
26RJ8-1012	14, 15, 16, 17				
26RJ8-1016	14, 15, 16, 17				
26RJ8-1018	14, 15, 16, 17				
26RJ8-6008	14, 15, 16, 17				
26RJ8-6012	14, 15, 16, 17				
26RJ8-6016	14, 15, 16, 17				
26RJ8-6018	14, 15, 16				
26RJ8-1005	15, 18	E110	ED510	EP160	E1R1
26RJ8-1009	15, 18, 19				
26RJ8-6009	15, 18, 19				
26RJ8-1114	CONSULT FACTORY				
26RJ8-1115	CONSULT FACTORY				
26RJ8-5914	CONSULT FACTORY				
26RJ8-6026	7, 18, 22	E110	ED510	EP260	E1R1
26RJ8-6058	14	E110	ED510	EP260	E1R1
26RJ8-6060					
26RJ8-6066					
26RJ8-6068					
26RJ8-6160D					
26RJ8-6070	14	E110	ED510	EP160	E1R1
26RJ8-6080D	14	E110	ED510	EP160	E1R1
26SJ5-1000	14, 15, 20	70D40	—	—	72D1R1
26SJ5-1102					
26SJ5-5900T					
26SJ5-5901T					
26SJ5-5903					
26SJ5-6000					
26SJ5-6002					
26SJ5-1150	14, 15, 20, 21	70D40	—	—	72D1R1 or 72DRT1
26SJ5-1152					
26SJ5-6052					
26SJ5-6152					

OBSOLETE TYPE AND MODEL	NOTES	CURRENT MODEL COMBINATIONS			
		CONTROL	DISPLAY	PROGRAMMER	AMPLIFIER
26SJ5-5910	CONSULT FACTORY				
29RF5-1000	14, 15	E110	ED510	EP260	E1R1
29RF5-1001	14, 15				
29RF5-1002	14, 15				
29RF5-1005	14, 15				
29RF5-1009	14, 15				
29RF5-1015	14, 15				
29RF5-1103	14, 15				
29RF5-6009	14, 15				
29RF5-6015	14, 15				
29RF5-6103	14, 15				
TFM1D	25				
TFM1F	25	MEC120	—	MEP100	MERT4
TFM2	23, 25	MEC120	—	MEP230	MERT4
TFM2-A7	23				
TFM2-A30	23				
TFM2-A90	23				
TFM3	23, 25				
TFM3-7	23				
TFM3-90	23				
TFM3H	23, 25	MEC120	—	MEP230H	MERT4
UVM2	23, 25	MEC120	—	MEP230	MEUV4
UVM2-A	23, 25				
UVM2-A7	23, 25				
UVM2-A30	23, 25				
UVM2-A90	23, 25				
UVM1	23, 25	MEC120	—	MEP100	MEUV1
UVM1D	23, 25				
UVM1F	25				
UVM1G	25				

NOTES FOR CROSS REFERENCE TABLE

1. Requires new wiring base 60-1466-2 or 60-1386-2.
2. Re-use existing scanner.
3. Add timer if terminal 10 is used for open damper (30 seconds I.C.T.O).
4. Make earth ground connection.
5. E110 requires terminal 13 to be powered on call for heat. If there is no fuel valve end switch, make sure terminal 13 is powered from terminal 3.
6. Refer to bulletin C-500 for starting circuit change.
7. Replace scanner.
8. Check ignition timing and select appropriate programmer (EP261 if Terminal 5 is used).
9. Check if early spark termination is used, select appropriate programmer with same function.
10. Requires new scanner with UV Self-check (45UV5-1000) and a 6-conductor scanner cable (59-470).
11. Hard-wire new wiring base 60-2206-1.
12. Use 25SU5-5012 in multi-burner applications.
13. Re-use existing scanner (45UV5-1005) if 61-5745-3 Shutter Drive Module is used. Otherwise replace scanner with 45UV5-1009.
14. Evaluate condition of existing wiring base and scanner. If it is appropriate, then hard-wire in a new base and replace the entire scanner assembly.
15. Check the operating voltage of the existing system. The new control is only available in 120VAC.
16. Evaluate modulating circuit, rewire as required.
17. Evaluate dual scanner application. If possible, use one scanner (D-Series will not work with dual scanners).
18. Supply new wiring base (60-1386-2 or 60-1466-2) and new scanner and rewire.
19. Special for Babcock and Wilcox, original drawings need to be evaluated and updated as required.
20. If terminals 5 and 6 are used, refer to Bulletin PD-4 page 2, note 2 for instructions to add external relay and use of 51CQ1 start push-button.
21. Determine if a flame rod is being used and select an appropriate amplifier. If both a flame rod and an IR scanner are used, either one or the other must be disconnected or a second control and amplifier must be supplied.
22. Refer to SN #47 to add relay for circulating fan motor.
23. Refer to Bulletin C-4000 for appropriate dipswitch settings.
24. The original UVM-1 control was supplied with a 24V (T and T) connection. If the low voltage circuit is used, then supply a transformer relay. A new wiring base is required.
25. All M-Series controls are interchangeable without wiring changes except UVM1 and UVM2A.
26. If the fuel valve end switch is not present, jumper terminals 3 to 13.
27. Refer to Service Note #65.

GENERAL REFERENCE TABLES

NEMA Standard Classification Codes for Flame Safety Control Enclosures

- NEMA 1— General Purpose. For indoor protection, where conditions are not unusually severe.
 NEMA 2— Driptight. Designed to exclude falling moisture or dirt. Particularly applicable to cooling rooms, laundries, etc., where condensation is prevalent. For indoor use.
 NEMA 3— Weather Resistant (weatherproof). For outdoor use; designed to withstand all normal exposure to natural elements. Controls mounted on pullout racks for easy access. With rain hood and weather seals.
 NEMA 4 — Watertight. Withstands water pressure from 1 inch hose nozzle, 65 gallons per minute, from distance of not less than 10 feet for five minutes. Suitable for maritime applications, breweries, etc.
 NEMA 5 — Dust-tight. Equipped with dust-tight gaskets. Suitable for mills and other high-dust atmospheres.
 NEMA 6 — Submersible. For submerged operation under specified pressures and time.
 NEMA 7— Hazardous Locations, National Electrical Code Class I (circuit breaks in air).
 NEMA 8 — Hazardous Locations, National Electrical Code Class I (circuit breaks immersed in oil).
 NEMA 9 — Hazardous Locations, National Electrical Code Class 2.
 NEMA 10 — Explosion-proof. Meets U.S. Bureau of Mines requirements for explosive atmospheres.
 NEMA 11 — Acid or Fume Resistant. Provides for immersion of enclosed equipment in oil.
 NEMA 12 — Industrial Use. Excludes oils, dust, moisture, to satisfy individual requirements.

POWER AND HEAT	
1 BTU	776 ft.-lb.
1 cal	0.003968 BTU Watt/hr.
1 BTU	0.293 Watt 4.2 cal/min.
1 Watt	3,413 BTU/hr
1 Watt-hr.	3.413 BTU/hr
1 kW (1000 Watts)	3413 BTU/hr
1 kW/hr.	3413 BTU/hr
1 hp	0.746 BTU 33,000 ft.-lb./min.
1 bhp	9.809 kW 33,479 BTU/hr 34.5 lb. of steam per hour.

BTU CONTENT OF FUELS		
Grade or Type	Unit	BTU
No. 1 Oil	Gallon	137,400
No. 2 Oil	Gallon	139,600
No. 3 Oil	Gallon	141,800
No. 4 Oil	Gallon	145,100
No. 5 Oil	Gallon	148,800
No. 6 Oil	Gallon	152,400
Natural Gas	cu ft.	950 to 1,150
Propane	cu ft	2,550
Butane	cu ft.	3,200

Conversion to Symmetric Units

Quantity	Standard Unit	SI Unit	SI Symbol	Multiplier to Convert from Standard Unit to SI Unit
Temperature	Degrees Fahrenheit	Degrees Celsius	C	5/9 (F-32)
Length	Inches/Feet	Millimeters/meters	mm/m	25.4/0.3048
Capacity—Gas Valves	Cubic feet per hour	Cubic meters per hour	m ³ /hr	0.0283168
Control Valve Coefficient	C _v a	k _v b	k _v	0.857
Fluid Capacity	Gallons per hour	Liters per second		0.001052
Heat	BTU per cubic foot	Megajoules per cubic meters	MJm ³	0.0671
Pressure Drop	Inch of water column	Kilopascals	kPa	0.2486
Pressure	Inch of mercury	Kilopascals	kPa	3.3741
Pressure	Pounds per square inch	Kilopascals	kPa	6.8948
Power (electric)	Horsepower	Watts/kilowatts	W/kW	746/0.746
Weight	Pounds	Kilograms	kg	0.4536

Conversion Factors for Boiler Ratings

1. Boiler Horsepower
2. 33,475 BTU's per hour (output)
3. 34.5 lbs. steam per hour (from and at 210° F to 100° C.
4. 9810.6 watt (output)
5. 1 lb. steam per hour
970 BTU's per hour (output)
(from 212° F or 100° C)
6. 284.3 watts (output)

Boiler Horsepower	Pounds Steam Per Hour	BTU/Hour (Output)	Megawatts Output
20	690	660,500	.20
40	1,380	1,339,000	.39
60	2,070	2,008,500	.59
80	2,760	2,678,000	.78
100	3,450	3,347,500	.98
150	5,200	5,021,250	1.47
200	6,900	6,695,000	1.96
250	8,600	8,368,750	2.45
300	10,500	10,042,500	2.94

Electric Motors Rating

Approximate Horsepower	120V		240 V	
	Full Load	Locked Rotor	Full Load	Locked Rotor
1/6 ac dc	4.4 —	26.4 —	2.2 —	13.2 —
1/4 ac dc	5.8 3.1	34.8 31.0	2.9 1.6	17.4 16.0
1/3 ac dc	7.2 4.1	43.2 41.0	3.6 2.0	21.6 20.0
1/2 ac dc	9.8 5.4	58.8 54.0	4.9 2.7	29.4 27.0
3/4 ac dc	13.8 7.6	82.8 76.0	6.9 3.8	41.4 38.0
1 ac dc	16.0 9.5	96.0 95.0	8.0 4.7	48.0 47.0
1 1/2 ac dc	20.0 9.5	120.0 95.0	10.0 4.7	60.0 47.0
2 ac dc	24.0 17.0	144.0 170.0	12.0 8.5	72.0 85.0
3 ac dc	34.0 25.0	204.0 250.0	17.0 12.2	102.0 122.0

Units of Pressure

KNOWN PRESSURE UNIT	REQUIRED PRESSURE UNIT								
	Kilopascals	Pounds per Sq. Inch	Ounces per Sq. Inch	Millimeters of Mercury	Kilograms Sq. Inch	Inches of Water	Inches of Mercury	Feet of Water	Centimeters of Water
Centimeters of Water	0.0981	0.0142	0.227	0.735	0.000999	0.394	0.0289	0.0328	-
Feet of Water	2.99	0.433	6.94	22.4	0.0305	12.0	0.883	-	30.5
Inches of Mercury	0.249	0.0361	0.578	1.87	0.00254	-	0.0735	0.0833	2.54
Inches of Water	98.1	0.0361	0.578	735.0	-	394.0	29.0	32.8	1000.0
Kilograms/sq. inch	0.133	0.0193	0.308	-	0.00136	0.535	0.0394	0.0446	1.36
Millimeters of Mercury	0.133	0.0193	0.308	-	0.00136	0.535	0.0394	0.0446	1.36
Ounces/sq. inch	0.431	0.0625	-	-8.24	0.00439	1.73	0.128	0.144	4.40
Pounds/sq. inch	6.89	-	16.0	51.7	0.0703	27.7	2.04	2.31	70.4
Kilopascals	-	0.145	2.32	7.52	0.010	4.02	0.295	0.334	10.2

LITERATURE LIST FOR FIREYE PRODUCTS

PART NUMBER	DESCRIPTION
BD-5001	BLV512, BLL510 display modules for use with BurnerLogiX
BL-1001	YB110/YB230 Fireye® BurnerLogiX™
BLZ-1001	ZB110/ZB230 Fireye® BurnerLogiX™
BLZPTS-1	Pressure and temperature sensors for the BurnerLogiX
CG-14	Domestic Price Sheet
CG-14X	Export Price Sheet
CP-47	Test Unit for Flame Monitor, C and D Series
C-4000	Modular M-Series II
C-4001	Programmer Modules M-Series II
C-4002	Amplifier Modules M-Series II
C-90	Test Unit for M-Series, M-II, MicroM
CU-104	65UV5 Flame Scanner
D-4041	D-Series Controls 70D40/70D41
E-1101	FLAME-MONITOR™ E110
E-1201	FLAME-MONITOR™ E120, 220 VAC
E-2101	E210/E211 FLAME-MONITOR™
E-3001	E300 Expansion Module
E-3201	E320 Expansion Module
E-8001	ED400, ED600, ED150, ED550 Accessories
E-8002	ED610, ED512, ED580 Accessories
EC-4851	RS232/RS485/ Converter
ED510-DATA	ED510 2 page color
ED-5101	ED510 Technical Bulletin
EAMP1	E1R1, EUV1, ERT1, EUVS4 Amplifier
EP-1601	EP160, EP161, EP165, EP170 Programmer
EP-2601	EP260, EP261, EP265, EP270 Programmers
EP-3801	EP380, EP381, EP382, EP390 Programmers
EP160-DATA	EP160 Programmer Modules. 2-page color
EP260-DATA	EP260 Programmer Modules. 2-page color
EP380-DATA	EP380 Programmer Modules. 2-page color
EPD-1601	EPD160, EPD261, EPD270 Programmer Modules
EPD-2601	EPD260, EPD261, EPD270 Programmer Modules
EPD-3801	EPD380, EPD381, EPD382, EPD390 Programmer Modules
F-101	Training School Brochure
F-103	Literature Fax Sheet
FM-10	Flame Monitor Promotional Brochure
INT-1000	inTouch Wireless Monitoring System Manual
MAMP-1	MicroM Amplifiers
MB-6001	Fireye Multi-Burner Control

PART NUMBER	DESCRIPTION
MBPF-1001	MBPF-100S, 200S, 202S, MB-600PF Sensor Modules
MC-5000	MicroM Controller-Installation Manual
MOPT1	MicroM Plug-In Option Boards
MP-5201	MicroM Programmer Modules
MM-2	Modernization Adapter 60-1765
MTS-1	M-Series II Trouble Shooting Guide
NEX-6101	NEXUS NX6100 Integrated Burner Control System
PPC-6001	PPC6000 fuel air ratio controller
PPC-4001	NEXUS PPC4000 fuel air ratio controller
NEX-3004	Nexus FX04 series 4 Nm servo motor for PPC4000
NEX-3020	Nexus FX20 series 20 Nm servo motor for PPC4000
NEX-3050	Nexus FX50 series 50 Nm servo motor for PPC4000
NXCESO2-1001	Oxygen Probe for PPC4000
133-750	O2 mounting flange installation instructions
NXD-4101	NXD410 user interface
NXCESVFD-1001	VFD plug-in board for PPC4000
SC-101	45UV5-1005, through -1009 Self-checking Scanners
SC-102	UV1A6, UV8A, UV90 Ultraviolet Scanners
SC-103	45UV2, 45UV3, 48PT1, 48PT2, 45CM1, 69ND1 Scanners
SC-107	UV Non Self-Checking Scanner Models:UV7A4, UV7R4 UV & Self-Check Scanner Model:UV7SC
SN-100	Earth Grounding Methods for M-Series II
TSD-1041	TSD Touch Screen Displays for BurnerLogiX control
YBT-1000	57YB4 Tester for BurnerLogiX YB110 controls
YP-1000	YP Programmers for BurnerLogiX control
YZEM-3001	YZ300 / YZ320 Interlock Annunciator for BurnerLogiX control
133-675	129-178-x Remote Display Mounting Kit
133-676	60-2810-1 Pigtail Wiring Base for BurnerLogiX YB control
133-677	60-2812-1 / 60-2814-1 Wiring Bases for BurnerLogiX YB control
133-701	60-2850-1 Pigtail Wiring Base for BurnerLogiX ZB control
133-702	60-2852-1 / 60-2854-1 Wiring Bases for BurnerLogiX ZB control

HOW TO IDENTIFY FIREYE CONTROLS

Beginning January 1976 Fireye adopted the US national standard date coding for all units whereby the first two digits identify the year and the second two digits identify the week of the year. Example 9212—twelfth week of 1992.

“M” Series Controls

UVM, TFM Controls have their date code stamped on the side of the chassis.

M-II Series and MicroM Series Controls

Both the M-II and MicroM Series Controls have the model number printed on a label located on the chassis, amplifier and programmer. The date code, serial number and engineering codes are printed on a label on the chassis. The date code and engineering code are stamped on the underside of the printed circuit board on the programmer and amplifiers.

“D” Series Controls

D-Series Chassis Controls (70D10/, 70D20/21, 70D30 & 70D40/41) have date code, engineering code, and model number stamped on the control. Model number appears on chassis board under top end of the chassis and on a label on the black plastic rear cover of the chassis. D-Series Amplifiers and Programmers have their model numbers in the lower right hand corner as you look at the covered side. Their date code is just opposite the model number but on the uncovered side of the circuit board.

Flame-Monitor Controls

Flame-Monitor Chassis (EB700, EB720, EB721) have the model number, date code, and engineering code stamped on the bottom of the chassis. Flame-Monitor Amplifiers and programmers have their model number printed on a label located on the upper left hand corner tab. Their date code and engineering code appear on the uncovered side of the printed circuit board.

BurnerLogiX Controls

BurnerLogiX Chassis' (YB, ZB) and Interlock Annunciators (YZ), have their model number, date code, and engineering code printed on a label located on the left side of the product. The BurnerLogiX Programmer Modules (YP) have the date code ink-stamped on the top surface of the product. The BurnerLogiX Display Modules (BLL, BLV) have the date code ink-stamped on their pc boards, next to the RJ45 ribbon cable connector.

“C” Series Controls

Types 24CJ5, 25CU6, 25DU4, 26CF6 have chassis labels located on the top of the amplifier that identify the control as to type and model. The code and serial numbers appear stamped on left side of control and stamped on front of the control just above or below the timer motor. The serial number for “C” Series controls is coded as follows: “72B” indicates February 1972 unit, “71D” indicates April 1971 unit.

PPC4000 Controls

PPC4000 Control has a barcode label located on the top of its cover that contains the model number, date code, engineering code, and serial number. The date code is the first four digits of the six-digit group. In the following example, the date code is 1135: 01-PPC4000-113504-0171.

Factory Trade-In

The following Fireye control models are acceptable as trade-in toward the purchase of any applicable Fireye control at trade-in pricing from an Authorized Primeline Distributor. (Refer to the current price sheet CG-14 for part numbers with trade-in pricing):

C-Series, P-Series, M-Series, M-Series II (Chassis and Programmers only), D-Series (Chassis, Programmer, Amplifier), Flame-Monitor (Chassis, Programmer, Amplifier), an BurnerLogiX. Used Honeywell controls are also accepted towards trade-in purchase of Fireye controls.

The only requirement is that the Honeywell control be of the same type functionally as the desired new Fireye control. Check with your local Fireye sales office for further details.

IMPORTANT NOTICE

When replacing Honeywell controls with Fireye controls, be sure to follow the wiring diagram included with the Fireye unit. Fireye and Honeywell controls are not directly interchangeable, external wiring requirements are different.

FIREYE TERMS AND CONDITIONS OF SALE

AGREEMENT BETWEEN FIREYE (FIREYE) AND THE PURCHASER INCLUDING, BUT NOT LIMITED TO, ALL NEGOTIATIONS, ORDERS, ACCEPTANCES, SALES AND DELIVERIES. NO TERM OR CONDITION OR OTHER UNDERSTANDING, ORAL OR WRITTEN, IN ANY WAY PROPOSING TO VARY OR EXPAND UPON THESE TERMS AND CONDITIONS, WHETHER CONTAINED IN THE PURCHASER'S FORMS OR ELSEWHERE, SHALL BE BINDING ON FIREYE, ITS SUCCESSORS OR ASSIGNS, UNLESS IN WRITING AND SIGNED BY AN OFFICER OF FIREYE.

1. WARRANTIES, EXCLUSIVE REMEDIES, AND LIMITATION OF DAMAGES: Fireye guarantees for one year from the date of installation or 18 months from the date of manufacture to replace, or at its option, to repair any product or part thereof which Fireye, in its sole discretion, deems to be defective in material or workmanship or which otherwise fails to conform to the description of the product on the face of its sales order. Fireye's obligations pursuant to this warranty do not extend to any products or parts thereof which Fireye determines to have been installed, operated, maintained, repaired, or altered improperly or otherwise than in conformity to Fireye's applicable instructions, or which have been subject to misuse, accident or neglect.

THE FOREGOING IS IN LIEU OF ALL OTHER WARRANTIES, BOTH EXPRESS AND IMPLIED, INCLUDING THE WARRANTIES OF MERCHANTABILITY AND FITNESS FOR A PARTICULAR PURPOSE.

EXCEPT AS SPECIFICALLY STATED IN THESE TERMS AND CONDITIONS OF SALE, REMEDIES WITH RESPECT TO ANY PRODUCT OR PART MANUFACTURED OR SOLD BY FIREYE, OR WITH RESPECT TO ANY BREACH OF OR DEFAULT UNDER THIS CONTRACT (INCLUDING ANY BREACH OF WARRANTY), SHALL BE LIMITED EXCLUSIVELY TO THE RIGHT TO REPLACEMENT OR REPAIR F.O.B. FIREYE MAIN WAREHOUSE LOCATION, AS ABOVE PROVIDED. IN NO EVENT SHALL FIREYE BE LIABLE FOR CONSEQUENTIAL OR SPECIAL DAMAGES OF ANY NATURE WHICH MAY ARISE IN CONNECTION WITH SUCH PRODUCT OR PART OR ANY BREACH OF OR DEFAULT UNDER THIS CONTRACT. TO THE EXTENT PERMITTED BY LAW, THE AGGREGATE LIABILITY OF SELLER HEREUNDER WHETHER IN CONTRACT, TORT (INCLUDING NEGLIGENCE) OR OTHERWISE, WILL BE LIMITED TO ONE TIMES THE CONTRACT VALUE, PROVIDED HOWEVER THE FOREGOING LIMITATION DOES NOT LIMIT THE LIABILITY OF SELLER FOR ANY INJURY TO, OR DEATH OF A PERSON, CAUSED BY THE GROSS NEGLIGENCE OF SELLER.

2. ACCEPTANCE OF ORDERS: Fireye shall have no obligation, nor shall Fireye be bound, with respect to any order, unless the order has been accepted by an authorized employee of Fireye. At its discretion, Fireye may elect to reject any orders submitted by Purchaser.

3. SHIPMENT: All prices are F.O.B. Fireye main warehouse location. Method and route of shipment are at Fireye's discretion, unless the Purchaser supplies explicit instructions on the face of the sales order in which case the Purchaser shall pay any additional transportation costs occasioned by such instructions. Purchaser assumes all risk of loss or damage to the products during shipment and is responsible for insuring such products for their purchase price.

4. DELIVERY AND FORCE MAJEURE: Under no circumstances shall Fireye be liable for any loss, damage or delay due to any cause beyond its reasonable control, including but not limited to acts of government, strikes, lockouts, other labor disputes, fire, explosion, theft, weather damage, flood, earthquake, riot, civil commotion, war, malicious mischief or act of God.

5. TAXES: The amount of any present or future sales, revenue, excise or other taxes applicable to the products listed herein shall be added to the purchase price and shall be paid by the Purchaser, or in lieu thereof the Purchaser shall provide Fireye with a tax exemption certificate acceptable to relevant taxing authorities.

6. QUOTATIONS AND PRICES: Prices are subject to change without notice and orders calling for future delivery will be billed according to the price in effect at the time of delivery. A \$100.00 net minimum billing applies to all orders. Written quotations are effective only if made on Fireye's standard quotation form and, in any event, such quotations shall automatically expire sixty (60) calendar days from the date issued and are subject to earlier termination by notice at any time during that 60-day period. Payment terms are as stated on the invoice or net thirty days when not specified.

7. CANCELLATIONS, MODIFICATIONS AND RETURNS: Once placed, orders may be cancelled or modified by the Purchaser only with the written consent of Fireye in its sole discretion. If such consent is given and an order is cancelled or modified, the Purchaser shall reimburse Fireye for all expenses (as determined by Fireye in its sole discretion) incurred prior to such cancellation or as a result of such modification and pay such cancellation fee as Fireye may determine in its sole discretion.

Goods may be returned only with the prior written authorization of Fireye and shall be subject to such fees and restocking charge as may be determined by Fireye, in its sole discretion. All goods returned pursuant to Fireye's authorization

shall be returned without damage.

8. PATENT INFRINGEMENT: If suit is brought against Purchaser alleging that the manufacture or sale of products sold hereunder infringes any United States patent (except infringement occurring as a result of incorporating a design or modification of the goods at Purchaser's request, or occurring as a result of Purchaser's failure to use the goods in the manner directed and exclusively for the purposes for which they are sold), then Fireye will defend, indemnify and hold harmless Purchaser and pay any awards against Purchaser arising from such infringement; provided, however, that Purchaser has given Fireye (a) prompt written notice of any charge of such infringement, (b) the right at its expense to settle such charge or to defend or control the defense of any suit based upon such charge, and (c) all necessary information and assistance in connection therewith. In case any product sold hereunder is held to infringe an existing patent and the use of said product is enjoined. Fireye shall have the option of either procuring for the Purchaser the right to continue using said product, or replacing the same with a non-infringing product, or modifying the same so as to avoid infringement, or removing the same and refunding the purchase price. THIS PARAGRAPH SETS FORTH FIREYE'S SOLE AND EXCLUSIVE LIABILITY WITH RESPECT TO PATENT INFRINGEMENT.

9. TRADEMARKS AND TRADE NAMES: Purchaser acknowledges that all brand names, trade names and trademarks incorporated onto or associated with the products (collectively, the Marks) purchased hereunder are the exclusive property of Fireye and that the Purchaser will not acquire any rights in any of the Marks by purchasing the products hereunder. Purchaser shall not make any use of the Marks at any time except as otherwise authorized in writing by Fireye.

10. PROPRIETARY INFORMATION/NONDISCLOSURE: Purchaser acknowledges that any knowledge or information, including drawings and data, which Fireye may have disclosed or may hereafter disclose to the Purchaser incident to the placing and filling of this order, shall, at all times, remain the exclusive property of Fireye, and Purchaser shall acquire no interest in, or right with respect to, such proprietary information unless otherwise stated in writing by Fireye. Purchaser further acknowledges that such proprietary information constitutes valuable, special and unique business assets of Fireye and Purchaser will not now or at any time in the future use any such information in any manner or disclose any such information to any person or entity, except as expressly permitted in writing by Fireye.

11. DEFAULT/REMEDIES AND TERMINATION: In the event that Purchaser fails to make payment when due for goods shipped to it or otherwise breaches any provision of this Contract, Purchaser shall be liable for any loss suffered by Fireye by reason of such action including by not limited to, costs of collection, attorneys' fees, loss of Fireye's profits, and additional freight, storage and handling costs. In such event, Fireye, at its sole discretion, may also terminate this Contract, require that any shipment be made C.O.D., demand cash in advance prior to filling any orders from the Purchaser and place the Purchaser on credit hold. The above-listed remedies are cumulative and in addition to any other remedies available to Fireye at law or in equity.

12. INDEMNIFICATION: Purchaser shall indemnify, defend and hold harmless Fireye from and against any and all claims, losses, liabilities and expenses (including without limitation, attorneys' fees) on account of any injuries or deaths of any persons or damage to any property arising from the sale and use of goods sold by the Purchaser in which the products sold hereunder are incorporated.

13. DISPUTE RESOLUTION: Any disputes arising under this Contract shall be referred to binding arbitration in Boston, Massachusetts under the commercial arbitration rules of the American Arbitration Association.

14. GOVERNING LAW: This Contract shall be governed and interpreted in accordance with the laws of the State of New Hampshire. The state courts of New Hampshire and the U.S. District Court for the District of New Hampshire shall have exclusive jurisdiction with respect to claims made hereunder.

15. NON-WAIVER: Failure by either party to exercise any of its rights under this Contract upon one occasion shall not constitute a waiver of its right to exercise the same or other rights on another occasion.

16. ASSIGNMENTS: Purchaser may not assign or transfer any of its rights or duties under this Contract without the written consent of Fireye. Fireye may, in its sole discretion, assign or transfer any or all of its rights or duties under this Contract to any person or entity, including without limitation any affiliate of successor.

17. SEVERABILITY: In the event any provision herein should be held unenforceable by a court of competent jurisdiction, such court is hereby authorized to amend such provision so that it will be enforceable to the fullest extent permitted by law, and all remaining provisions shall continue in full force without being affected, impaired or invalidated thereby in any way.

FIREYE DISTRICT SALES OFFICES

UNITED STATES SALES OFFICES

Boston / New York Area

720 Putnam Pike
Suite 801
Smithfield, RI 02828
(401) 309-2392

Cleveland Area

9800 Rockside Rd.
Valley View, OH 44125
(216) 533-4779
FAX: (860) 660-8862

Columbus Area

3792 Mountview Rd.
Columbus, OH 43220
(614) 203-7086

Minnesota Area

2914 Pennsylvania Avenue, South
St. Louis Park, MN 55426
(952) 926-3088
FAX: (952) 926-3374

Philadelphia Area

42 Reads Way
Suite 111
New Castle, DE 19720
(302) 323-8122
FAX: (302) 323-8105

Phoenix Area

14989 West Windsor Ave.
Goodyear, AZ 85395
(623) 236-8521
FAX: 623-236-8592

Sacramento Area

715 Poplar Court
Live Oak, CA 95953
(916) 979-7017
FAX: (530) 695-2067

Tulsa Area

2600 North 10th Street
Broken Arrow, OK 74012
(918) 355-8865
FAX: (918) 355-8874

Combustion Efficiency Products

20820 NE Morgan Circle
Brush Prairie, WA 98606
(360) 624-1791
FAX: (360) 892-5767

CANADIAN SALES OFFICES

Montreal

452 rue Bourque, Suite 900A
Repentigny, QC, J5Z 5A2
Canada
(450) 585-8897
FAX: (450)657-8898

INTERNATIONAL SALES OFFICES

Europe

c/o Kidde Graviner
Poyle Road
Colnbrook, Slough
Berkshire, UK SL3 OHB
44-1753-766363
FAX: 44-1753-684540

Latin America

Kidde de México, S.A. de C.V.
Av. Insurgentes Sur No.1685, Piso 14
Col. Guadalupe Inn, C.P. 01020
México, D.F.
52-55-5677-5146
FAX: 52-55-5677-5146

So. Africa

Fireye Inc.
23 Whitehouse Avenue
Farrarmere, Benoni
1501
Gauteng
South Africa
27 11 0251614
FAX. 27 86 6772001

Belgium

Troonstraat 37 bus 0401
Oostende, Belgium B-8400
32 472 864 278

Russia

Fireye Inc.
Varshavskoje Shossee
d.1, str. 1-2, off A 405
Moscow 117105
Russia
495-269-7401 x116
FAX: 495-269-7402 x134

Singapore

70 Bendemeer Road
#02-02, Luzerne Building
Singapore 339340
(65) 6424-7963
FAX: (65) 6424-7978

China

15F, Hankou Road, No 300,
Jie Fang Building,
Shanghai, China, 200001
86 21 6331 1225
FAX: 86 135 6410 1786

Distributed by:



888.858.3647 | relevantsolutions.com