

TF1 TOTAL FILTER

A high performance in-line system filter, which uses hydrocyclonic and magnetic action to remove all types of contaminants from central heating system water.

- Unique action, removes magnetic & non-magnetic contaminants
- Dosing point for Fernox 'F' range products
- All valves and fittings included
- Hydrocyclonic and magnetic in-line filter
- Fits vertical and horizontal pipework
- Cleaned in minutes without removal or disassembly
- Will not block or restrict flow
- Complies with company guidance for carbon footprint reduction and sustainability ethos
- As with all magnetic products, if you have an implanted cardiac device extra caution should be taken at all times when handling any Fernox TF1 filter



Product Specifications

- Maximum operating temperature: 212°F
- Maximum operating pressure: 43.5 psi
- Maximum flow rate: 13.2 gallons/min
- Magnetic characteristics: 9000 Gauss Neodymium magnet assembly
- Body material: Glass fibre reinforced nylon plastic

Dimensions and weight

- Height: 11.34"
- Width: 6.18"
- Depth: 4.29"



TF1 Total Filter

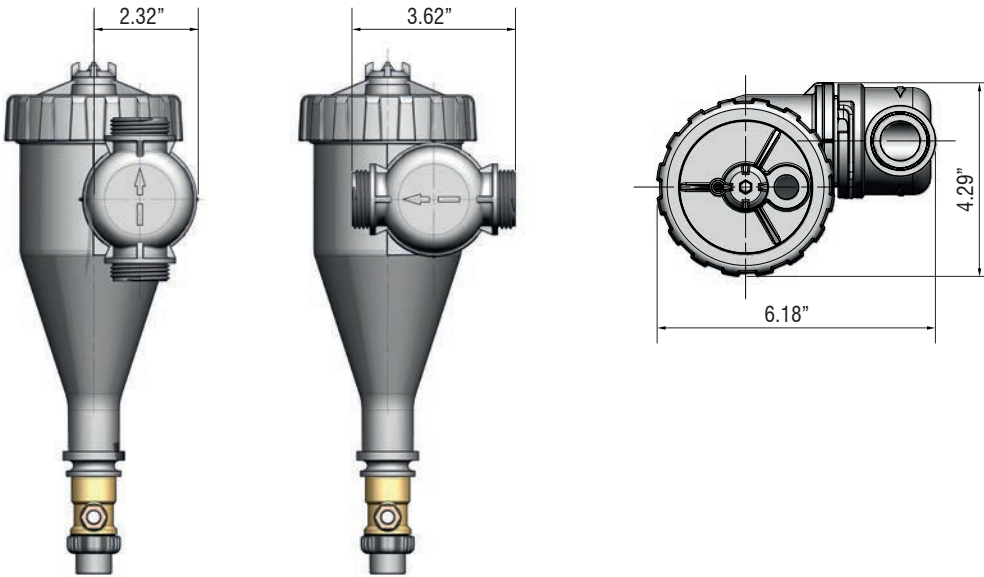

Cleaning Guide



1. Close inlet and outlet valves

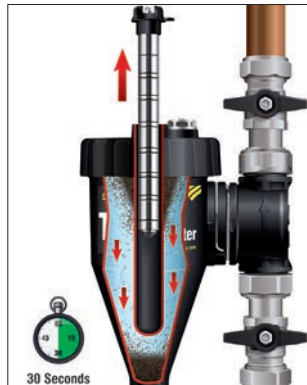

2. Remove magnet



3. Open outlet and drain valves



4. Close drain valve, replace magnet and open inlet valve

Inlet/Outlet Orientation Guide



1. Using a flat end screwdriver in the recess shown, gently lever the locking clip into the 'unlock' position.



2. Pull the inlet/outlet port approximately 3 mm away from the body to allow rotation to the required position.



3. Push the inlet/outlet port back towards the body of the unit to prevent further rotation.



4. Push the locking clip securely back into the 'lock' position.

Dosing Guide

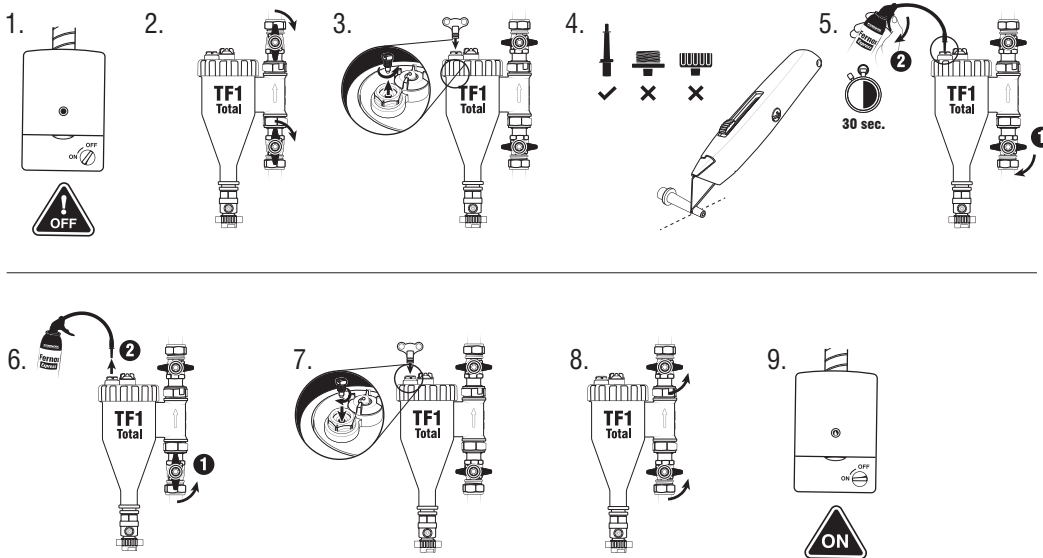

Easy dosing of Fernox Express products via a TF1 Filter with a slip socket connection.

Note: If the filter contains magnetite or sludge, flush it clean with water before dosing. Refer to the cleaning guide instructions.

Pressure Loss Data

The graph (right) shows the pressure loss in kPa over the TF1 Total Filter under different flow rates. An average domestic central heating system flow rate of 3.3 gal./m (0.005 gals./s) would result in a pressure drop over the TF1 Total Filter of 1.0kPa or 0.145psi or 0.01 bar.

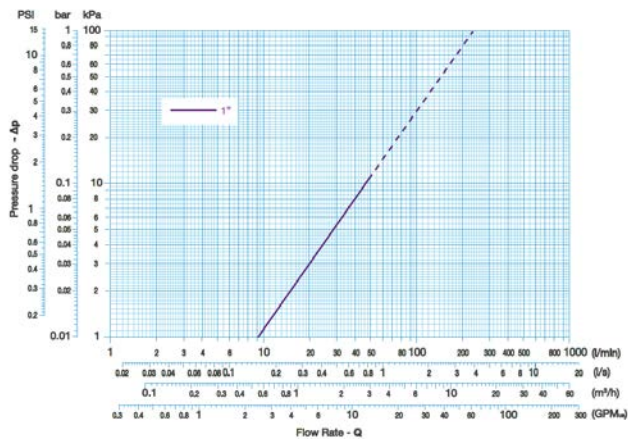

Application

The Fernox TF1 Total Filter can be connected directly on to the pipework using the valve fittings provided. The Fernox TF1 Total Filter is supplied ready to install into vertical pipework with system water flowing upwards. Further installation instructions are provided with the unit. The TF1 Total Filter can be installed in any one of 24 separate orientations enabled by its unique inlet/outlet mechanism, to allow the flow to be in any direction as it passes through the unit.

Product uses

The Fernox TF1 Total Filter (UK patent granted No. 2448232) is a revolutionary in-line filter, which combines hydrocyclonic action with specially designed magnet assemblies, to remove both magnetic and non-magnetic contaminants from system water and contain safely within the filter before removal.

Product Codes

TF1 Total Filter 1" Sweat Valve - 60003

Packaging, Handling and Storage

Individually packaged with all valves and detailed instructions included. No special storage requirements needed.