

- ACCESSORIES -

• A1 FAN CONNECTION (Line Voltage Control Only)	KB Duct Thermostat for Step Controller
A2 Terminal Blocks (Standard)	KC 0-10V Interface Standard thru 10 Steps
• B1 FAN CONTROL RELAY	KD 4-20 Milliamp Standard thru 10 Steps
B2 Pilot Relay	KE 135 Ohm Interface Standard thru 10 Steps
B3 Mercury Contactors	
B5 Back-Up Contactors or Safety Contactors (Disconnecting All Lines)	L1 SCR Controls (Furnished and Factory Wired)
B6 Disconnecting Contactors	L2 SCR Controls (Furnished by Others Factory Wired)
• B7 FAN INTERLOCK RELAY (Specify Interlock Voltage)	L3 Transducer
	LA Wall Thermostat for SCR Control (Standard)
• C1 AIR PRESSURE SWITCH	LB Duct Thermostat for SCR Control
C2 Time Delay Between Steps (Non-Adjustable)	LC 0-10V Interface for SCR Control - Field Calibrated
CA Time Delay Between Steps (Adjustable)	LD 4-20 Milliamp Interface for SCR Control
C3 Pilot Switch (De-Energize All Contactors)	LE 135 Ohm Interface for SCR Control
C4 Pilot Switch (De-Energize Each Step)	
C5 P.E. Switches (Furnished and Factory Wired)	LL Full SCR
C6 P.E. Switches (Furnished by Others Factory Wired)	M1 Derated Elements (Specify Watt/Density Required)
C7 P.E. Switches - Load Carrying (Furnished and Factory Wired)	M2 80/20 Nickel Chrome Element
• D1 TRANSFORMER CLASS II	N1 Stainless Steel Element Connections
• D2 D2 TRANSFORMER WITH PRIMARY FUSING	N4 Nema 4 Enclosure
D3 D3 Replaceable Fuse for Option D1 or D2	Q1 Insulated Control Panel
E1 E1 Manual Reset High Limit	Q2 Hinged Lid (Std. With Fuses, Door Disconnect, Manual Reset)
E5 E5 Remote Manual Reset	Q3 Panel Lock and Keys
• F1 F1 CIRCUIT FUSING PER U.L. AND N.E.C.	Q4 Allow for 1" Duct Insulation
F2 F2 One Fuse Block Per Step (For Heaters Less Than 48 Amps)	Q5 Allow for 1/2" Duct Insulation
F3 F3 One Fuse Block Per Heater (For Heaters Less Than 48 Amps)	Q6 Allow for 2" Duct Insulation
G1 G1 Pilot Light (Control Circuit On)	Q7 Allow for 1.5" Duct Insulation
G2 G2 Pilot Light (Each Step is On)	R1 Aluminized Steel Construction
G3 G3 Pilot Light (Thermal Cut Out is Open)	R2 Stainless Steel Construction
G4 G4 Pilot Light (Air Switch is Open)	S1 Single Point Terminal Block (Fusing if Required)
G5 Pilot Light (Power On)	V1 Remote Control Panel (size varies with control options)
G6 Pilot Light (Fan On)	V2 Flanged Mount
HZ 50 HZ	V3 Unequal KW Per Steps
J1 Door-Interlock Disconnect Switch (Fused)	V4 Recessed Terminal Box (Specified Depth Required)
J2 Door-Interlock Disconnect Switch (Non-Fused)	V5 Dust Tight Panel
J3 Circuit Breakers	V6 Protective Screen - Air Entering Side (Std. Over 48")
J6 Panel Mount Disconnect Switch (52 Amps Max.)	V7 Round Duct Connection Accessory (Specified size required)
K1 Step Controller	V8 Bottom Mount - U.L. Listed
KA Wall Thermostat for Step Controller (Standard)	V9 Rain Tight Panel

1. AT LEAST ONE OF THE ACCESSORIES MARKED WITH (*) IS NECESSARY TO MEET U.L. REQUIREMENTS.
2. U.L. AND N.E.C. REQUIRE CIRCUIT FUSING FOR EACH HEATER OVER 48 AMPS.
3. SPECIFY IF HEATER REQUIRES U.L. LABEL.
4. Specify KW per step if steps are not equal.
5. Heaters will be sized for unlined ducts unless otherwise specified.
6. Control panel will be offset to the left of the element section (Position 1) when airflow is in a left to right direction unless otherwise specified.
7. When specifying RP models select heater section(s) the same as CBK models. Terminal blocks and air pressure switch (if specified) are contained in the heater section(s). All other components are contained in the coordinated remote control panel(s) and disconnecting contactors (B6) are required.
8. All heaters over 50 KW and higher, 4 steps and higher, require time delay relays (C2 or CA) between steps with the following exceptions:
 1. Heaters with step controllers (K1) or SCR controls (L1) installed by Warren.
 2. Written confirmation (CF) from customer that Warren approved control device will be installed in field.

HORIZONTAL MOUNTING POSITIONS

P1

AIR FLOW RIGHT
PANEL LEFT

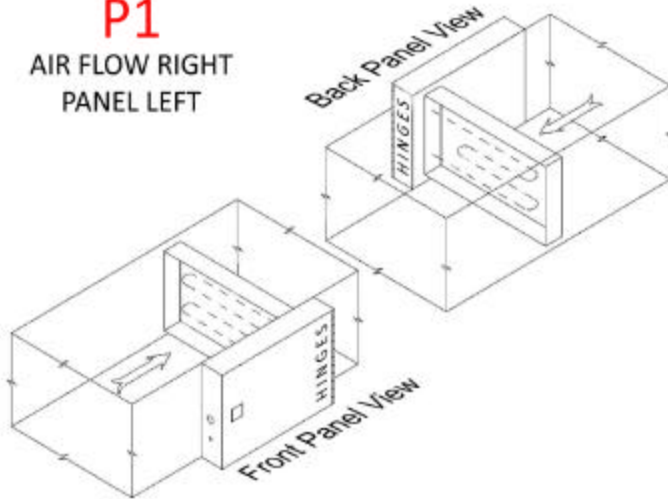

P2

AIR FLOW LEFT
PANEL LEFT

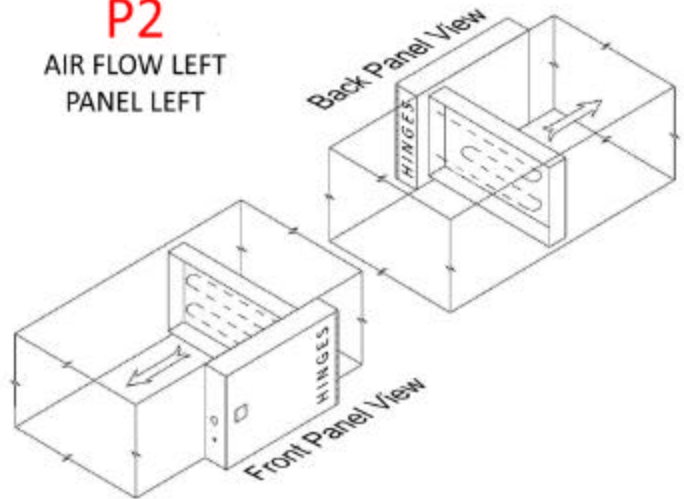

P3

AIR FLOW RIGHT
PANEL RIGHT

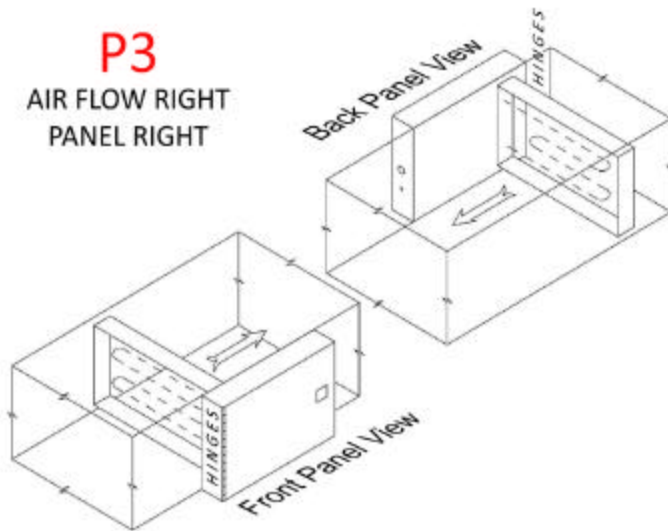

P4

AIR FLOW LEFT
PANEL RIGHT

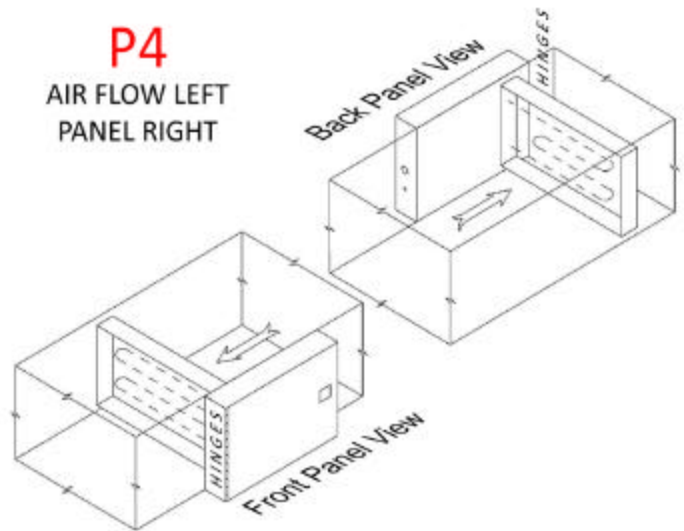

P9

BOTTOM MOUNT

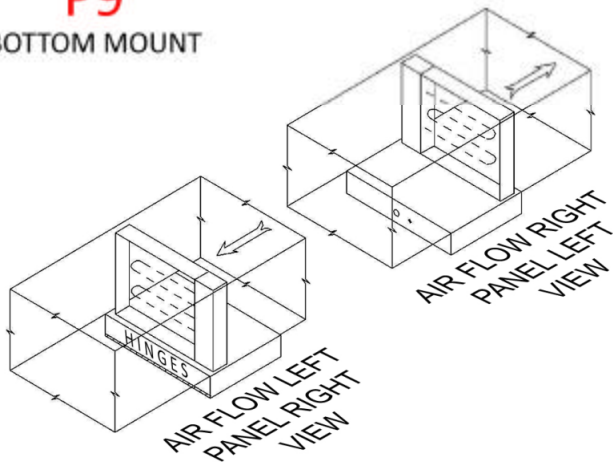

P10

BOTTOM MOUNT

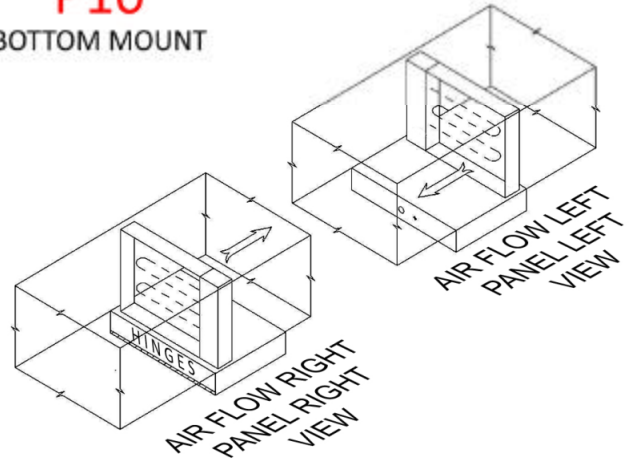

VERTICAL MOUNTING POSITIONS

P5

AIR FLOW DOWN
PANEL DOWN

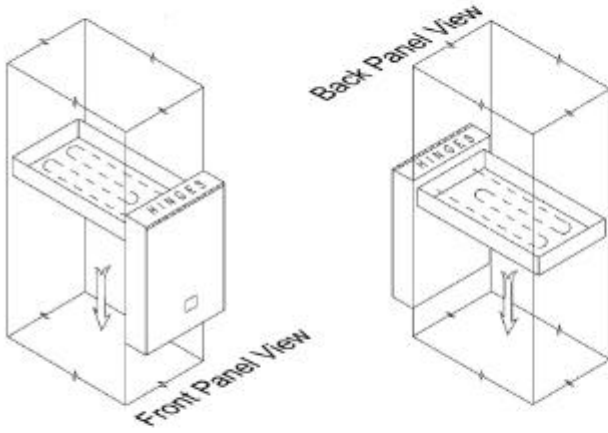

P6

AIR FLOW UP
PANEL DOWN

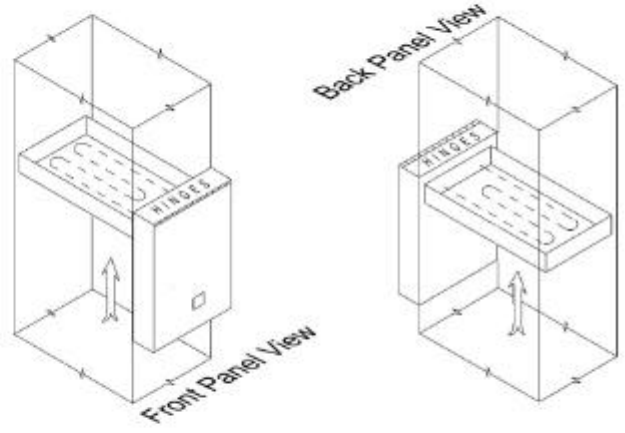

P7

AIR FLOW DOWN
PANEL UP

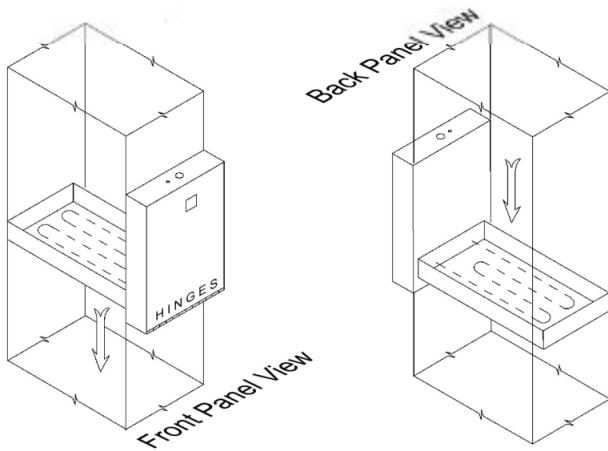

P8

AIR FLOW UP
PANEL UP

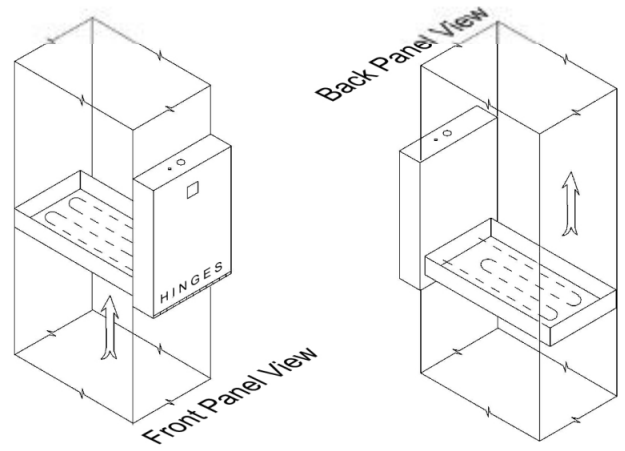

MODULAR DUCT HEATER DIMENSIONS

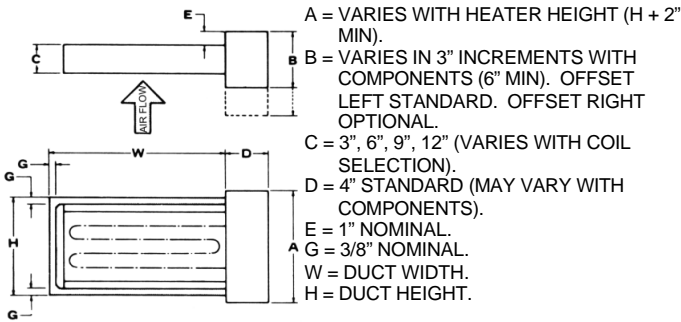

SLIP-IN MODELS CBK & RP HEATER SECTION

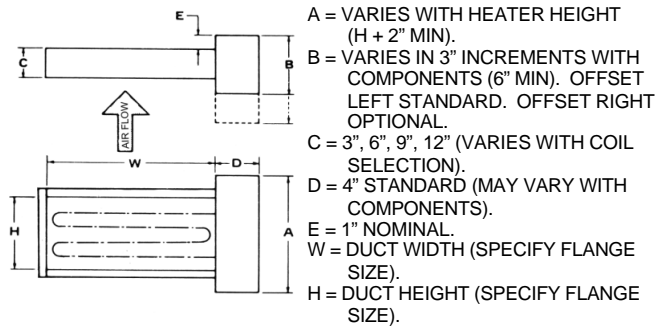

FLANGED MOUNT MODELS CBK & RP HEATER SECTION

WARREN MODULAR ELECTRIC DUCT HEATERS CUSTOM BUILT MODELS

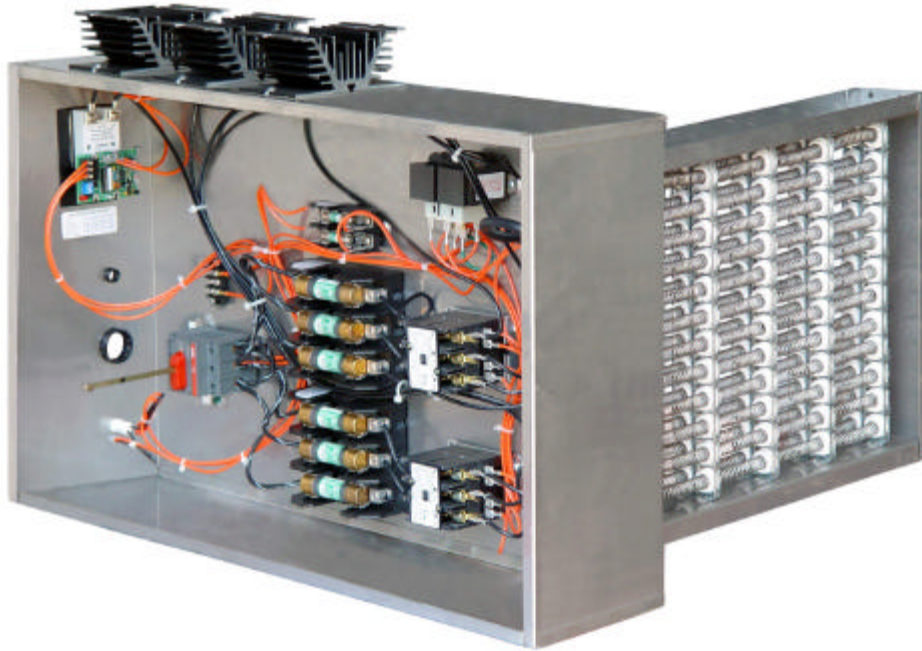

MODEL CBK INTEGRAL PANEL SLIP- IN MOUNT

- The Warren Modular Duct Heater offers the most modern engineering design, with maximum versatility and dependability.
- Elements are computer selected by the calculated wire temperature method to insure that exact electrical and heat characteristics are achieved.
- The element support ceramics are held by the unique element support rack permitting them to expand without cracking or breaking.
- The computer selected elements always utilize every necessary ceramic element support insuring that the elements evenly fill the open area of every duct.
- Virtually unlimited KW capacities and element size combinations insure that any requirements can be met.
- Multiple airflow positions are available assuring maximum position flexibility.
- Heaters for all voltages can be provided.
- Heaters are U.L. listed zero clearance and meet all applicable requirements of The National Electric Code (N.E.C.).
- Heater frames and boxes are constructed of 20 gauge or heavier galvanized steel.
- A hinged control panel cover for all units with fuses, door disconnects, or manual limits is standard.
- Disconnecting magnetic contactors are standard on all heaters.
- Heaters are available as Slip-In or Flanged Mount.
- Factory pre-wiring of accessory components eliminates costly field installation.
- A specific wiring diagram is furnished for every heater regardless of the accessories.
- A broad range of control options and accessories is offered to meet all needs and allows true customizing of heater requirements.
- Completely serviceable without removal from the installation.

CUSTOM BUILT MODELS

REMOTE PANEL (V1)

- Control Section can be mounted in any convenient location.
- Connections between Control Panel and Heater section are easily made through the use of factory installed terminals.
- Heater Section available as Slip-In or Flanged Mount.
- All construction features of the Custom Built Heaters are incorporated in the Remote Panel Heater.
- Disconnecting contactors meet UL requirements for remote location.
- Control Panel components are completely factory wired and only the connections made between the panel and the heater need to be field connected.
- All accessories available for Custom Built Heaters are available for Remote Panel Heaters.

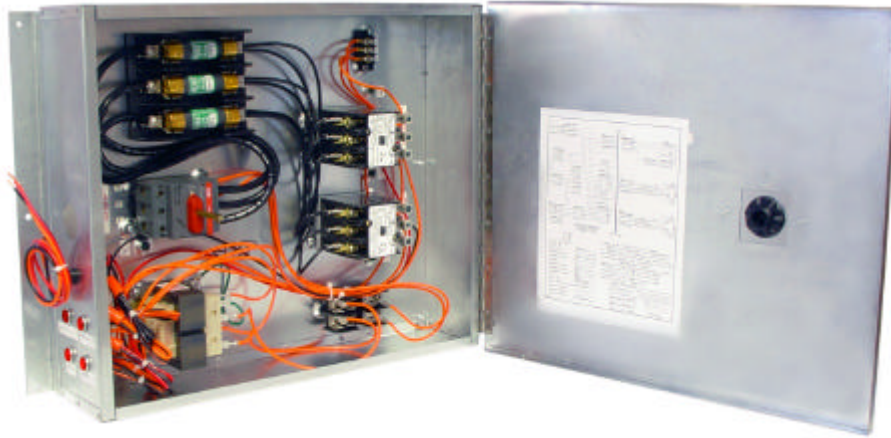

BOTTOM MOUNT (V8)

- UL Listed as Bottom Mount Heater.
- Controls are accessible without the need to remove the heater.
- Factory pre-wiring of accessory components eliminates costly field installation.
- Provides maximum ease of serviceability in limited installation space.
- All construction features of the Custom Built Heater are incorporated in the Bottom Mount Heater.

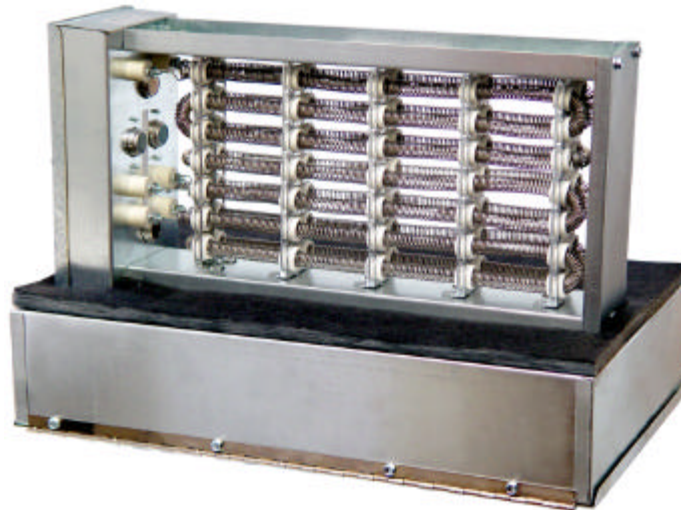

FLANGED MOUNT (V2)

- Flanged Mount provides maximum duct rigidity.
- Standard 1" flange matches standard SMACNA duct flange.
- Heater flange and boxes are constructed of 20 gauge or heavier galvanized steel.
- Design allows virtually unlimited duct size match-ups.
- Deeper flange depth available where required.
- With required information regarding exact blower configuration, and with proper air baffle, flange mount heaters can be close-coupled to blower units.

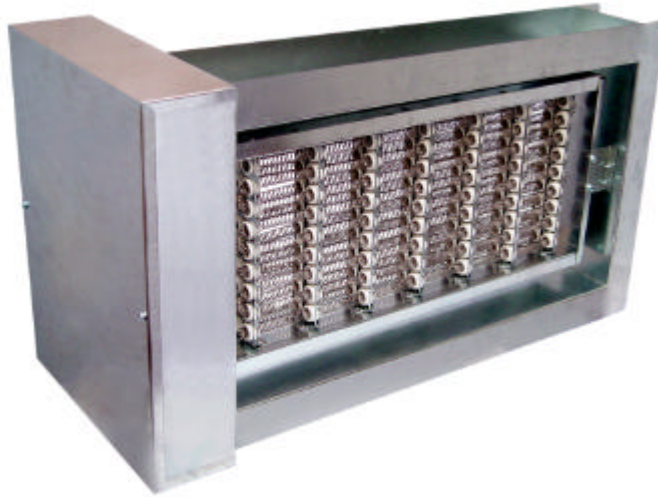

ROUND DUCT (V7)

- Allows an easy method of installing an electric duct heater in a round sheet metal duct.
- The Electric heater section comes factory installed in an adapter section with appropriately sized round pipe connections provided at the inlet and outlet for field connection.

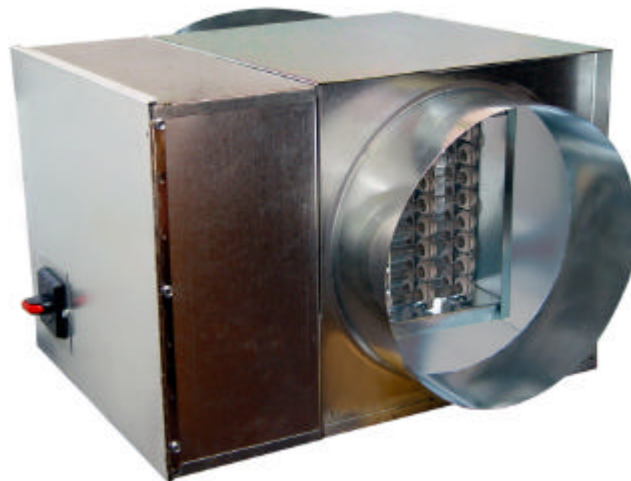

NEMA WEATHER PROTECTED CONSTRUCTION



N4 Accessory Code

NEMA enclosures for duct heaters and remote panels are available in a corrosion-resistant stainless steel or powder coated construction. They are designed for indoor and outdoor use, providing protection against windblown dust and rain. These enclosures are hinged with fully insulated covers that include pressure latches on all sides.

* The rear of the enclosure includes dense foam insulation but it is the responsibility of the installing contractor to completely seal the duct penetration and the back of the enclosure where it meets the duct work.

PRIMARY INTEGRAL COMPONENTS - ACCESSORY OPTIONS

UL LISTED ELECTRIC DUCT HEATERS

Pictures shown are representative only and may vary with requirements and availability.

MAGNETIC CONTACTOR

Disconnecting magnetic contactors (Option B6) are so arranged as to break all ungrounded lines. Disconnecting contactors, both magnetic or mercury type, that break all ungrounded lines are required on all UL listed duct heaters.

The number and amperage of the contactors will vary depending upon the KW and voltage.



MERCURY CONTACTOR

Disconnecting Mercury contactors (Option B3/B6) are usually used where silent operation and/or frequent cycling is desired. The design of the contactor virtually eliminates contact noise and provides for long expectant life under heavy use. Mercury contactors can only be installed in the vertical position.

AIRFLOW SWITCH

The airflow (pressure) switch (Option C1) is a diaphragm type device that senses the air pressure across the heater surface closing the electrical switch and allowing the heater to be activated. This device assures airflow is present before allowing the heater to energize. The airflow switch is available for either positive or negative air pressure. The pressure differential is $.05" \pm .02"$. This device is position-sensitive and cannot be mounted in a flat horizontal position.

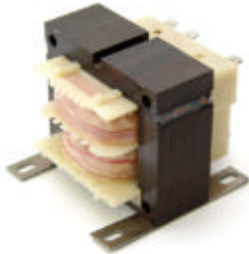

TRANSFORMER

Control transformers are available mounted in the control panel for primary voltages of 120, 208, 240, 277 and 480 with secondary voltages of 24, 208, 240. A Class II transformer (Option D1) may be used only for 24-volt secondary voltage and only up to 3 steps. All transformers are priced based on a maximum of 30 AMPS per step. This transformer includes internal primary over-current protection. All other transformer requirements (Option D2) include external primary over-current protection. Secondary fusing for use in conjunction with D1 or D2 transformers is available (Option D3).

POWER FUSING

UL and NEC require that heaters in excess of 48 AMPS be subdivided into branch circuits of 48 AMPS or less and be protected by fuses (Option F1). These are supplied by Warren Manufacturing. If circuit fusing on heaters of 48 AMPS or less is desired, price Option F3. For fusing per step (less than 48 AMPS per step) price Option F2. The fewest number of fuse blocks required for the particular KW, AMPS, and Steps will be furnished. The over-current protection (fuses) must be sized for 125% of the circuit load.



BACK-UP (SAFETY) CONTACTOR

Back-Up contactor (Option B5) is supplied as an addition to the primary controlling contactor or other device and is controlled only by the manual reset cutout. On an over-temperature condition, the back up is to be de-energized.

ACCESSORY OPTIONS

FAN CONNECTION

A set of terminal connections (Option A1) is provided for external connection to the fan circuit. This option is available for line voltage control only. Internal connection can vary and must be specified as to desired method.



THERMAL SAFETY DEVICES

A disc type automatic reset thermal safety cutout that de-energizes the heater element on overheating, and re-energizes the heater element after the temperature has lowered, is provided as standard equipment. The standard cutout temperature is 145°F.

A disc type manual reset thermal safety cutout (Option E1, 175° F.) can be provided as a secondary limit control in addition to the standard automatic reset. This device requires a reset button to be engaged to restore power to the heater element. The reset button may be located in the control panel door. A hinged control panel lid is supplied with this option. Also available is a remote manual reset (Option E5) which allows the device to be reset by use of a lock-out circuit utilizing a thermostat or remote switch to reset the limit.

A one-time manually replaceable secondary fuse link heat limit is provided as standard equipment. This device is installed in the line side of the heater element and has a standard cutout temperature of 300° F. This is replaceable without removal of the heater.



DISCONNECT SWITCH

A door interlocking disconnect switch can be provided to prevent the control panel door from being opened until the power to the heater is disconnected. This switch can be either non-fused (Option J2) or fused (Option J1). A hinged control panel door is standard with this option.

A non-door-interlocking panel mount disconnect switch (Option J6) can be provided within the amperage limits. Consult factory for details. This allows the power to be disconnected independent of the control panel door. A non-hinged control panel door is standard with this option. This disconnect switch can be used in connection with circuit fusing (Option F3) to provide a fused disconnect.



PILOT LIGHTS

Indicator lights may be installed on the side of the control panel to virtually show the heater operation mode. Pilot lights available are:

1. Control Circuit On (Option G1)
2. Each Step is On (Option G2)
3. Thermal Cutout is Open (Option G3)
4. Air Switch is Open (Option G4)
5. Pilot Light Power On (Option G5)
6. Pilot Light Fan On (Option G6)



SCR (Silicone Controlled Rectifier) CONTROL

The SCR control (Option L1) is used to provide continuous modulation from 0 to 100% of the heater capacity. It is available with a wall mounted controller (Option LA) or duct mounted controller (Option LB). The SCR Control can also be configured to accept a field supplied control signal: 0-10VDC interface (Option LC), 4-20ma interface (Option LD), 0-135 ohm interface (Option LE). If the SCR is to be controlled by a pneumatic or pulsed width modulated signal then a transducer (Option L3) must be selected.



TIME DELAY BETWEEN STEPS

To prevent all stages of an electric heater from being energized simultaneously, a time relay (Option C2-non-adjustable or Option CA – adjustable) may be employed. This relay will cause a predetermined delay between energizing of each additional stage after the previous stage has been energized.



PILOT RELAY

A pilot relay (Option B2) can be provided where the VA load of the contactor coils exceeds the load capacity of the thermostat or the low voltage transformer. When provided, the pilot relay is controlled by a 24-volt control circuit which in turn activates the coils of the heater contactors.



ACCESSORY OPTIONS

PROTECTIVE SCREEN

A protective screen (Option V6), that is installed on either the air inlet side or the air outlet side of the heater element, can be provided where it is possible for debris to be in the air stream of the duct and come in contact with the heater elements or for personal protection. The protective screen is standard on all heaters that are over 48" in either width or height.



P.E. (PNEUMATIC-ELECTRIC) SWITCH

P.E. Switch (Option C5, C6, C7) is used to change a pneumatic air pressure signal to an electric signal for the control circuit. The thermostat regulates the air pressure signal to the P.E. Switch which in turn opens and closes regulating the electric signal to the coil of the contactor. A load-carrying P.E. (Option C7) can be provided on most heaters less than 15 AMPS per step, thus eliminating the need for a contactor.

INSULATED CONTROL PANEL

To prevent possible condensation from forming in the heater control panel when the heater is installed in an air conditioning duct, an insulated control panel (Option Q1) is often specified.

This consists of insulating the outside of the control box closest to the duct to prevent metal contact between the control box and the duct, reducing or eliminating the condensation possibility.

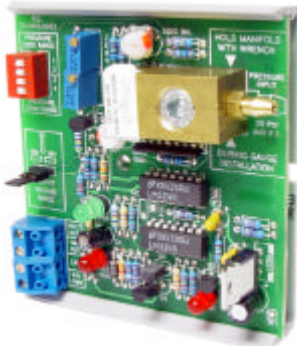
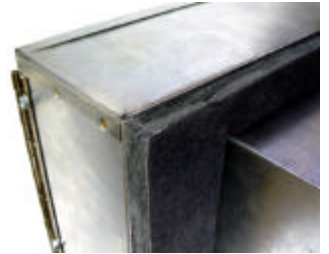

TRANSDUCER

A transducer (Option L3) is used when an SCR control system (Option L1) or step controller (Option K1) is required to be controlled with a pneumatic or pulsed width modulated signal. The transducer converts the pneumatic or pulsed width modulated input signal into a 0-10VDC analog signal that will directly control the SCR or step controller.

RECESSED TERMINAL BOX

A recessed terminal box (Option V4) is used when a restriction or obstruction may cause a lack of airflow across the electric heater surface. With this option, the distance between the control box and the heater element is increased as necessary to avoid the restriction. It is designed to allow the entire element to be exposed to the airflow.

The recessed depth can vary as required (1" Standard).



ACCESSORY OPTIONS

STEP CONTROLLER

A step controller (Option K1) is available for multiple heating stages in a pre-determined sequence. The number of steps being energized will be controlled by a proportional thermostat available in either a wall mount or duct mount style. The first stage of the element on is the last stage off. A power failure causes the step controller to recycle from start.

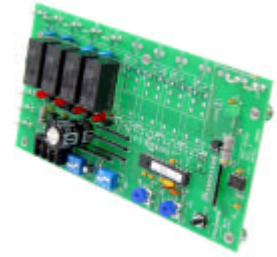

ROUND DUCT CONNECTION

The round duct connection (Option V7) accessory allows an easy method of installing an electric duct heater in a round sheet metal duct. The electric heater section comes factory installed in an adapter section with appropriately sized round pipe connections provided at the inlet and outlet for field connection.

FAN INTERLOCK RELAY

A fan interlock relay (Option B7) is supplied that utilizes external voltage either from the load side of the fan starter or from the fan control voltage circuit to prevent the heater from operating unless the fan is energized. The interlock voltage must be specified when this option is ordered. This option is often used with continuous fan operation systems.

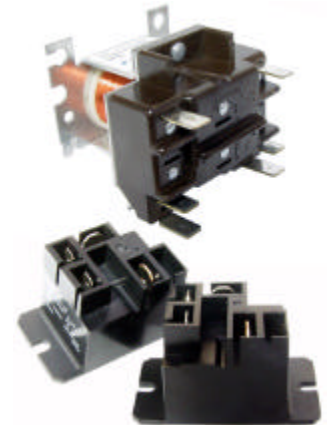

FAN CONTROL RELAY

A fan control relay (Option B1) energizes the fan simultaneously with the first stage of the heater. It utilizes the heater control circuit to energize the relay, which closes the relay contacts to energize the fan. This option is used where intermittent fan operation is desired. Not available on units with SCR controls.



CIRCUIT BREAKER

Circuit breakers (Option J3) may be supplied in place of power fusing for over-current protection. This device automatically trips to the disconnect (off) position in an over-current situation. After correcting the over-current situation it can be reset without requiring replacement.

PILOT SWITCH

A pilot switch (Option C3, C4) consists of a toggle switch installed on the control panel, that is wired in the control circuit to prevent the energizing of a heater stage (C4), or the entire heater (C3), by de-energizing the control voltage to the contactors. The pilot switch cannot be used as the disconnect switch as required by NEC.



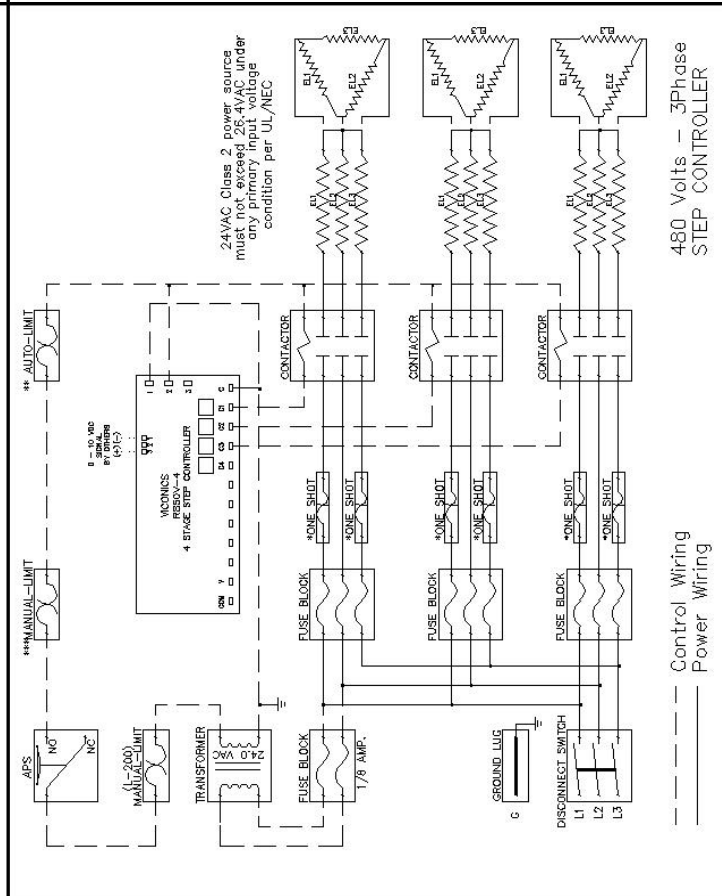
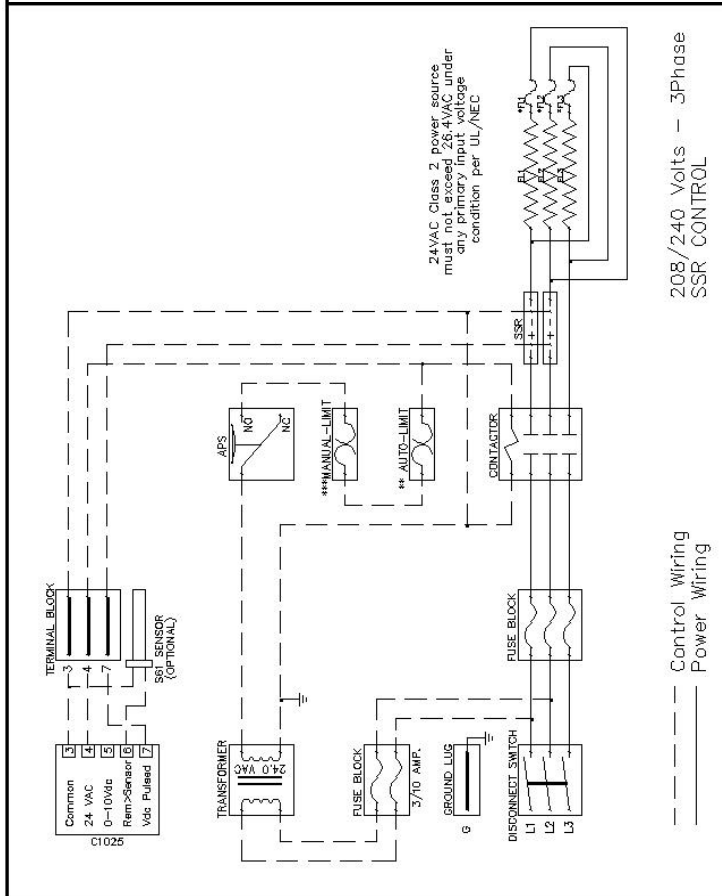
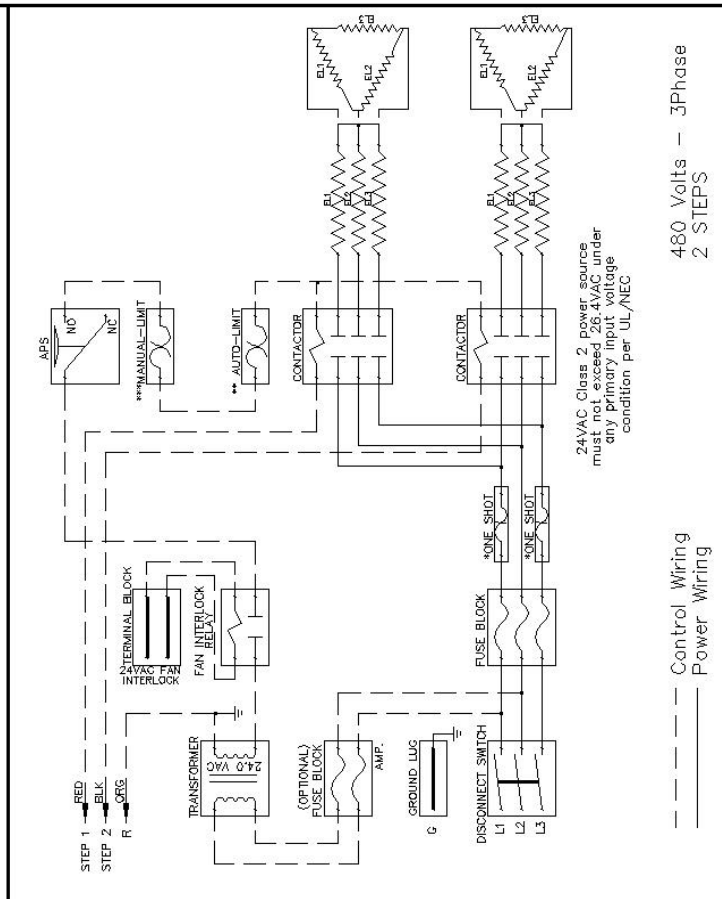
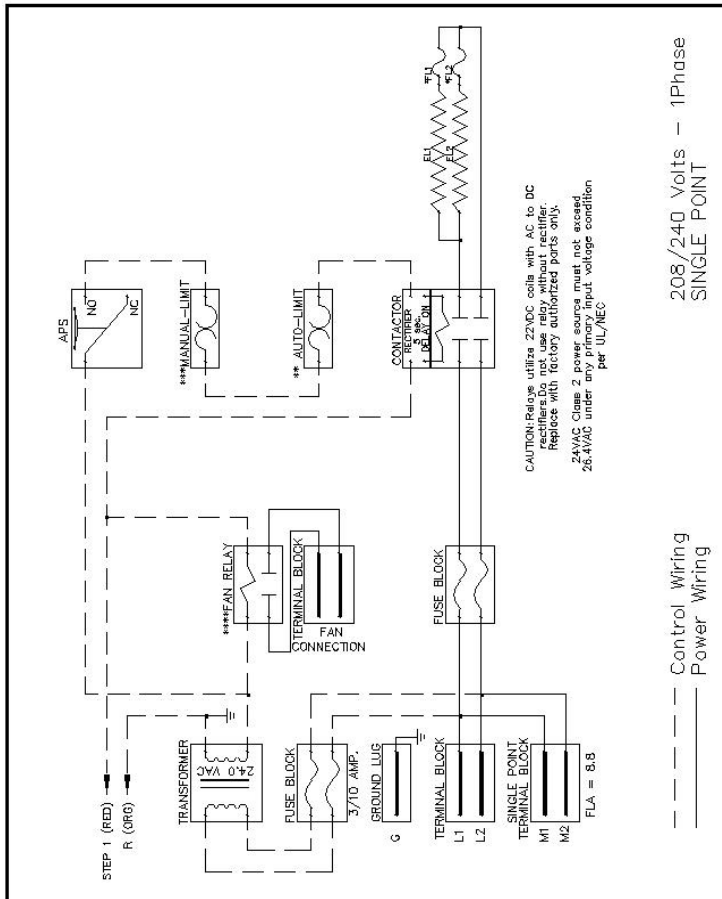

TYPICAL WIRING DIAGRAMS

HEATER DESIGN FEATURES

UNIQUE ELEMENT DESIGN

Warren Technology's design criterion for heating element selection is based on actual element operating temperature.

Warren selects all elements by its exclusive "Calculated Wire Temperature Method" a method which insures that elements in heaters operate within the designed electrical and temperature requirements, and do not exceed the melting point of the alloy **even in still free air**.

The system allows Warren to determine the exact operating temperature of the heater elements in specific condition.

The elements are designed to operate below the maximum allowable temperature recommended by the element alloys manufacturer under the worst possible condition. This process eliminates most problems associated with hot spots in heaters caused by poor air distribution.

This method of design allows Warren's Technology to predict operating temperatures and life spans of any given element in our duct heater product line and has resulted in a zero failure rate on units installed in the field over the past 10 years.

COMPUTERIZED SELECTION

A Computer Selection Program developed after years of research insures that Warren Technology's heater can meet an infinite number of size and voltage requirements. Utilizing a computer insures that every heater is going to perform consistently. Warren can tell exactly how the element is going to operate and how long it can be expected to last under specific requirements. Computer selection of component parts permits complete compatibility utilizing a manufacturing process where all duct heaters are produced from standard components incorporated in an exclusive modular design. This computer selection method is applied on all three basic product line categories, including Custom Built (CBK), Stock-Line (SL), and Quick Silver (QS) electric duct heaters.

CERAMIC SUPPORT SYSTEM

Warren Technology utilizes an element support system, which permits the ceramic element supports to expand and contract freely without cracking or breaking. The heavy support frame completely surrounds the individual ceramic insulators while allowing the insulators to "float" freely, eliminating any binding. The modular concept lends itself to selection of pre-determined distances between the exclusive support frames thus assuring optimum element support.

HEATER FRAME

Warren Technology employs the most modern technology available in the industry to construct the heater frames and boxes. Predetermined optimum element support spacing allows the modular concept to offer the choice of virtually any element rack size combination, and yet utilize the cost savings of volume production. All frames and boxes are constructed of 20 gauges, or heavier, hot dipped galvanized steel. The frame is integrally tied to the control box providing solid one-piece construction for ease of installation. Additionally, this construction allows almost any location relationship between the element rack and control box giving unlimited sizing flexibility.

PERMANENT ELECTRONIC FILE

A permanent electronic file is made for each control panel. The electronic file is retained as a future reference. Having this record on file allows Warren Technology to produce identical heaters at a later date, offer precise engineering assistance to the installing contractor or service personnel should it be required, or supply replacement parts identical to those originally furnished if necessary. This is a feature offered exclusively by Warren.

ENGINEERING INFORMATION

UL AND NEC REQUIREMENTS

The information listed is offered as a guide for electric duct heater requirements. It is based on the National Electric Code (NEC) and Underwriters Laboratory (UL) Space Heating Standard No. 1096. Although this is intended to assure that these heaters are manufactured to meet NEC and UL requirements, local electrical codes should be considered for compliance.

Over-temperature Protection - UL and NEC requires the manufacturer to provide two types of over-temperature protection. Warren supplies as standard a disc type automatic reset limit, which de-energizes the heater in the event of overheating. A secondary limit, consisting of a replaceable fuse link is provided, which operates at a higher temperature and de-energizes the heater in case of failure of the primary limit.

Over-current Protection - UL and NEC require that a heater in excess of 48 AMPS be subdivided into circuit of less than 48 AMPS each and built-in fusing be provided by the heater manufacturer. The over-current device (fuse or circuit breaker) must be rated for 125% of the circuit load and limited to 60 AMPS maximum. UL requires the over-current protective devices be supplied by the heater manufacturer.

Loss of Airflow Protection - UL and NEC require that a method be provided to prevent the duct heater element from being energized unless the fan circuit is energized and airflow is present. Warren provides a choice of 4 integral methods to meet this requirement: Fan Connection, Fan Control Relay, Fan Interlock Relay and Air Pressure Switch.

Transformer Protection - Transformers are required for heater operation unless an external control voltage source is available and where the heater power voltage is different from the control voltage. UL requires transformers to have primary over-current protection. The Class II transformer meets this requirement with built-in protection while all other non-Class II transformers supplied are primary fused externally. Secondary transformer fusing is available as an option to protect the control circuit but is not required by UL

Equipment Grounding - UL requires a grounding lug be installed by the manufacturer for field wiring connection. All Warren heater control panels contain a UL approved grounding lug.

Disconnect Location - NEC requires an equipment disconnect switch be installed at or within sight of the heater. Warren offers factory-installed disconnect switches (or they may be field supplied to comply with this requirement).

Contactors - UL requires that the heater manufacturer supply the contactors as a built-in integral component of the heater.

INSTALLATION INFORMATION

Good installation practice dictates certain guidelines be followed. Although the guidelines listed are general recommendations, Warren has the unique ability to custom design heaters to specifications involving unusual applications. Consult the factory for deviations to usual installation practices.

- Always consult local codes for compliance.
- Follow SMACNA guides and recommendations.
- Install heaters with the airflow in the proper direction as indicated by the arrow.
- Make electrical connections per UL and NEC.
- The heater should be installed 4ft. from air handler unless designed for internal mount or close coupling.
- Provide minimum 4ft. clearance from elbows, transitions, extractors, or similar turbulence producing devices.
- Reinforce duct where necessary to support the weight of the heater and prevent sagging.
- Allow sufficient clearance for servicing and removal if necessary.
- Units greater than 50KW should be controlled by a system with a recycling feature that will not allow all steps to be energized simultaneously. The absence of such a device causes severe damage to the equipment.
- The use of discharge air sensing devices to control this heating unit is **not** factory recommended and may void the warranty.