

Low Intensity Parts Instruction Sheet

MARK 17U-24 (P/N: TP-211A) Replacement

NOTE: Replaced/converted parts are NOT returnable for credit.

Contents

- MARK 17U-24 (P/N: TP-211A) Circuit Board.

NOTE: To ensure safe operation, circuit boards must be replaced with factory supplied parts.

Related Parts List

- Glo-Bar (P/N: TP-50)
- Glo-Bar Wire Harness (P/N: TP-214)
- Flame Rod (P/N: TP-222)
- Flame Rod Wire Harness (P/N: TP-222A)

Installation Instructions

- 1 Disconnect electrical supply voltage to the heater.
- 2 Remove the burner box cover on heater.
- 3 Disconnect wiring from the old circuit board and remove.
- 4 Install new MARK 17U-24 (P/N: TP-211A) circuit board and reconnect wiring.
- 5 Reconnect electrical power supply voltage. Cycle heater to verify proper operation. Check wiring if heater malfunctions.

IMPORTANT: Proper grounding and polarity are essential for the proof of flame safety device. If the systems is not grounded to a positive earth ground, it is unable to determine the presence of flame and will lock out.

Figure 1 • Internal Wiring Diagram

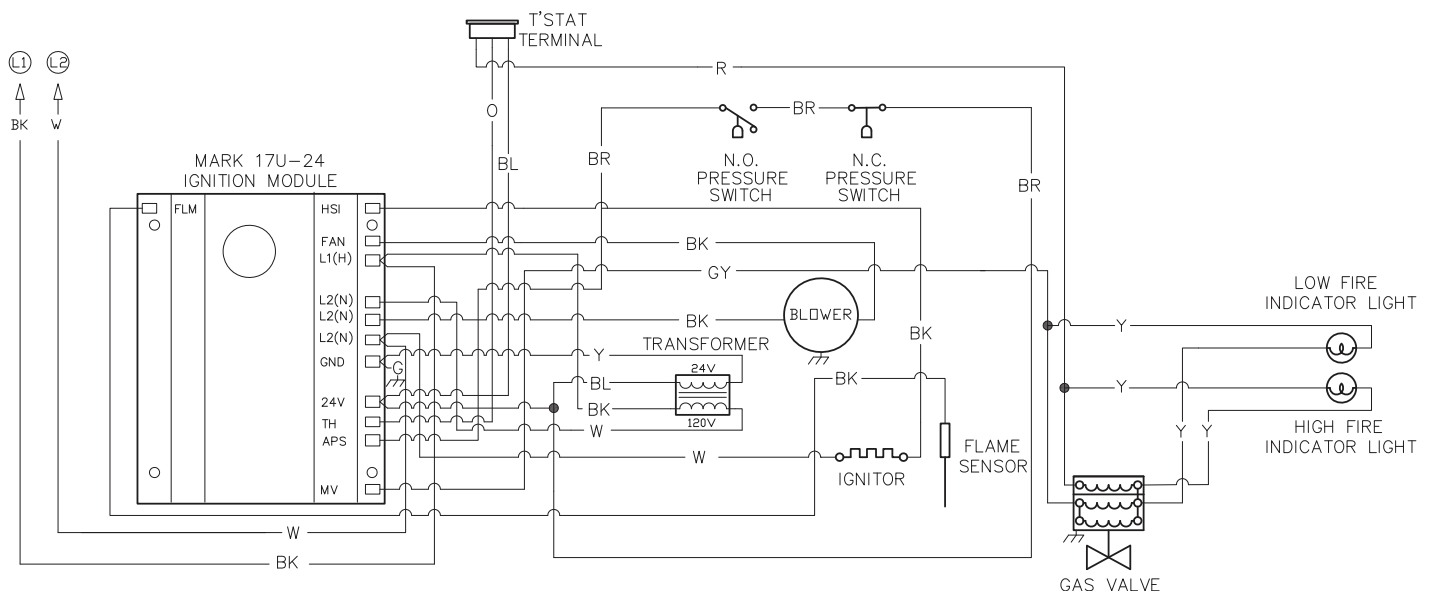

NOTE: If replacing any of the original wire supplied with the appliance, it must be with wiring material having a temperature rating of at least 105°C.

WARNING



Only trained, qualified gas installation and service personnel may install or service this equipment.

Improper installation, adjustment, alteration, service or maintenance can cause property damage, serious injury or death.

Contact the factory with any questions.