

DX3L Series Insert Manual



For complete installation instructions, see the Tube Heater General Manual that accompanies this insert manual.

RE-VERBER-RAY[®]
by Detroit Radiant Products Company

The DX3L Series Infrared Tube Heater is a positive pressure, single-stage radiant heater system. This insert manual is a supplement to the Tube Heater General Manual and provides specific information related to the DX3L series model. All persons involved with the installation, operation, and maintenance of the heater system must read and understand the information in this insert manual and the accompanying Tube Heater General Manual.

⚠ WARNING



Improper installation, adjustment, alteration, service, or maintenance can cause property damage, injury, or death. Read the installation, operation, and maintenance instructions thoroughly before installing or servicing this equipment.

This heater must be installed and serviced by trained gas installation and service personnel only. Failure to comply could result in personal injury, asphyxiation, death, fire, or property damage.



In locations used for the storage of combustible materials, signs must be posted to specify the maximum permissible stacking height to maintain the required clearances from the heater to the combustibles. Signs must either be posted adjacent to the heater thermostats or, in the absence of such thermostats, in a conspicuous location.



Not for residential use! Do not use this heater in the home, sleeping quarters, attached garages, etc. **Installation of a commercial tube heater system in residential indoor spaces may result in property damage, serious injury, asphyxiation, or death.**

For Your Safety

If you smell gas:

- Do not try to light any appliance.
- Do not touch any electrical switch.
- Do not use any phone in your building.
- Immediately call your gas supplier from a neighbor's phone.
- Follow the gas supplier's instructions.
- If you cannot reach your gas supplier, call the fire department.

INSTALLER: Present this manual to the end user.

Keep these instructions in a clean and dry place for future reference.

Model#: _____ Serial #: _____
(located on rating label)

LIODX3L-Rev.16215
Print: 2M-03/18 (CDS)
Replaces: LIODX3L-2M-02/17 (CDS)

Contents

1.0 Safety	3
Safety Labels and Their Locations	3
Clearances to Combustibles	4
2.0 Installation	6
Gas Requirements	6
Electrical Requirements	6
Internal Wiring Diagrams	7
Thermostat Connection	8
Controlling Multiple Heaters with a Single Control Device	9
Thermostat Location	9
Specifications	10
Tube Installation Sequence	11
3.0 Operation	12
Sequence of Operation	12
Diagnostics	12
Operational Indicator Lights	13
LED Diagnostic Codes	13
4.0 Troubleshooting Guide	14
5.0 Parts	18
Burner Assembly Components	18
Tube and Reflector Components	19
Kit Contents Check List	20
Approvals	20
Limited Warranty	20

NOTE: See **page 10** for a list of available models and specifications.

1.0 Safety

⚠ WARNING



Improper installation, adjustment, alteration, service, or maintenance can cause property damage, serious injury, or death. Read and understand the installation, operating, and maintenance instruction thoroughly before installing or servicing this equipment. Only trained, qualified gas installation and service personnel may install or service this equipment.

Safety Labels and Their Locations

Product safety signs or labels should be replaced by the product user when they no longer are legible. Contact either your local distributor or the product manufacturer for obtaining replacement signs or labels.

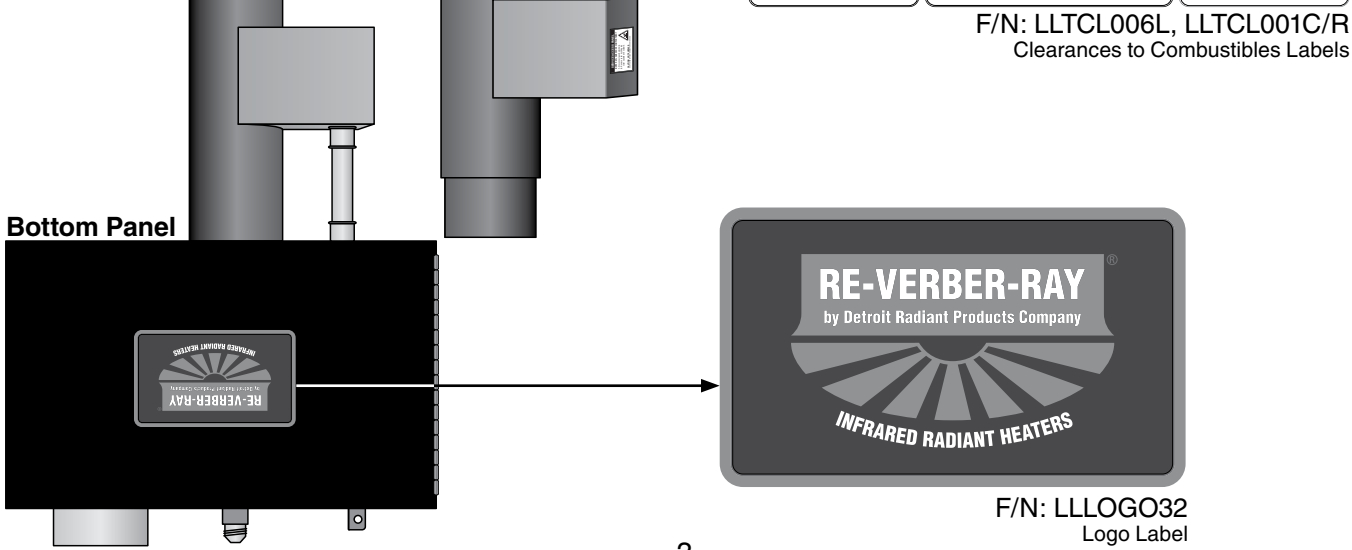
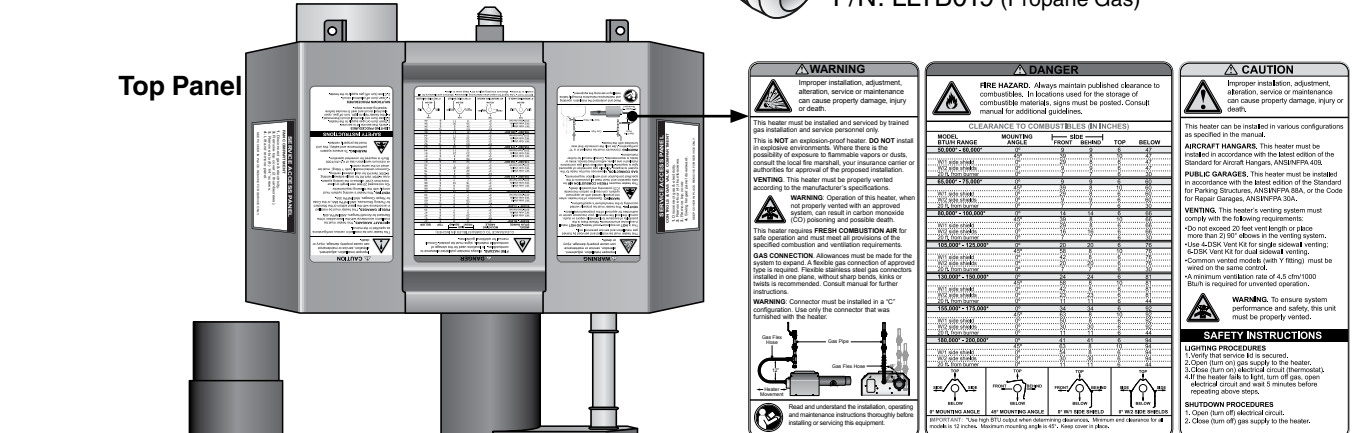
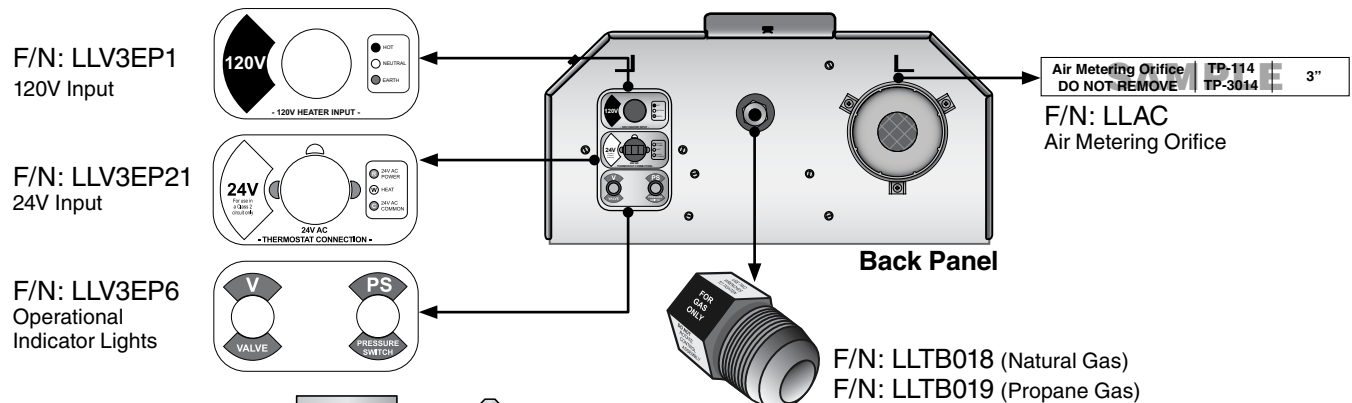

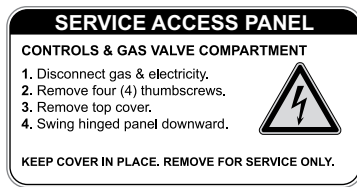
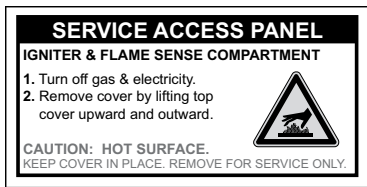

DX3L-40-125N VERSION: 06/15
 SERIAL NUMBER: 0010000000000001 OPTIONS: None
 PRODUCTION CODE: DX3L-C1

BILL OF MATERIALS				
COMPONENT	PART NO.	DESCRIPTION	COMPONENT PART NO. DESCRIPTION	
CIRCUIT BOARD	TP-8018	Fanless	INDUCER FAN	1/2" for Inducer Assy
GAS VALVE	TP-1040	24VAC Single Stage	POWER CORD	8X Conduit Connector
GAS INLET	TP-304	1/2" NPT for Flow	WIRE	3/16"
IGNITER	TP-30A	Slider	TP-3080	400 Ohm Resistor
IND. LIGHT #1	TP-853A	Amber LED Ind	TP-309	Terminal Block
IND. LIGHT #2	TP-1435A	Green LED Ind	TP-605	100% 24VAC
IND. LIGHT #3	None		TP-353	Wire Harness

MODEL SPECIFICATIONS DATA

MODEL SPECIFICATIONS DATA	TUBE & REFLECTOR PARTS
AIR ORIFICE SIZE: TP-304 1/4"	BURNER: TP-302
BURNER: TP-302	COMB. TUBE: TP-30A
GAS ORIFICE SIZE: 2# DMS	HANGERS: TP-108
1ST PILES SWITCH: TP-246	REFLECTORS: TP-200
2ND PILES SWITCH: NA	RODUANT TUBE: TP-30A
WIRING DIAGRAM: LLRT10	TUBE CLAMP: TP-218

Please contact the factory for assistance, parts information and/or list prices at 586-756-0900 or visit www.revbernsy.com

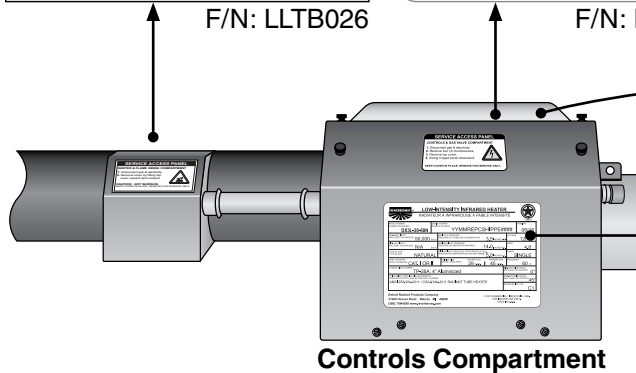

Burner Control Box Component Label (located inside the center compartment lid)

LOW-INTENSITY INFRARED HEATER
 RADIATEUR A INFRAROUGE A FAIBLE INTENSITE

MODEL NUMBER	SERIAL NUMBER	DESIGN
DX3L-20-50N	YYMMREPCSHIPPE####	06/15

MAX HEAT RENT	MAX. HEAT INPUT	MAXIMUM INLET PRESSURE	MAXIMUM INLET PRESSURE	VOLTAJE
50,000 BTU/H	50,000 BTU/H	0.5 INCHES W.C.	0.5 INCHES W.C.	120 VAC

MIN. HEAT RENT	MIN. HEAT INPUT	MINIMUM INLET PRESSURE	MINIMUM INLET PRESSURE	TEMP.
N/A	N/A	0.5 INCHES W.C.	0.5 INCHES W.C.	4.8

TYPE OF GAS	VENT CATEGORY	VENT TYPE	VENT SIZE	VENT FREQUENCY
NATURAL	CAT. I OR II	VENT	5.0 INCHES I.D.	SINGLE

VENT CATEGORY	VENT TYPE	VENT SIZE	VENT FREQUENCY
TP-26A	VENT	29 DMS	45 DMS

DETROIT RADIANT PRODUCTS COMPANY
 21400 Hoover Road Warren MI 48099
 (586) 756-0900 www.revbernsy.com

Rating Plate

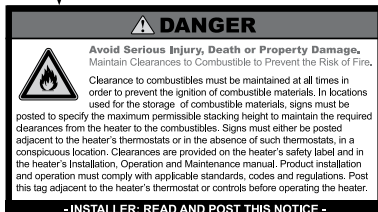
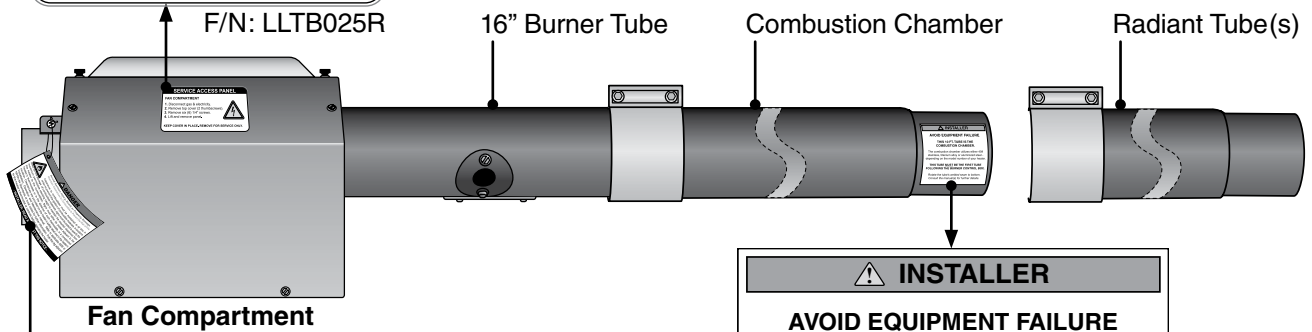
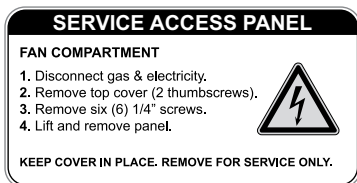

F/N: LL001 - Clearance Safety Tag (Affix adjacent to heater's thermostat)

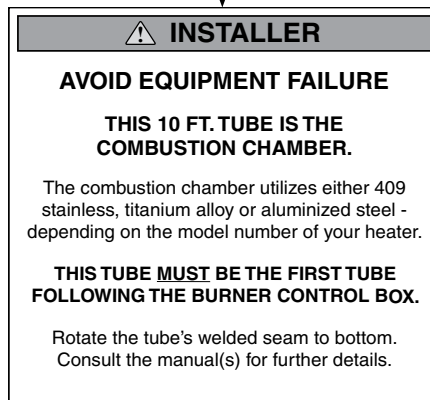

F/N: LLTB004 (orange)
 (150,000 - 200,000 BTU/h models and all heaters with 409 stainless steel tubes)

Clearances to Combustibles

WARNING

Placement of explosive objects, flammable objects, liquids, and vapors close to the heater may result in explosion, fire, property damage, serious injury, or death. Do not store or use explosive objects, liquids, or vapor in the vicinity of the heater.

Clearance to combustibles is defined as *the minimum distance that must exist between the tube surface, or reflector, and any combustible items* (see Figure 1.1). It also pertains to the distance that must be maintained from moving objects around the tube heater. When installing the tube heater system, clearances to combustibles for the model tube heater and configuration must be maintained. Refer to Chart 1.1 to determine the required distances for your model.

Chart 1.1 • Clearances to Combustibles in Inches (see Figure 1.1 for Mounting Angles)

Model Number	Mounting Angle*	Side		Top	Below	
		Front	Behind			
DX3L (20, 30, 40) - 50, 60 [N, P]	0°	9	9	6	47	
	45°	39	8	10	47	
	with 1 side shield	0°	29	8	6	47
	with 2 side shields	0°	9	9	6	47
	20 ft. from burner	0°	7	7	6	30
DX3L (20, 30, 40) - 75 [N, P]	0°	9	9	6	60	
	45°	39	8	10	60	
	with 1 side shield	0°	29	8	6	60
	with 2 side shields	0°	9	9	6	60
	20 ft. from burner	0°	7	7	6	30
DX3L (30, 40, 50) - 100 [N, P]	0°	14	14	6	66	
	45°	39	8	10	66	
	with 1 side shield	0°	29	8	6	66
	with 2 side shields	0°	16	16	6	66
	20 ft. from burner	0°	7	7	6	30
DX3L (30, 40, 50, 60) - 125 [N, P]	0°	20	20	6	76	
	45°	58	8	10	76	
	with 1 side shield	0°	42	8	6	76
	with 2 side shields	0°	20	20	6	76
	20 ft. from burner	0°	7	7	6	30
DX3L (40, 50, 60) - 150 [N, P]	0°	24	24	6	81	
	45°	58	8	10	81	
	with 1 side shield	0°	42	8	6	81
	with 2 side shields	0°	23	23	6	81
	20 ft. from burner	0°	11	11	6	44
DX3L (40, 50, 60, 70) - 175 [N, P]	0°	34	34	6	92	
	45°	63	8	10	92	
	with 1 side shield	0°	50	8	6	92
	with 2 side shields	0°	30	30	6	92
	20 ft. from burner	0°	11	11	6	44
DX3L (50, 60, 70, 80) - 200 [N, P]	0°	41	41	6	94	
	45°	63	8	10	94	
	with 1 side shield	0°	54	8	6	94
	with 2 side shields	0°	30	30	6	94
	20 ft. from burner	0°	11	11	6	44

*Heaters mounted on an angle between 0° and 45° must maintain clearances posted for 0° or 45°, whichever is greater. The stated clearances to combustibles represents a surface temperature of 90°F (50°C) above room temperature. Building materials with a low heat tolerance (such as plastics, vinyl siding, canvas, tri-ply, etc.) may be subject to degradation at lower temperatures. It is the installer’s responsibility to ensure that adjacent materials are protected from degradation.

Figure 1.1 • Mounting Angles

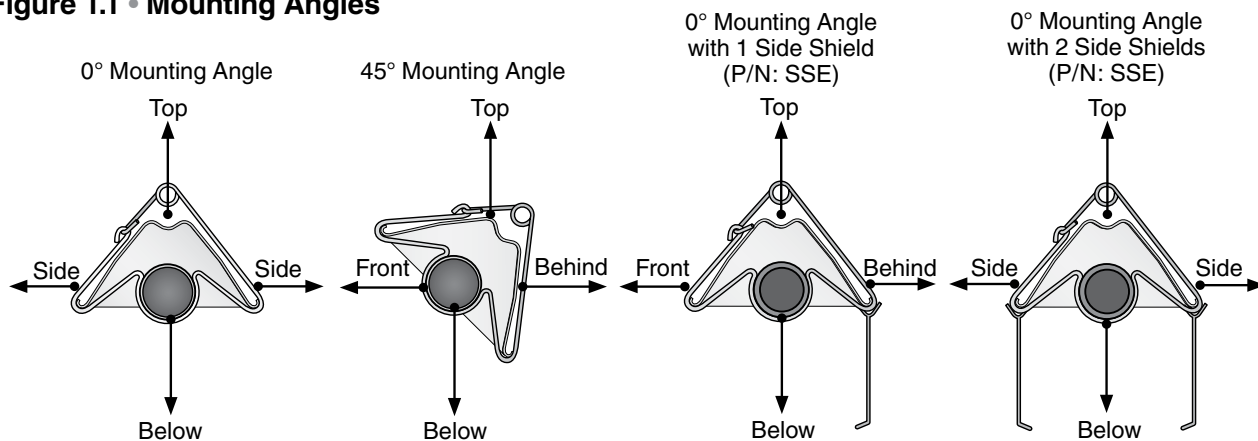

2.0 Installation

! WARNING



Improper installation, adjustment, alteration, service, or maintenance can cause property damage, serious injury, or death. Read and understand the installation, operating, and maintenance instructions thoroughly before installing or servicing this equipment. Only trained, qualified gas installation and service personnel may install or service this equipment.

Not for residential use! Do not use this heater in the home, sleeping quarters, attached garages, etc. **Installation of a commercial tube heater system in residential indoor spaces may result in property damage, serious injury, or death.**

Instructions for the following are detailed in the Tube Heater General Manual:

- Design considerations
- Hanger suspension and placement
- Tube layout and assembly
- Burner control box suspension
- Reflectors (and accessories)
- Venting and combustion air intake
- Gas requirements
- Baffle assembly

Note: Electronic versions of all manuals are available at www.detroitradiant.com.

Gas Requirements

Type of Gas	Required Manifold Pressure	Minimum Inlet Pressure	Maximum Inlet Pressure
Natural	3.5 Inches W.C.	5.0 Inches W.C.	14.0 Inches W.C.
Propane	10.0 Inches W.C.	11.0 Inches W.C.	14.0 Inches W.C.



IMPORTANT: Consult the Tube Heater General Manual for gas connection requirements.

Electrical Requirements

- 120 VAC - 60 Hz, GND, 3-wire
- 24 VAC thermostat connection
- Starting current 4.8 amps
- Running current 1.1 amps

! WARNING



Shock Hazard. Disconnect power supply before making wiring connections to prevent electrical shock and equipment damage.

Any original factory wiring that requires replacement must be replaced with wiring material having a rating of at least 600 V, 105°C.

All field installed wiring to the tube heater must be done in accordance with the national, state, provincial, and local codes, and to the guidelines in this manual. In the United States, refer to the most current revisions to the Electrical Code ANSI/NFPA 70 and in Canada, refer to the most current revisions to the Canadian Electrical Code CSA C22.1 Part 1. The unit must be electrically grounded according to these codes. Line polarity must be observed when making field connections.

Internal Wiring Diagrams

Before wiring this appliance, check the existing wiring; replace if necessary. If any of the original wire supplied with the appliance must be replaced, it must be replaced with copper wiring material having a rating of at least 600V, 105°C.

Figure 2.1 • Internal Wiring Diagrams

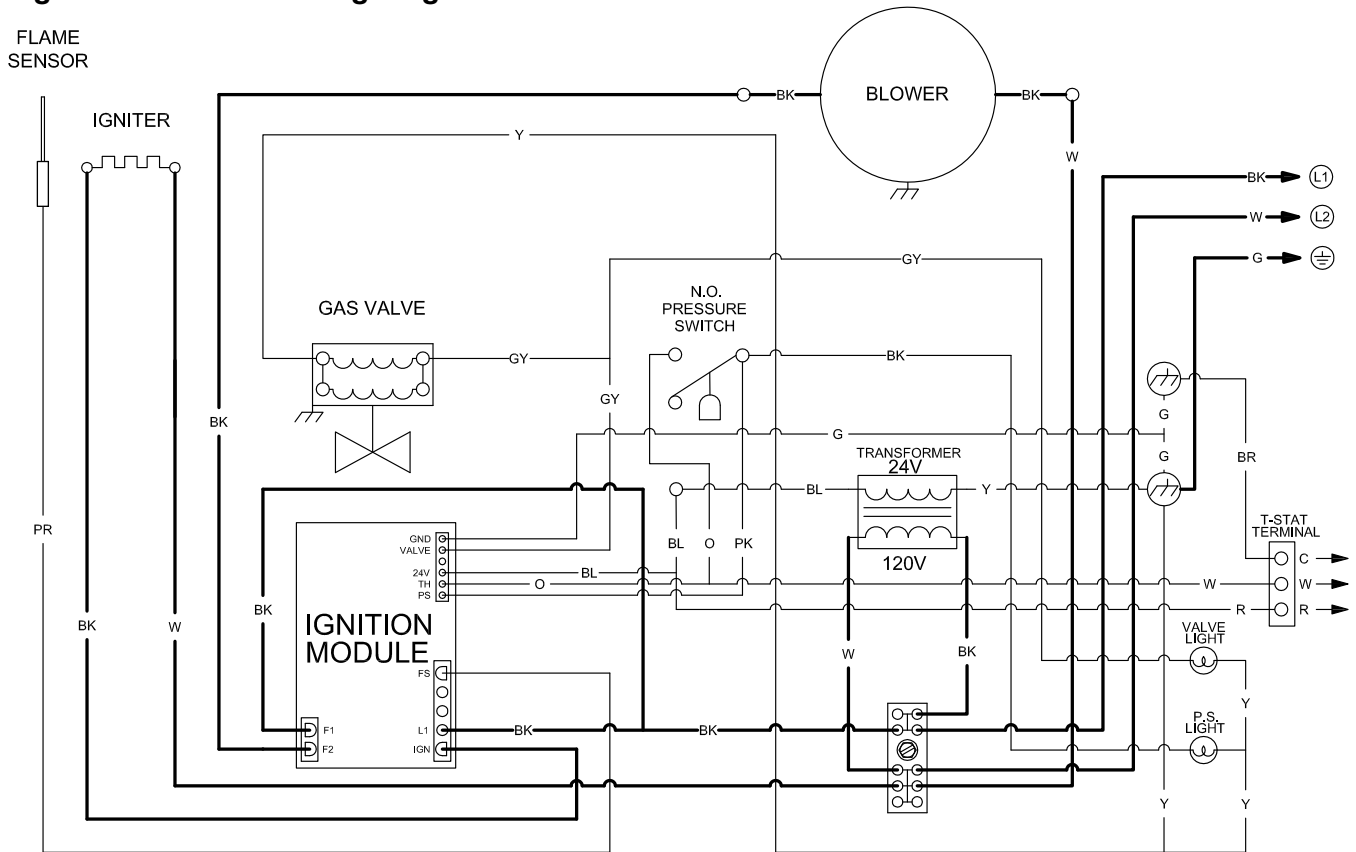

WIRING INFORMATION:

LINE VOLTAGE:

- FACTORY STANDARD —————
- FACTORY OPTION - - - - -
- FIELD INSTALLED - - - - -

LOW VOLTAGE:

- FACTORY STANDARD —————
- FACTORY OPTION - - - - -
- FIELD INSTALLED - - - - -

Field Wiring Supply Voltage

Before proceeding with electrical connections, ensure that the supply voltage, frequency, phase, and current capacity meet the requirements specified on the rating plate. A dedicated line voltage supply with properly sized wire should run directly from the main electrical panel to the heater. The power to the unit must be protected with a circuit breaker appropriate for the load. The unit must be electrically grounded in accordance with local codes, or in their absence, with the latest edition of the National Electrical Code, ANSI / NFPA 70 and/or the Canadian Electrical code CSA C22.1, latest edition.

⚠ CAUTION

The power supply to the heater must be within +/- 5% of the voltage rating as indicated on the rating plate of the appliance. If input power does not meet these specifications, contact your utility company.

A means shall be provided to disconnect the heater from all ungrounded conductors, and is recommended to be located within 5 feet of the service access panel. If conditions do not allow for this, then the branch-circuit switch or circuit breaker shall be permitted to serve as the disconnecting means where the switch or circuit breaker is within sight from the appliance or is lockable in accordance with the National Electrical Code.

The main electrical supply enters at the rear of the heater utilizing 1/2" electrical knock-out. When routing the electrical supply conduit to the unit, ensure that it does not interfere or obstruct the heater's service access panel.

Thermostat Connection

NOTE: Different thermostats operate according to their particular features. Refer to the thermostat's specifications for details.

Prior to connecting the thermostat wire to the heater, check to make sure the wires will be long enough to allow for the heater to freely expand and contract without causing undue strain on the wires or terminal. Use 18 gauge wire (or larger) that is suitable for a NEC Class 2 rating for thermostat connections.

Each DX3L series heater requires a thermostat rated for 24 VAC to operate. The heater comes standard with a terminal strip for making the thermostatic connection, located on the back panel.

⚠ WARNING



Edges of sheet metal holes may be sharp. Use gloves as a precaution when routing wires.

The thermostat terminal designations are as follows:

R: 24 VAC Power

W: Call for Heat

C: Common for 24 VAC Power (if required for thermostat power)

24 VAC is supplied from an internal 40 VA transformer. **DO NOT** supply 24 V to the terminal strip.

Figure 2.2 • Single Heater, Single Thermostat Connection

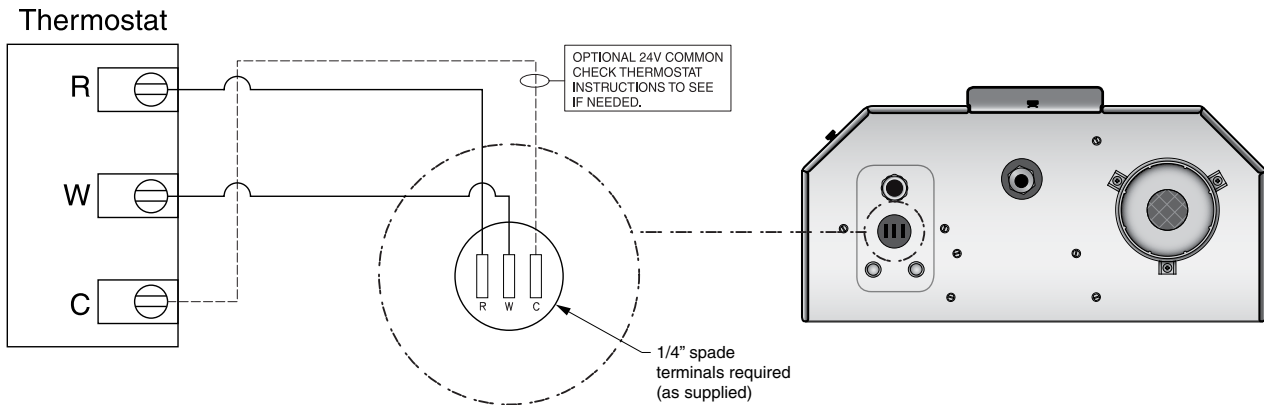

Controlling Multiple Heaters with a Single Control Device

When multiple heaters are operated by the same control device (for example, common vented heaters), an external relay kit (Part #ERK) must be utilized per heater. This allows the heater's 24 V supply voltage to be isolated from the external control voltage of the thermostats. The ERK is to be installed on or near the heater. Follow the instructions that accompany the accessory for more information and wiring diagrams.

Figure 2.3 • Multiple Heaters, Single Thermostat Connection with External Relay Kit

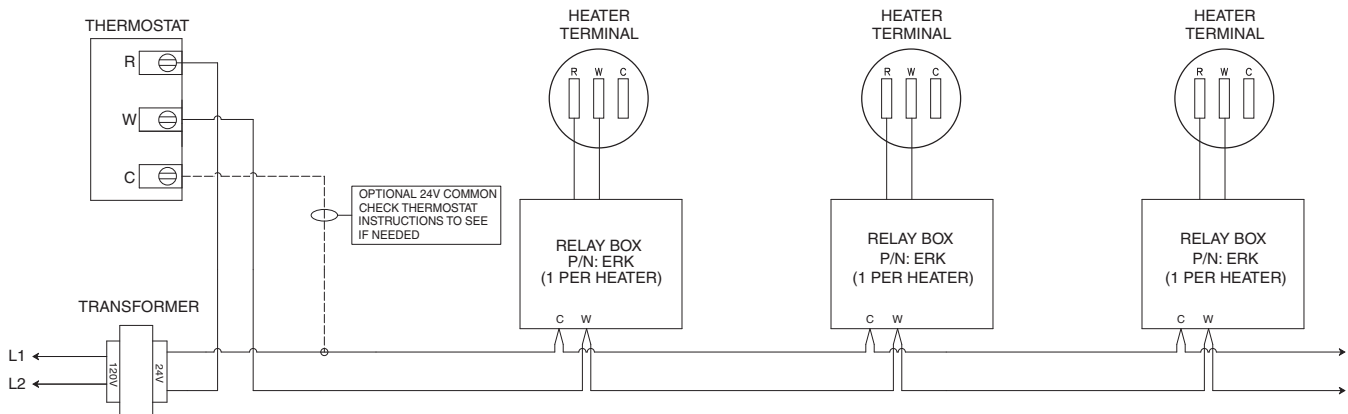

Thermostat Location

The location of the thermostat should be determined by the desired heating requirements and be mounted on an inside wall five (5) feet above the finished floor. Locate the thermostat in a conspicuous location, away from where it could be influenced by heat from the unit or other sources, as this may cause the unit to short cycle. Care should be given to locate the thermostat away from drafts or frequently opened doors. To prevent drafts inside the wall from affecting the thermostat's performance, plug hole for the wire with insulation or suitable caulk. For further information, see the accompanying instructions with the thermostat.

Specifications

Chart 2.1 • Specifications

Model Number	Gas Type (Select One)	BTU/h	Straight Length	U-Tube Length	Standard Weight (lbs.)	Stainless Steel Weight (lbs.)	Recommend Mounting Height [^]	Combustion Chamber (Black Coated)	Radiant Emitter Tube(s) (Black Coated)	36" Baffle Quantity
DX3L-20-50	Nat. or Prop.	50,000	21'-9"	13'-1"	120	N/A	9' to 15'	Alum	Alum	5
DX3L-20-60	Nat. or Prop.	60,000	21'-9"	13'-1"	120	N/A	10' to 15'	Alum	Alum	5
DX3L-20-75	Nat. or Prop.	75,000	21'-9"	13'-1"	120	145	11' to 18'	Alum	Alum	5
DX3L-30-50	Nat. or Prop.	50,000	31'-5"	**17'-9"	160	N/A	10' to 15'	Alum	Alum	5
DX3L-30-60	Nat. or Prop.	60,000	31'-5"	**17'-9"	160	N/A	11' to 18'	Alum	Alum	5
DX3L-30-75	Nat. or Prop.	75,000	31'-5"	**17'-9"	160	195	12' to 20'	Alum	Alum	5
DX3L-30-100	Nat. or Prop.	100,000	31'-5"	**17'-9"	160	195	13' to 23'	Alum	Alum	5
DX3L-30-125	Nat. or Prop.	125,000	31'-5"	**17'-9"	160	195	14' to 25'	Alum	Alum	6
DX3L-40-50	Nat. or Prop.	50,000	41'-1"	22'-9"	190	N/A	11' to 18'	Alum	Alum	5
DX3L-40-60	Nat. or Prop.	60,000	41'-1"	22'-9"	190	N/A	11' to 18'	Alum	Alum	5
DX3L-40-75	Nat. or Prop.	75,000	41'-1"	22'-9"	190	235	12' to 20'	Alum	Alum	4
DX3L-40-100	Nat. or Prop.	100,000	41'-1"	22'-9"	190	235	13' to 23'	Alum	Alum	4
DX3L-40-125	Nat. or Prop.	125,000	41'-1"	22'-9"	190	235	14' to 25'	Alum	Alum	5
DX3L-40-150*	Nat. or Prop.	150,000	41'-1"	22'-9"	190	235	15' to 27'	Titan	Alum	5
DX3L-40-175*	Nat. or Prop.	175,000	41'-1"	22'-9"	190	235	16' to 30'	Titan	Alum	5
DX3L-50-100	Nat. or Prop.	100,000	50'-9"	**27'-5"	235	290	15' to 27'	Alum	Alum	2
DX3L-50-125	Nat. or Prop.	125,000	50'-9"	**27'-5"	235	290	15' to 27'	Alum	Alum	3
DX3L-50-150*	Nat. or Prop.	150,000	50'-9"	**27'-5"	235	290	16' to 30'	Titan	Alum	3
DX3L-50-175*	Nat. or Prop.	175,000	50'-9"	**27'-5"	235	N/A	17' to 35'	Titan	Alum	3
DX3L-50-200*	Nat. or Prop.	200,000	50'-9"	**27'-5"	235	N/A	18' to 40'	Titan	Alum	2
DX3L-60-125	Nat. or Prop.	125,000	60'-5"	32'-5"	265	330	16' to 30'	Alum	Alum	2
DX3L-60-150*	Nat. or Prop.	150,000	60'-5"	32'-5"	265	330	17' to 35'	Titan	Alum	2
DX3L-60-175*	Nat. or Prop.	175,000	60'-5"	32'-5"	265	N/A	17' to 35'	Titan	Alum	2
DX3L-60-200*	Nat. or Prop.	200,000	60'-5"	32'-5"	265	N/A	18' to 40'	Titan	Alum	2
DX3L-70-175*	Nat. or Prop.	175,000	70'-1"	**37'-3"	300	N/A	19' to 42'	Titan	Alum	2
DX3L-70-200*	Nat. or Prop.	200,000	70'-1"	**37'-3"	300	N/A	19' to 42'	Titan	Alum	2
DX3L-80-200*	Nat. or Prop.	200,000	79'-9"	42'-1"	330	N/A	20' to 45'	Titan	Alum	2

* Model requires stainless steel tube clamp (P/N: TP-220) to be located at the seam between the primary combustion chamber and the secondary combustion tube downstream of the burner control box.

** Model requires 5EA-SUB accessory package when installing in a 'U' configuration (P/N: TF1B).

[^] Factory recommended mounting heights are listed as a guideline.

IMPORTANT: Reference box label to determine the number of required baffles sections for each model heater.

Alum = Black coated aluminized treated steel.

Titan = Black coated titanium stabilized aluminized steel.

Tube Installation Sequence

Figure 2.4 • Tube Installation Sequence

Important! The combustion chamber and radiant tube sections must be installed in the following order.

20 Foot

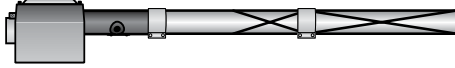

30 Foot

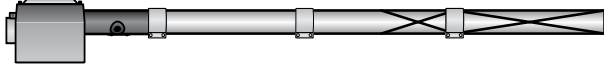

40 Foot



Stainless Steel Clamp on 150-175 MBH models (P/N: TP-220).

50 Foot

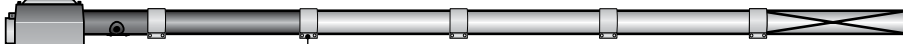

Stainless Steel Clamp on 150 - 200 MBH models (P/N: TP-220).

60 Foot



Stainless Steel Clamp on 150 - 200 MBH models (P/N: TP-220).

70 Foot

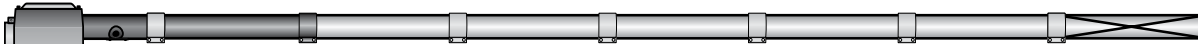

Stainless Steel Clamp Location (P/N: TP-220).

80 Foot



Stainless Steel Clamp Location (P/N: TP-220).

Key

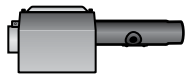

Burner Control Box with 16-inch Burner Tube



Standard Tube Clamp



Black Coated Combustion Chamber Tube*



Stainless Steel Tube Clamp (P/N: TP-220)
150-200 MBH models only - Located between 1st and 2nd 10 ft. tube sections.



Black Coated Aluminized Combustion Chamber/Radiant Emitter Tube



Baffle Location

*Aluminized tubes (50,000 to 125,000 BTU/h models), titanium tubes (150,000 to 200,000 BTU/h models) .

NOTE: Refer to the Tube Heater General Manual, Chart 3.6 (page 23) for secured reflector joints.

3.0 Operation

⚠ WARNING



This heater must be installed and serviced by trained gas installation and service personnel only.

Do not bypass any safety features or the heater's built in safety mechanisms will be compromised.

Note: Reference the Tube Heater General Manual for installation requirements.

Sequence of Operation

Standby: The ignition module (circuit board) continually checks for internal faults, circuit integrity, and relay contact positioning.

Starting Circuit: Upon a call for heat, the control verifies that the pressure switch(es) are in their proper positions. The control energizes the fan. Once operational static pressure is achieved, the pressure switch will close initiating the ignition sequence. The hot surface igniter is powered and the gas valve opens after 45 seconds. If the flame is not sensed, the heater will attempt to re-ignite for a total of 3 trials for ignition before proceeding to soft lockout.

Running Circuit: After ignition, the flame rod monitors burner flame. If sense of flame is lost, the control closes the gas valve within one second and a new trial sequence (identical to the starting sequence) is initiated. If flame sense is not established within 8.5 seconds, the heater will attempt two additional ignition sequences before proceeding to soft lockout. The control can be reset by briefly interrupting the power source.

Shut Down: When the thermostat is satisfied, the fan will enter a two (2) minute post-purge cycle.

Diagnostics

Lockout:

The controls will automatically lockout the heater system when an external or system fault occurs. There are two types of lockout:

Soft Lockout: The heater will attempt to light three times. In the event of a failed attempt to light (gas pressure, valve, no flame sense etc.), the heater will enter a soft lockout period for 30 minutes and then attempt to light three more times before entering hard lockout mode.

Hard Lockout: If proof of flame is not established, a component failure occurs, or blockages are evident, the heater will enter a hard lockout. If lockout occurs, the control can be reset by briefly interrupting the power source. Refer to Charts 3.1 & 3.2 for a description of LED codes.

Externally located operational indicator lights are provided to assist in troubleshooting of the heater. Refer to pages 13-17 for additional troubleshooting.

Operational Indicator Lights

The externally located operational indicator lights are provided to assist in troubleshooting of the heater. Refer to the following pages for additional troubleshooting.

Figure 3.1 • Operational Indicator Lights

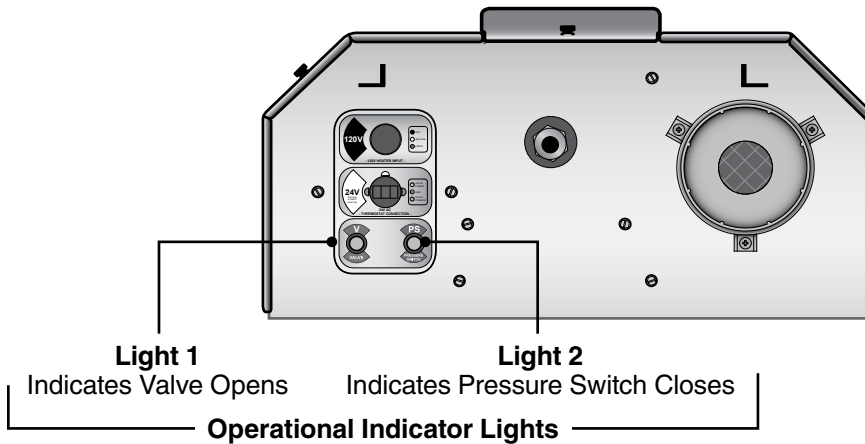

Chart 3.1 • LED Diagnostic Codes - Fenwal Circuit Board

LED CODE	FAULT STATUS	FAULT CODE DELAY*
Initial flash on power up, then steady off	No fault, normal operation	No delay
Steady on	Module failure/Internal fault	No delay
1 flash	Ignition failure	3 minutes
2 flashes	APS (Air Proving Switch) (Fan/Intake/Exhaust)	0-30 seconds
3 flashes	Lockout	17 minutes
4 flashes	Solenoid valve fault/Leaky valve/ Flame amplifier fault	No delay
No flash on 117 V start-up	Transformer fault	No delay

*Some LED codes have a time delay before the LED will flash.

Chart 3.2 • LED Diagnostic Codes - Capable Controls Board

LED CODE	FAULT STATUS	FAULT CODE DELAY*
Initial flash (Red) on power up; during ignition	Normal operation	Immediate
Steady flash (Green) during Ignition	Normal operation	Immediate
Steady on (Green) after flame sense.	Normal operation	1 minute
1 flash (Red)	Ignition failure	3 minutes
1 flash (Red)	Reverse Polarity	30 seconds
2 flashes (Red)	Ignitor error	12 seconds
3 flashes (Red)	Gas valve error	
4 flashes (Red)	Line voltage frq. error	
5 flashes (Red)	Internal control error	
6 flashes (Red)	Pressure switch error	

*Some LED codes have a time delay before the LED will flash.

4.0 Troubleshooting Guide

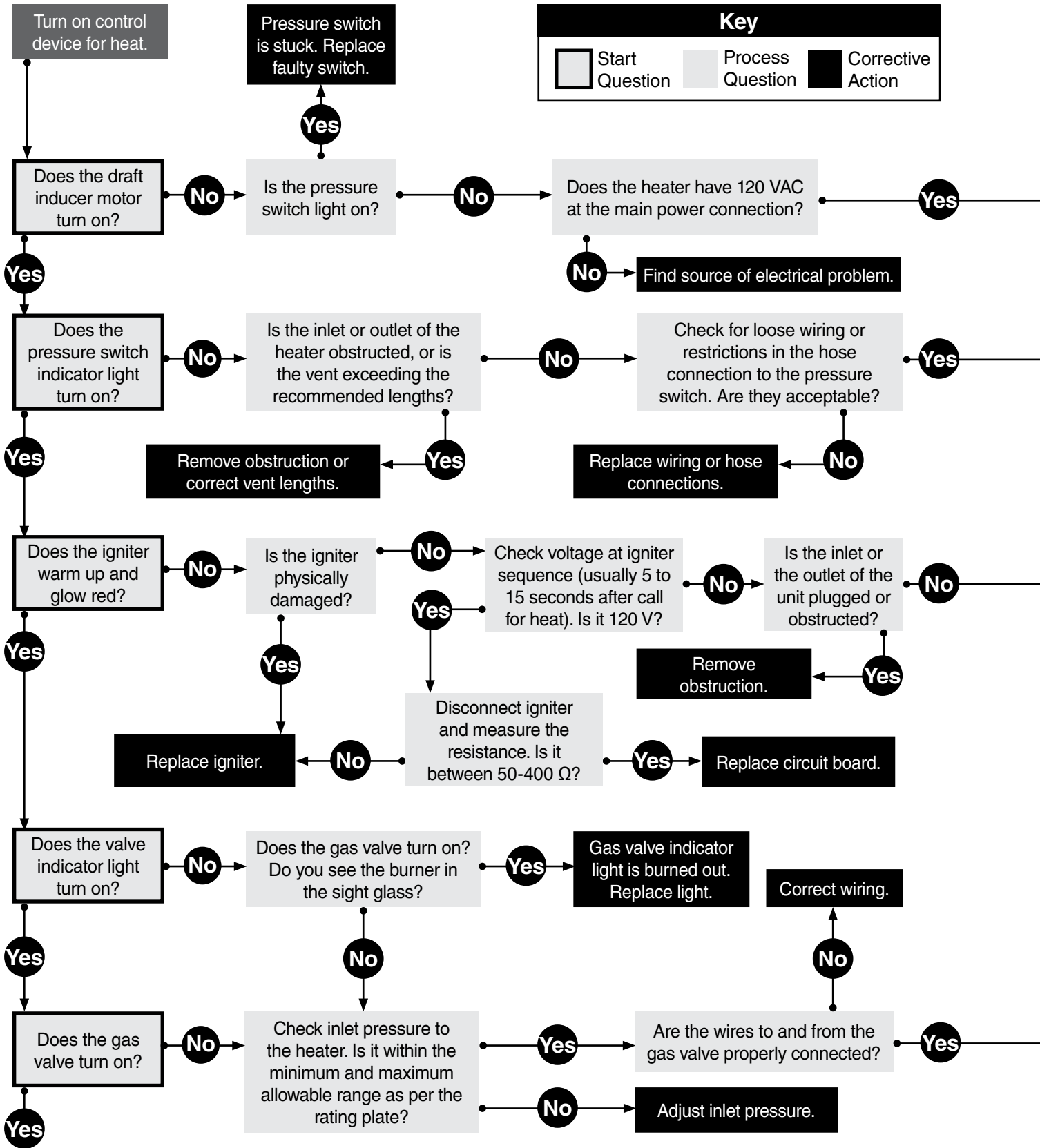

Continued on page 16

NOTICE

Bypassing any switch is intended for testing purposes only. Do not leave switch bypassed during normal operation or the heater's built-in safety mechanisms will be compromised.

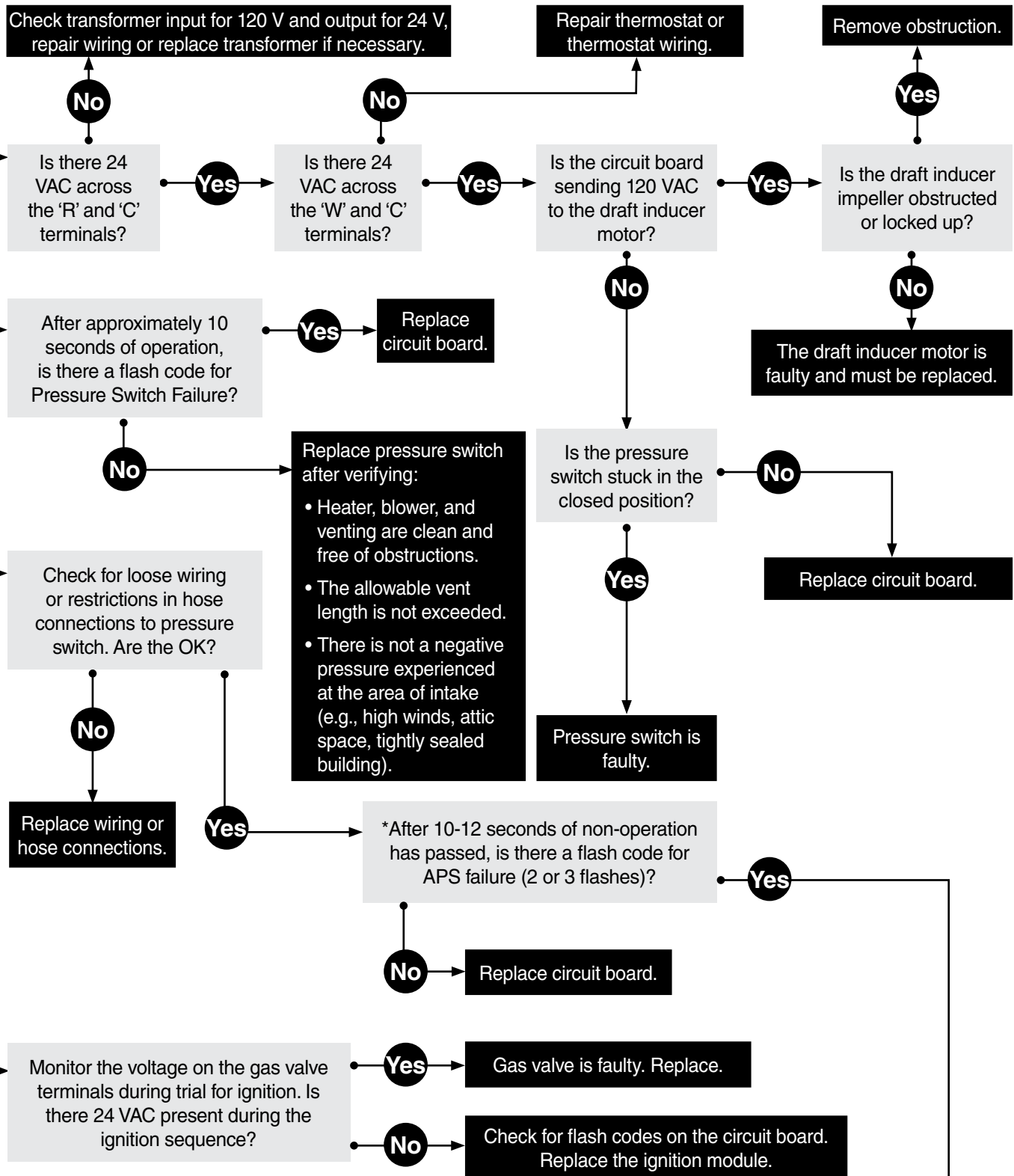

* Refer to LED diagnostic Fault Code Chart.

Continued on page 17

Continued from page 14

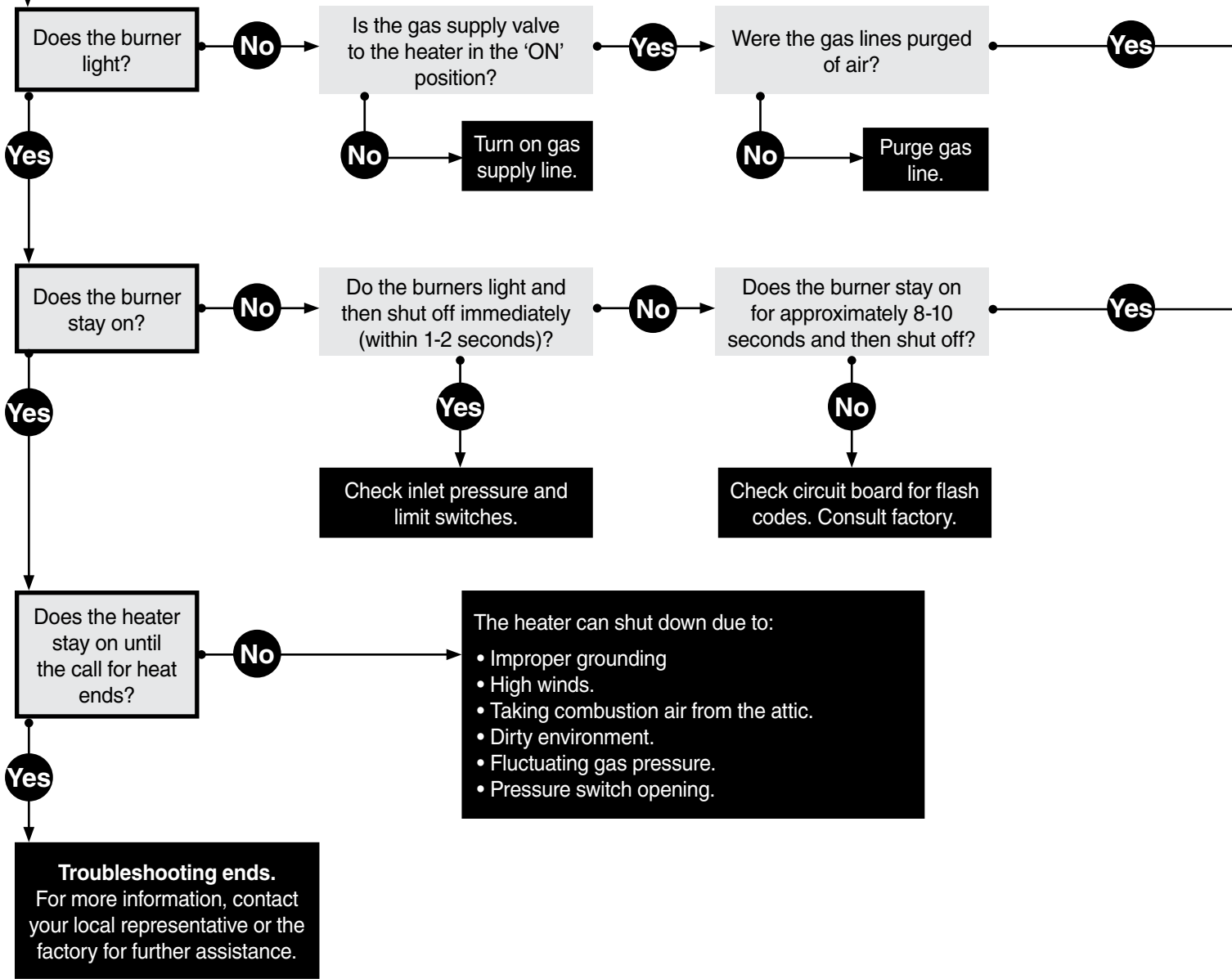

Continued from page 15

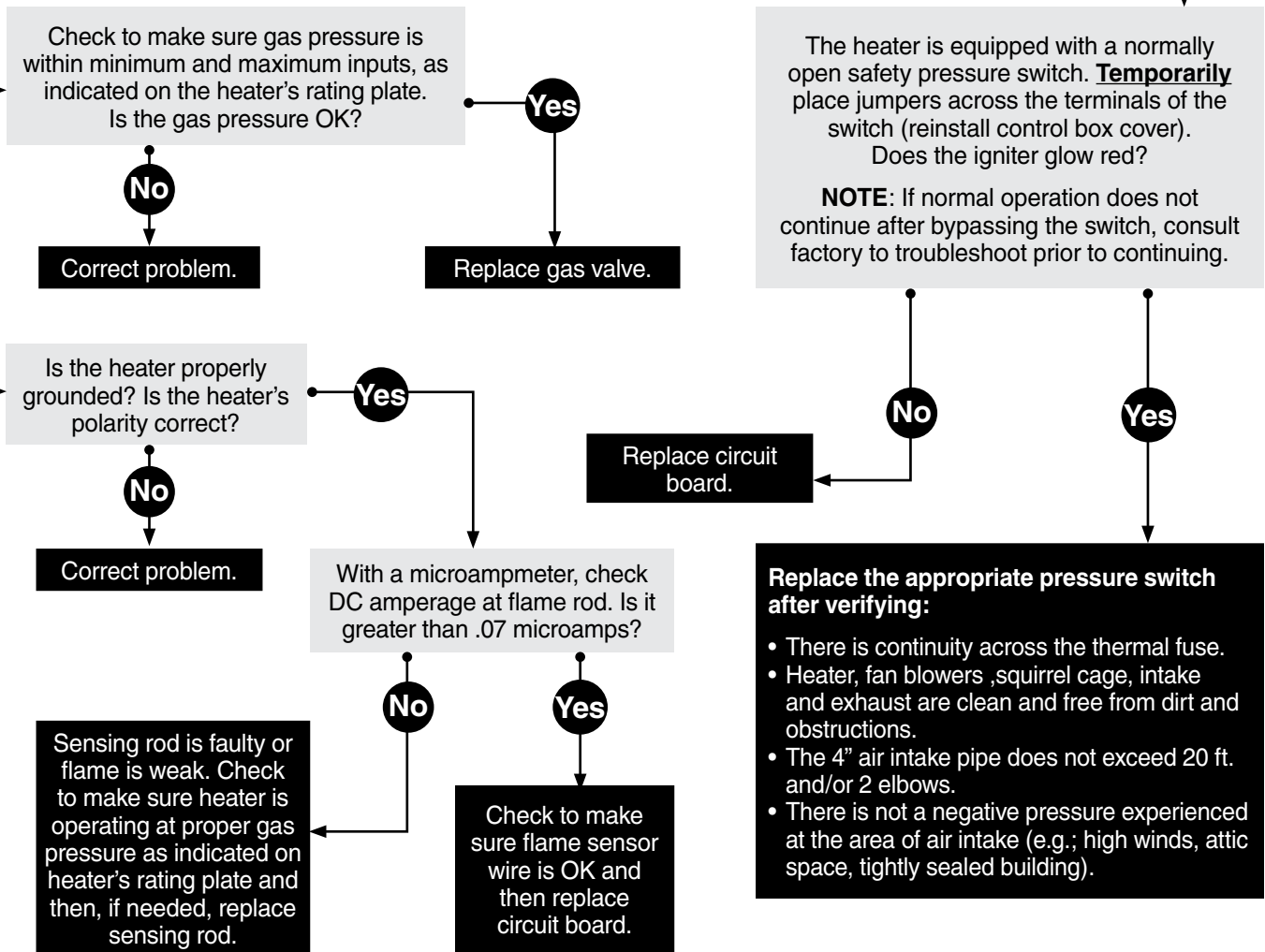

NOTICE

Bypassing any switch is intended for testing purposes only. Do not leave switch bypassed during normal operation or the heater's built-in safety mechanisms will be compromised.

5.0 Parts

Figure 5.1 • Burner Assembly Components

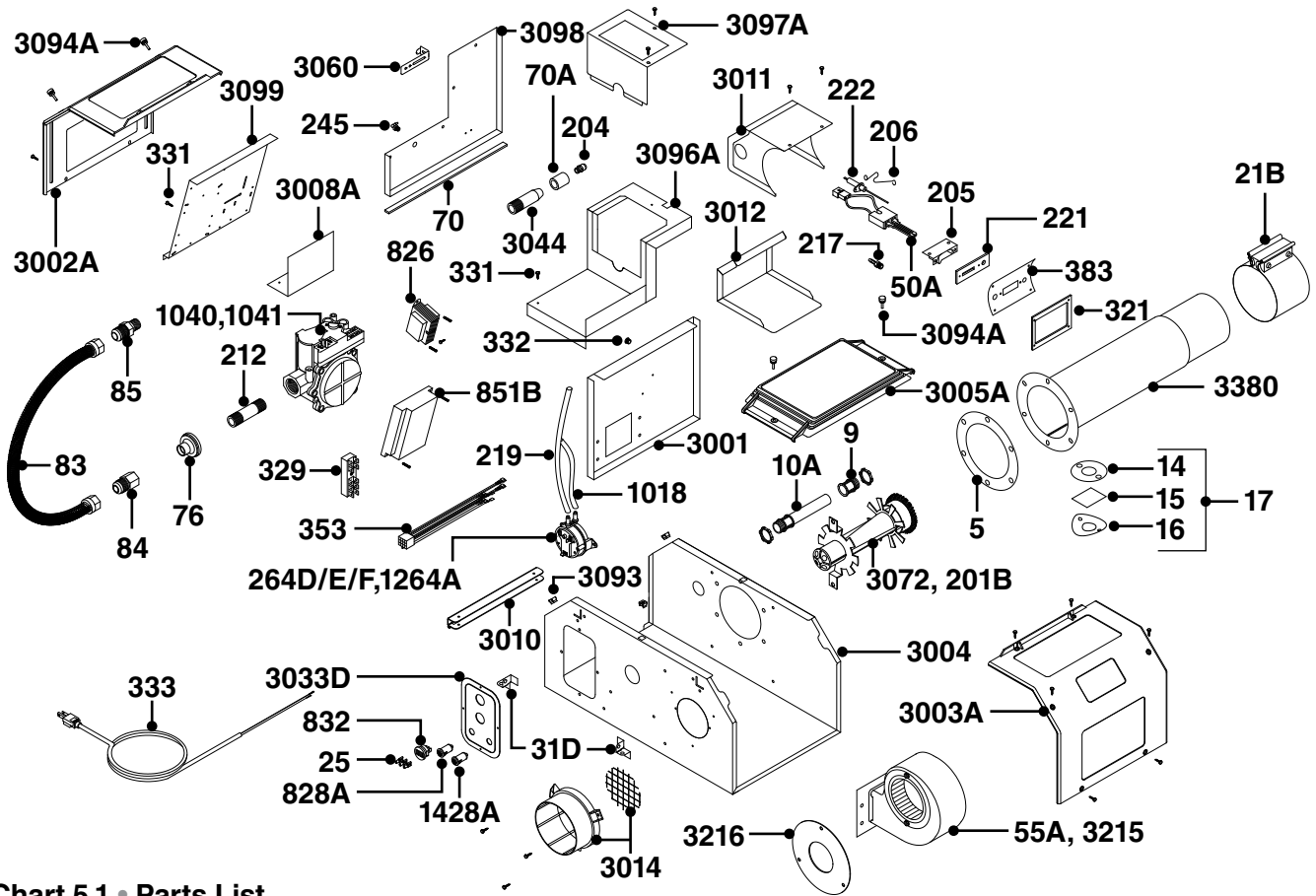

Chart 5.1 • Parts List

Part #	Description	Part #	Description
TP-5	Flange Gasket	TP-70	1/2" x 10" Control Box Gasket
TP-9	Conduit Coupling	TP-70A	1" x 6" Manifold Gasket
TP-10A	Conduit	TP-76	Rubber Grommet
TP-14	Sight Glass Gasket	TP-82	Reflector Center Support (RCS)
TP-15	Sight Glass	TP-83	1/2" x 24" C.S.S.T. Flexible Gas Connector
TP-16	Sight Glass Washer	TP-84	1/2" N.P.T (Female) to Male Flare Fitting
TP-17	Sight Glass Kit	TP-85	1/2" N.P.T. (Male) to Male Flare Fitting
TP-19B	4" Wire Hanger with Tension Spring	TP-105	Aluminum Reflector End Cap
TP-20C	10 ft. Polished Aluminum Reflector	TP-106	Reflector End Cap Clips (8 pcs.)
TP-20D*	10 ft. Stainless Steel Reflector	TP-113	Reflector Tension Spring
TP-21B	4" Standard Tube Clamp	TP-201B	Mid-High Burner (Color Code - TAN)
TP-25	1/4" Female Spade Terminal (Qty. 3)	TP-204	Gas Orifice (consult factory)
TP-26A	10 ft. Aluminized Radiant / Combustion Tube	TP-205	Glo-Bar™ Holder
TP-26B	10 ft. Titanium Stabilized Combustion Tube	TP-206	Glo-Bar™ Holder Spring Clip
TP-26D*	10 ft. 304 Stainless Steel Radiant Tube	TP-212	1/2" N.P.T. x 3" Pipe Nipple
TP-26E*	10 ft. 409 Stainless Steel Combustion Tube	TP-217	1/8" N.P.T. Brass Barb Fitting
TP-31D	Interlocking Mounting Bracket (Qty. 2)	TP-219	12"-3/16" ID Pneumatic Tube for Pressure Switch
TP-50A	Glo-Bar™ Igniter	TP-220	Stainless Steel Tube Clamp (150- 200 MBH)
TP-55A	1/20 hp Inducer Assembly (50-150 MBH)	TP-221	Glo-Bar™ Holder Gasket
TP-65I	3 ft. Interlocking Turbulator Baffle	TP-222	Flame Rod

* Optional upgrade or add-on item.

Figure 5.2 • Tube and Reflector Components

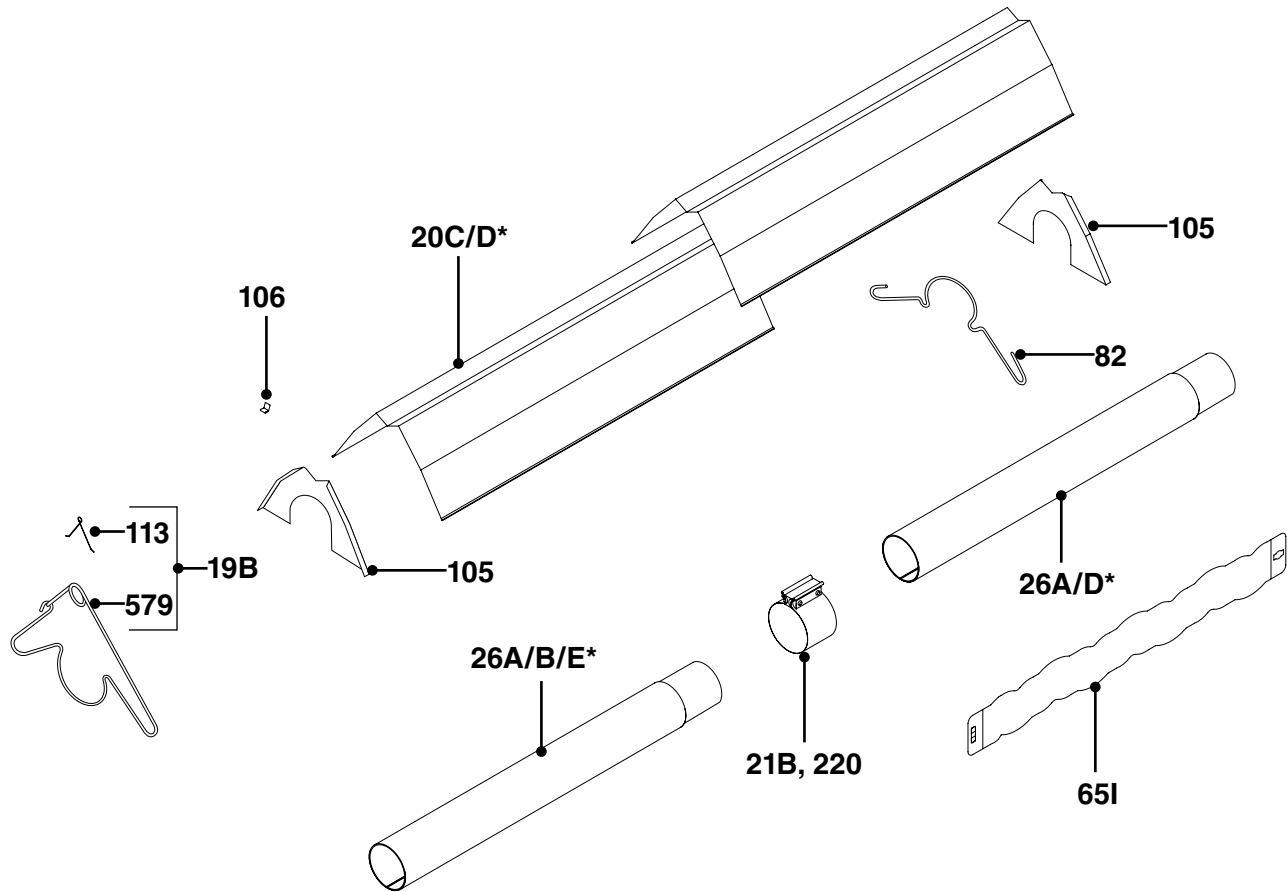
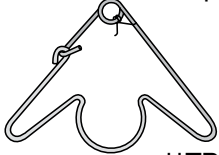

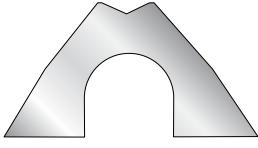

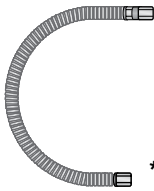
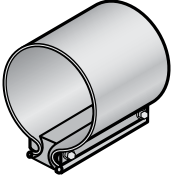
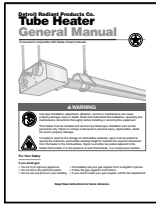



Chart 5.2 • Parts List

Part No.	Description	Part No.	Description
TP-245	1/8" Plastic N.P.T. 90° Barb Fitting	TP-3002A	Plastic End Panel, Control Compartment
TP-264D	Differential Pressure Switch, 60 to 75 MBH	TP-3003A	Plastic End Panel, Fan Compartment
TP-264E	Differential Pressure Switch, 50 MBH	TP-3004	Control Box
TP-264F	Differential Pressure Switch, 150 to 200 MBH	TP-3005A	Plastic Valve Chamber Lid
TP-321	Ignition Plate Gasket	TP-3008A	Gas Valve Mounting Bracket
TP-329	1/4" Male Spade Terminal Block	TP-3010	Service Panel Hinge
TP-331	Green Self-Tap Ground Screw (Qty. 2)	TP-3011	Igniter Box
TP-332	1/4" Divider Grommet	TP-3012	Igniter Box Cover
TP-333	60 in. Black 120 V Power Cord with Ground	TP-3014	Plastic Air Orifice with Screen
TP-353	Wire Harness for Ignition Controller	TP-3033D	Power Entry Plate
TP-383	Glo-Bar™ Igniter Plate	TP-3044	Gas Manifold
TP-579	4" Wire Hanger w/o Tension Spring	TP-3060	Pressure Switch Mounting Bracket
TP-826	40 VA Transformer	TP-3072	Low BTU Burner (Color Code - GREEN)
TP-828A	Yellow Indicator Light, 24 VAC	TP-3093	#8-32 Cage Nut (Qty. 4)
TP-832	Thermostat Terminal Strip	TP-3094A	#8-32 x 1/2" Metal Thumb Screw (Qty. 4)
TP-851B	Circuit Board	TP-3096A	Valve Compartment Bottom Panel
TP-1018	20"-3/16" ID Pneumatic Tube for Pressure Switch	TP-3097A	Valve Compartment Top Panel
TP-1040	Gas Valve - Natural Gas	TP-3098	Valve Compartment Side Panel
TP-1041	Gas Valve - Propane Gas	TP-3099	Controls Mounting Panel
TP-1264A	Differential Pressure Switch, 100 to 125 MBH	TP-3215	1/15 hp Inducer Assembly (175-200 MBH)
TP-1428A	Green Indicator Light, 24 VAC	TP-3216	Restrictor Plate (175-200 MBH)
TP-3001	Divider Panel	TP-3380	16" HSI Burner Tube w/Flange and Fittings

Kit Contents Check List

Chart 5.3 • Kit Contents for DX3L Series - Reference the length column for your model.

DX3L Series Kit Contents								
TP-19B 4" Hanger with Reflector Tension Spring  **TP-19C	TP-82 4" Reflector Center Support (RCS)  **TP-829	TP-105 Reflector End Cap  **TP-105A	TP-106 Reflector End Cap Clip 	TP-25 1/4" Female Spade Terminal 	TP-83 24" Stainless Steel Flexible Gas Connector  **TP-83A	TP-21B 4" Tube Clamp  **TP-220	LIOGT3 Tube Heater General Manual 	LIODX3L DX3L Series Insert Manual 
Part No.	Description	20 ft.	30 ft.	40 ft.	50 ft.	60 ft.	70 ft.	80 ft.
TP-19B	4" Hanger w/ Tension Spring	3	4	5	6	7	8	9
TP-21B	4" Tube Clamp	2	3	4*	5*	6*	7*	8*
TP-25	1/4" Female Spade Terminal	3	3	3	3	3	3	3
TP-82	4" Reflector Center Support	2	3	4	5	6	7	8
TP-83	24" S.S. Flexible Gas Connector	1	1	1	1	1	1	1
TP-105	Reflector End Cap	2	2	2	2	2	2	2
TP-106	Reflector End Cap Clip	8	8	8	8	8	8	8
LIOGT3	General Tube Heater Manual	1	1	1	1	1	1	1
LIODX3L	DX3L Series Insert Manual	1	1	1	1	1	1	1
Filled By:								

* **NOTE:** One 4" stainless steel tube clamp (P/N: TP-220) is provided for each 150,000 - 200,000 BTU/h model. Place as shown on page 11.

** Part number for models upgraded with stainless steel options.

Approvals

- CSA
- Indoor Approval
- Outdoor Approval with OD-Kit
- Commercial Approval

Limited Warranty

- 3 years - Burner box components
- 5 years - Combustion and radiant tubes
- 10 years - Stainless steel burner
- See page 36 of the General Tube Heater Manual for terms and conditions.



© 2018 Detroit Radiant Products Co.
 21400 Hoover Road • Warren, MI 48089
 Phone: (586) 756-0950 Fax: (586) 756-2626
 www.detroitradiant.com • sales@drp-co.com

