

High Intensity Parts Instruction Sheet

3-Prong Electrode (32-508) Replacement

NOTE: When replacing a 2-prong electrode (P/N: 22-508) with a 3-prong electrode (P/N: 32-508) a circuit board and wiring harness change is required. See Chart 1.

Parts List

- 3-Prong Spark Electrode (P/N: 32-508)

Installation Instructions

- 1 Disconnect electrical supply voltage to the heater.
- 2 Remove connections to electrode.
- 3 Replace old components with new, according to parts list.
- 4 Remove the 2 screws from the original electrode assembly to release from mounting bracket (Figure 1).
- 5 Install new electrode assembly.
- 6 Reconnect connections to spades.
- 7 Adjust spark electrode gap (Figures 2-3).

NOTE: A 1 inch clearance is required from the electrode to the rayhead rods. Snip the rod located closest to the electrode to obtain the proper clearance (Figure 1).

Chart 1 • Circuit Board Replacement Parts

Part No.	Description
MARK 10DX-117	120V Circuit Board
DRWH-120	Wiring harness for MARK 10DX-117
MARK 10DX-24	24V Circuit Board
DRWH-24	Wiring harness for MARK 10DX-24

Figure 1 • Electrode Mounting Bracket

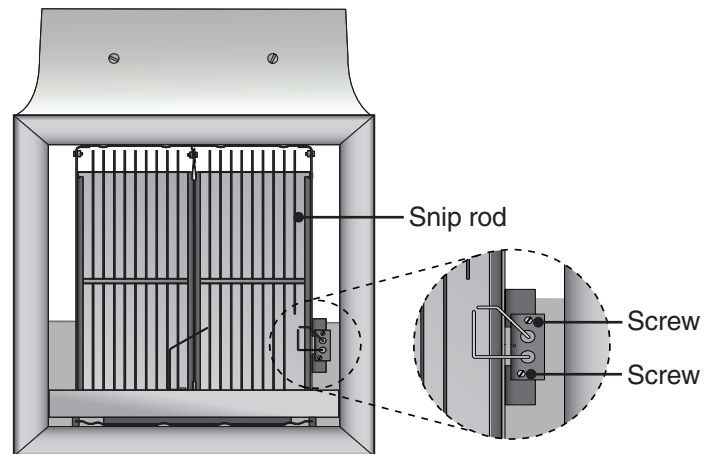

Figure 2 • Replacement 32-508 Electrode Side View

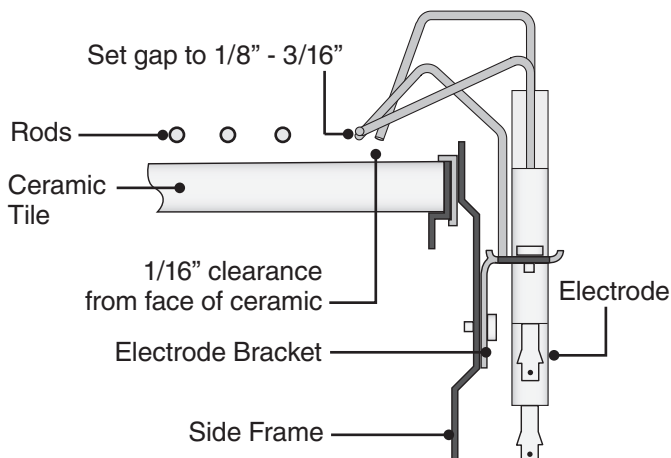

Figure 3 • Replacement 32-508 Electrode Top View

