

Data sheet

Actuators for modulating control

AME 120 NLX-1 - with position feedback signal

Description



The AME 120NLX-1 is a compact gear motor actuator that is assembled to 1/2" to 1-1/4" AB-QM valves sizes.

The actuator receives a modulating 0(2)-10VDC or 0(4)-20mA signal to provide precise control.

The profile of the actuator assembly is ideal in fan coil units, induction units, small reheaters, recoolers and zone applications in which hot/ chilled water is the controlled medium.

Main data:



- Position feedback or output signal (X=0-10 VDC)
- Gap detection at stem up position
- Modulating control
- Force switch-off at stem down position prevents overload of actuator and valve.
- No tools required for mounting
- Maintenance-free lifetime
- Last state position. Detection of missing control signal in 2-10V/4-20mA mode
- Low-noise operation
- Self-positioning process
- In accordance with UL 2043 for plenum installation

Ordering

Type	Supply voltage	Speed	Code No.
AME 120 NLX-1	24 V~	10 s/mm @ 60 Hz 12 s/mm @ 50 Hz	082H5004

Technical data

Power supply	V	24 ±20 %; AC	
Power consumption	running	VA	1.5
	standby	W	0.4
Frequency	Hz	50/60	
Control input Y	V	0-10 (2-10) Ri = 200 kΩ	
	mA	0-20 (4-20) Ri = 500 Ω	
Control output X	VDC	0-10 Ro _(min) = 38 kΩ	
Actuator Force	lbf (N)	29.2 (130)	
Max. Stem Travel	mm	5	
Speed	s/mm	10 s/mm @ 60 Hz 12 s/mm @ 50 Hz	
Max. medium temperature		248 (120)	
Ambient temperature	°F (°C)	32... + 131 (0... + 55)	
Storage and transport temperature		-40...+158 (-40...+70)	
Ambient humidity		95% r.h., non-condensing	
Protection class		Class 2 (North America) or Safety Extra-Low Voltage (SELV) (Europe)	
Grade of enclosure		Type 1, IP42	
Weight	lbs (kg)	0.67 (0.3)	

	USA	UL Listed, CCN XABE, File E480529; to ANSI/UL 60730-1 and ANSI/UL 60730-2-14 Investigated and approved for plenum use in accordance with UL 2043
	Canada	UL listed, CCN XABE7, File E48029; to CAN/CSA-E60730-1:13 and CAN/CSA-E60730-2-14:13
	Europe	CE Mark - Danfoss declares that this product complies with all relevant CE-marking directives

Installation

Mechanical

The actuator should be mounted with the valve stem in either horizontal position or pointing upwards.

Installation of the actuator assembly is certified for placement within the plenum airspace.

Electrical

Important: Prior to energizing the actuator should be assembled to the AB-QM.

Auto sleep mode

1. If actuator AME 120 NLX-1 is powered by 24 V supply voltage and if it is not installed on AB-QM valve, it will stop in lower position and switch off all LED indicators after 5 minutes.
2. **It is mandatory to drive the spindle of the actuator to upper position before it will be installed on AB-QM valve (please refer to manual override drawings)!**

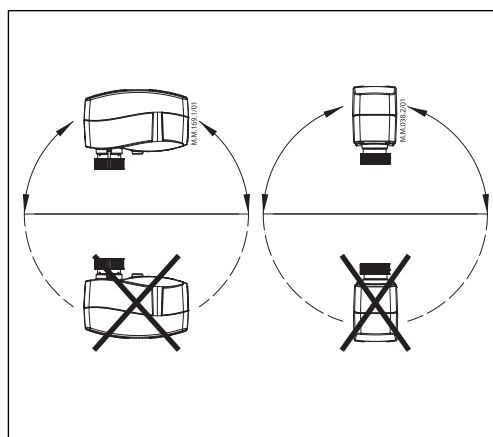

3. Auto sleep mode switches back to learning mode by pressing RESET button or by cycling power supply.

Installation procedure

1. Check the valve neck. The actuator should be in the full up position (factory setting). If it is not, manually reposition the actuator to its full up position.
2. The actuator is fixed to the valve body by means of a ribbed nut which requires no tools for mounting. The ribbed nut should be hand tightened only.
3. For applications requiring conduit, a field supplied 1/2" trade size electrician's fitting and lock nut can mounted in the actuator enclosure. Make all wiring connections in accordance with local, national, or regional regulations.
4. Insert wiring material through the removable plug or conduit fitting, and connect to the terminal block according to the wiring diagram.

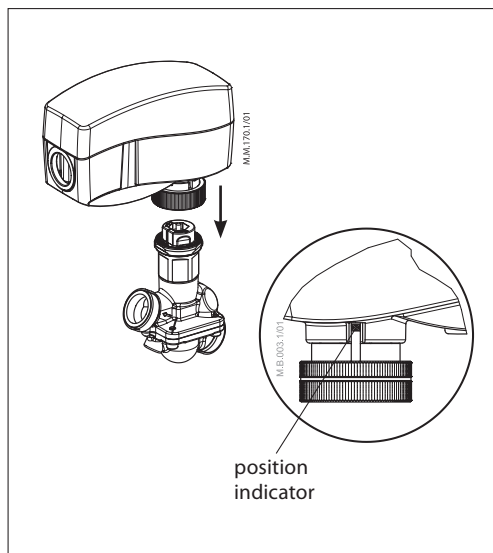

Wiring

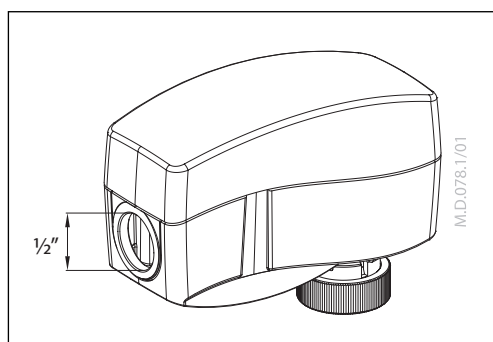
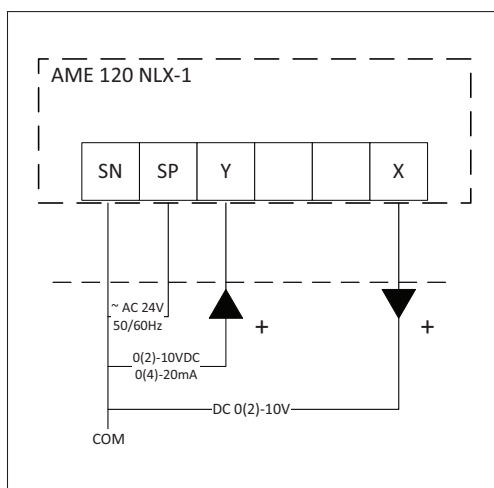

A field supplied 1/2" trade size electrician's fitting and lock nut can be mounted to the actuator enclosure. Insert wiring material through the removable plug or conduit fitting, and wire connection to the terminal block.

Commissioning

The factory position of the actuator spindle is in a full stem up position allowing easier mechanical connection of the actuator on the valve.

DIP Switch Setting
(for service purposes only)

The actuator has a function selection DIP switch under the removable cover.

The switch provides the following functions:

- SW1:
0/2 - Input signal range selector
If set to OFF position, the input signal is in the range from 2-10 V (voltage input) or from 4-20 mA (current input).
In case of missing control signal, during normal operation in 2-10V/4-20mA mode (OFF position), the actuator will stay in the last known position, until a valid control signal is present again. If set to ON position, the input signal is in the range from 0-10 V (voltage input) or from 0-20 mA (current input).
- SW2:
D/I - Direct or inverse acting selector
If set to OFF position, the actuator is direct acting (stem contracts as voltage increases). If the actuator is set to ON position, the actuator is inverse acting (stem extracts as voltage increases).
- SW3:
---/Seq - Normal or sequential mode selector:
If set to OFF position, the actuator is working in range 0(2)-10 V or 0(4)-20 mA.
If set to ON position, the actuator is working in sequential range; 0(2)-5(6) V or (0(4)-10(12) mA) or (5(6)-10 V) or (10(12)-20 mA).

- SW4:
0-5 V/5-10 V - Input signal range in sequential mode:
If set to OFF position, the actuator is working in sequential range 0(2)-5(6) V or 0(4)-10(12) mA.
If set to ON position, the actuator is working in sequential range; 5(6)-10 V or 10(12)-20 mA.
- SW5:
LIN/LOG - Linear or equal percentage flow through valve selector
If set to OFF position, the flow through the valve is equal percentage-wise equals the control signal.
If set to ON position, the flow through the valve is linear in accordance to the control signal.
- SW6:
---/ASTK - Anti-blocking function
Exercises the valve to avoid blocking in periods when the heating/cooling is off.
If set to ON position (ASTK), the valve motion is switched on. The actuator opens and closes the valve every 7 days.
If set to OFF position (---), the function is disabled.
- SW7:
U/I - Input signal type selector
If set to OFF position, voltage input is selected. If set to ON position, current input is selected.

Note:
The reset button ① will cause the actuator to go through a self stroking cycle (press it for 2 s).
Remark:
When the manual override has been used, the output signal (X) is not correct until the actuator reaches its end position.

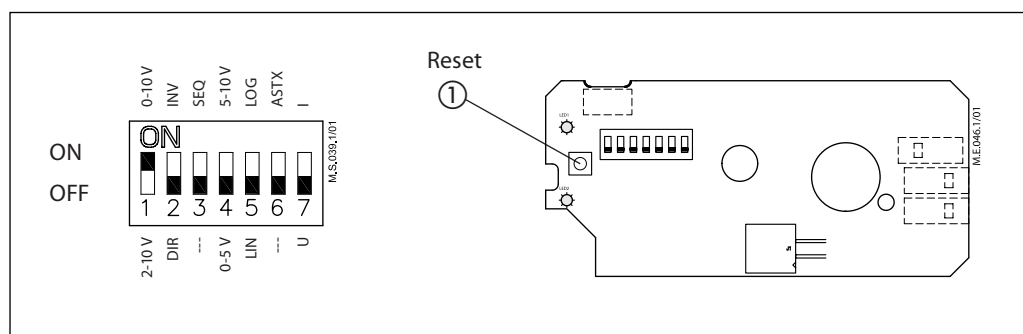

Disposal

The actuator must be dismantled and the elements sorted into various material groups before disposal.

Manual override (for service purposes only)

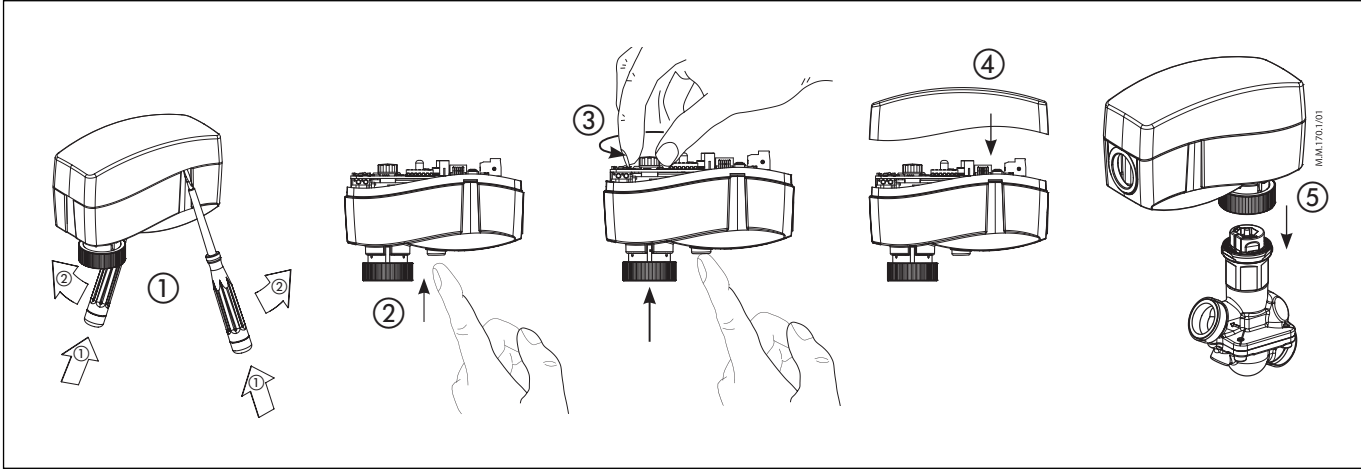

Caution:
Do not manually operate the drive if power is connected!

Do not dismantle the actuator from the valve when it is in a stem down position!
If dismantled in a stem down position, there is a risk that the actuator will seize.

- Remove cover ①
- Press and hold the button ② (on the bottom side of the actuator) during manual override ③
- Replace cover ④
- Install actuator on valve ⑤

Remark:
A 'click' sound after energising the actuator indicates that the gear wheel has jumped into normal position.

If manual override has been used, the Y signal will not be correct until the actuator has reached its end position. If this is not accepted, reset the actuator.

Dimensions

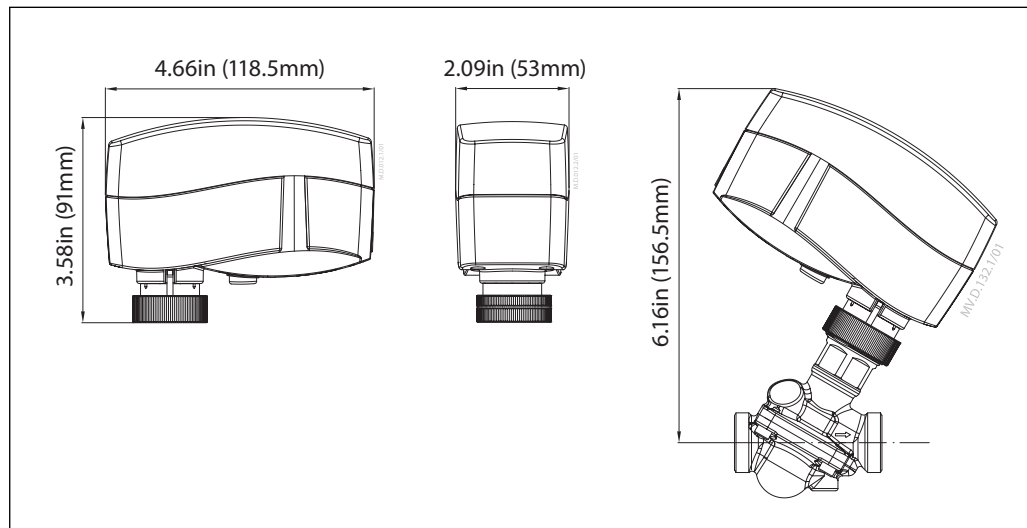

Danfoss A/S
Heating Segment • heating.danfoss.com • +45 7488 2222 • E-Mail: heating@danfoss.com

Danfoss can accept no responsibility for possible errors in catalogues, brochures and other printed material. Danfoss reserves the right to alter its products without notice. This also applies to products already on order provided that such alterations can be made without subsequential changes being necessary in specifications already agreed. All trademarks in this material are property of the respective companies. Danfoss and all Danfoss logotypes are trademarks of Danfoss A/S. All rights reserved.