

## DVK DRYER BOOSTER FAN



The DVK Dryer Booster Fan is designed to enhance the drying efficiency of a dryer. It is capable of overcoming a long duct run, and the in-line design simplifies installation. Unique features result in a quiet and powerful dryer boosting solution.

### Features & Benefits

- Boost dryer exhaust efficiency, reduce drying times, and deliver cost savings
- External rotor motor design for quiet and efficient operation
- Backward-curved centrifugal impeller to overcome long duct runs
- In-line construction to reduce lint build-up
- Heavy gauge, drawn steel housing with baked epoxy finish
- High temperature construction: 60 C/140 F
- Thermal overload protection
- Automatic reset

### Installation Tips

- DVK100B fans should be mounted at least 15 linear feet from dryer.
- Each 90-degree elbow is equivalent to 5 linear feet of duct.
- DVK100B fans are designed to vent up to 110 feet of 4-inch rigid duct.

### Controls & Accessories ~ pages 24-25

MODEL	WATTS	RPM	AIRFLOW PERFORMANCE (CFM)							
			0" SP	0.2" SP	0.4" SP	0.6" SP	0.8" SP	1.0" SP	1.2" SP	1.5" SP
DVK100B	83.4	2620	150	140	127	112	94	74	53	23

MODEL	DIMENSIONS IN INCHES*				SHIP WT (lbs)
	ØD	Ød	A	B	
DVK100B	9.5	3.9	1.0	8.3	8.0

\*DO NOT USE FOR CONSTRUCTION CONSULT FACTORY FOR CERTIFIED PRINTS

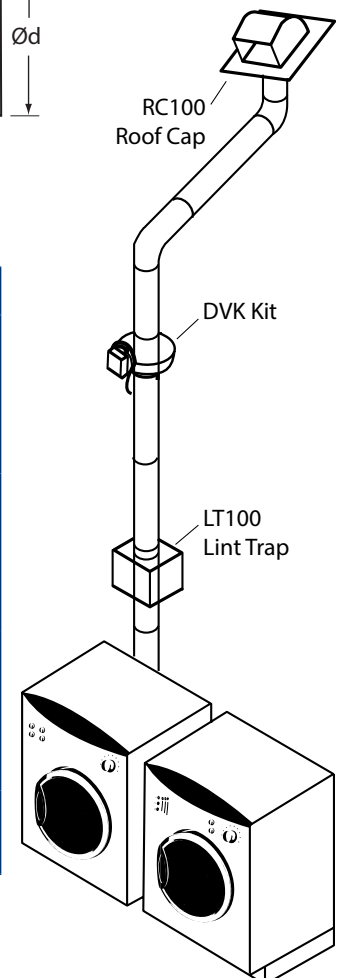
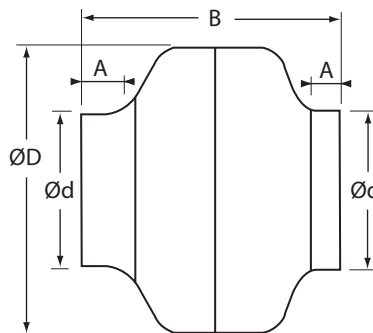

### BOOSTER FAN ACTIVATION METHODS



#### Current Sensor (DVK100B-C Kit)

This is the preferred method for activating a dryer booster fan. When a clothes dryer is operating and drawing at least one amp of current, the current sensor automatically activates the DVK100B dryer booster fan.



#### Pressure Switch (DVK100B-P Kit)

The pressure switch is designed to be mounted in the duct between the fan and the dryer. When it senses dryer airflow, the switch activates the DVK100B dryer booster fan.



#### Pressure Switch - Mounted (DVK100B-PM Kit)

The pre-mounted pressure switch simplifies installation. Utilizing the components found in the DVK100B-P kit, the pressure switch is pre-wired and factory mounted to the DVK100B dryer booster fan.

Each of the above booster fan activation methods may be purchased as a separate accessory item. Note: Continental Fan does not recommend wiring a dryer booster fan directly into a clothes dryer.

### Helpful Hints

A LT100 Lint Trap may be installed between the dryer and the booster fan to reduce lint build-up and maintenance on the fan.

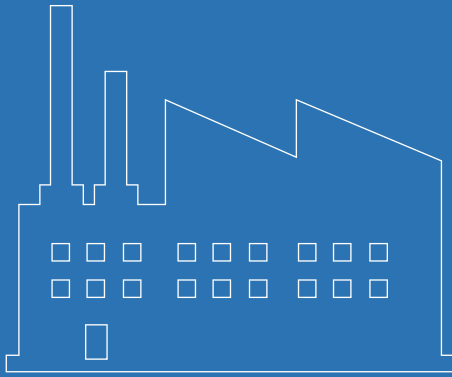

***Industrial Fans  
& Blowers***

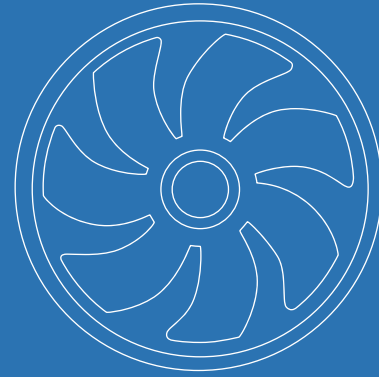

***OEM Solutions  
& Custom Fans***



***Commercial Fans  
& Dampers***



***Residential Fans &  
Air Purifiers***



# Wholesale Ventilation Products

Continental Fan Manufacturing Inc.  
Buffalo, NY ~ Dayton, OH

Continental Fan Canada Inc.  
Mississauga, ON

[www.continentalfan.com](http://www.continentalfan.com)  
1-800-779-4021

Distributed by:

