

V Vertical Convection Heater

- 2 - 4.5 kW
- 6,824 - 15,354 Btuh
- 120, 240 and 480 Volt
- Single Phase

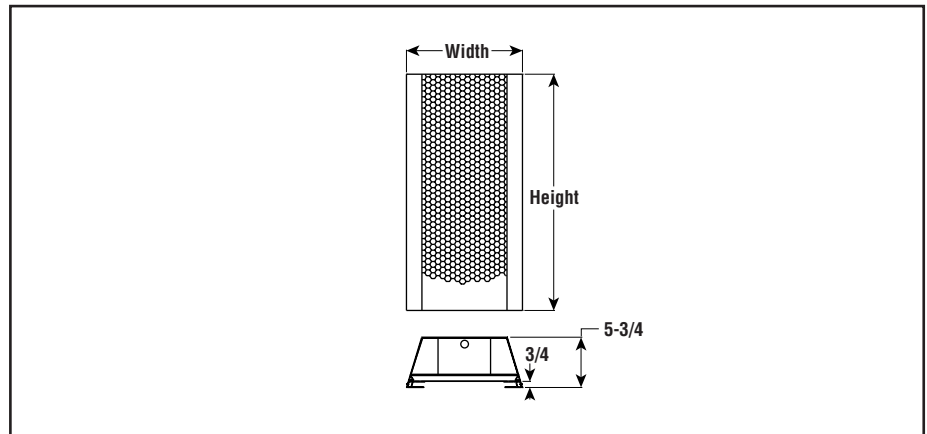

Dimensions (Inches)



Description

Type V vertical convection heaters are designed for the highest dependability for rugged plant areas and small manned or unattended areas.

Applications

- Crane Cabs
- Shop Offices
- Small Plant Areas
- Non-Hazardous Pump Sheds

Construction

Cabinet — Heavy gauge perforated steel case finished in corrosion resistant black polyester powder coat paint.

Heating Elements are strip type construction and are the most rugged, durable, long-lasting elements available to industry.

CAUTION — Not intended for use where flammable vapors, gases, liquids or other combustible atmospheres are present.

Advantages

- Long Life
- Durable for High Traffic Areas
- Easy Installation
- Corrosion Resistant
- Low Maintenance

Specifications and Ordering Information

kW	Volts	No. Elem.	Amps	Btuh	Dimensions (In.)			Model	Stock	PCN	Wt. (Lbs.)
					Height	Width	Depth				
2	240	4	8.3	6,824	27	12-3/4	5-3/4	V-2020	NS	262254	34
3	240	4	12.5	10,236	27	12-3/4	5-3/4	V-2030	S	262318	34
3	480	4	6.3	10,236	27	12-3/4	5-3/4	V-2030	NS	262326	34
4.5	120	6	25	10,236	27	17-3/4	5-3/4	V-2040	NS	262369	44
4.5	240	6	18.8	15,354	27	17-3/4	5-3/4	V-2040	S	262377	44
4.5	480	6	9.4	15,354	27	17-3/4	5-3/4	V-2040	S	262385	44

Stock Status: S = stock AS = assembly stock NS = non-stock
To Order—Specify model, PCN, kW, volts, phase and quantity.

Refer to
WR-80, WR-90
in the Controls section.