

Chromalox®

Installation, Operation and **RENEWAL PARTS IDENTIFICATION**

SERVICE REFERENCE

DIVISION 4	SECTION
SALES REFERENCE (Supersedes PG436)	PG436-1
	161-304901-004
DATE	JULY, 2003

DS-50600, STAR-GF, STAR-TIP and STAR-TG Kits **For Adding Optional Kits to STAR Radiant Heaters**



Model DS50600



Model STAR-TIP
STAR-TG



STAR-GF

⚠ WARNING

ELECTRIC SHOCK HAZARD. Disconnect all power to heater before installing or servicing kit(s). Failure to do so could result in personal injury or property damage. Kit(s) must be installed by a qualified person in accordance with the National Electrical Code, NFPA 70.

Always check to make certain the voltage rating of the kit matches the voltage rating of the heater (See Nameplates).

GENERAL

To use this instruction sheet from Table 1 select the Installation Instructions by matching the Kit Model to the Heater Model. If a match does not exist consult Factory.

The kits are add-on options to STAR Radiant Heaters. The installation and renewal parts identification for the heater is covered in the instruction sheet provided with the heater. **SAVE BOTH COPIES OF THE INSTRUCTION SHEET.**

Table 1

Kit Model	Used with Heater Model	Kit Function	Installation Instructions	Wiring Diagram
DS-50600	Fixed STAR-06A and STAR-14A	Adds Integral Disconnect Switch	See Page 2	Fig. 1
DS-50600	Portable STAR-06A and STAR-14A	Adds Integral Disconnect Switch	See Page 3	Fig. 1
STAR-GF	All Fixed STAR	Adds Wall Mounted Ground Fault Sensor	See Page 4	Fig. 2
STAR-TIP	Portable STAR-06A and STAR-14A	Adds Tip Over Shut Down	See Page 5	Fig. 3
STAR-TG	Portable STAR-06A and STAR-14A	Adds Tip Over Shut Down with Ground Fault Sensor	See Pages 5 and 6	Fig. 4

INSTALLATION INSTRUCTIONS

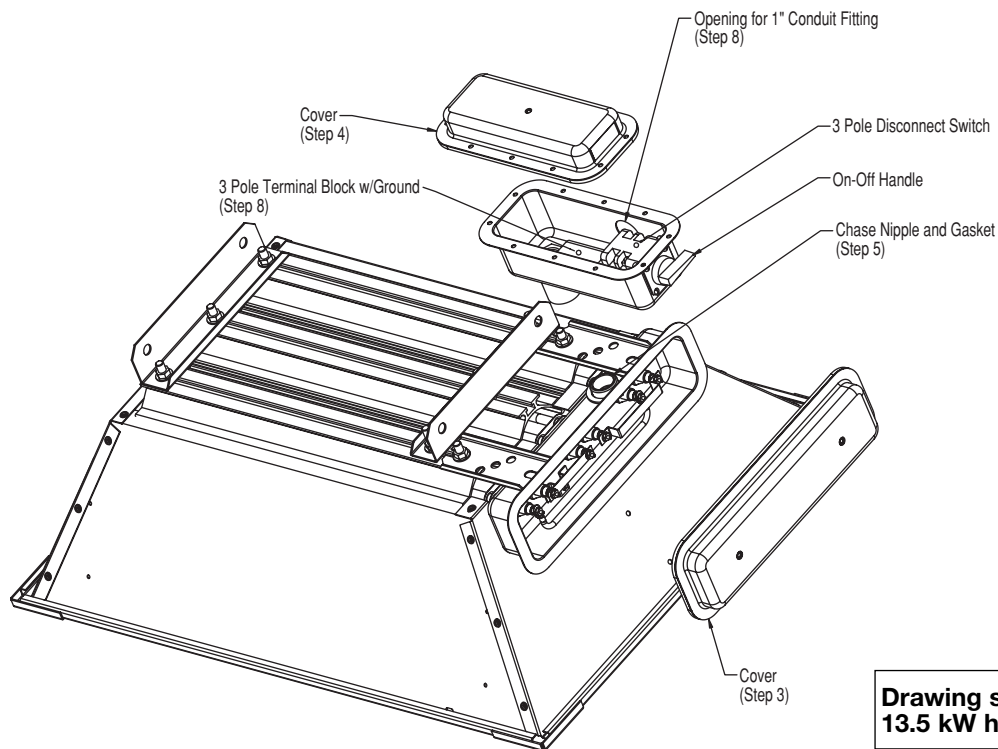

**Drawing shows 6 kW heater.
13.5 kW heater steps are identical.**

INSTRUCTIONS FOR INSTALLING DISCONNECT SWITCH ON 6 AND 13.5 KW FIXED RADIANT HEATERS

1. Addition of the disconnect switch assy must be done by a qualified electrician.
2. The disconnect switch kit includes the following parts.
Verify that all parts are included, if not, contact the Chromalox Service Dept.
 - (1) Disconnect Switch Assy
 - (2) Mounting Bracket (Not Used)
 - (3) Hardware Kit: (Not Used)
 - Two 3/8" Lockwashers
 - Two 3/8" Nuts
 - One Self Tapping Screw
 - One Gasket for Cord Fitting (Supplied Separately)
3. Remove the screws in the heater terminal box. Remove cover.
4. Remove cover from disconnect switch assy using same method as Step 3.
5. Remove Chase nipple and gasket from opening end of disconnect switch assy. Slide Chase nipple through hole in heater terminal box and then gasket over threads.
6. Thread Chase nipple into threaded coupling. Wrench tighten nipple.
7. Uncoil three (3) leads marked "1", "2", and "3" located in disconnect switch housing. Thread these three (3) leads through the nipple. Attach leads to the terminals indicated on the heater wiring label located on the cover of the heater. If using for single phase, cap off lead marked "3".
8. Attach conduit to the opening in the disconnect switch housing. Connect leads to terminal block.
9. Inspect all wiring to make sure all connections are tight, adequate electrical clearances exist, and all electrical practices are met.
10. Install both covers.

INSTALLATION INSTRUCTIONS

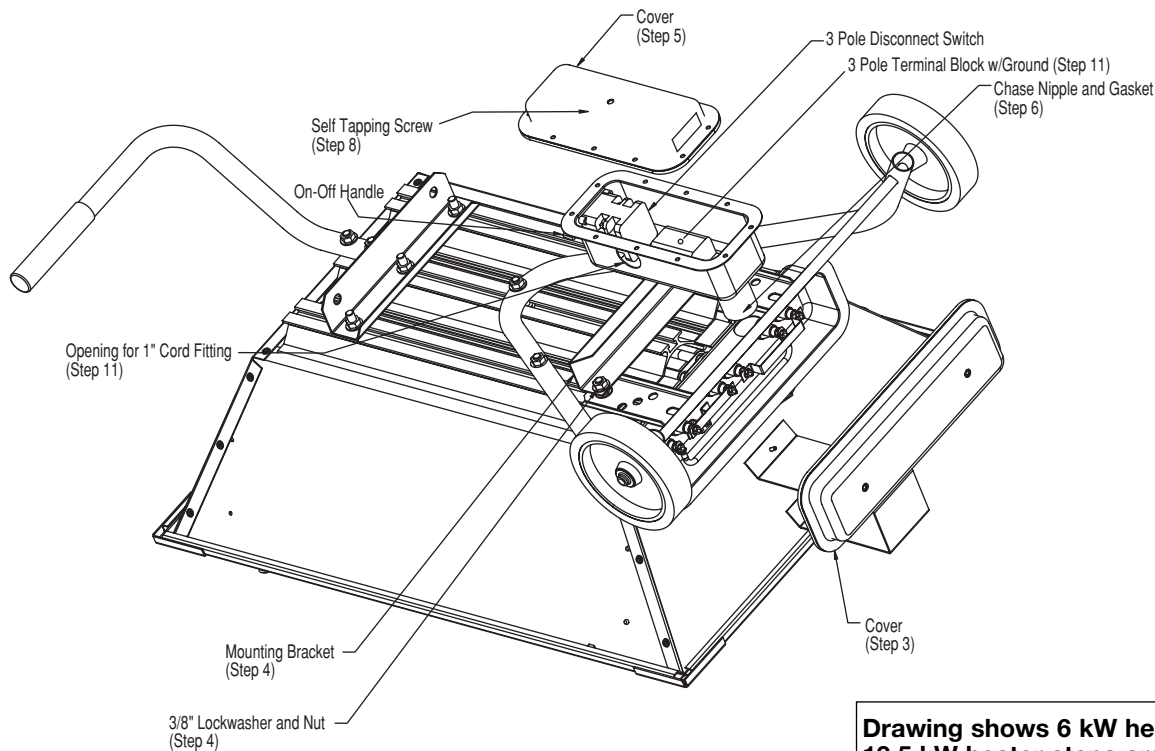

INSTRUCTIONS FOR INSTALLING DISCONNECT SWITCH ON 6 AND 13.5 KW PORTABLE RADIANT HEATERS

1. Addition of the disconnect switch assy must be done by a qualified electrician.
2. The disconnect switch kit includes the following parts.
Verify that all parts are included, if not, contact the Chromalox Service Dept.
 - (1) Disconnect Switch Assy
 - (2) Mounting Bracket
 - (3) Hardware Kit:
 - Two 3/8" Lockwashers
 - Two 3/8" Nuts
 - One Self Tapping Screw
 - One Gasket for Cord Fitting (Supplied Separately)
3. Remove the screws in the heater terminal box. Remove cover.
4. Place mounting bracket over 3/8" studs as shown. Place lockwashers on studs and secure in place with 3/8" nuts.
5. Remove cover from disconnect switch assy using same method as Step 3.
6. Remove Chase nipple and gasket from opening end of disconnect switch assy. Slide Chase nipple through hole in heater terminal box and then gasket over threads.
7. Thread Chase nipple into threaded coupling. Hand tighten only.
8. Line up hole in bottom of disconnect switch housing with hole in mounting bracket. Tap 10-32 x 1/2" long screw into mounting bracket.
9. Wrench tighten Chase nipple installed in Step 6.
10. Uncoil three (3) leads marked "1", "2", and "3" located in disconnect switch housing. Thread these three (3) leads through the nipple. Attach leads to the terminals indicated on the heater wiring label located on the cover of the heater. If using for single phase, cap off lead marked "3".
11. Attach cord assy to the opening in the disconnect switch housing. Connect leads of cord to terminal block.
12. Inspect all wiring to make sure all connections are tight, adequate electrical clearances exist, and all electrical practices are met.
13. Install both covers.

INSTRUCTIONS FOR INSTALLING WALL MOUNTED STAR-GF

1. Check voltage on heater nameplate and STAR-GF to make certain voltages are the same. If voltages do not match, consult factory.
2. The STAR-GF will provide ground fault protection for STAR Radiant heaters. The number of heaters serviced by one (1) STAR-GF is dependent on the number and length of the heating elements. See Table 2.
3. See Instruction Sheet PG434 (provided with heater) for IMPORTANT INSTRUCTIONS and WIRING.
4. Using the STAR-GF as a template mark mounting holes on wall. Use an anchoring method adequate to support the weight.
5. Wire between STAR-GF and heater, wire to terminal block. Service entrance wiring to be made to contactor connectors. For wire gage see Table 1 of PG434.
6. The ground fault sensor has been factory set at .03 Amps, **DO NOT CHANGE THE SETTING.**

STAR-GF Mounting Dimensions

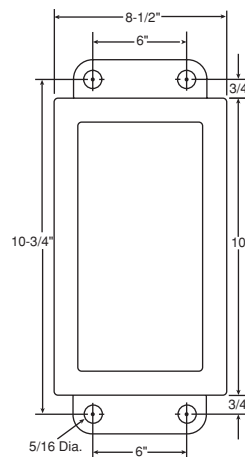

Table 2

Heater Model	Max. No. of Heaters
STAR-02A	6
STAR-05A	3
STAR-06A	2
STAR-14A	1

MAINTENANCE

The Chromalox STAR-GF ground fault sensor provides a reliable and cost effective method for sensing ground faults. The purpose is to monitor for ground faults, sense potential heater failure symptoms and to protect equipment.

The current-carrying wires are routed through the current transformer on the control. When ground current reaches the level set by the trip point adjustment, (.03 Amps), the relay trips, illuminates the tripped LED and provides an output signal which de-energizes the magnetic contactor.

Failure to do so could result in personal injury or property damage. Kit(s) must be installed by a qualified person in accordance with the National Electrical Code, NFPA 70.

If heating element(s) fail to operate:

1. Open door of enclosure. **DANGER: Hazard of Electric Shock.** If "Tripped" indicator is on, this indicates one or more heating elements are about to fail. Disconnect power and follow the GF Troubleshooting Diagram below.
2. If the "Tripped" indicator is not on, check for blown fuses or failed components within the heater's electrical system.

⚠ WARNING

ELECTRIC SHOCK HAZARD. Disconnect all power to heater before installing or servicing kit(s).

GF TROUBLESHOOTING DIAGRAM

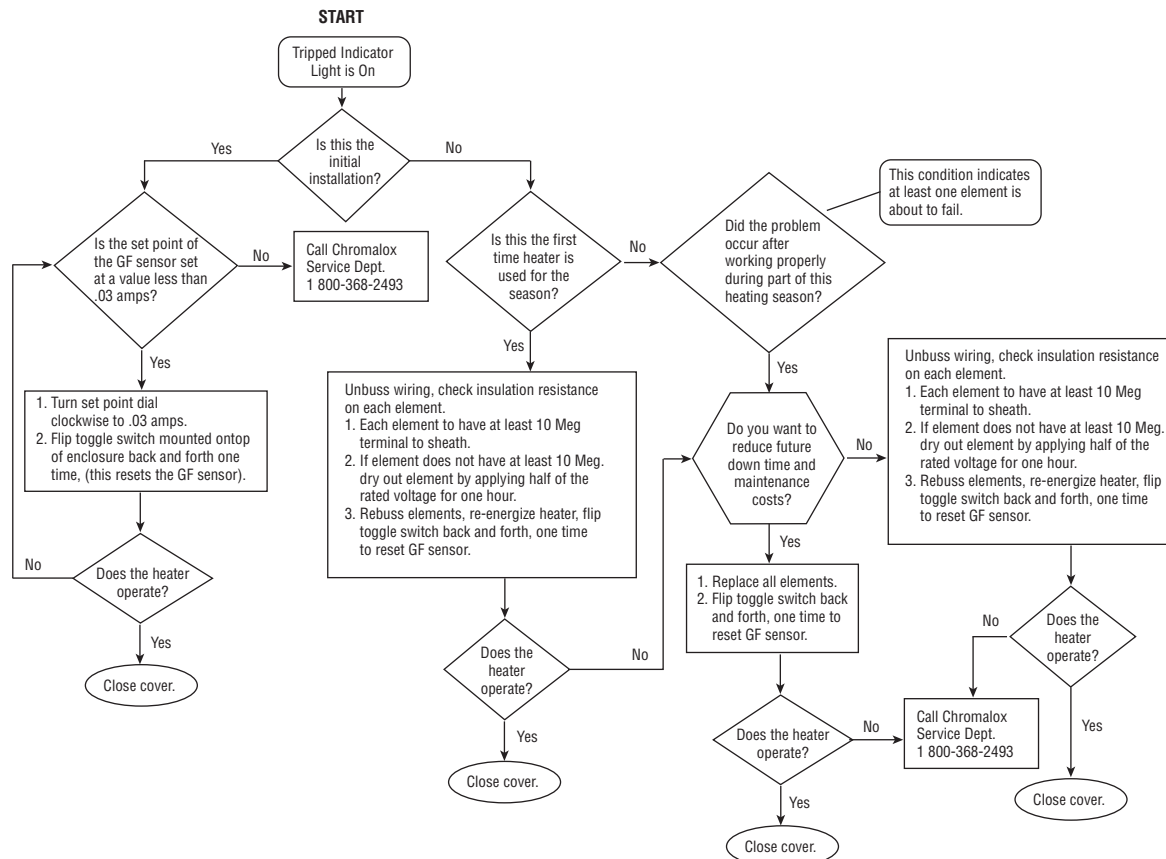

INSTALLATION INSTRUCTIONS

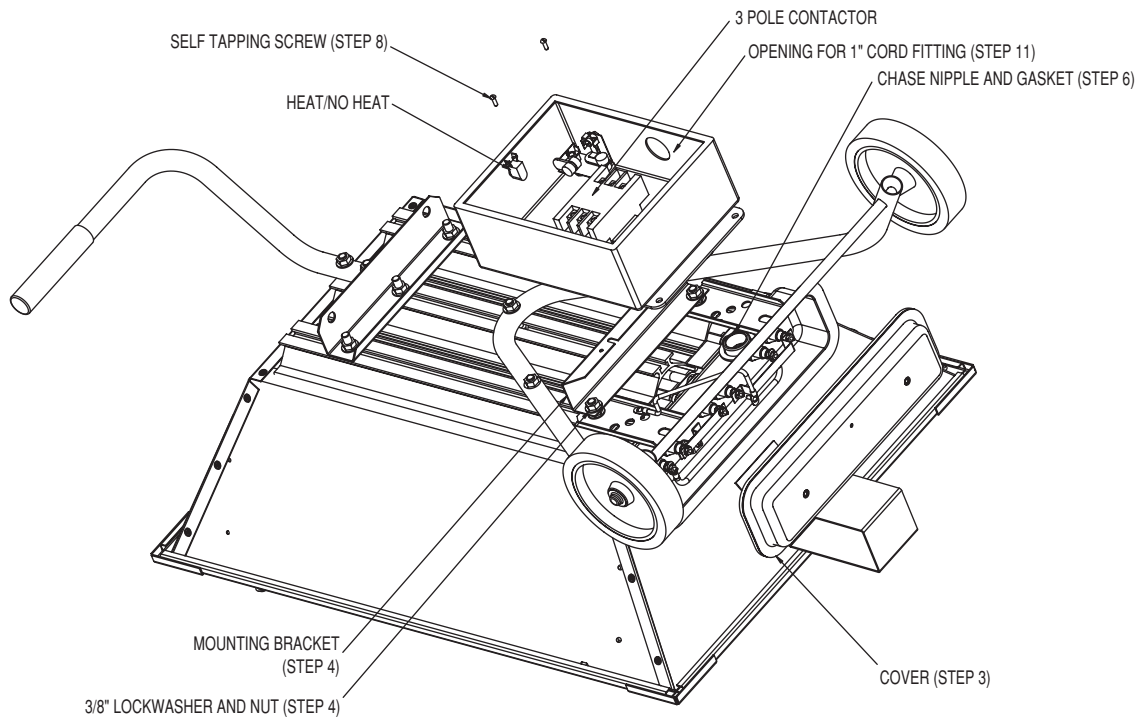

VIEW SHOWN WITH TIP OVER SWITCH ASSY COVER REMOVED

**Drawing shows 6 kW heater.
13.5 kW heater steps are identical.**

INSTRUCTIONS FOR INSTALLING "STAR-TIP" AND "STAR-TG" ON 6 AND 13.5 KW PORTABLE RADIANT HEATERS

1. Addition of the tip over switch assy must be done by a qualified electrician.
2. The tip over switch assy includes the following parts.
Verify that all parts are included, if not, contact the Chromalox Service Dept.
(1) Tip Over Switch Assy
(2) Mounting Bracket
(3) Hardware Kit:
Two 3/8" Lockwashers
Two 3/8" Nuts
Two Self Tapping Screw
One Gasket for Cord Fitting (Supplied Separately)
3. Remove the screws in the heater terminal box. Remove cover.
4. Place mounting bracket over 3/8" studs as shown. Place lockwashers on studs and secure in place with 3/8" nuts.
5. Remove cover from tip over switch assy using same method as Step 3.
6. Remove Chase nipple and gasket from open end of tip over switch assy. Slide Chase nipple through hole in heater terminal box and then gasket over threads.
7. Thread Chase nipple into threaded coupling. Hand tighten nipple.
8. Line up hole in bottom of tip over switch with hole in mounting bracket. Tap 10-32 x 1/2" long screws into mounting bracket.
9. Wrench tightened Chase nipple installed in Step 6.
10. Uncoil three (3) leads marked "1", "2", and "3" located in disconnect switch housing. Thread these three (3) leads through the nipple. Wire nut leads of tip over switch to leads of heater. If using for single phase, cap off lead marked "3".
11. Attach cord assembly to the opening in the tip over switch housing. Connect leads of cord to the contactor.
12. Inspect all wiring to make sure all connections are tight, adequate electrical clearances exist, and all electrical practices are met.
13. Install both covers.

MAINTENANCE

The Chromalox STAR-TG tip over cutout with ground fault sensor provides a reliable and cost effective method for sensing ground faults and to shut off the heater in case of tip-over. The purpose of the ground fault control is to monitor for ground faults, sense potential heater failure symptoms and to protect equipment.

The current-carrying wires are routed through the current transformer on the control. When ground current reaches the level set by the trip point adjustment, (.03 amps), the relay trips, illuminates the tripped LED and provides an output signal which de-energizes the magnetic contactor.

⚠ WARNING

ELECTRIC SHOCK HAZARD. Disconnect all power to heater before installing or servicing kit(s).

Failure to do so could result in personal injury or property damage. Kit(s) must be installed by a qualified person in accordance with the National Electrical Code, NFPA 70.

If heating element(s) fail to operate:

1. Open door of enclosure. **DANGER: Hazard of Electric Shock.**
2. If "Tripped" indicator is not on, check for blown fuses or failed electrical components in the heater's electrical system including the tip over trip mechanism. then this indicates one or more heating elements are about to fail.
3. Check pendulums on the tip over switch mechanisms to be sure they are not blocked.
4. If the "Tripped" indicator is on, then this indicates one or more heating elements are about to fail. Disconnect power and follow the GF Troubleshooting Diagram below.

TG TROUBLESHOOTING DIAGRAM

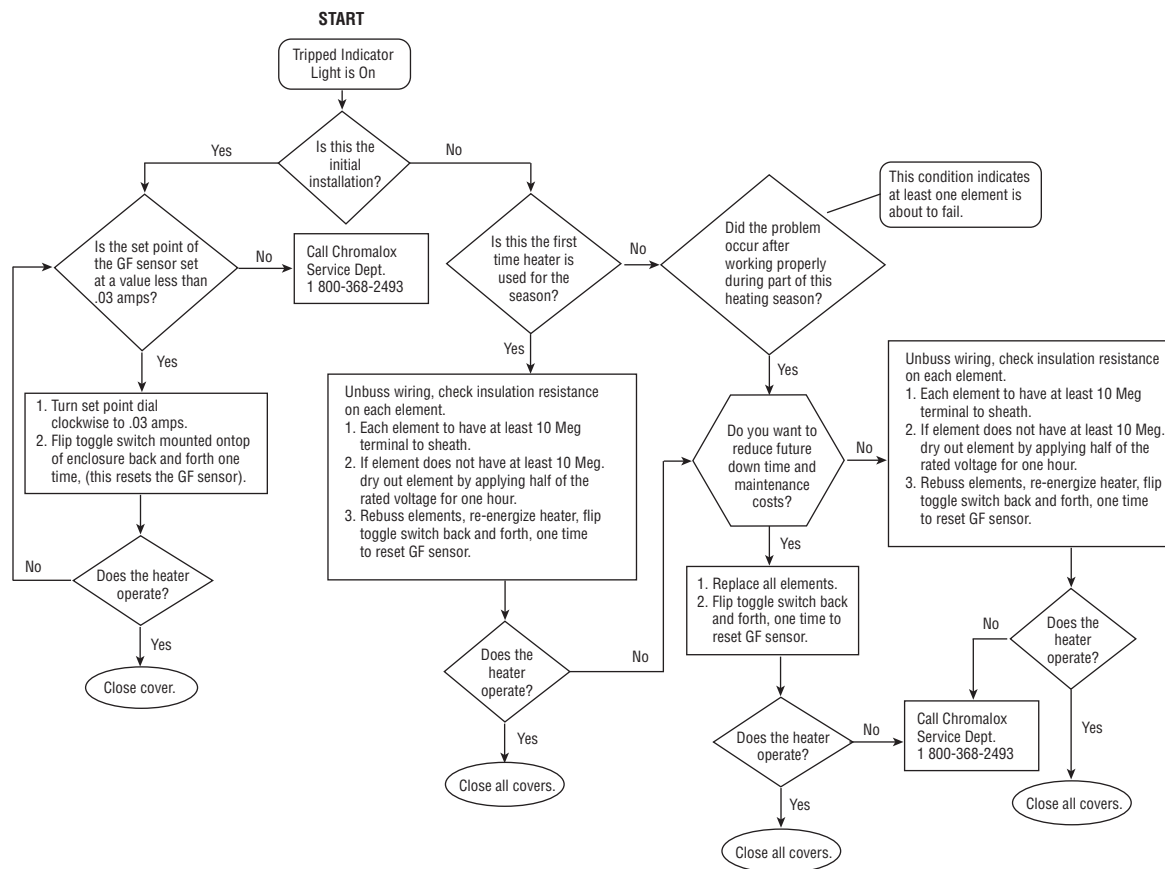

WIRING

For applicable wiring diagram see Table 1

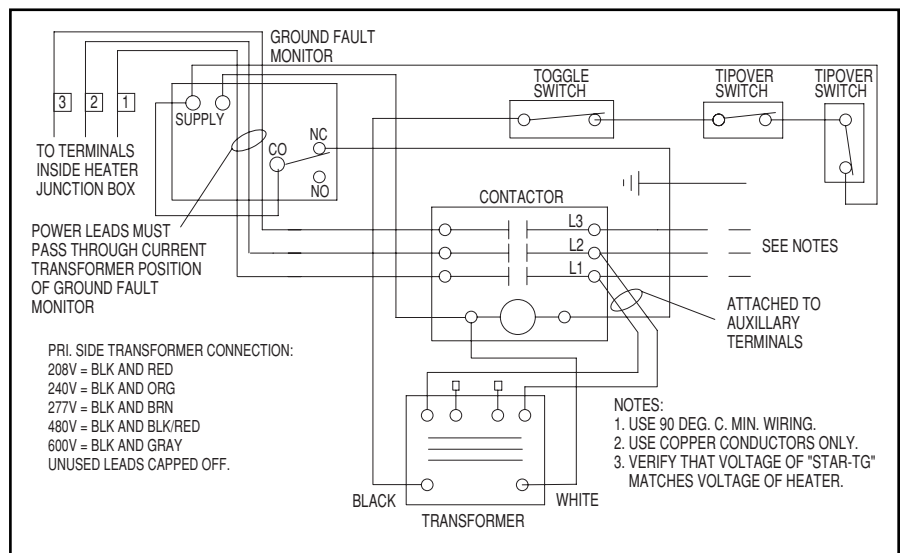
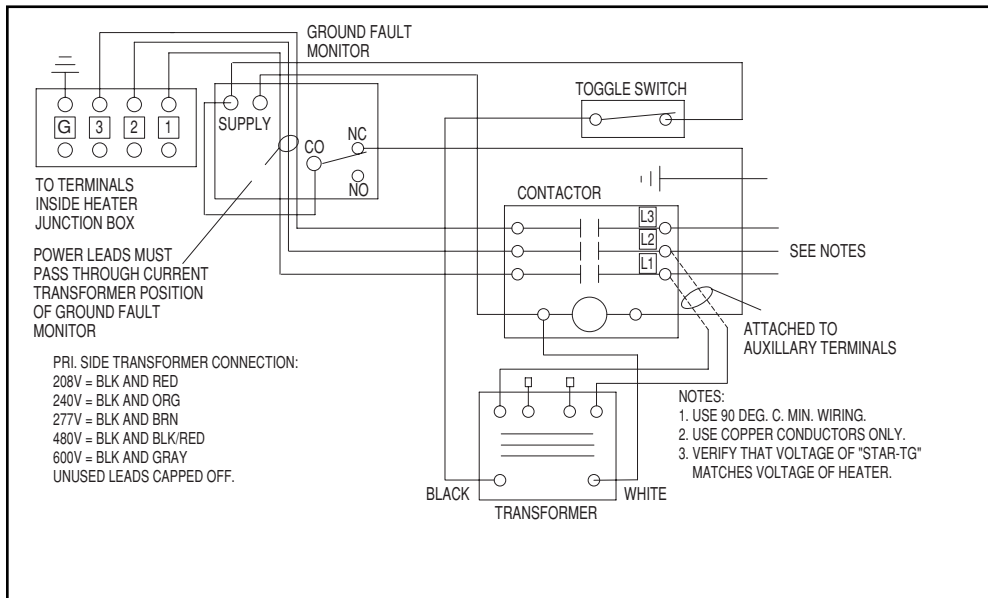
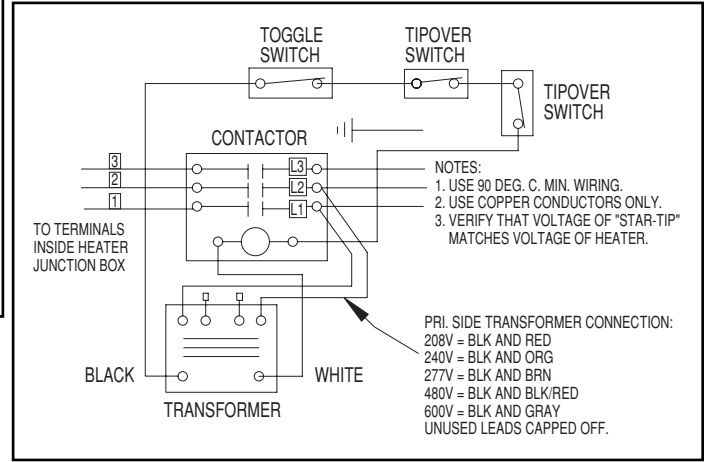
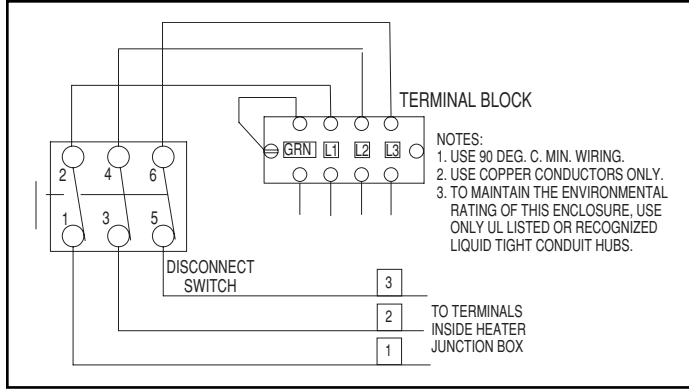

RENEWAL PARTS IDENTIFICATION

Kit Model	Disconnect Switch	DS Shaft Gasket	Cover Gasket	"U" Shaped Clamp	Term. Block Cont. Sect.	Term. Block End. Sect.	Toggle Switch	Toggle Switch Boot	Contactors	Ground Fault Sensor	Tip Over Switch
DS-506008	292-303472-007	132-304689-001	132-304879-002	056-304884-004			NA	NA	NA	NA	NA
STAR-GF-8											
STAR-GF-3											
STAR-GF-4											
STAR-GF-7											
STAR-GF-6											
STAR-TIP-8											
STAR-TIP-2	NA	NA	NA	NA	303-052241-002	303-052241-001	292-046123-001	024-052539-001	072-304551-008	072-121851-062	292-304695-001
STAR-TIP-4											
STAR-TIP-7											
STAR-TIP-6											
STAR-TG-8											
STAR-TG-2											
STAR-TG-4											
STAR-TG-7											
STAR-TG-6											

WARRANTY AND LIMITATION OF REMEDY AND LIABILITY

Chromalox warrants only that the Products and parts manufactured by Chromalox, when shipped, and the work performed by Chromalox when performed, will meet all applicable specification and other specific product and work requirements (including those of performance), if any, and will be free from defects in material and workmanship under normal conditions of use. All claims for defective or nonconforming (both hereinafter called defective) Products, parts or work under this warranty must be made in writing immediately upon discovery, and in any event, within one (1) year from delivery, provided, however all claims for defective Products and parts must be made in writing no later than eighteen (18) months after shipment by Chromalox. Defective and nonconforming items must be held for Chromalox's inspections and returned to the original f.o.b. point upon request. THE FOREGOING IS EXPRESSLY IN LIEU OF ALL OTHER WARRANTIES WHATSOEVER, EXPRESS, IMPLIED AND STATUTORY, INCLUDING, WITHOUT LIMITATION, THE IMPLIED WARRANTIES OF MERCHANTABILITY AND FITNESS FOR A PARTICULAR PURPOSE.

Notwithstanding the provisions of this WARRANTY AND LIMITATION Clause, it is specifically understood that Products and parts not manufactured and work not performed by Chromalox are warranted only to the extent and in the manner that the same are warranted to Chromalox by Chromalox's vendors, and then only to the extent that Chromalox is reasonably able to enforce such warranty, it being understood Chromalox shall have no obligation to initiate litigation unless Buyer undertakes to pay all cost and expenses therefor, including but not limited to attorney's fees, and indemnifies Chromalox against any liability to Chromalox's

vendors arising out of such litigation.

Upon Buyer's submission of a claim as provided above and its substantiation, Chromalox shall at its option either (i) repair or replace its Products, parts or work at the original f.o.b. point of delivery or (ii) refund an equitable portion of the purchase price.

THE FOREGOING IS CHROMALOX'S ONLY OBLIGATION AND BUYER'S EXCLUSIVE REMEDY FOR BREACH OF WARRANTY, AND IS BUYER'S EXCLUSIVE REMEDY AGAINST CHROMALOX FOR ALL CLAIMS ARISING HEREUNDER OR RELATING HERETO WHETHER SUCH CLAIMS ARE BASED ON BREACH OF CONTRACT, TORT (INCLUDING NEGLIGENCE AND STRICT LIABILITY) OR OTHER THEORIES, BUYER'S FAILURE TO SUBMIT A CLAIM AS PROVIDED ABOVE SHALL SPECIFICALLY WAIVE ALL CLAIMS FOR DAMAGES OR OTHER RELIEF, INCLUDING BUT NOT LIMITED TO CLAIMS BASED ON LATENT DEFECTS. IN NO EVENT SHALL BUYER BE ENTITLED TO INCIDENTAL OR CONSEQUENTIAL DAMAGES AND BUYER SHALL HOLD CHROMALOX HARMLESS THEREFROM. ANY ACTION BY BUYER ARISING HEREUNDER OR RELATING HERETO, WHETHER BASED ON BREACH OF CONTRACT, TORT (INCLUDING NEGLIGENCE AND STRICT LIABILITY) OR OTHER THEORIES, MUST BE COMMENCED WITHIN ONE (1) YEAR AFTER THE DATE OF SHIPMENT OR IT SHALL BE BARRED.

W2008M

Chromalox®

PRECISION HEAT AND CONTROL

2150 N. RULON WHITE BLVD., OGDEN, UT 84404
Phone: 1-800-368-2493 www.chromalox.com