

# Chromalox®

## Installation, Operation and RENEWAL PARTS IDENTIFICATION

### SERVICE REFERENCE

DIVISION 4	SECTION
SALES REFERENCE (Supersedes PG434-1)	PG434-2
161-304901-002	
DATE JULY, 2003	

## Type STAR Radiant Heater For Fixed Overhead Installations

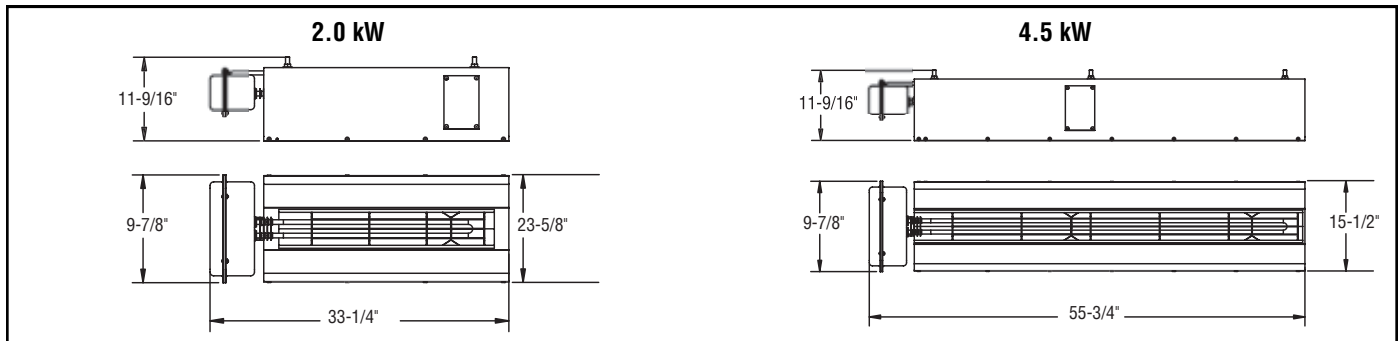

Figure 1

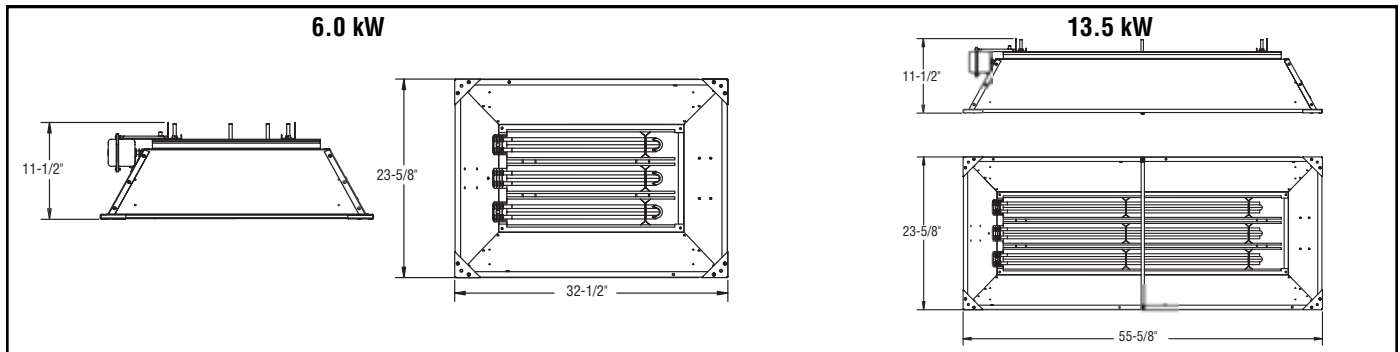

Figure 2

Specifications – Table 1

Model	Figure	Volts	KW	Amperage		BTU	Dimensions (In.)			Wire Ga. (Min.)	
				1 Phase	3 Phase		A Length	B Width	D Depth	1 Phase	3 Phase
STAR-02A-11-F	1	120	1.5	12.5	NA	5118	33-1/4	15-1/2	11-9/16	14	NA
STAR-02A-81-F		208	2	9.6	NA	6824				14	NA
STAR-02A-21-F		240	2	8.3	NA	6824				14	NA
STAR-02A-71-F		277	2	7.2	NA	6824				14	NA
STAR-02A-41-F		480	2	4.2	NA	6824				14	NA
STAR-02A-61-F*		600	2	3.3	NA	6824				14	NA
STAR-05A-81-F	1	208	4.5	21.6	NA	15354	55-3/4	15-1/2	11-9/16	12	NA
STAR-05A-21-F		240	4.5	18.8	NA	15354				12	NA
STAR-05A-71-F		277	4.5	15.9	NA	15354				14	NA
STAR-05A-41-F		480	4.5	9.4	NA	15354				14	NA
STAR-05A-61-F*		600	4.5	7.5	NA	15354				14	NA
STAR-06A-83-F	2	208	6	28.8	16.7	20472	32-1/2	23-5/8	11-1/2	10	12
STAR-06A-23-F		240	6	25.0	14.4	20472				10	12
STAR-06A-71-F		277	6	21.7	—	20472				10	—
STAR-06A-43-F		480	6	12.5	7.2	20472				12	12
STAR-06A-63-F*		600	6	10.0	5.8	20472				12	12
STAR-14A-83-F	2	208	13.5	NR	37.5	46062	55-5/8	23-5/8	11-3/4	NR	10
STAR-14A-23-F		240	13.5	NR	32.5	46062				NR	10
STAR-14A-71-F		277	13.2	47.7	—	45038				8	—
STAR-14A-43-F		480	13.5	28.1	16.2	46062				12	12
STAR-14A-63-F*		600	13.5	22.5	13.0	46062				12	12

\* Not UL or CSA

NA - Not Available

NR - Not Recommended

## GENERAL

**IMPORTANT:  
SAVE THESE INSTRUCTIONS**

### **⚠ WARNING**

**FIRE HAZARD. Do not use as a residential or household heater. Keep combustible material away from heater. Do not operate heater where flammable vapors, gases or liquids are present.**

**To avoid personal injury read "IMPORTANT INSTRUCTIONS" on this page before installation or operation of heater.**

## INSTALLATION

The Chromalox STAR radiant heater is shipped fully assembled. The heater can be hung from the ceiling with 4 chains or rigid angle brackets attached to the heater brackets located on the back of the heater, for 2 and 4.5 kW heaters, chains can be attached to the four holes in the corners of the back reflector. (Chromalox offers hanging chain kits for these heaters that will allow for installations 2 to 6 feet from the ceiling.) Minimum spacings:

Ceiling to top of heater is 2 feet.

Wall to sides of heater is 3 feet.

### **⚠ CAUTION**

Floor to bottom of heater is 10 feet.

**Installer should consult state and local codes and meet any applicable requirements regarding the installation.**

**When used as a portable heater, do not leave the heater unattended while in operation.**

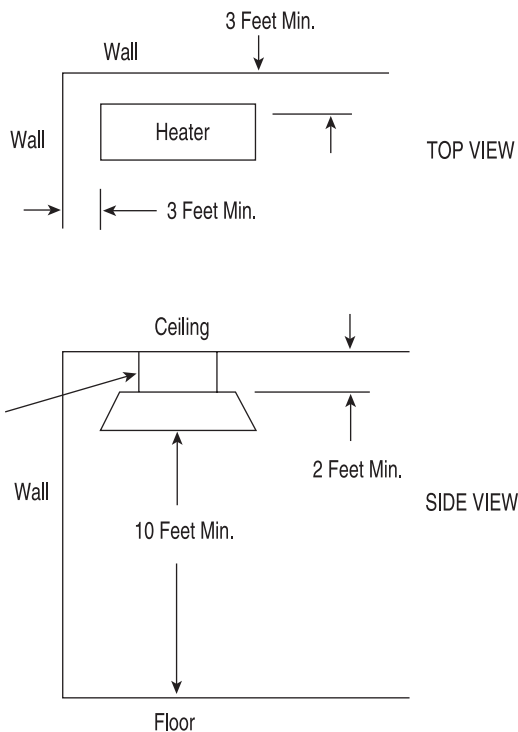

Figure 4

## IMPORTANT INSTRUCTIONS

When using electrical appliances, basic precautions should always be followed to reduce risk of fire, electric shock and injury to persons, including the following:

1. Read all instructions before using this heater.
2. This heater is hot when in use. To avoid burns, do not let bare skin touch hot surfaces. Keep combustible materials, such as furniture and papers at least 7 feet from the front of the heater.
3. Always disconnect heater when not in use.
4. Do not use outdoors in areas subject to wind.
5. Connect to properly grounded outlets or building ground.
6. This heater has hot surfaces. Do not use it in areas where gasoline, paint or flammable liquids are used or stored.
7. Use this heater only as described in this manual. Any other use not recommended by the manufacturer may cause fire, electric shock or injury to persons.
8. In order to prevent equipment damage, protect with a ground fault device such as Chromalox STAR-GF series monitor.
9. **SAVE THESE INSTRUCTIONS**

## WIRING

### ⚠ WARNING

**ELECTRIC SHOCK HAZARD. Disconnect all power before installing or servicing heater. Failure to do so could result in personal injury or property damage. Heater must be effectively grounded in accordance with the National Electrical Code, NFPA 70.**

### ⚠ WARNING

**All electrical wiring must be done by a qualified person in accordance with National Electrical Code (NEC) and meet all state and local regulations.**

1. Use heater only at the voltage specified on the nameplate.
2. Branch circuit wire for connection to heater must be at least 90°C wire. Use copper conductors only.

3. The heater connection points are located in the gasketed terminal enclosure. To remove cover, remove 4 screws on the cover. Remove the cover to expose wiring connection points.
4. A green ground terminal is provided in the bottom of the enclosure. The ground wire should be connected before other connections are made.
5. Refer to Table 1 for proper entrance wiring size.
6. Heater can be wired with rigid or flexible conduit.
7. All 3 element heaters are factory pre-wired for 3-phase delta operation. Some units can be converted to single phase operation by changing the wiring. Refer to Table 1 for those heaters that can be converted to single phase. The appropriate wiring diagram (Figure 3) is also located on the bottom of the enclosure.

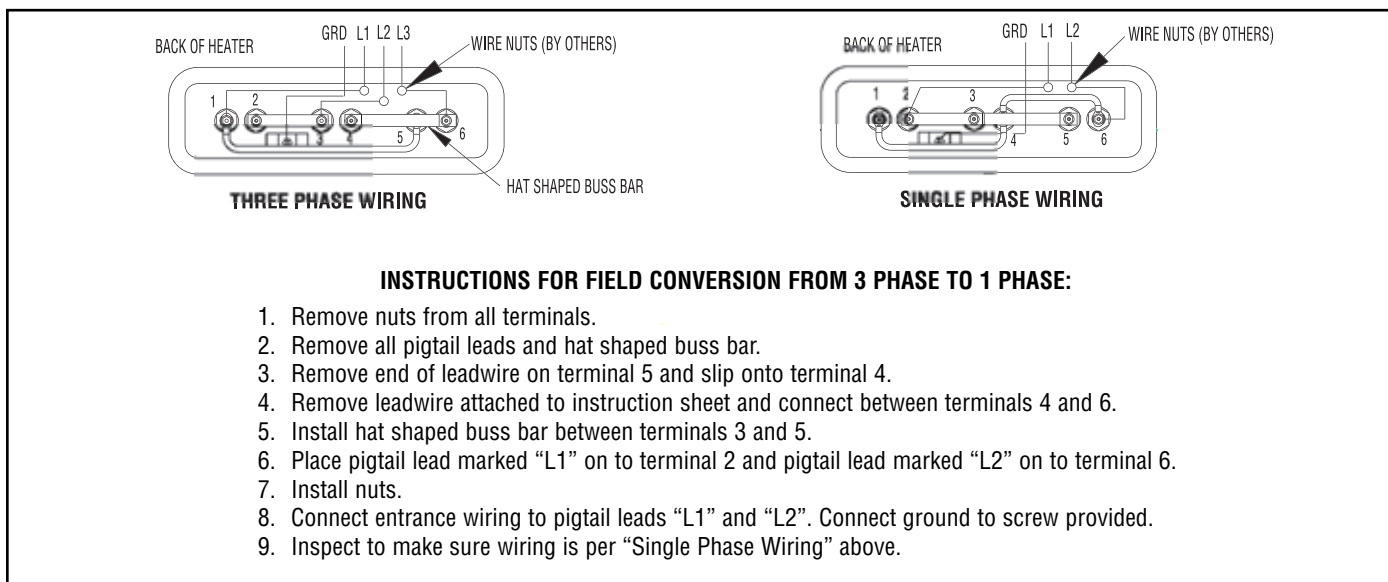

## OPTIONAL ACCESSORIES

Chromalox STAR series radiant heaters can be field modified by adding optional kits. Refer to Chart A to select the proper kit.

### Portable Cart Kit

The portable cart kit can be used to convert a fixed overhead unit into a portable heating device where a fixed installation is not required. This kit includes wheels, legs, handle, grill(s), baffle (if reqd) and all of the necessary hardware to complete the modification. See instruction bulletin PG435 for details.

### Grill Kit

The grill kit consists of one (1.5, 2, 4.5 and 6 kW) or 2 grill sections (13.5kW) and hardware to protect personnel from coming into contact with hot radiant heating elements. See instruction bulletin PG437 for details.

### Disconnect Kit

The disconnect kit consists of a complete assembly consisting of a disconnect switch (3 Pole), power terminal block and all hardware to complete the installation. This kit can be mounted to both the fixed, overhead heater or the portable heater; see instruction bulletin PG436 for details.

### Hanger Kit

Hanger kits include 24 feet of chain and four S hooks to mount the unit in a fixed overhead position using the universal mounting brackets included on the heater. This kit allows installation distances from the ceiling of 2 feet to 6 feet. See installation diagram Fig. 4 on page 2.

### Cord Kits (Portable Only)

Cord kits consist of 25 feet of 90°C cable and a right angle cord fitting which can connect directly to the heater terminal box or disconnect switch (if used). See installation bulletin PF491 for details.

### Tip Over and Ground Fault Kits

STAR TIP Series Kit attaches to portable heater and de-energizes the heater in the event it is tipped over.

STAR-GF Series Kit mounts to wall that de-energizes heater prior to element failure.

STAR-TG Kit combines the tip over and ground fault feature for portable heaters. See installation bulletin PG436.

## OPTIONAL ACCESSORIES

**Chart A – Kit Selection Guide**

Model	Grill Kit	Disconnect Kit	Hanger Kit	Wall Mount Ground Fault	Portable Cart Kit**
STAR-02A-11-F	PCN 111878	PCN 340662	PCN 340654	NA	NA
STAR-02A-81-F	PCN 111878			PCN 340777	NA
STAR-02A-21-F	PCN 111878			PCN 340785	NA
STAR-02A-71-F	PCN 111878			PCN 340793	NA
STAR-02A-41-F	PCN 111878			PCN 340806	NA
STAR-02A-61-F	PCN 111878			PCN 340814	NA
STAR-05A-81-F	PCN 111894			PCN 340777	PCN 340620
STAR-05A-21-F	PCN 111894			PCN 340785	PCN 340620
STAR-05A-71-F	PCN 111894			PCN 340793	PCN 340620
STAR-05A-41-F	PCN 111894			PCN 340806	PCN 340620
STAR-05A-61-F	PCN 111894			PCN 340814	PCN 340620
STAR-06A-83-F	PCN 340638			PCN 340777	PCN 340830
STAR-06A-23-F	PCN 340638			PCN 340785	PCN 340830
STAR-06A-71-F	PCN 340638			PCN 340793	PCN 340830
STAR-06A-43-F	PCN 340638			PCN 340806	PCN 340830
STAR-06A-63-F	PCN 340638			PCN 340814	PCN 340830
STAR-14A-83-F	PCN 340857			PCN 340777	PCN 340849
STAR-14A-23-F	PCN 340857			PCN 340785	PCN 340849
STAR-14A-71-F	PCN 340857			PCN 340793	PCN 340849
STAR-14A-43-F	PCN 340857			PCN 340806	PCN 340849
STAR-14A-63-F	PCN 340857	PCN 340814	PCN 340849		

\*\* Includes Grill(s)

## MAINTENANCE

### **⚠ WARNING**

***ELECTRIC SHOCK HAZARD. Disconnect all power before servicing or replacing heating elements.***

The reflectors should be kept clean to obtain the maximum radiant output.

#### **Element Replacement**

1. Remove Terminal Box Cover.
2. Disconnect lead wires from heater terminals and disengage box from conduit /cable fitting.
3. Remove safety grills (if installed).
4. Remove retainer screw located on the reflector at the terminal end.
5. Loosen (2), 3/8" nuts from the terminal box bracket located on the back of the heater and slide the entire heating element assembly out of the reflector assembly.

6. Remove wires and jumper straps as required to replace the failed heating element(s).
7. Remove bulkhead fitting nuts and washers.
8. Remove failed element and replace with a new element. Replace only with genuine Chromalox "Arctic End" elements. Use of other elements will cause excess temperatures inside terminal box.
9. Place gasket on the bulkhead fitting and insert terminals and fittings into the element holes in the terminal box.
10. Place washers and nuts on bulkhead fittings and tighten.
11. Replace wiring and jumper straps ( see Fig. 1).
12. Reassemble by following the reverse procedures (steps 5 through 1).

## RENEWAL PARTS IDENTIFICATION

Model	Element***	Element Housing Reflector	Safety Screen	Terminal Box Gasket
STAR-02A-11-F	PCN 106059	234-891755-004	PCN 111878	132-304879-004
STAR-02A-81-F	PCN 106067		PCN 111878	132-304879-004
STAR-02A-21-F	PCN 106075		PCN 111878	132-304879-004
STAR-02A-71-F	PCN 106083		PCN 111878	132-304879-004
STAR-02A-41-F	PCN 106091		PCN 111878	132-304879-004
STAR-02A-61-F	PCN 106104		PCN 111878	132-304879-004
STAR-05A-81-F	PCN 106403	234-891755-002	PCN 111894	132-304879-004
STAR-05A-21-F	PCN 106411		PCN 111894	132-304879-004
STAR-05A-71-F	PCN 106796		PCN 111894	132-304879-004
STAR-05A-41-F	PCN 106964		PCN 111894	132-304879-004
STAR-05A-61-F	PCN 106972		PCN 111894	132-304879-004
STAR-06A-83-F	PCN 106067	234-891755-004	PCN 340638	132-304879-003
STAR-06A-23-F	PCN 106075		PCN 340638	132-304879-003
STAR-06A-71-F	PCN 106083		PCN 340638	132-304879-003
STAR-06A-43-F	PCN 106091		PCN 340638	132-304879-003
STAR-06A-63-F	PCN 106104		PCN 340638	132-304879-003
STAR-14A-83-F	PCN 106403	234-891755-002	PCN 340857	132-304879-003
STAR-14A-23-F	PCN 106411		PCN 340857	132-304879-003
STAR-14A-71F	PCN 106796		PCN 340857	132-304879-003
STAR-14A-43-P	PCN 106964		PCN 340857	132-304879-003
STAR-14A-63-P	PCN 106972		PCN 340857	132-304879-003

\*\*\* Includes element supports

**Parts Common to All Models:**

Bulkhead fitting gasket . . . . . 132-895735-008  
 Bulkhead fitting washer . . . . . 328-890675-014  
 Bulkhead fitting nut . . . . . 200-890615-031  
 Element Support . . . . . 291-304869-002

#### **WARRANTY AND LIMITATION OF REMEDY AND LIABILITY**

Chromalox warrants only that the Products and parts manufactured by Chromalox, when shipped, and the work performed by Chromalox when performed, will meet all applicable specification and other specific product and work requirements (including those of performance), if any, and will be free from defects in material and workmanship under normal conditions of use. All claims for defective or nonconforming (both hereinafter called defective) Products, parts or work under this warranty must be made in writing immediately upon discovery, and in any event, within one (1) year from delivery, provided, however all claims for defective Products and parts must be made in writing no later than eighteen (18) months after shipment by Chromalox. Defective and nonconforming items must be held for Chromalox's inspections and returned to the original f.o.b. point upon request. THE FOREGOING IS EXPRESSLY IN LIEU OF ALL OTHER WARRANTIES WHATSOEVER, EXPRESS, IMPLIED AND STATUTORY, INCLUDING, WITHOUT LIMITATION, THE IMPLIED WARRANTIES OF MERCHANTABILITY AND FITNESS FOR A PARTICULAR PURPOSE.

Notwithstanding the provisions of this WARRANTY AND LIMITATION Clause, it is specifically understood that Products and parts not manufactured and work not performed by Chromalox are warranted only to the extent and in the manner that the same are warranted to Chromalox by Chromalox's vendors, and then only to the extent that Chromalox is reasonably able to enforce such warranty, it being understood Chromalox shall have no obligation to initiate litigation unless Buyer undertakes to pay all cost and expenses therefor, including but not limited to attorney's fees, and indemnifies Chromalox against any liability to Chromalox's

vendors arising out of such litigation.

Upon Buyer's submission of a claim as provided above and its substantiation, Chromalox shall at its option either (i) repair or replace its Products, parts or work at the original f.o.b. point of delivery or (ii) refund an equitable portion of the purchase price.

THE FOREGOING IS CHROMALOX'S ONLY OBLIGATION AND BUYER'S EXCLUSIVE REMEDY FOR BREACH OF WARRANTY, AND IS BUYER'S EXCLUSIVE REMEDY AGAINST CHROMALOX FOR ALL CLAIMS ARISING HEREUNDER OR RELATING HERETO WHETHER SUCH CLAIMS ARE BASED ON BREACH OF CONTRACT, TORT (INCLUDING NEGLIGENCE AND STRICT LIABILITY) OR OTHER THEORIES, BUYER'S FAILURE TO SUBMIT A CLAIM AS PROVIDED ABOVE SHALL SPECIFICALLY WAIVE ALL CLAIMS FOR DAMAGES OR OTHER RELIEF, INCLUDING BUT NOT LIMITED TO CLAIMS BASED ON LATENT DEFECTS. IN NO EVENT SHALL BUYER BE ENTITLED TO INCIDENTAL OR CONSEQUENTIAL DAMAGES AND BUYER SHALL HOLD CHROMALOX HARMLESS THEREFROM. ANY ACTION BY BUYER ARISING HEREUNDER OR RELATING HERETO, WHETHER BASED ON BREACH OF CONTRACT, TORT (INCLUDING NEGLIGENCE AND STRICT LIABILITY) OR OTHER THEORIES, MUST BE COMMENCED WITHIN ONE (1) YEAR AFTER THE DATE OF SHIPMENT OR IT SHALL BE BARRED.

**W2008M**

# **Chromalox<sup>®</sup>**

## **PRECISION HEAT AND CONTROL**

2150 N. RULON WHITE BLVD., OGDEN, UT 84404  
Phone: 1-800-368-2493      www.chromalox.com