

Chromalox®

Installation, Operation and RENEWAL PARTS IDENTIFICATION

SERVICE REFERENCE

DIVISION 4	SECTION EH-HVT
SALES REFERENCE (Supersedes PF421-5)	PF421-6
	161-048557-001
DATE	APRIL, 2003

Type EH and HVT Electric Utility Heater



Type EH



Type HVT*

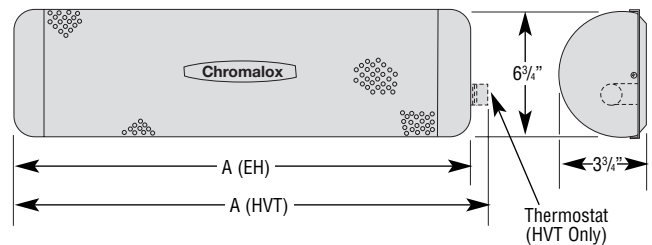

Specifications – Table A

Model	VoltS	WattS	Dim. "A" (In.)	BTUH
EH-1221	120	250	14 ⁵ / ₈	853
EH-1221	240	250	14 ⁵ / ₈	853
EH-1251	120	500	14 ⁵ / ₈	1706
EH-1251	240	500	14 ⁵ / ₈	1706
HVT-1251*	120	500	28 ⁵ / ₈	1706
HVT-2411*	120	1000	28 ⁵ / ₈	3412

*HVT models are equipped with a 55°F to 110°F adjustable thermostat.

NOTICE: Carefully remove heater from carton and check for shipping damage. Any damage claims should be entered immediately with the carrier.

GENERAL

⚠ WARNING

FIRE HAZARD. Since heaters are capable of developing high temperatures, extreme care should be taken to:

- Locate on vertical wall with length of heater positioned horizontally. HVT models must be installed with thermostat at right end;
- Avoid mounting into a wall recess since such mounting interferes with free air circulation, increases heater temperatures, and prevents proper thermostat operation on HVT models;
- Mount heaters with a minimum clearance of 24" above floor level or from adjacent wall;

D. Keep all combustible materials a minimum of 4" from front and top of heater.

- Remove screw from each end and remove perforated cover.
- After feeding electrical wiring through opening in back of heater (See WIRING section), mount back of heater to wall with four screws (HVT models-5/16" diameter holes on 5" x 25-7/8") (EH models 9/32" diameter holes on 5x12-1/2" centers) through back of heater. Leave one pair of end screws snug, but not tight, to avoid expansion noise due to binding.

WIRING

⚠ WARNING

ELECTRIC SHOCK HAZARD. Disconnect all power before installing or servicing heater. Failure to do so could result in personal injury or property damage. Heater must be installed by a qualified person in accordance with the National Electrical Code, NFPA 70.

⚠ WARNING

ELECTRIC SHOCK HAZARD. Any installation involving electric heaters must be performed by a qualified person and must be effectively grounded in accordance with the National Electrical Code to eliminate shock hazard.

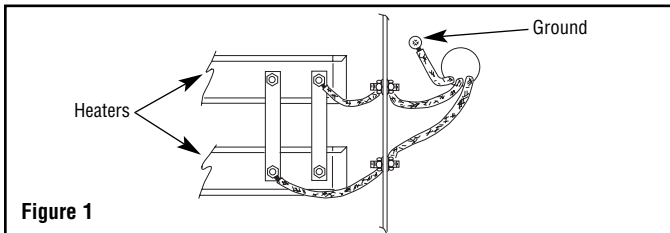

Note: Electrical wiring is to be in accordance with National Electrical Code.

1. Electrical wiring enters heater case through 7/8" opening in back of heater.
2. Grounding conductor, with green insulation, should be secured under green colored ground screw located in wiring compartment. (See Figures 1 and 2).
3. HVT Model only — The white insulated lead of the incoming power line should be attached to the L1 terminal of the terminal block. (See Figure 2)
4. Replace cover and end screws (removed in step 4, **MOUNTING** section).

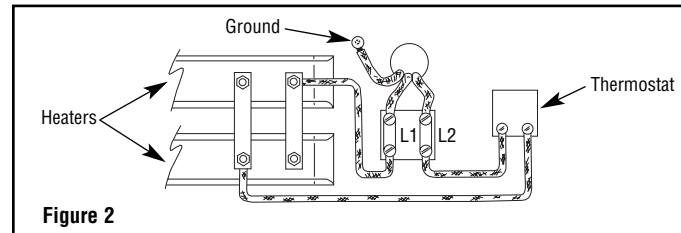

OPERATION

⚠ WARNING

FIRE HAZARD. Keep combustible materials and such fabrics at least 4" away from front of cover or above cover. Failure to comply could result in personal injury or property damage.

⚠ WARNING

FIRE/EXPLOSION HAZARD. This heater is not intended for use in hazardous atmospheres where flammable vapors, gases, liquids or other combustible atmospheres are present as defined in the National Electrical Code. Failure to comply can result in personal injury or property damage.

MAINTENANCE

⚠ WARNING

ELECTRIC SHOCK HAZARD. Disconnect all power before installing or servicing heater. Failure to do so could result in personal injury or property damage. Heater must be installed by a qualified person in accordance with the National Electrical Code, NFPA 70.

1. Following long periods of idleness, heater should be vacuumed before start-up to remove accumulated combustible particles which will incinerate causing smoking and consequent wall discoloration.
2. If heater is located in areas of heavy traffic, furnish suitable heater guard (wall mounted pipe rail in front of case, for example) to prevent damage to heater.

RENEWAL PARTS IDENTIFICATION

Model	Watts	Front Cover	Heating Elements		Terminal Block	Thermostat Kit (See Below)
			120V	240V		
EH-1221	250	080-016362-002	285-051049-001	285-051049-002	_____	_____
EH-1251	500	080-016362-002	285-051049-001 (2)	285-051049-002 (2)	_____	_____
HVT-1251	500	080-016362-003	285-051049-006	_____	303-047610-005	168-073659-001
HVT-2411	1000	080-016362-003	285-051049-006 (2)	_____	303-047610-005	168-073659-001

Note: Part numbers suffixed by a number in () indicates the quantity of same part number used.

THERMOSTAT REPLACEMENT PROCEDURE

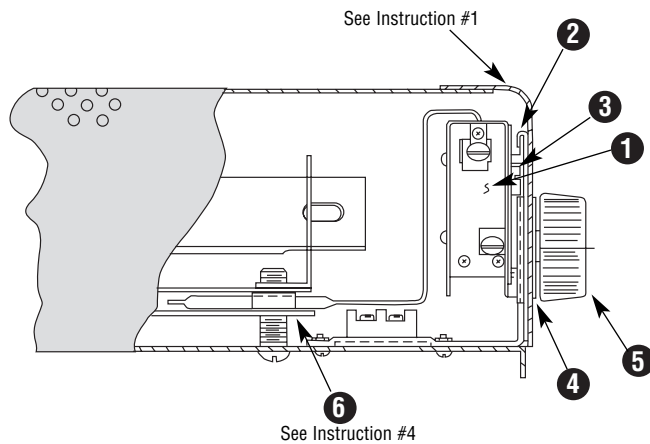

Thermostat Kit (168-073659-001)			
Item No.	Qty.	Part No.	Description
①	1	300-072275-007	Thermostat
②	1	027-073304-002	Bracket — Mounting
③	2	248-048179-020	Screws
④	1	220-072276-003	Plate-Dial Thermostat
⑤	1	169-073294-001	Knob
⑥	1	056-073305-001	Clamp — Capillary Bulb

Thermostat Replacement Instructions:

1. Remove cover.
2. Slide thermostat mounting bracket over existing plate.
3. Using item ③ (screws) assemble item ① (thermostat) to item ② (bracket).
4. Remove bolt and assemble item ⑥ capillary clamp and capillary bulb and re-install bolt. Note: Do not pinch bulb in clamp, thermostat decalibration will result.
5. Assemble item ④ (plate) and item ⑤ (knob).
6. Re-install cover.

WARRANTY AND LIMITATION OF REMEDY AND LIABILITY

Chromalox warrants only that the Products and parts manufactured by Chromalox, when shipped, and the work performed by Chromalox when performed, will meet all applicable specification and other specific product and work requirements (including those of performance), if any, and will be free from defects in material and workmanship under normal conditions of use. All claims for defective or nonconforming (both hereinafter called defective) Products, parts or work under this warranty must be made in writing immediately upon discovery, and in any event, within one (1) year from delivery, provided, however all claims for defective Products and parts must be made in writing no later than eighteen (18) months after shipment by Chromalox. Defective and nonconforming items must be held for Chromalox's inspections and returned to the original f.o.b. point upon request. THE FOREGOING IS EXPRESSLY IN LIEU OF ALL OTHER WARRANTIES WHATSOEVER, EXPRESS, IMPLIED AND STATUTORY, INCLUDING, WITHOUT LIMITATION, THE IMPLIED WARRANTIES OF MERCHANTABILITY AND FITNESS FOR A PARTICULAR PURPOSE.

Notwithstanding the provisions of this WARRANTY AND LIMITATION Clause, it is specifically understood that Products and parts not manufactured and work not performed by Chromalox are warranted only to the extent and in the manner that the same are warranted to Chromalox by Chromalox's vendors, and then only to the extent that Chromalox is reasonably able to enforce such warranty, it being understood Chromalox shall have no obligation to initiate litigation unless Buyer undertakes to pay all cost and expenses therefor, including but not limited to attorney's fees, and indemnifies Chromalox against any liability to Chromalox's

vendors arising out of such litigation.

Upon Buyer's submission of a claim as provided above and its substantiation, Chromalox shall at its option either (i) repair or replace its Products, parts or work at the original f.o.b. point of delivery or (ii) refund an equitable portion of the purchase price.

THE FOREGOING IS CHROMALOX'S ONLY OBLIGATION AND BUYER'S EXCLUSIVE REMEDY FOR BREACH OF WARRANTY, AND IS BUYER'S EXCLUSIVE REMEDY AGAINST CHROMALOX FOR ALL CLAIMS ARISING HEREUNDER OR RELATING HERETO WHETHER SUCH CLAIMS ARE BASED ON BREACH OF CONTRACT, TORT (INCLUDING NEGLIGENCE AND STRICT LIABILITY) OR OTHER THEORIES, BUYER'S FAILURE TO SUBMIT A CLAIM AS PROVIDED ABOVE SHALL SPECIFICALLY WAIVE ALL CLAIMS FOR DAMAGES OR OTHER RELIEF, INCLUDING BUT NOT LIMITED TO CLAIMS BASED ON LATENT DEFECTS. IN NO EVENT SHALL BUYER BE ENTITLED TO INCIDENTAL OR CONSEQUENTIAL DAMAGES AND BUYER SHALL HOLD CHROMALOX HARMLESS THEREFROM. ANY ACTION BY BUYER ARISING HEREUNDER OR RELATING HERETO, WHETHER BASED ON BREACH OF CONTRACT, TORT (INCLUDING NEGLIGENCE AND STRICT LIABILITY) OR OTHER THEORIES, MUST BE COMMENCED WITHIN ONE (1) YEAR AFTER THE DATE OF SHIPMENT OR IT SHALL BE BARRED.

W2008M

Chromalox®
PRECISION HEAT AND CONTROL

2150 N. RULON WHITE BLVD., OGDEN, UT 84404
Phone: 1-800-368-2493 www.chromalox.com