

PRODUCT INFORMATION PACKET

Model No: UST1072

Catalog No: UST1072

3/4 HP Pool Pump Motor, 1 phase, 3600 RPM, 230/115 V, 56J Frame, ODP



Regal and are trademarks of Regal Rexnord Corporation or one of its affiliated companies.
©2022 Regal Rexnord Corporation, All Rights Reserved. MC017097E

Nameplate Specifications

Output HP	3/4 Hp	Output KW	0.56 kW
Frequency	60 Hz	Voltage	230/115 V
Current	5.5/11.0 A	Speed	3450 rpm
Service Factor	1	Phase	1
Duty	Continuous	Insulation Class	B
Frame	56J	Enclosure	Open Drip Proof
Thermal Protection	Automatic	Ambient Temperature	50 °C
UL	Recognized	CSA	Y
Number of Speeds	1		

Technical Specifications

Electrical Type	Cap Start Motor	Poles	2
Rotation	Counterclockwise Pump End	Mounting	C Face
Motor Orientation	Horizontal	Drive End Bearing	Ball
Opp Drive End Bearing	Ball	Frame Material	Rolled Steel
Shaft Type	7/16 THREADS	Overall Length	13.20 in
Frame Length	7.38 in	Shaft Diameter	0.625 in
Shaft Extension	2.56 in		
Connection Drawing	627103-006	Outline Drawing	UST1072-S01

This is an uncontrolled document once printed or downloaded and is subject to change without notice. Date Created:05/10/2022

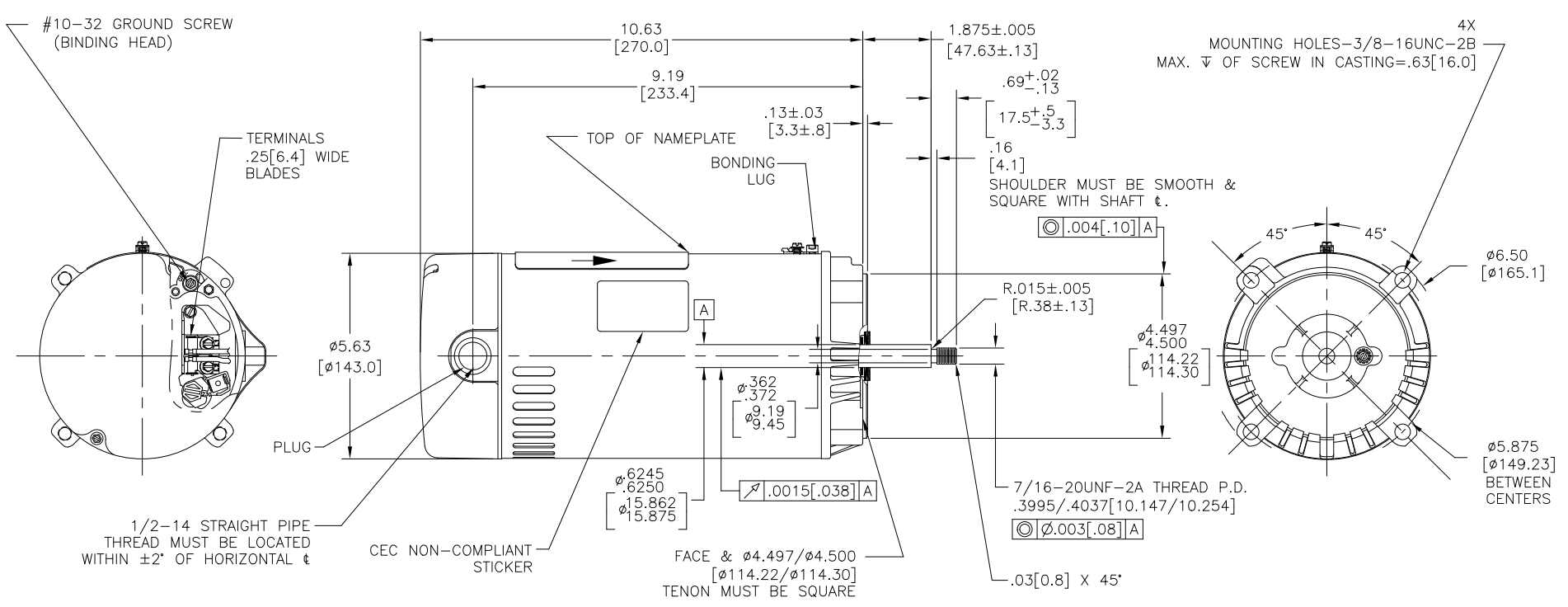

NAMEPLATE DATA	EXTERNAL CONNECTION DIAGRAM	NOTES
MODEL: C48J2N131C1C CUST PN: UST1072 HP: 3/4 SF: 1.0 ROT: CCWPE RPM: 3450 TYPE: UAC CODE: H FORM: FRAME: 56J VOLTS: 230/115 AMPS: MAX AMPS: 5.3/10.6 SF AMPS: - PH: 1 HZ: 60 INS: B AMB: 50 DUTY: CONT ENCLOSURE: ODP THERM. PROT.	<p>GROUND (INDICATED)</p> <p>HIGH VOLT CONNECTION AS SHOWN, TO CHANGE TO LOW VOLT, MOVE THE BLACK PLUG TO ALIGN THE ARROWS AT THE 115V LOCATION. USE COPPER CONDUCTORS ONLY. INSTALL MOTOR WITH VENTS DOWN. ACCEPTABLE FOR FIELD WIRING</p>	<ol style="list-style-type: none"> 1. FINISH PAINT TO BE SATIN BLACK. 2. .44[11.1] WRENCH FLATS ON SHAFT-FOR ACCESS TO THIS WRENCH FLAT REMOVE END COVER. 3. STAINLESS STEEL SHAFT EXT. 4. LIMITS ON AMPLITUDE OF VIBRATION MEASURED AT BEARING HOUSING = .001[.03]. 5. DUAL VOLTAGE MOTORS ARE TO BE CONNECTED FOR HIGHER VOLTAGE. QUICK VOLTAGE CHANGE PLUG INCLUDED ON THE TERMINAL BOARD. 6. CTQ REQUIREMENT SEE EP000105-008. 7. RoHS & REACH REQUIREMENT SEE EP000014.

PERFORMANCE CURVE	APPROVED SAMPLE		
C48J2W34			
UL COMPONENT	CSA		
FILE#	CCN#	FILE#	GUIDE#
E25022	XEWR2	LR43341	4211-01
CUSTOMER	DISTRIBUTION SERVICES		

CRITICAL TO QUALITY CHARACTERISTICS(CTQs) P PROCESS E ENGINEERING A APPLICATION R REGULATORY L LIFE	DRAWING REVISION ECO ECR-0216845 ECO DESCRIPTION SEE ECR	REVISION BY HAIKUA ZHANG APPROVED BY TRISTIA ZHAO	DATE 04-19-2022 DATE 04-19-2022	TOLERANCES UNLESS OTHERWISE SPECIFIED DEC. INCH mm ANGLE .X ±.02 [±.5] .XX ±0.005 [±0.13] .XXX ±0.0005 [±0.013] REMOVE BURRS & BREAK SHARP EDGES .003,015 [Ø.08,Ø.38] CORNER FILLETS .02 [5] MACHINED SURFACES 12/ mm 3/2 mm SHOWN IN [BRACKETS]	DRAWN BY: Richard Pan DATE: APPROVED BY: DATE: REFERENCE:	REGAL™ Regal Beloit America, Inc. DESCRIPTION MODEL-PFHP-48FR OUTLINE MATERIAL: - PROCESS/FINISH: - SIZE DWG NO: - UST1072 SHEET 1
	COPYRIGHT REGAL BELOIT AMERICA, INC. ALL RIGHTS RESERVED. PROPRIETARY AND CONFIDENTIAL INFORMATION - THIS DOCUMENT IS THE PROPERTY OF REGAL BELOIT AMERICA, INC. (OWNER) AND COMPANY'S PROPRIETARY INFORMATION. ANY PERSON, CORPORATION OR OTHER FIRM RECEIVING IT IS DENIED, BY RECEIVING IT, TO AGREE THAT IT, AND/OR ANY PART OF IT, SHALL NOT BE DISCLOSED TO ANY PERSON, CORPORATION, OR OTHER FIRM, WITHOUT THE EXPRESS WRITTEN PERMISSION OF REGAL BELOIT AMERICA, INC. IF YOU ARE NOT AN EMPLOYEE OF REGAL BELOIT AMERICA, INC. THIS DOCUMENT SHALL BE RETURNED TO OWNER UPON REQUEST. IT MAY BE SUBJECT TO CERTAIN RESTRICTIONS UNDER APPLICABLE EXPORT CONTROL LAWS AND REGULATIONS.				THIRD ANGLE PROJECTION	

REV	ECO	REV BY	DATE	APPD	DATE
B	0001487	D.MUÑOZ	04-13-2009	M.ARGUELLES	04-13-2009

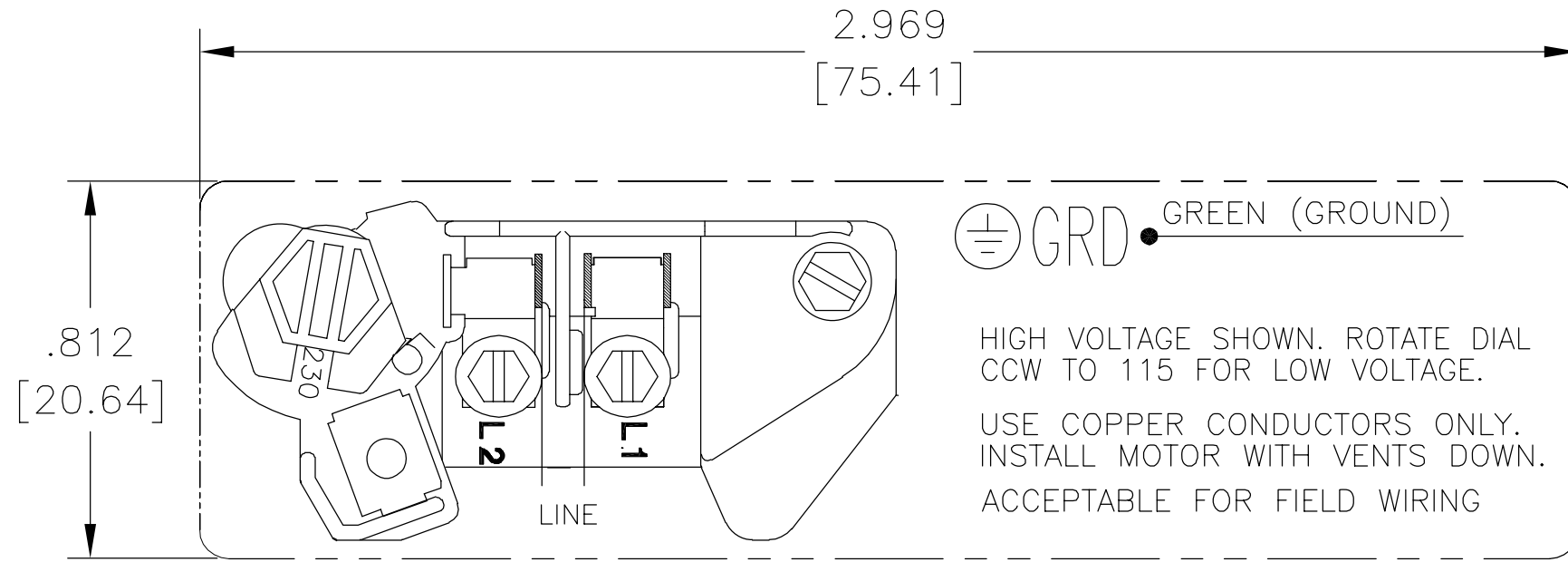

DUAL VOLTAGE

NOTE:

1. FOR USE WITH 616231 NAME PLATE BLANK.
2. — — — — INDICATES DIMENSIONAL LIMITS.
3. DIE MUST PRODUCE A LEGIBLE IMPRESSION.

GEOMETRIC CHARACTERISTICS & SYMBOLS

- ▭ FLATNESS
- STRAIGHTNESS
- ∠ ANGULARITY
- ⊥ PERPENDICULARITY (SQUARENESS)
- // PARALLELISM
- ROUNDNESS (CIRCULARITY)
- ⊘ CYLINDRICITY
- △ PROFILE OF ANY SURFACE
- ⌒ PROFILE OF ANY LINE
- ↑ RUNOUT
- ⊕ TRUE POSITION
- ◎ CONCENTRICITY
- ⊖ SYMMETRY

UNLESS OTHERWISE SPECIFIED
DIM. TOLERANCES ARE AS FOLLOWS:

INCH	±.1	±.02	±.005	±.0005
mm	±0.5	±0.13	±0.013	

ANG. ±.50 DEG

REMOVE BURRS & BREAK SHARP EDGES:

INCH	.003-.015	mm	0.1-0.4
------	-----------	----	---------

CORNER FILLETS TO:

INCH	.020	mm	0.5
------	------	----	-----

MACHINE SURFACES:

INCH	125	mm	3.2
------	-----	----	-----

METRIC DIMS. SHOWN IN [BRACKETS]

DR BY:	Daniel Muñoz	04-13-2009
APPD:		
THIRD ANGLE PROJECTION		EDS DATE 02-22-2009 FORMAT REV F
CONFIDENTIAL: THIS DRAWING AND ITS INFORMATION ARE THE EXCLUSIVE AND CONFIDENTIAL PROPERTY OF A.O. SMITH CORP. AND ARE NOT TO BE DISCLOSED, DUPLICATED, DISTRIBUTED OR OTHERWISE USED WITHOUT THE WRITTEN CONSENT OF A.O. SMITH CORP. -ALL RIGHTS RESERVED. ASME Y14.5M 1994		

 innovation has a name.		ELECTRICAL PRODUCTS COMPANY <small>A DIVISION OF A. O. SMITH CORPORATION</small>	
DESCRIPTION CONNECTION DIAGRAM EXTERNAL			
SIZE A	DWG NO 627103-006		
SCALE NONE			SHEET 1

REVISION:	ECO	REVISADO POR:	FECHA:	APROBADO POR:	FECHA:
B	0001487	D.MUÑOZ	04-13-2009	M.ARGUELLES	04-13-2009

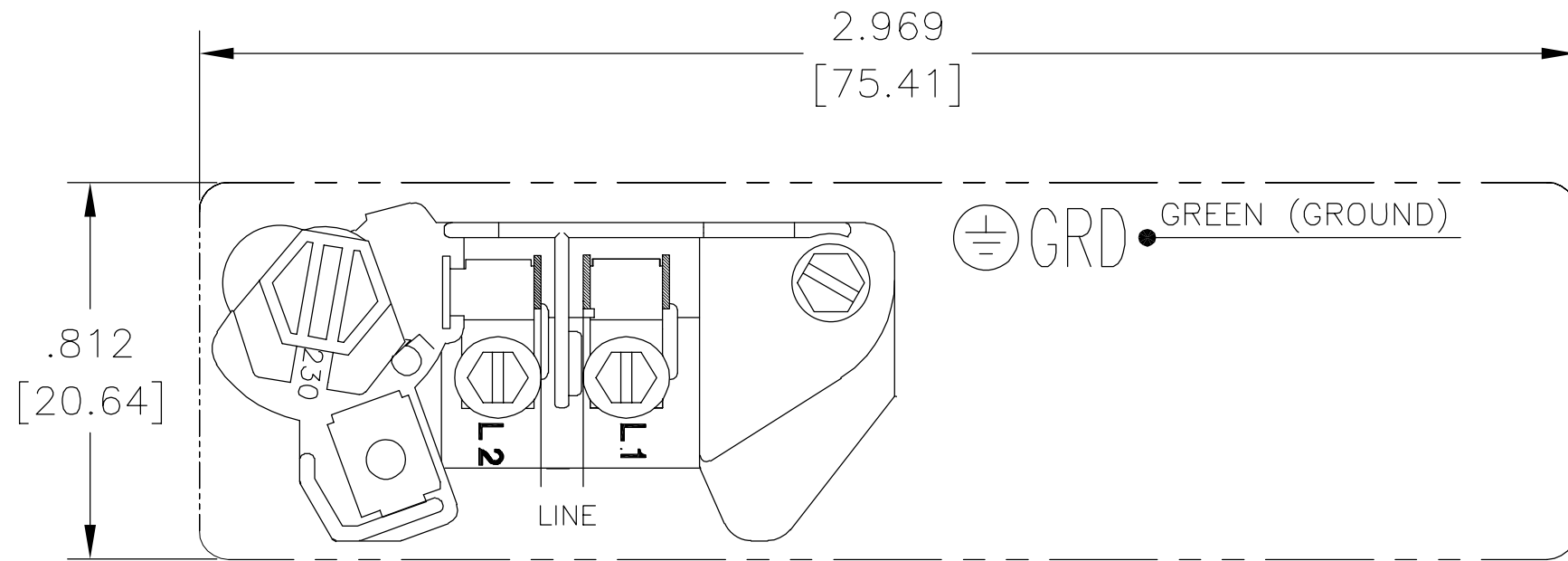

VOLTAJE DOBLE

NOTAS:

1. PARA USARSE CON LA PLACA DE DATOS EN BLANCO 616231.
2. — — — — INDICA LIMITES DIMENSIONALES.
3. EL DADO DEBE PRODUCIR UNA IMPRESION LEGIBLE.

CARACTERISTICAS DE GEOMETRIA Y SIMBOLOS

- ▭ PLANICIDAD
- RECTITUD
- ∠ ANGULARIDAD
- ⊥ PERPENDICULARIDAD (A ESCUADRA)
- // PARALELISMO
- REDONDEZ (CIRCULARIDAD)
- ⊘ CILINDRICIDAD
- △ PERFIL DE CUALQUIER SUPERFICIE
- ∩ PERFIL DE CUALQUIER LINEA
- ↑ VARIACION
- ⊕ POSICION REAL
- ◎ CONCENRICIDAD
- ≡ SIMETRIA

A MENOS QUE SE ESPECIFIQUE DE OTRA MANERA, LAS TOLERANCIAS DE LAS DIMS; SON LAS SIGUIENTES:

	X	XX	XXX	XXXX
PULG	±.1	±.02	±.005	±.0005
mm	±0.5	±0.13	±0.013	

ANG. ±.50 GRADOS
ELIMINAR REBABAS Y ORILLAS FILOSAS DEL BORDE.

PULG .003-.015 mm 0.1-0.4
FILETEAR ESQUINA: PULG .020 mm 0.5
MAQUINAR SUPERFICIES
PULG 125 mm 3.2

DIMS METRICAS MOSTRADAS [PARENTESIS]

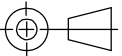
DIBUJADO POR: Daniel Muñoz	04-13-2009
APROBADO POR:	
TERCER ANGULO DE PROYECCION	
FECHA EDS: 02-22-2009	REV. FORMATO: F
CONFIDENCIAL: ESTE DIBUJO Y SU INFORMACION SON PROPIEDAD DE USO EXCLUSIVO Y CONFIDENCIAL DE A.O.SMITH CORP. Y NO DEBERAN SER REVELADOS, DUPLICADOS, DISTRIBUIDOS O USARSE DE OTRA MANERA SIN EL CONSENTIMIENTO ESCRITO DE A.O. SMITH CORP. -TODOS LOS DERECHOS RESERVADOS.ASME Y14.5M 1994	

 ELECTRICAL PRODUCTS COMPANY <small>A DIVISION OF A. O. SMITH CORPORATION</small>	
DESCRIPCION: CONNECTION DIAGRAM EXTERNAL	
TAMAÑO: A	NUMERO DE DIBUJO: 627103-006
ESCALA:NONE	HOJA: 1

版本	ECO	编制	日期	批准	日期
B	0001487	D.MUÑOZ	04-13-2009	M.ARGUELLES	04-13-2009

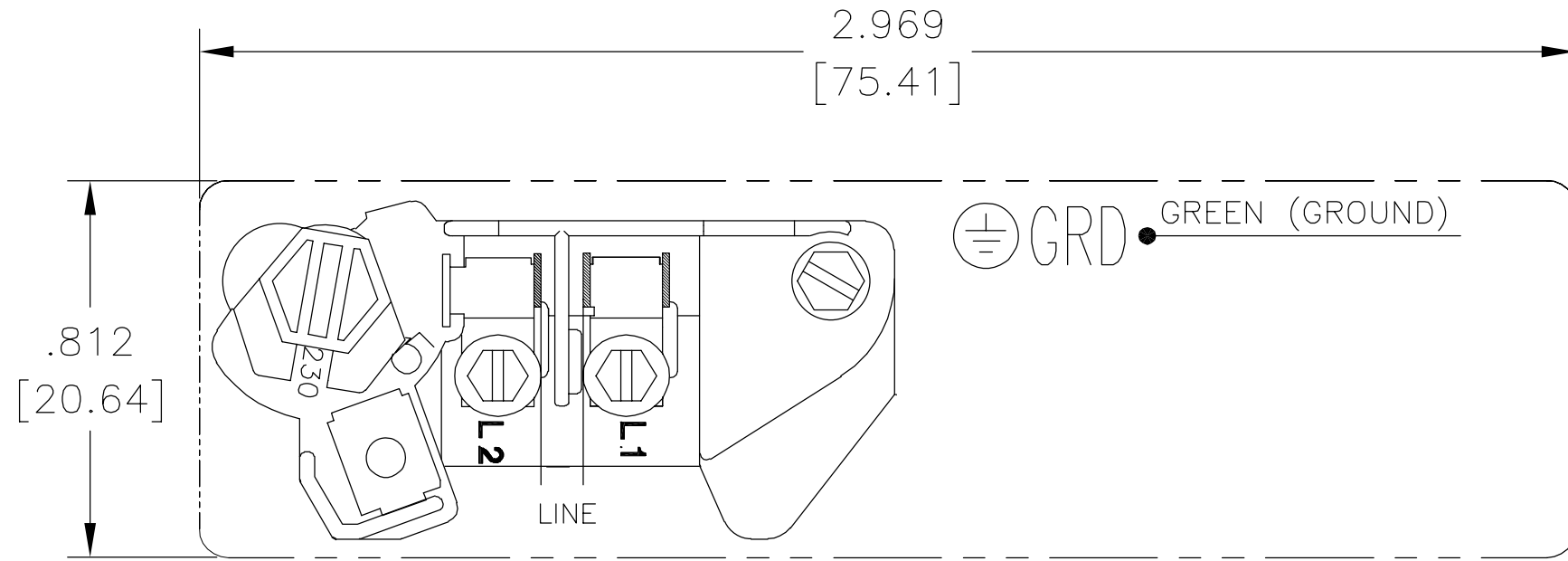

- 形位公差
- 平面度
- 直线度
- ∠ 倾斜度
- ⊥ 垂直度
- // 平行度
- 圆度
- ⊘ 圆柱度
- △ 面轮廓度
- ⌒ 线轮廓度
- ↗ 圆跳动
- ⊕ 位置度
- ◎ 同轴度
- ≡ 对称度

除另有注明
尺寸公差如下:

	X	XX	XXX	XXXX
英寸	±.1	±.02	±.005	±.0005
毫米	±0.5	±0.13	±0.013	
角度	±.50 度			
清理毛刺和尖棱				
英寸	.003-.015	毫米	0.1-0.4	
内圆角				
英寸	.020	毫米	0.5	
表面粗糙度				
英制	125	米制	3.2	

米制尺寸显示在 []

绘图:	Daniel Muñoz	04-13-2009
批准:		
第三角投影		图纸格式发布日期 02-22-2009 图纸格式版本 F
机密: 本图纸及相关信息所有权归A. O. SMITH公司所有。未经A. O. SMITH公司书面授权, 不得泄露、复制、传播或作其他用途。—版权所有		
ASME Y14.5M 1994		

		ELECTRICAL PRODUCTS COMPANY <small>A DIVISION OF A. O. SMITH CORPORATION</small>	
名称		CONNECTION DIAGRAM EXTERNAL	
图幅	A	图号	627103-006
比例	NONE	页号	1