

PRODUCT INFORMATION PACKET



Model No: UH1036NB
Catalog No: UH1036NB
Unit Heater Motor, 1/3 HP, 1 Ph, 60 Hz, 115 V, 1100 RPM, 2 Speed, 48 Frame, TEAO



Regal and Century are trademarks of Regal Rexnord Corporation or one of its affiliated companies.
©2022 Regal Rexnord Corporation, All Rights Reserved. MC017097E





Nameplate Specifications

Output HP	1/3 Hp	Output KW	0.25 kW
Frequency	60 Hz	Voltage	115 V
Current	4.3-1.8 A	Speed	1100 rpm
Service Factor	1	Phase	1
Duty	Air Over	Insulation Class	B
Frame	48Y	Enclosure	Totally Enclosed Air Over
Thermal Protection	Automatic	Ambient Temperature	40 °C
UL	Recognized	CSA	Y
CE	N	Number of Speeds	2

Technical Specifications

Electrical Type	Permanent Split Capacitor	Starting Method	Across The Line
Poles	6	Rotation	Reversible
Mounting	Resilient Ring/Extended Studs	Motor Orientation	Any
Drive End Bearing	Ball	Opp Drive End Bearing	Ball
Frame Material	Rolled Steel	Shaft Type	Flat
Overall Length	11.11 in	Frame Length	4.50 in
Shaft Diameter	0.500 in	Shaft Extension	5.0 in
Connection Drawing	614131-308	Outline Drawing	UH1036NB-S01

This is an uncontrolled document once printed or downloaded and is subject to change without notice. Date Created:11/29/2022

GENERAL INFORMATION:

SHAFT RUNOUT: .001 [.025] T.I.R. PER INCH LENGTH OF EXTENSION

BEARINGS: BALL

MOUNTING POSITION: ALL ANGLE

ELECTRICAL DATA:

OVERLOAD PROTECTOR: AUTOMATIC RESET (T.I. 7AM 036)

LEADS: NO. 18 GA., .03 [.76] THK. CROSS-LINKED POLYETHELENE 125°C INSUL.

GROUND LEAD: NO. 18 GA., .03 [.76] THK. (GREEN) INSUL.

NOTE:

- SPLIT RINGS 615035 4x TO BE SHIPPED WITH EACH MOTOR

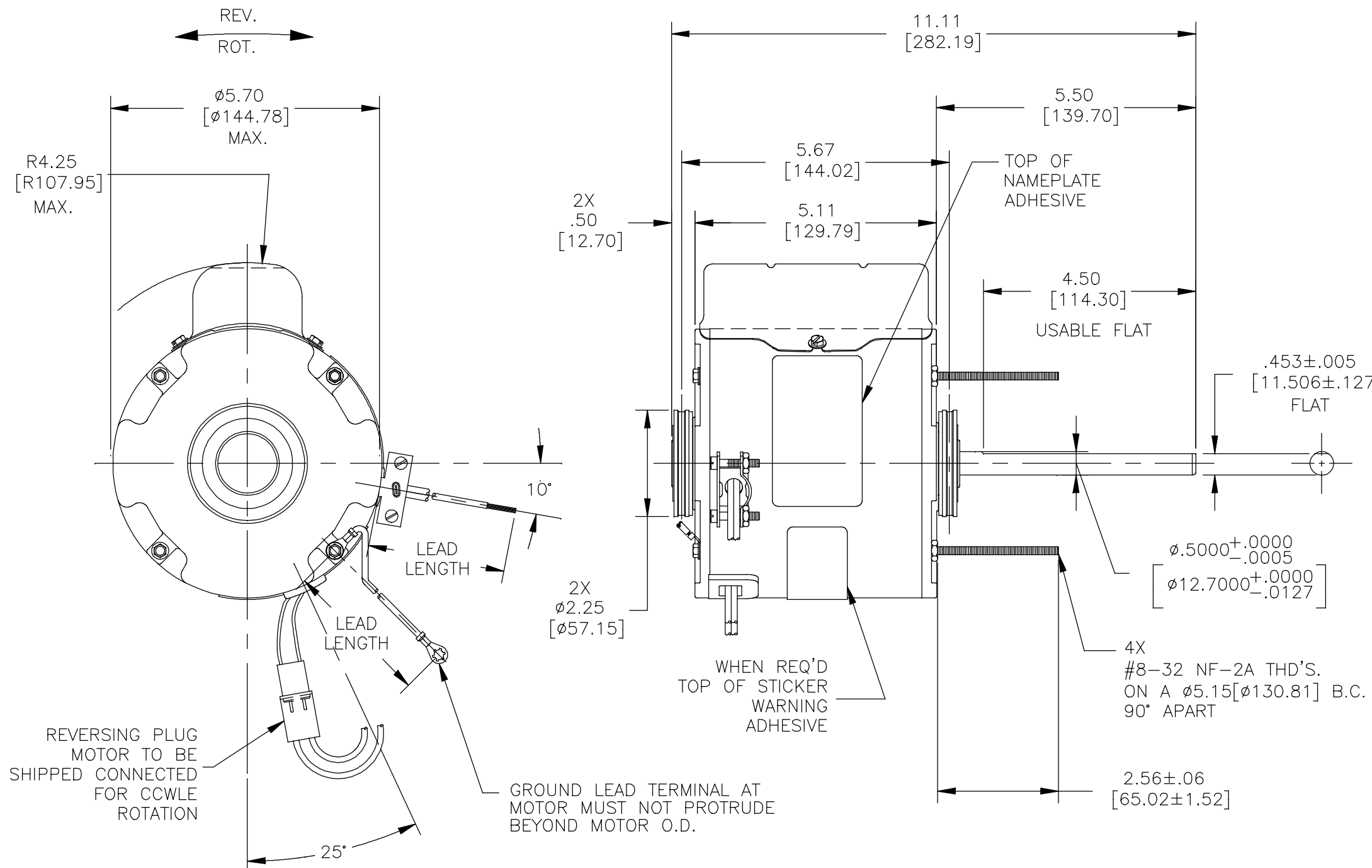

NAMEPLATE DATA:

MODEL NO.: F48U72A01
 CUST. P/N: UH1036NB
 HP: 1/3
 ROT.: REVERSIBLE
 RPM: 1100 (2 SPD)
 TYPE: UF
 FRAME: 48Y
 VOLTS: 115
 PH: 1
 AMPS: 4.3-1.8
 HZ: 60
 INS.: B
 AMB.: 40°C
 DUTY: AIR OVER
 CAP.: 6 MFD/370V
 ENCL: ENCLOSED
 UL LOGO
 CSA LOGO
 THERMALLY PROTECTED

EXTERNAL CONNECTION DIAGRAM

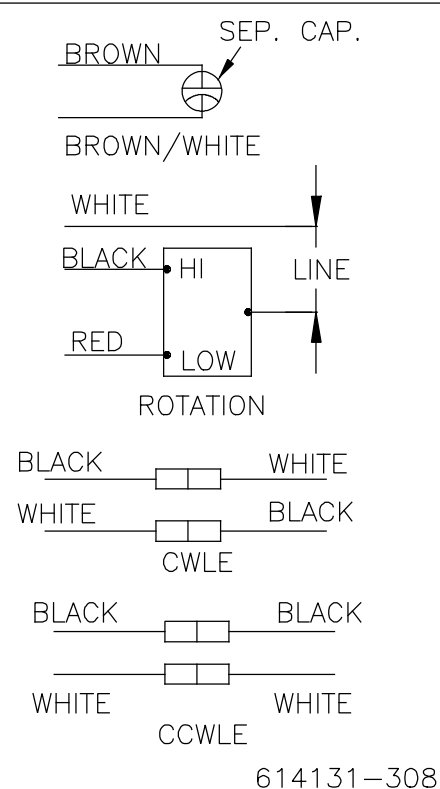

614131-308

PERFORMANCE CURVE NO.	TORQUE @ 1100 RPM (25°C)	APPROVED SAMPLE	UL COMPONENT		CSA	
			FILE #	CCN #	FILE #	CLASS #
C32229	22.5 OZ. FT.	0442349A	E46412	PRGY2	LR43341	4211-01

COLOR	LENGTH	TERMINAL OR STRIP LENGTH
GREEN(GRD)	11/13 [279/330]	#10 EYELET
BLACK/WHITE	3/5 [76/127]	REVERSING PLUG
WHITE	58/62 [1473/1575]	.60[15.24] SKIN
RED	58/62 [1473/1575]	.60[15.24] SKIN
BLACK	58/62 [1473/1575]	.60[15.24] SKIN
BROWN/WHITE	CONNECTED TO CAPACITOR	.25[6.35] FLAG
BROWN	CONNECTED TO CAPACITOR	.25[6.35] FLAG

REGAL-BELOIT CORPORATION (RBC) PROVIDES TECHNICAL ASSISTANCE TO OUR CUSTOMERS IN SEVERAL AREAS. SINCE RBC DOES NOT RECEIVE ALL DATA CONCERNING THE USE AND APPLICATION OF THE MOTOR, THE SUITABILITY OF THE MOTOR FOR THE APPLICATION MUST BE DETERMINED BY THE CUSTOMER.

DIMENSIONS WITHOUT TOLERANCES ARE FOR REFERENCE ONLY.

MAIN FRAME - OLE	ENCLOSED
END FRAME - OLE	ENCLOSED
MAIN FRAME - LE	ENCLOSED
END FRAME - LE	ENCLOSED

CUSTOMER	DISTRIBUTION SERVICE
----------	----------------------

DRAWING REVISION C	REVISION BY GELINE.ZHAO	DATE 08-22-2018
ECO	APPROVED BY DEXIAN.LI	DATE 08-22-2018
ECO DESCRIPTION SEE ECO		

DRAWN BY: G.ZHAO
DATE: 12-13-2016
APPROVED BY: J.ZHU
DATE: 12-13-2016
REFERENCE
THIRD ANGLE PROJECTION

Regal Beloit America, Inc.	
DESCRIPTION	MODEL-RFHP-48FR OUTLINE
MATERIAL	PROCESS/FINISH
SIZE DWG NO	UH1036NB
SHEET	1

COPYRIGHT REGAL-BELOIT AMERICA, INC. ALL RIGHTS RESERVED. PROPRIETARY AND CONFIDENTIAL INFORMATION - THIS DOCUMENT IS THE PROPERTY OF REGAL-BELOIT AMERICA, INC. (OWNER) AND CONTAINS OWNER'S PROPRIETARY INFORMATION. ANY PERSON, CORPORATION OR OTHER FIRM RECEIVING IT IS DEEMED, BY RECEIVING IT, TO AGREE THAT IT, AND/OR ANY PART OF IT, SHALL NOT BE DISCLOSED TO ANY PERSON, CORPORATION OR OTHER ENTITY, DUPLICATED, AND/OR USED, EXCEPT AS EXPRESSLY APPROVED IN WRITING IN ADVANCE BY OWNER. THIS DOCUMENT SHALL BE RETURNED TO OWNER UPON REQUEST. IT MAY BE SUBJECT TO CERTAIN RESTRICTIONS UNDER APPLICABLE EXPORT CONTROL LAWS AND REGULATIONS.

REV	ECO	REV BY	DATE	APPD	DATE
B	ECO-0021670	jrupert	07-22-2011	jrupert	07-22-2011

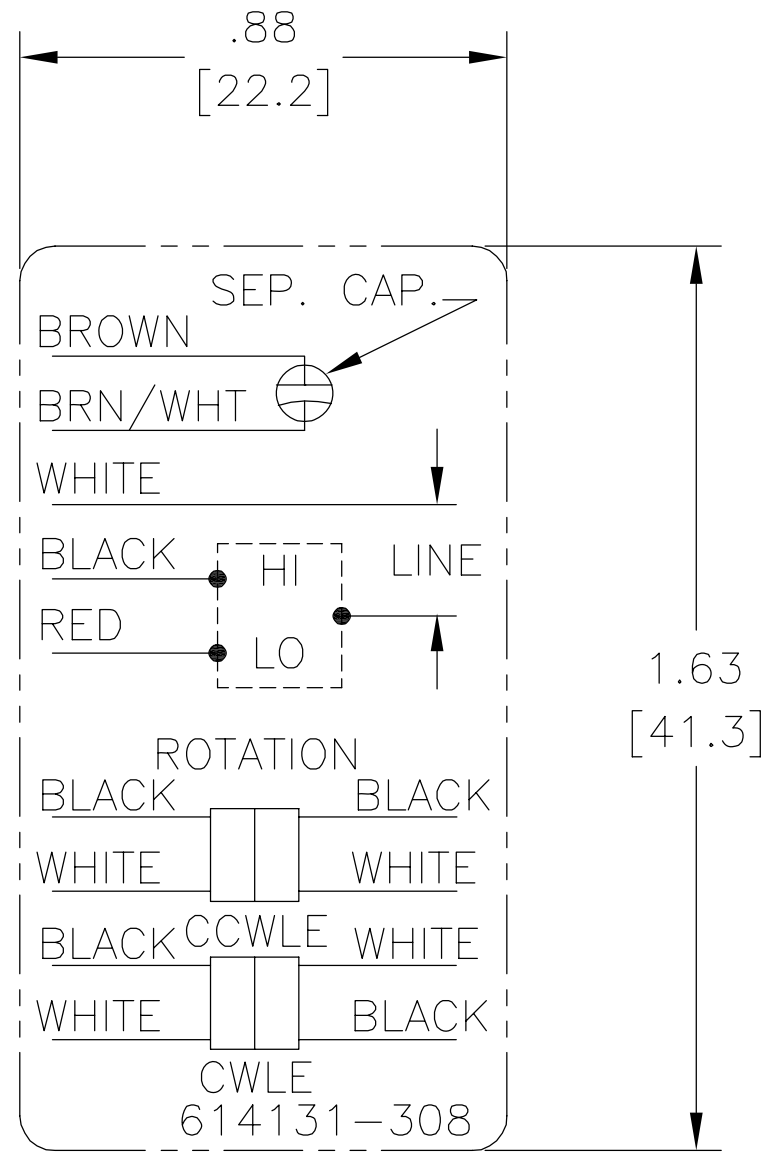

NOTES:

1. FOR USE WITH 614129 NAMEPLATE BLANK
2. — — — — — INDICATES DIMENSION LIMITS
3. DIE TO BE MADE FROM MASTER SUPPLIED BY A. O. SMITH CORPORATION
4. DIE MUST PRODUCE A LEGIBLE IMPRESSION.

GEOMETRIC CHARACTERISTICS & SYMBOLS ▭ FLATNESS — STRAIGHTNESS ∠ ANGULARITY ⊥ PERPENDICULARITY (SQUARENESS) // PARALLELISM ○ ROUNDNESS (CIRCULARITY) ⊘ CYLINDRICITY △ PROFILE OF ANY SURFACE ∩ PROFILE OF ANY LINE ↑ RUNOUT ⊕ TRUE POSITION ◎ CONCENTRICITY = SYMMETRY	UNLESS OTHERWISE SPECIFIED DIM. TOLERANCES ARE AS FOLLOWS: INCH X XX XXX XXXX mm ±0.5 ±0.13 ±0.013 ANG. ±.50 DEG REMOVE BURRS & BREAK SHARP EDGES: INCH .003-.015 mm 0.1-0.4 CORNER FILLETS TO: INCH .020 mm 0.5 MACHINE SURFACES: INCH 125 mm 3.2 METRIC DIMS. SHOWN IN [BRACKETS]	DR BY:	jrupert	07-22-2011	ELECTRICAL PRODUCTS COMPANY A DIVISION OF A. O. SMITH CORPORATION		
		APPD:	jrupert	07-22-2011			
		THIRD ANGLE PROJECTION		EDS DATE	02-22-2008	DESCRIPTION	CONN DIAGRAM NAMEPLATE
		CONFIDENTIAL: THIS DRAWING AND ITS INFORMATION ARE THE EXCLUSIVE AND CONFIDENTIAL PROPERTY OF A.O. SMITH CORP. AND ARE NOT TO BE DISCLOSED, DUPLICATED, DISTRIBUTED OR OTHERWISE USED WITHOUT THE WRITTEN CONSENT OF A.O. SMITH CORP. -ALL RIGHTS RESERVED. ASME Y14.5M 1994		SIZE	A	DWG NO	614131-308
		SCALE	NONE	SHEET 1			

REVISION:	ECO	REVISADO POR:	FECHA:	APROBADO POR:	FECHA:
B	ECO-0021670	jrupert	07-22-2011	jrupert	07-22-2011

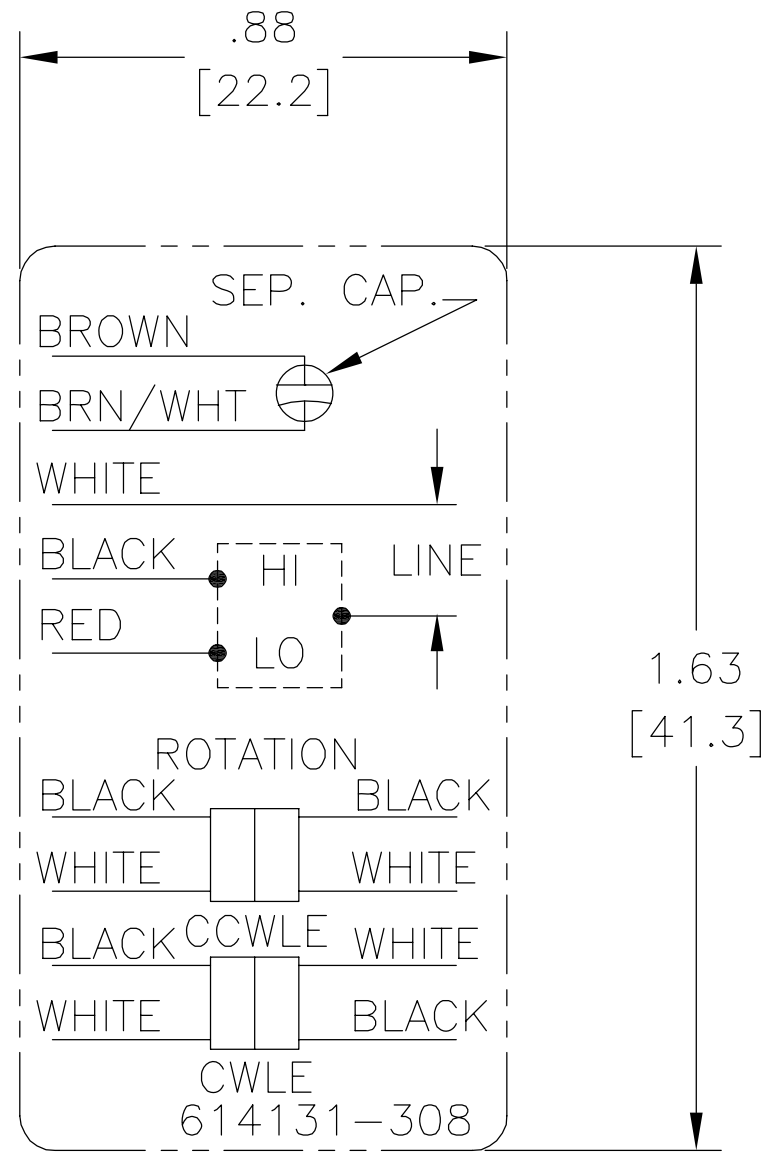

NOTES:

1. FOR USE WITH 614129 NAMEPLATE BLANK
2. ——— ——— INDICATES DIMENSION LIMITS
3. DIE TO BE MADE FROM MASTER SUPPLIED BY A. O. SMITH CORPORATION
4. DIE MUST PRODUCE A LEGIBLE IMPRESSION.

CARACTERISTICAS DE GEOMETRIA Y SIMBOLOS

- PLANICIDAD
- RECTITUD
- ∠ ANGULARIDAD
- ⊥ PERPENDICULARIDAD (A ESCUADRA)
- // PARALELISMO
- REDONDEZ (CIRCULARIDAD)
- ⊘ CILINDRICIDAD
- ⊖ PERFIL DE CUALQUIER SUPERFICIE
- ⌒ PERFIL DE CUALQUIER LINEA
- ↑ VARIACION
- ⊕ POSICION REAL
- ◎ CONCENTRICIDAD
- ≡ SIMETRIA

A MENOS QUE SE ESPECIFIQUE DE OTRA MANERA, LAS TOLERANCIAS DE LAS DIMS; SON LAS SIGUIENTES:

	X	XX	XXX	XXXX
PULG	±.1	±.02	±.005	±.0005
mm	±0.5	±0.13	±0.013	

ANG. ±.50 GRADOS
ELIMINAR REBABAS Y ORILLAS FILOSAS DEL BORDE.

PULG	.003-.015	mm	0.1-0.4
------	-----------	----	---------

FILETEAR ESQUINA: PULG .020 mm 0.5
MAQUINAR SUPERFICIES
PULG 125 mm 3.2

DIMS METRICAS MOSTRADAS [PARENTESIS]

DIBUJADO POR:	jrupert	07-22-2011
APROBADO POR:	jrupert	07-22-2011
TERCER ANGULO DE PROYECCION	⊕	FECHA EDS: 02-22-2008 REV. FORMATO: F
CONFIDENCIAL: ESTE DIBUJO Y SU INFORMACION SON PROPIEDAD DE USO EXCLUSIVO Y CONFIDENCIAL DE A.O.SMITH CORP. Y NO DEBERAN SER REVELADOS, DUPLICADOS, DISTRIBUIDOS O USARSE DE OTRA MANERA SIN EL CONSENTIMIENTO ESCRITO DE A.O. SMITH CORP. -TODOS LOS DERECHOS RESERVADOS.ASME Y14.5M 1994		

 ELECTRICAL PRODUCTS COMPANY <small>A DIVISION OF A. O. SMITH CORPORATION</small>	
DESCRIPCION: CONN DIAGRAM NAMEPLATE	
TAMAÑO: A	NUMERO DE DIBUJO: 614131-308
ESCALA: NONE	HOJA: 1

版本	ECO	编制	日期	批准	日期
B	ECO-0021670	jrupert	07-22-2011	jrupert	07-22-2011

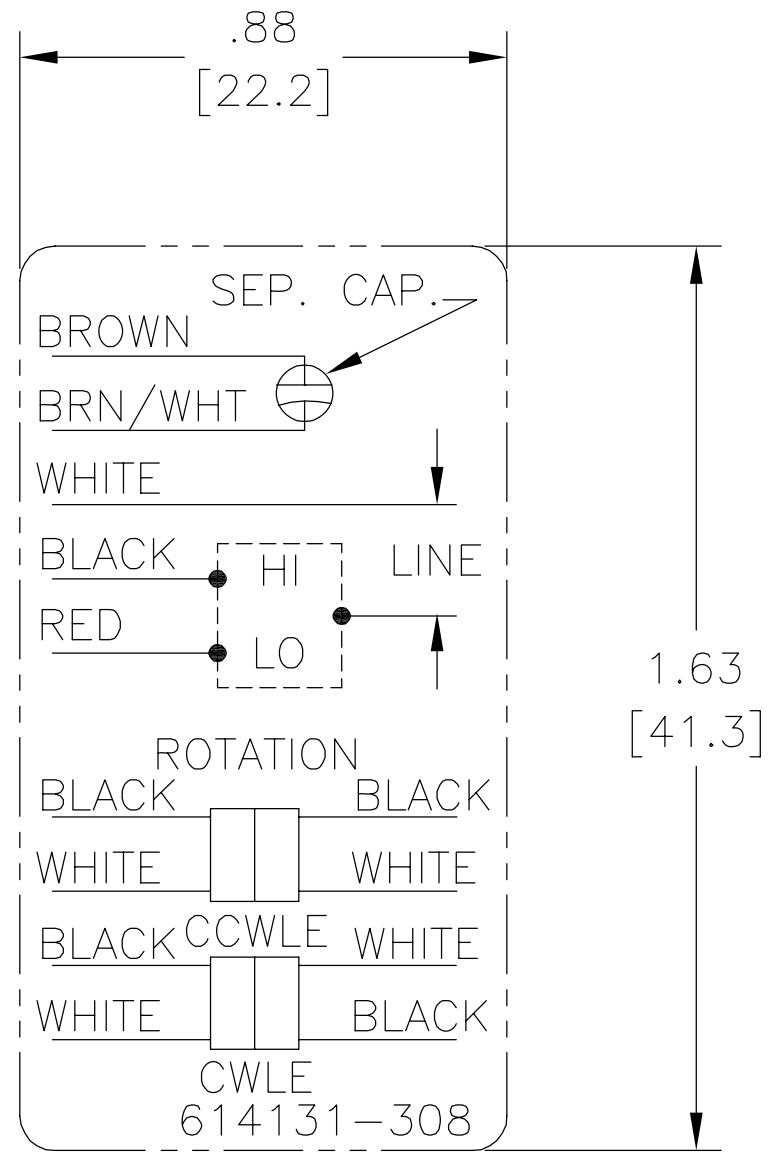

NOTES:

1. FOR USE WITH 614129 NAMEPLATE BLANK
2. ———— INDICATES DIMENSION LIMITS
3. DIE TO BE MADE FROM MASTER SUPPLIED BY A. O. SMITH CORPORATION
4. DIE MUST PRODUCE A LEGIBLE IMPRESSION.

形位公差 □ 平面度 — 直线度 ∠ 倾斜度 ⊥ 垂直度 // 平行度 ○ 圆度 ⊘ 圆柱度 △ 面轮廓度 ∩ 线轮廓度 ↗ 圆跳动 ⊕ 位置度 ◎ 同轴度 ≡ 对称度	除另有注明 尺寸公差如下: 英寸 X XX XXX XXXX ±.1 ±.02 ±.005 ±.0005 毫米 ±0.5 ±0.13 ±0.013 角度 ±.50 度 清理毛刺和尖棱 英寸 .003-.015 毫米 0.1-0.4 内圆角 英寸 .020 毫米 0.5 表面粗糙度 英制 125 米制 3.2 米制尺寸显示在 []
---	--

绘图:	jrupert	07-22-2011
批准:	jrupert	07-22-2011
第三角投影		图纸格式发布日期 02-22-2008 图纸格式版本 F
机密: 本图纸及相关信息所有权归A. O. SMITH公司所有。 未经A. O. SMITH公司书面授权, 不得泄露、复制、传播或作 其他用途。—版权所有		
ASME Y14.5M 1994		

		ELECTRICAL PRODUCTS COMPANY <small>A DIVISION OF A. O. SMITH CORPORATION</small>	
名称 CONN DIAGRAM NAMEPLATE			
图幅	A	图号	614131-308
比例	NONE	页号	1