

# PRODUCT INFORMATION PACKET



Model No: U6433

Catalog No: U6433

Unit Heater Motor, 1/15 HP, 1 Ph, 60 Hz, 115 V, 1050 RPM, 1 Speed, 42 Frame, ENCLOSED



Regal and Century are trademarks of Regal Rexnord Corporation or one of its affiliated companies.

©2022 Regal Rexnord Corporation, All Rights Reserved. MC017097E





**Nameplate Specifications**

Output HP	1/15 Hp	Output KW	0.05 kW
Frequency	60 Hz	Voltage	115 V
Current	3.3 A	Speed	1050 rpm
Service Factor	1	Phase	1
Duty	Air Over	Insulation Class	B
Frame	42Y	Enclosure	Totally Enclosed
Thermal Protection	Automatic	Ambient Temperature	40 °C
UL	Recognized	CSA	Y
CE	N	Number of Speeds	1

**Technical Specifications**

Electrical Type	Shaded Pole	Starting Method	Across The Line
Poles	6	Rotation	Counterclockwise Lead End
Mounting	Extended Studs	Motor Orientation	Horizontal
Drive End Bearing	Sleeve	Opp Drive End Bearing	Sleeve
Frame Material	Na	Shaft Type	Flat
Overall Length	6.72 in	Shaft Diameter	0.500 in
Shaft Extension	1.8 in		
Connection Drawing	261B865F01	Outline Drawing	U6433-S01

This is an uncontrolled document once printed or downloaded and is subject to change without notice. Date Created:11/28/2022

GENERAL INFORMATION:

SHAFT RUNOUT: .001 [.03] T.I.R. PER INCH LENGTH OF EXTENSION.

END PLAY: .010 [.25] TO .063 [1.6]

BEARINGS: SLEEVE

MOUNTING POSITION: HORIZONTAL

ELECTRICAL DATA:

OVERLOAD PROTECTOR: AUTOMATIC RESET (SENSATA 7AM 034)

LEADS: NO. 18 GA., .03 [.8] THK., PVC 125°C INSUL.

NOTE:  
DISTRIBUTION: CUST. P/N: U6433  
GRAINGER: CUST. P/N: 4UU91

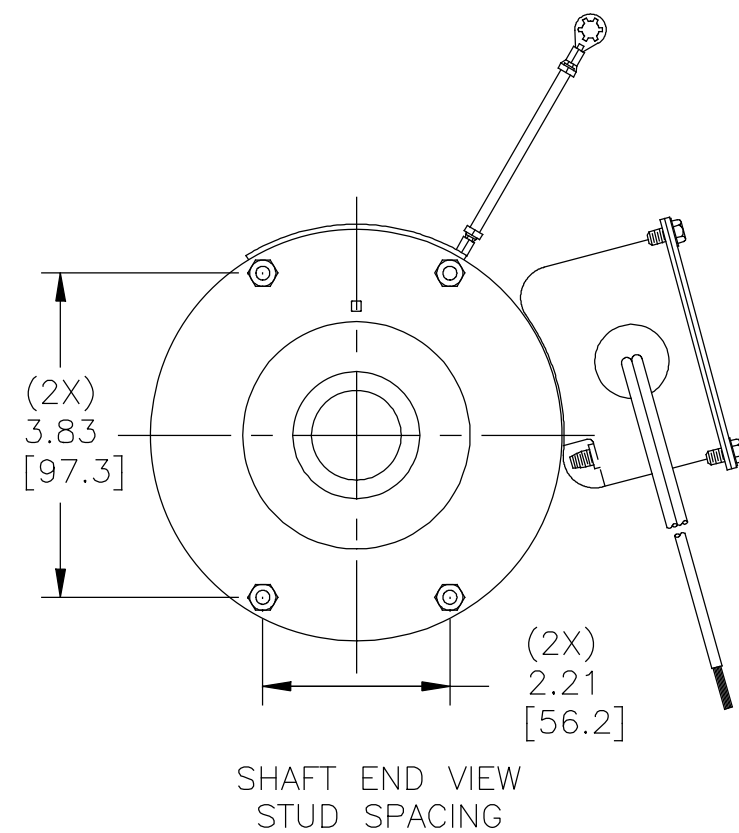
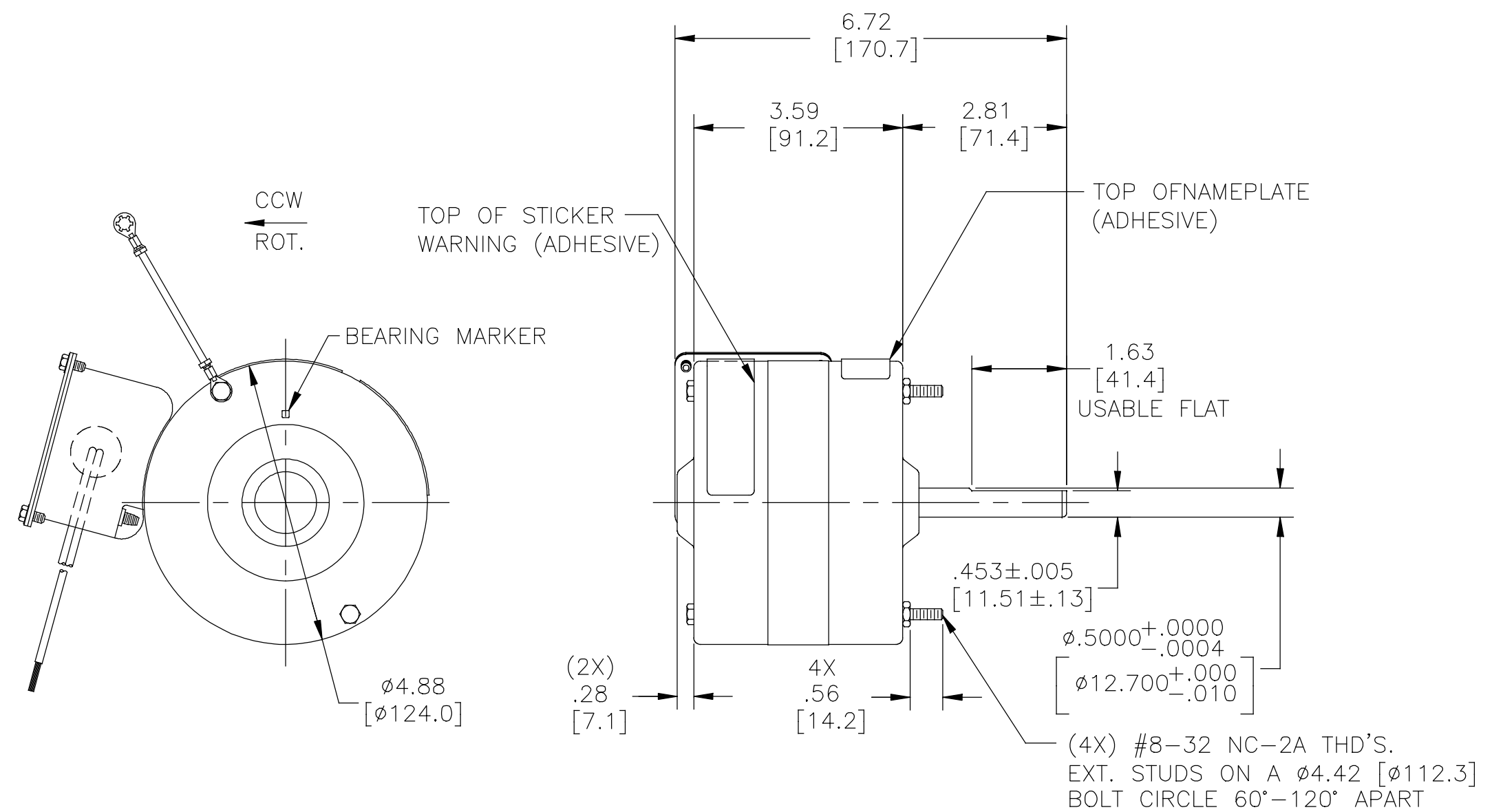

REGAL-BELOIT CORPORATION (RBC) PROVIDES TECHNICAL ASSISTANCE TO OUR CUSTOMERS IN SEVERAL AREAS. SINCE RBC DOES NOT RECEIVE ALL DATA CONCERNING THE USE AND APPLICATION OF THE MOTOR, THE SUITABILITY OF THE MOTOR FOR THE APPLICATION MUST BE DETERMINED BY THE CUSTOMER.

DIMENSIONS WITHOUT TOLERANCES ARE FOR REFERENCE ONLY.

GREEN (GRD.)	12.0/14.0 [304/356]	#10 EYELET
WHITE	6.0/8.0 [914/203]	.75 [19.1] STRIP
BLACK	6.0/8.0 [914/203]	.75 [19.1] STRIP
COLOR	LENGTH	TERMINAL OR STRIP LENGTH

MAIN-FR.-OLE	ENCLOSED
END FR.-OLE	ENCLOSED
MAIN FR.-LE	ENCLOSED
END FR.LE	ENCLOSED

CUSTOMER	DISTRIBUTION SERVICES
----------	-----------------------

NAMEPLATE DATA:	EXTERNAL CONNECTION DIAGRAM
MODEL NO.: B42A92A01 CUST. P/N: [ ] HP: 1/15 ROT: CCWLE RPM: 1050 TYPE: FE FRAME: 42Y VOLTS: 115 PH: 1 AMPS: 3.3 HZ: 60 INS: B AMB: 40°C DUTY: AIR OVER CSA LOGO UL LOGO THERMALLY PROTECTED TYPE C	SEE NOTE BLK ———— LINE WHT ————

PERFORMANCE CURVE NO.	TORQUE @ 1050 RPM (25°C)	APPROVED SAMPLE	UL COMPONENT FILE #	CCN #	CSA FILE #	CLASS #
C31135	8.3 OZ. FT.	94AC108C	E46412	PRGY2	LR43341	4211-01

DRAWING REVISION	REVISION BY	DATE
J	J. RUPERT	04-30-2020
ECO	APPROVED BY	DATE
ECO-0185890	J. RUPERT	04-30-2020
ECO DESCRIPTION		
CORRECTED THRU BOLT EXTENSION		

COPYRIGHT REGAL BELOIT AMERICA, INC. ALL RIGHTS RESERVED. PROPRIETARY AND CONFIDENTIAL INFORMATION - THIS DOCUMENT IS THE PROPERTY OF REGAL BELOIT AMERICA, INC. (OWNER) AND CONTAINS OWNER'S PROPRIETARY INFORMATION. ANY PERSON, CORPORATION OR OTHER FIRM RECEIVING IT IS DEEMED, BY RECEIVING IT, TO AGREE THAT IT, AND/OR ANY PART OF IT, SHALL NOT BE DISCLOSED TO ANY PERSON, CORPORATION OR OTHER ENTITY, DUPLICATED, AND/OR USED, EXCEPT AS EXPRESSLY APPROVED IN WRITING IN ADVANCE BY OWNER. THIS DOCUMENT SHALL BE RETURNED TO OWNER UPON REQUEST. IT MAY BE SUBJECT TO CERTAIN RESTRICTIONS UNDER APPLICABLE EXPORT CONTROL LAWS AND REGULATIONS.

DRAWN BY: J.W.	DATE: 08-19-2004	Regal Beloit America, Inc.
APPROVED BY: J.W.	DATE: 08-19-2004	
REFERENCE	MATERIAL	DESCRIPTION
		MODEL-RFHP-42FR OUTLINE
THIRD ANGLE PROJECTION	SIZE DWG NO	PROCESS/FINISH
	C U6433	
		SHEET 1

REV	ECO	REV BY	DATE	APPD	DATE
T	ECO-0018824	J.HESS	04-15-2011	J.HESS	04-15-2011

FOR SINGLE SPEED ONLY  
COLOR OF LEADS TO BE OPTIONAL

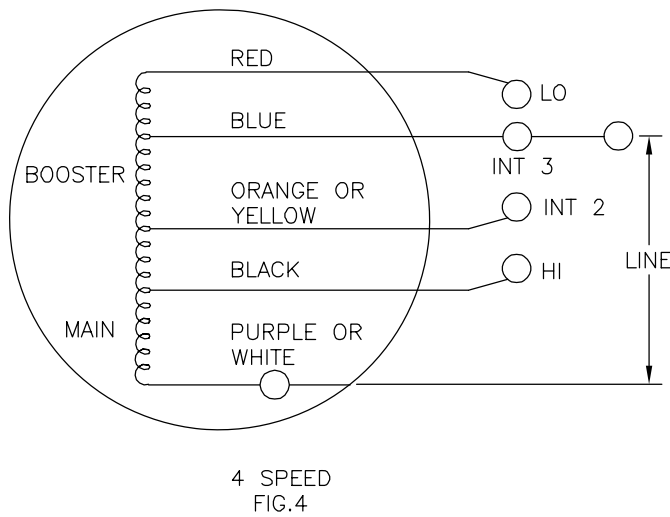
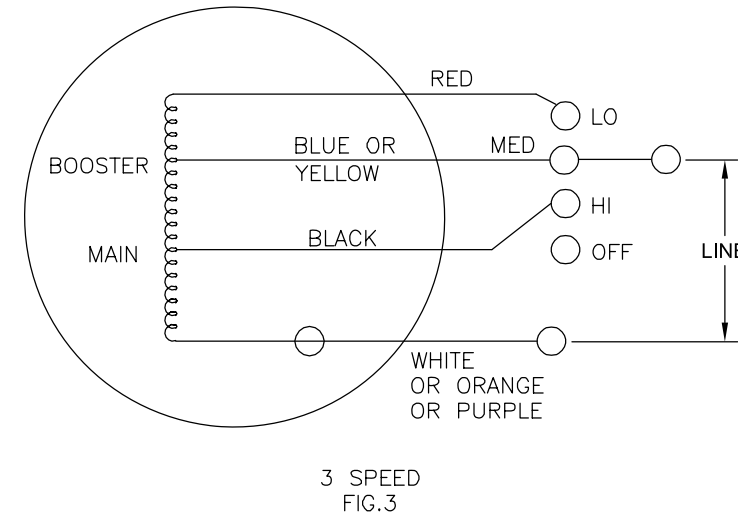
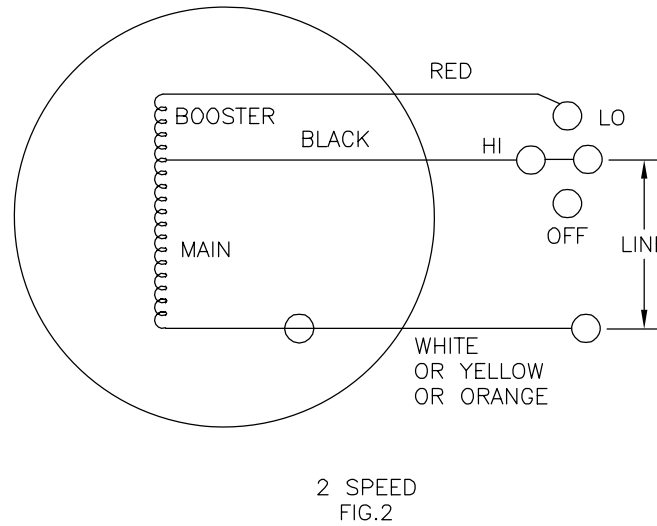
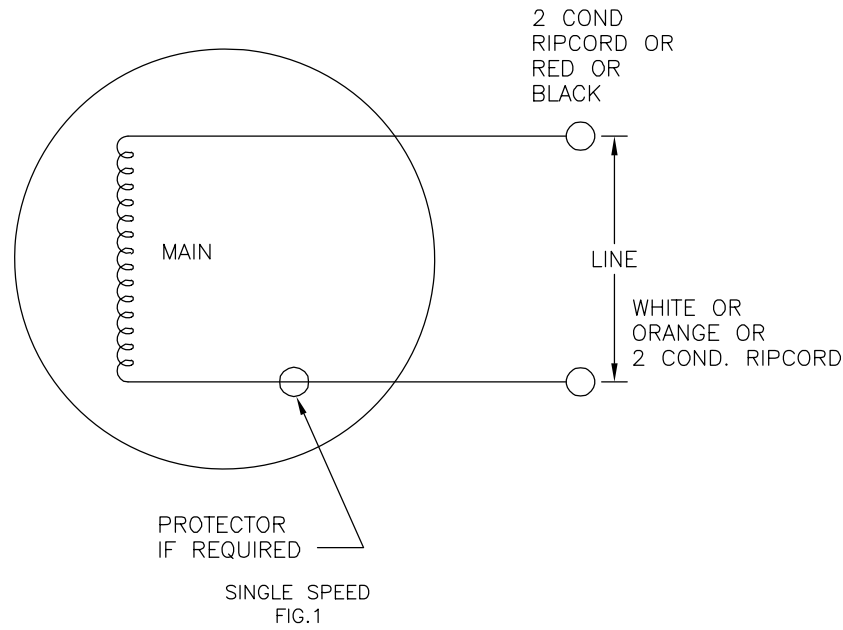

QUALITY CONTROL NOTE:  
TO CHECK THE WINDINGS FOR OPENS VERIFY THE CONTINUITY AS OUTLINED BELOW.  
FIG.1 BETWEEN WHITE AND BLACK OR WHITE & RED LEADS  
FIG.2, 3 & 4, BETWEEN THE WHITE & RED LEADS.

GEOMETRIC CHARACTERISTICS & SYMBOLS

- ▭ FLATNESS
- STRAIGHTNESS
- ∠ ANGULARITY
- ⊥ PERPENDICULARITY (SQUARENESS)
- // PARALLELISM
- ROUNDNESS (CIRCULARITY)
- ⊘ CYLINDRICITY
- △ PROFILE OF ANY SURFACE
- ∩ PROFILE OF ANY LINE
- ↗ RUNOUT
- ⊕ TRUE POSITION
- ⊙ CONCENTRICITY
- ≡ SYMMETRY

UNLESS OTHERWISE SPECIFIED  
DIM. TOLERANCES ARE AS FOLLOWS:

INCH	±.1	±.02	±.005	±.0005
mm	±0.5	±0.13	±0.013	

ANG. ±.50 DEG  
REMOVE BURRS & BREAK SHARP EDGES:  
INCH .003-.015 mm 0.1-0.4  
CORNER FILLETS TO:  
INCH .020 mm 0.5  
MACHINE SURFACES:  
INCH 125 mm 3.2  
METRIC DIMS. SHOWN IN [BRACKETS]

DR BY:	KLINE	10-24-1966
APPD:	RDS	10-27-1966
THIRD ANGLE PROJECTION		EDS DATE 02-22-2008 FORMAT REV F
CONFIDENTIAL: THIS DRAWING AND ITS INFORMATION ARE THE EXCLUSIVE AND CONFIDENTIAL PROPERTY OF A.O. SMITH CORP. AND ARE NOT TO BE DISCLOSED, DUPLICATED, DISTRIBUTED OR OTHERWISE USED WITHOUT THE WRITTEN CONSENT OF A.O. SMITH CORP. -ALL RIGHTS RESERVED. ASME Y14.5M 1994		

<b>ACSmith</b> Innovation has a name.		<b>ELECTRICAL PRODUCTS COMPANY</b> A DIVISION OF A. O. SMITH CORPORATION	
DESCRIPTION CONN DIAGRAM-EXTERNAL			
SIZE C	DWG NO 261B865F01	SHEET 1	
SCALE NONE			

4

3

2

1

REVISION:	ECO	REVISADO POR:	FECHA:	APROBADO POR:	FECHA:
T	ECO-0018824	J.HESS	04-15-2011	J.HESS	04-15-2011

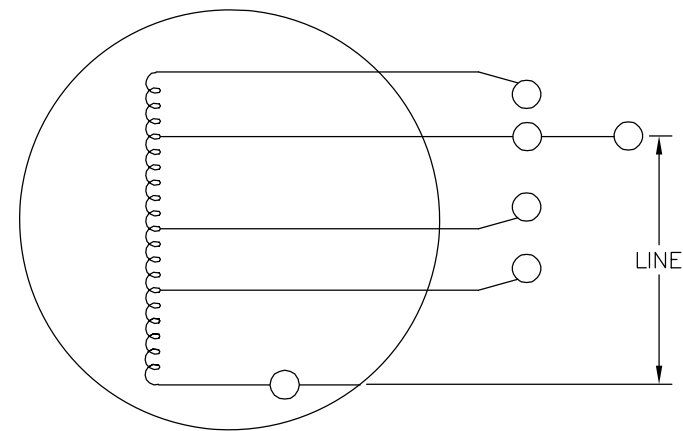
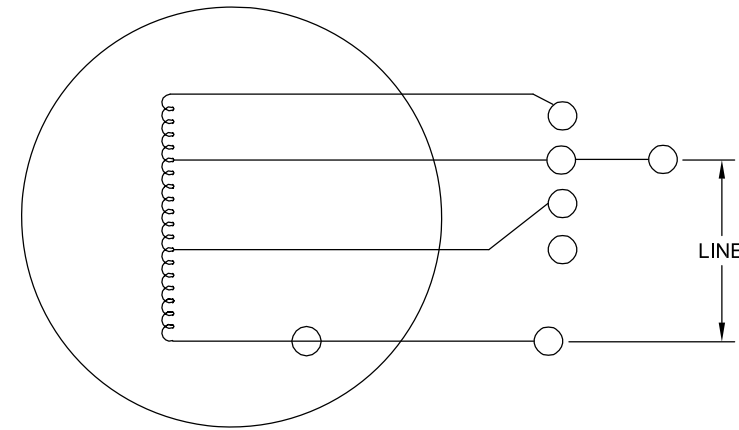
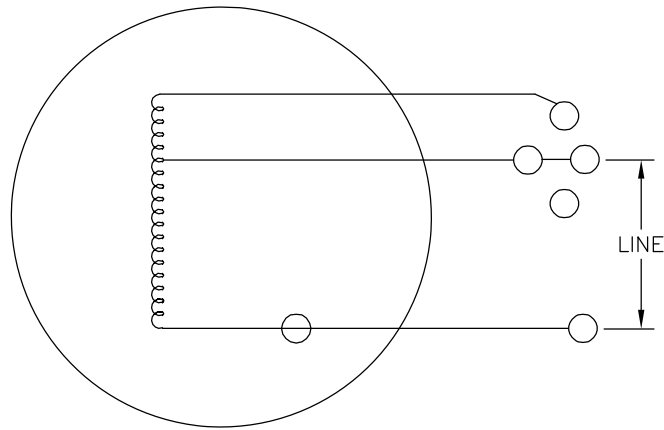
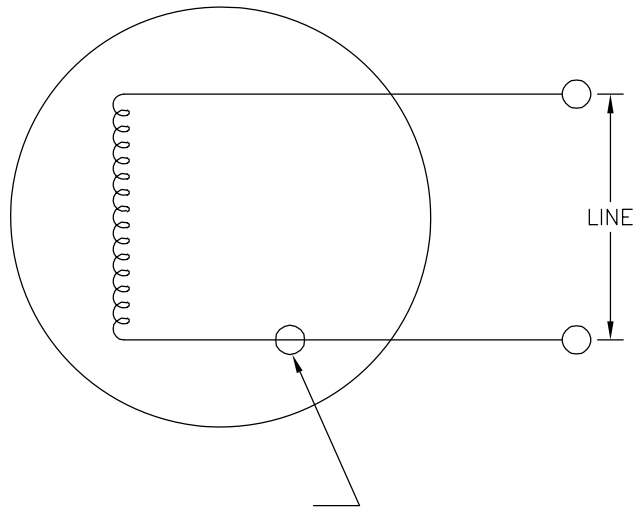

CARACTERISTICAS DE GEOMETRIA Y SIMBOLOS

- ▭ PLANICIDAD
- RECTITUD
- ∠ ANGULARIDAD
- ⊥ PERPENDICULARIDAD (A ESCUADRA)
- // PARALELISMO
- REDONDEZ (CIRCULARIDAD)
- ⊘ CILINDRICIDAD
- △ PERFIL DE CUALQUIER SUPERFICIE
- ∇ PERFIL DE CUALQUIER LINEA
- ↑ VARIACION
- ⊕ POSICION REAL
- ◎ CONCENTRICIDAD
- ≡ SIMETRIA

A MENOS QUE SE ESPECIFIQUE DE OTRA MANERA, LAS TOLERANCIAS DE LAS DIMS; SON LAS SIGUIENTES:

PULG	±.1	±.02	±.005	±.0005
mm	±0.5	±0.13	±0.013	

ANG. ± 50 GRADOS  
ELIMINAR REBABAS Y ORILLAS FILOSAS DEL BORDE.

PULG	.003-.015	mm	0.1-0.4
------	-----------	----	---------

FILETEAR ESQUINA: PULG .020 mm 0.5  
MAQUINAR SUPERFICIES  
PULG 125 mm .32

DIMS METRICAS MOSTRADAS [PARENTESIS]

DIBUJADO POR:	KLINE	10-24-1966
APROBADO POR:	RDS	10-27-1966
TERCER ANGULO DE PROYECCION	⊕	FECHA EDS: 02-22-2008 REV. FORMATO: F
CONFIDENCIAL: ESTE DIBUJO Y SU INFORMACION SON PROPIEDAD DE USO EXCLUSIVO Y CONFIDENCIAL DE A.O.SMITH CORP. Y NO DEBERAN SER REVELADOS, DUPLICADOS, DISTRIBUIDOS O USARSE DE OTRA MANERA SIN EL CONSENTIMIENTO ESCRITO DE A.O. SMITH CORP. -TODOS LOS DERECHOS RESERVADOS.ASME Y14.5M 1994		



**ELECTRICAL PRODUCTS COMPANY**  
A DIVISION OF A. O. SMITH CORPORATION

DESCRIPCION:

**CONN DIAGRAM-EXTERNAL**

TAMAÑO: C	NUMERO DE DIBUJO: 261B865F01
ESCALA: NONE	HOJA: 1

4

3

2

1

4

3

2

1

版本	ECO	编制	日期	批准	日期
T	ECO-0018824	J.HESS	04-15-2011	J.HESS	04-15-2011

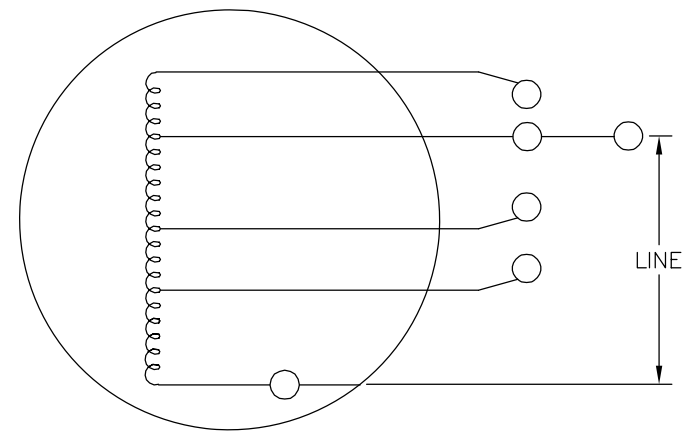
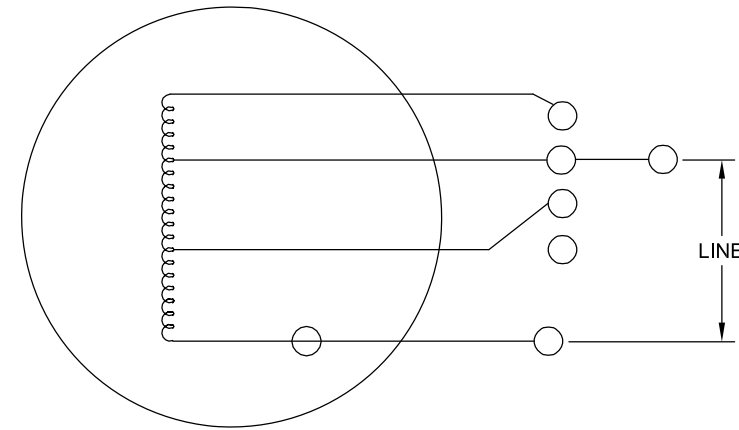
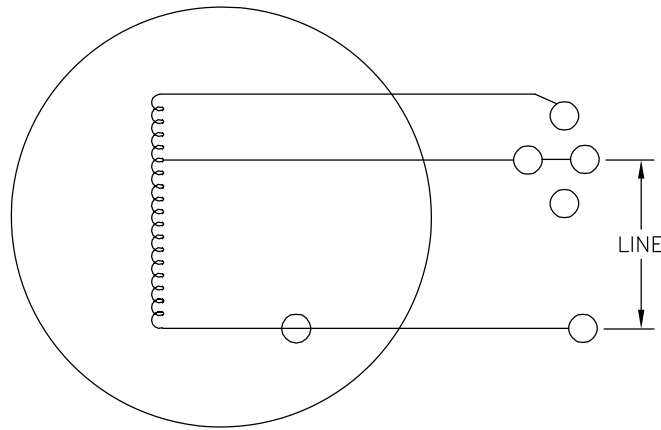
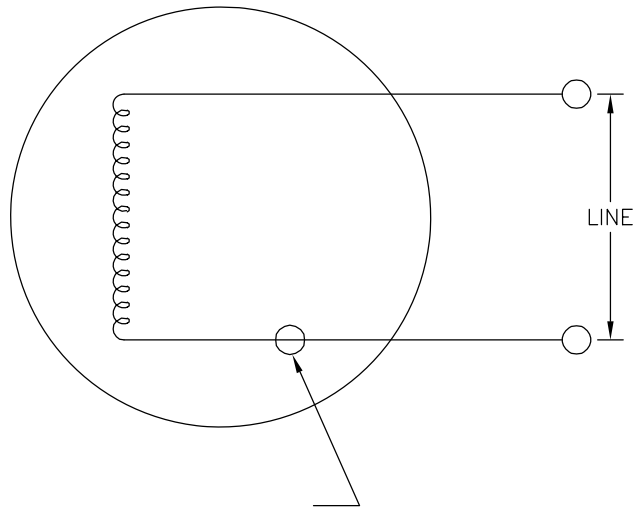

形位公差
□ 平面度
— 直线度
∠ 倾斜度
⊥ 垂直度
// 平行度
○ 圆度
⊘ 圆柱度
∩ 内圆角
△ 面轮廓度
∩ 线轮廓度
↗ 圆跳动
⊕ 位置度
⊙ 同轴度
≡ 对称度

除另有注明 尺寸公差如下:
英寸 X XX XXX XXXX
毫米 ±0.1 ±0.02 ±0.005 ±0.0005
毫米 ±0.5 ±0.13 ±0.013
角度 ±.50 度
清理毛刺和尖棱
英寸 .003-.015 毫米 0.1-0.4
内圆角
英寸 .020 毫米 0.5
表面粗糙度
英制 125 米制 3.2
米制尺寸显示在 [ ]

绘图:	KLINE	10-24-1966
批准:	RDS	10-27-1966
第三角投影		图纸格式发布日期 02-22-2008 图纸格式版本 F
机密: 本图纸及相关信息所有权归A. O. SMITH公司所有。 未经A. O. SMITH公司书面授权, 不得泄露、复制、传播或作 其他用途。—版权所有		
ASME Y14.5M 1994		

<b>ACSmith</b> Innovation has a name.		<b>ELECTRICAL PRODUCTS COMPANY</b> A DIVISION OF A. O. SMITH CORPORATION	
名称 CONN DIAGRAM-EXTERNAL			
图幅 C	图号 261B865F01		比例 NONE
			页号 1

4

3

2

1