

# PRODUCT INFORMATION PACKET



Model No: U6430  
Catalog No: U6430

Unit Heater Motor, 1/15 HP, 1 Ph, 60 Hz, 115 V, 1050 RPM, 1 Speed, 42 Frame, ENCLOSED



Regal and Century are trademarks of Regal Rexnord Corporation or one of its affiliated companies.  
©2022 Regal Rexnord Corporation, All Rights Reserved. MC017097E





**Nameplate Specifications**

Output HP	1/15 Hp	Output KW	0.05 kW
Frequency	60 Hz	Voltage	115 V
Current	3.3 A	Speed	1050 rpm
Service Factor	1	Phase	1
Duty	Air Over	Insulation Class	B
Frame	42Y	Enclosure	Totally Enclosed
Thermal Protection	Automatic	Ambient Temperature	40 °C
UL	Recognized	CSA	Y
CE	N	Number of Speeds	1

**Technical Specifications**

Electrical Type	Shaded Pole	Starting Method	Across The Line
Poles	6	Rotation	Counterclockwise Lead End
Mounting	Extended Studs	Motor Orientation	Horizontal
Drive End Bearing	Sleeve	Opp Drive End Bearing	Sleeve
Frame Material	Na	Shaft Type	Flat
Overall Length	6.79 in	Shaft Diameter	0.500 in
Shaft Extension	2.7 in		
Connection Drawing	261B865F01	Outline Drawing	12045-006-S01

This is an uncontrolled document once printed or downloaded and is subject to change without notice. Date Created:11/28/2022

4

3

2

1

REV	ECO	REV BY	DATE	APPD	DATE
C	0025582	I. ORTIZ	05-01-2012	D. BALDERRAMA	05-01-2012

GENERAL INFORMATION:

SHAFT RUNOUT: .001[.03] T.I.R. PER INCH LENGTH OF EXTENSION.  
 END PLAY: .010[.25] TO .063[1.60]  
 BEARINGS: SLEEVE  
 MOUNTING POSITION: HORIZONTAL  
 ELECTRICAL DATA:  
 OVERLOAD PROTECTOR: AUTOMATIC RESET (T.I. 7AM 304)  
 LEADS: NO. 18 GA., .03[.8] THK., CROSS-LINKED POLYETHYLENE 125°C INSUL.  
 GROUND LEAD: NO. 18 GA., .03[.8] THK., (GREEN) INSUL.

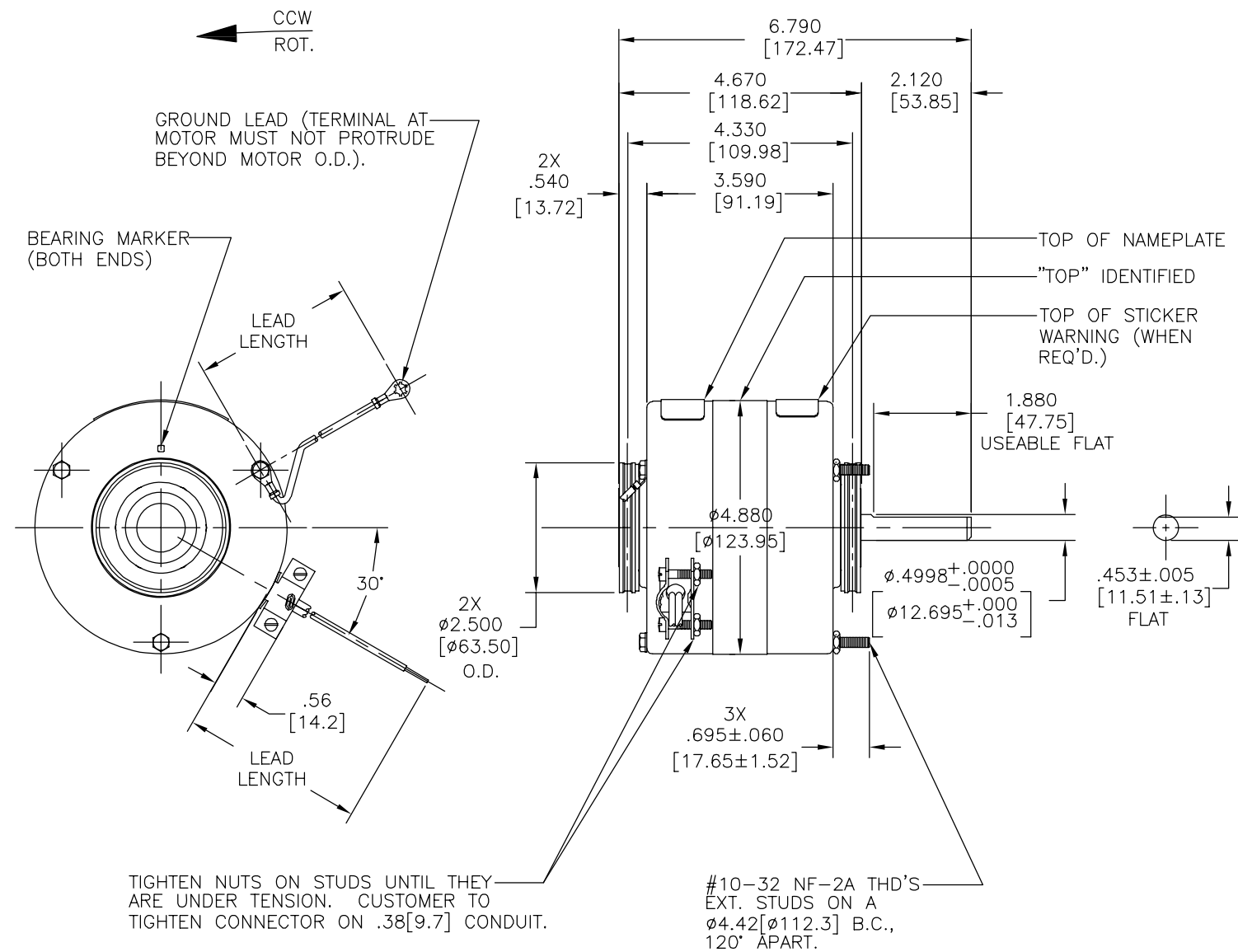

NAMEPLATE DATA:

EXTERNAL CONNECTION DIAGRAM

MODEL NO.: B42A30A01  
 CUST. P/N: U6430  
 HP: 1/15  
 ROT.: CCWLE  
 RPM: 1050  
 TYPE: FE  
 FRAME: 42Y  
 VOLTS: 115  
 PH: 1  
 AMPS: 3.3  
 HZ: 60  
 INS: B  
 AMB.: 40°C  
 DUTY: AIR OVER  
 CODE: -  
 CAP.: -  
 ENCL: -  
 UL LOGO  
 CSA LOGO  
 THERMALLY PROTECTED  
 TYPE C

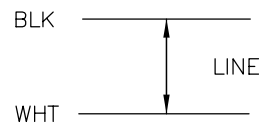

GREEN(GRD)	15/17 [381/432]	#10 EYELET
BLACK	35/38 [889/965]	.50 [12.7] SKIN
WHITE	35/38 [889/965]	.50 [12.7] SKIN
COLOR	LENGTH	TERMINAL OR STRIP LENGTH

MAIN FRAME - OLE	ENCLOSED
END FRAME - OLE	ENCLOSED
MAIN FRAME - LE	ENCLOSED
END FRAME - LE	ENCLOSED

CUSTOMER	DISTRIBUTION SERVICE
----------	----------------------

PERFORMANCE CURVE NO.	TORQUE @1050 RPM (25°C)	APPROVED SAMPLE	UL COMPONENT FILE #	CCN #	CSA FILE #	CLASS #
C31135	8.3 OZ. FT.	94AC108C	E46993	PRGY2	LR43341	260-φ-0

GEOMETRIC CHARACTERISTICS & SYMBOLS  
 ▮ FLATNESS  
 - STRAIGHTNESS  
 ∠ ANGULARITY  
 ⊥ PERPENDICULARITY (SQUARENESS)  
 // PARALLELISM  
 ○ ROUNDNESS (CIRCULARITY)  
 ∅ CYLINDRICITY  
 △ PROFILE OF ANY SURFACE  
 ∩ PROFILE OF ANY LINE  
 ↗ RUNOUT  
 ⊕ TRUE POSITION  
 ⊙ CONCENTRICITY  
 = SYMMETRY  
 ASME Y14.5M 1994

REGAL-BELOIT CORPORATION (RBC) PROVIDES TECHNICAL ASSISTANCE TO OUR CUSTOMERS IN SEVERAL AREAS. SINCE RBC DOES NOT RECEIVE ALL DATA CONCERNING THE USE AND APPLICATION OF THE MOTOR, THE SUITABILITY OF THE MOTOR FOR THE APPLICATION MUST BE DETERMINED BY THE CUSTOMER.  
 DIMENSIONS WITHOUT TOLERANCES ARE FOR REFERENCE ONLY.

DR BY: HEATH 06-18-1994  
 APPD:  
 THIRD ANGLE PROJECTION  
 EDS DATE 11-11-2011  
 FORMAT REV G  
 CONFIDENTIAL: THIS DRAWING AND ITS INFORMATION ARE THE EXCLUSIVE AND CONFIDENTIAL PROPERTY OF REGAL-BELOIT CORPORATION AND ARE NOT TO BE DISCLOSED, DUPLICATED, DISTRIBUTED OR OTHERWISE USED WITHOUT THE WRITTEN CONSENT OF REGAL-BELOIT CORPORATION. -ALL RIGHTS RESERVED.

REGAL-BELOIT CORPORATION  
 DESCRIPTION: MODEL-RFHP-48FR OUTLINE  
 SIZE C DWG NO 12045-006  
 SCALE NONE SHEET 1

4

3

2

1

REVISION:	ECO	REVISADO POR:	FECHA:	APROBADO POR:	FECHA:
C	0025582	I. ORTIZ	05-01-2012	D. BALDERRAMA	05-01-2012

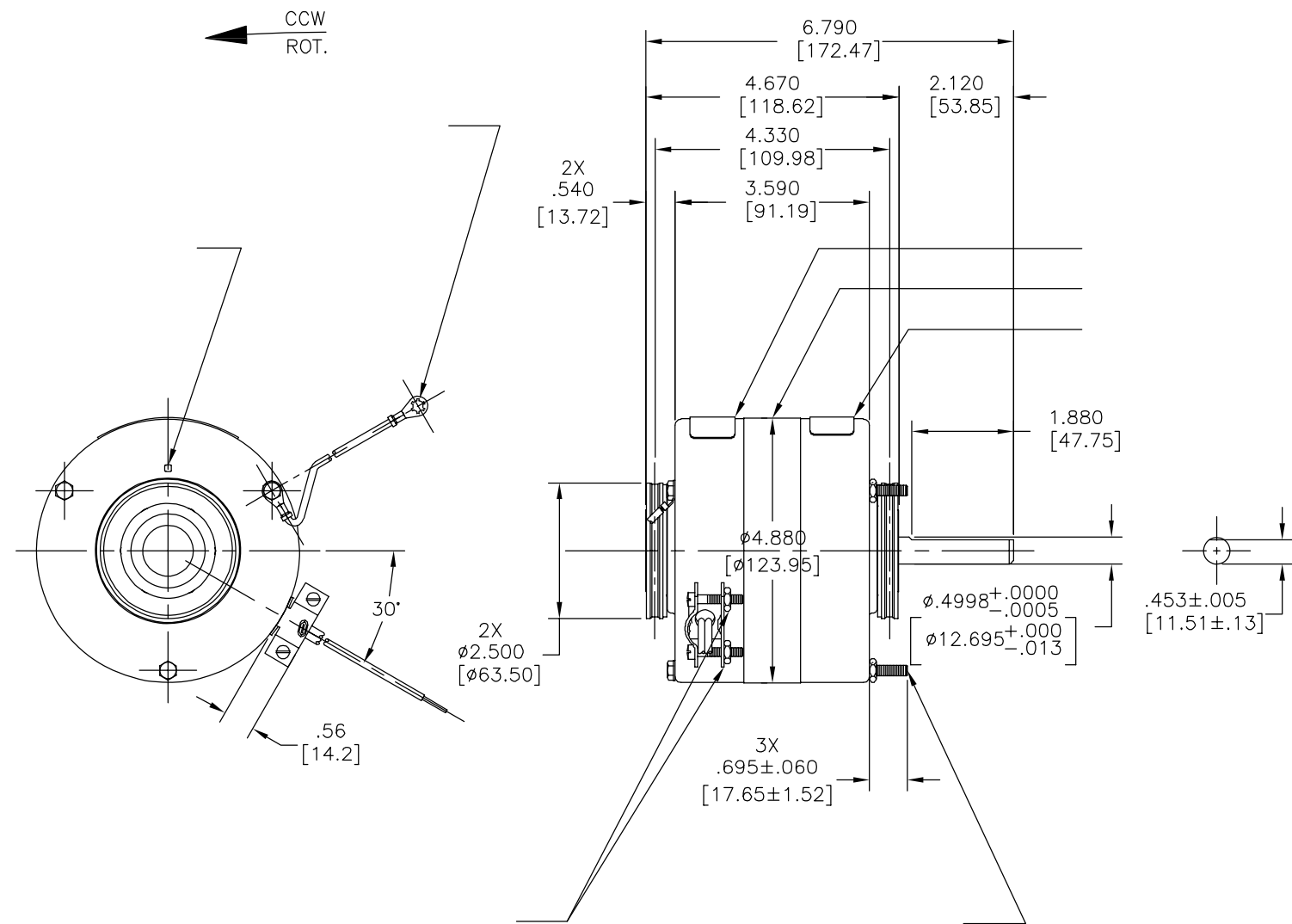

NAMEPLATE DATA:	EXTERNAL CONNECTION DIAGRAM
MODEL NO.: B42A30A01 CUST. P/N: U6430 HP: 1/15 ROT.: CCWLE RPM: 1050 TYPE: FE FRAME: 42Y VOLTS: 115 PH: 1 AMPS: 3.3 HZ: 60 INS: B AMB.: 40°C DUTY: AIR OVER CODE: - CAP.: - ENCL: - UL LOGO CSA LOGO THERMALLY PROTECTED TYPE C	BLK ———   LINE   WHT ———

C31135	8.3 OZ. FT.	94AC108C	E46993	PRGY2	LR43341	260-Ø-0	CSA
--------	-------------	----------	--------	-------	---------	---------	-----

15/17	[381/432]
35/38	[889/965]
35/38	[889/965]

DISTRIBUTION SERVICE

CARACTERISTICAS DE GEOMETRIA Y SIMBOLOS  
 ▮ PLANICIDAD  
 — RECTITUD  
 ∠ ANGULARIDAD  
 ⊥ PERPENDICULARIDAD (A ESCUADRA)  
 // PARALELISMO  
 ○ REDONDEZ (CIRCULARIDAD)  
 ∅ CILINDRICIDAD  
 △ PERFIL DE CUALQUIER SUPERFICIE  
 ∩ PERFIL DE CUALQUIER LINEA  
 ↗ VARIACION  
 ⊕ POSICION REAL  
 ⊙ CONCENTRICIDAD  
 = SIMETRIA  
 ASME Y14.5M 1994

REGAL-BELOIT CORPORATION (RBC) PROVEE ASISTENCIA TECNICA A NUESTROS CLIENTES EN VARIAS AREAS. DESDE QUE RBC NO RECIBE TODOS LOS DATOS EN RELACION AL USO Y A LA APLICACION DEL MOTOR, LA APLICACION ADECUADA DEL MOTOR DEBE SER DETERMINADA POR EL CLIENTE.  
 DIMENSIONES SIN TOLERANCIA SON DE REFERENCIA SOLAMENTE

DIBUJADO POR: HEATH 06-18-1994  
 APROBADO POR:  
 TERCER ANGULO DE PROYECCION  
 CONFIDENCIAL: ESTE DIBUJO Y SU INFORMACION SON PROPIEDAD DE USO EXCLUSIVO Y CONFIDENCIAL DE REGAL-BELOIT CORPORATION. Y NO DEBERAN SER REVELADOS, DUPLICADOS, DISTRIBUIDOS O USARSE DE OTRA MANERA SIN EL CONSENTIMIENTO ESCRITO DE REGAL-BELOIT CORPORATION. -TODOS LOS DERECHOS RESERVADOS.

REGAL-BELOIT CORPORATION  
 DESCRIPCION: MODEL-RFHP-48FR OUTLINE  
 TAMAÑO: C NUMERO DE DIBUJO: 12045-006  
 ESCALA: NONE HOJA: 1

4 3 2 1

版本	ECO	编制	日期	批准	日期
C	0025582	I. ORTIZ	05-01-2012	D. BALDERRAMA	05-01-2012

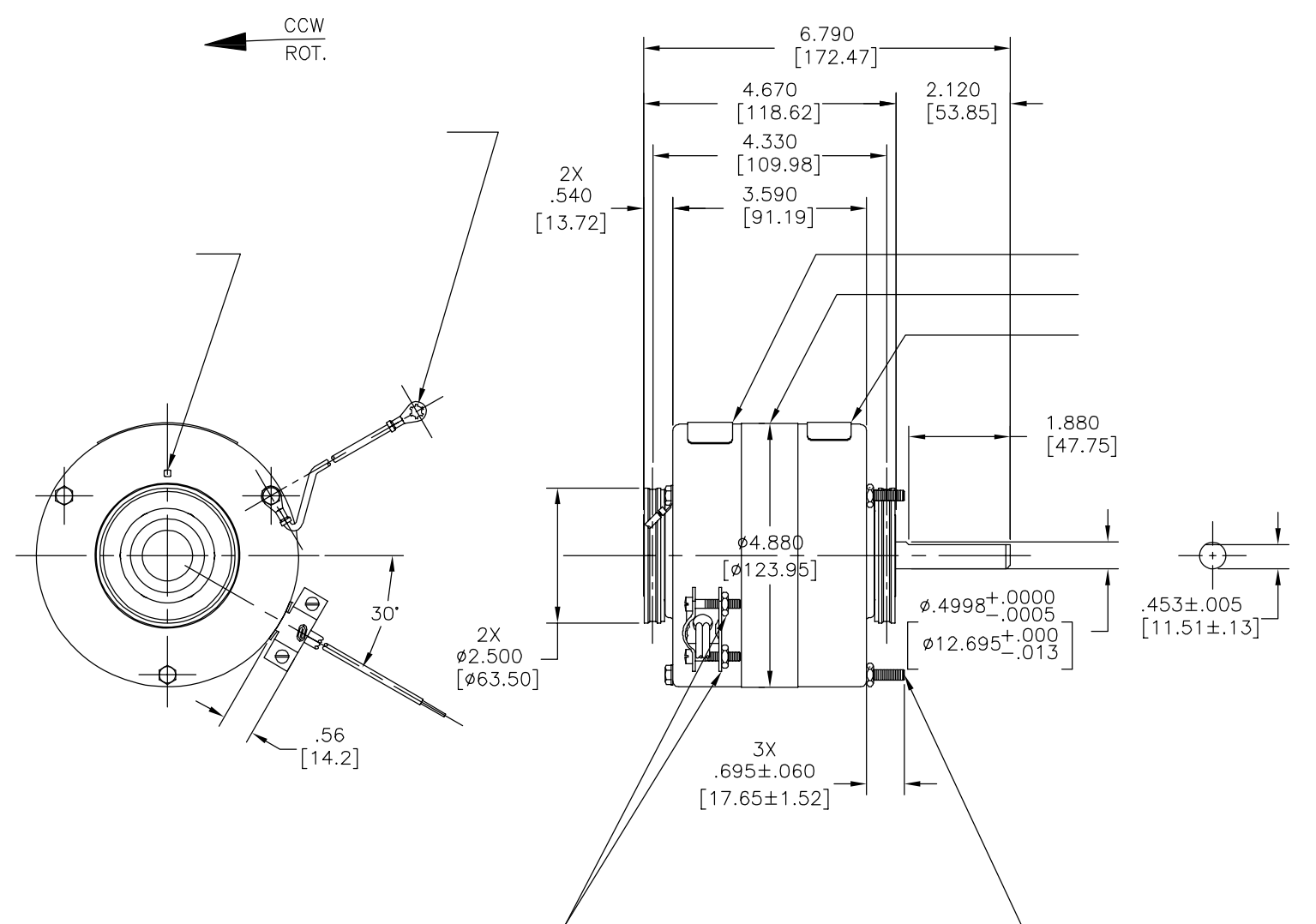

NAMEPLATE DATA:	EXTERNAL CONNECTION DIAGRAM
MODEL NO.: B42A30A01 CUST. P/N: U6430 HP: 1/15 ROT.: CCWLE RPM: 1050 TYPE: FE FRAME: 42Y VOLTS: 115 PH: 1 AMPS: 3.3 HZ: 60 INS: B AMB.: 40°C DUTY: AIR OVER CODE: - CAP.: - ENCL: - UL LOGO CSA LOGO THERMALLY PROTECTED TYPE C	BLK  LINE WHT

C31135	8.3 OZ. FT.	94AC108C	E46993	PRGY2	LR43341	260-Ø-0	CSA
--------	-------------	----------	--------	-------	---------	---------	-----

15/17	[381/432]
35/38	[889/965]
35/38	[889/965]
35/38	[889/965]

DISTRIBUTION SERVICE

形位公差 □ 平面度 - 直线度 < 倾斜度 ⊥ 垂直度 // 平行度 ○ 圆度 ⊙ 圆柱度 △ 面轮廓度 ⊃ 线轮廓度 ↗ 圆跳动 ⊕ 位置度 ⊗ 同轴度 ≡ 对称度	ASME Y14.5M 1994
---	------------------

REGAL-BELOIT CORPORATION (RBC) 在个别领域为客户提供技术支持。鉴于RBC未收到任何涉及电机使用和应用环境的数据，电机的适用性由客户自己决定。

未注公差尺寸仅供参考。

绘图:	HEATH	06-18-1994
批准:		
第三角投影		图纸格式发布日期 11-11-2011 图纸格式版本 G
机密: 本图纸及相关信息所有权归REGAL-BELOIT CORPORATION。未经REGAL-BELOIT CORPORATION书面授权, 不得泄露、复制、传播或作其他用途。—版权所有		

名称	MODEL-RFHP-48FR OUTLINE
图幅	C
图号	12045-006
比例	NONE
页号	1

4 3 2 1

REV	ECO	REV BY	DATE	APPD	DATE
T	ECO-0018824	J.HESS	04-15-2011	J.HESS	04-15-2011

FOR SINGLE SPEED ONLY  
COLOR OF LEADS TO BE OPTIONAL

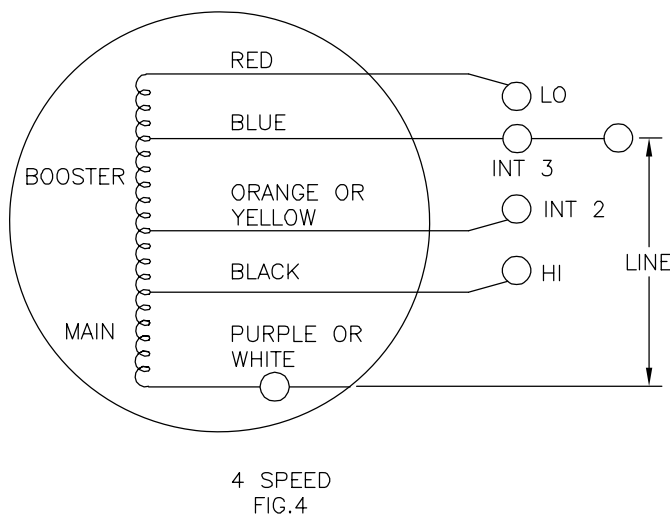
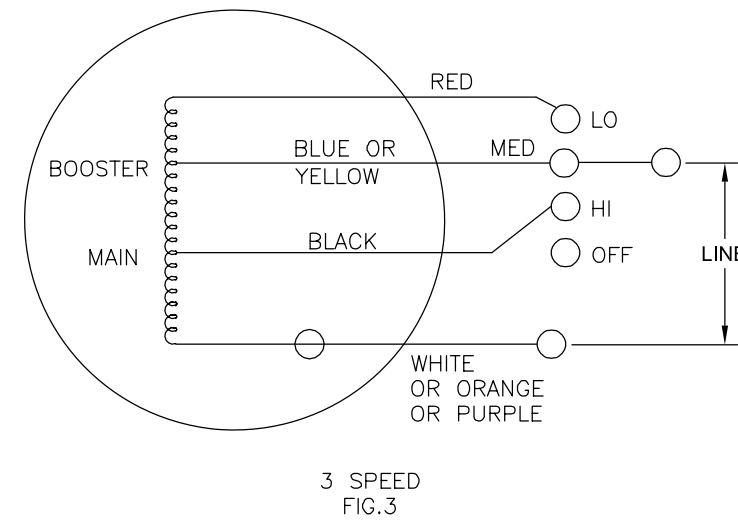
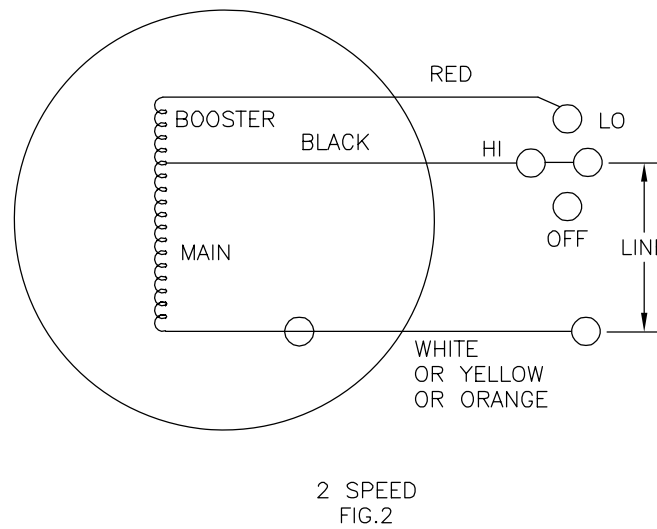
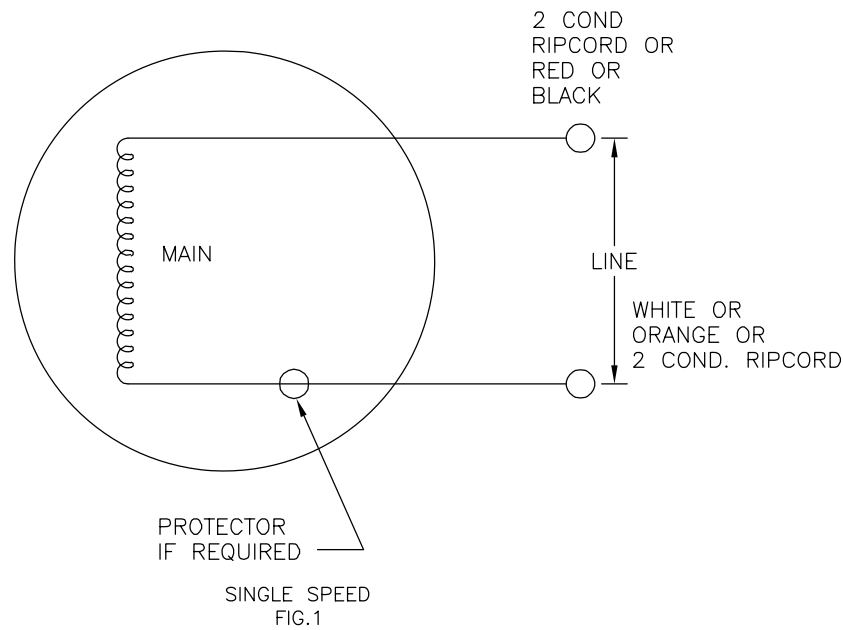

QUALITY CONTROL NOTE:  
TO CHECK THE WINDINGS FOR OPENS VERIFY THE CONTINUITY AS OUTLINED BELOW.  
FIG.1 BETWEEN WHITE AND BLACK OR WHITE & RED LEADS  
FIG.2, 3 & 4, BETWEEN THE WHITE & RED LEADS.

GEOMETRIC CHARACTERISTICS & SYMBOLS

- ▭ FLATNESS
- STRAIGHTNESS
- ∠ ANGULARITY
- ⊥ PERPENDICULARITY (SQUARENESS)
- // PARALLELISM
- ROUNDNESS (CIRCULARITY)
- ⊘ CYLINDRICITY
- △ PROFILE OF ANY SURFACE
- ∩ PROFILE OF ANY LINE
- ↗ RUNOUT
- ⊕ TRUE POSITION
- ⊙ CONCENTRICITY
- ≡ SYMMETRY

UNLESS OTHERWISE SPECIFIED  
DIM. TOLERANCES ARE AS FOLLOWS:

INCH	±.1	±.02	±.005	±.0005
mm	±0.5	±0.13	±0.013	

ANG. ±.50 DEG  
REMOVE BURRS & BREAK SHARP EDGES:  
INCH .003-.015 mm 0.1-0.4  
CORNER FILLETS TO:  
INCH .020 mm 0.5  
MACHINE SURFACES:  
INCH 125 mm 3.2  
METRIC DIMS. SHOWN IN [BRACKETS]

DR BY:	KLINE	10-24-1966
APPD:	RDS	10-27-1966
THIRD ANGLE PROJECTION		EDS DATE 02-22-2008 FORMAT REV F
CONFIDENTIAL: THIS DRAWING AND ITS INFORMATION ARE THE EXCLUSIVE AND CONFIDENTIAL PROPERTY OF A.O. SMITH CORP. AND ARE NOT TO BE DISCLOSED, DUPLICATED, DISTRIBUTED OR OTHERWISE USED WITHOUT THE WRITTEN CONSENT OF A.O. SMITH CORP. -ALL RIGHTS RESERVED. ASME Y14.5M 1994		

<b>ACSmith</b> Innovation has a name.		<b>ELECTRICAL PRODUCTS COMPANY</b> A DIVISION OF A. O. SMITH CORPORATION	
DESCRIPTION CONN DIAGRAM-EXTERNAL			
SIZE C	DWG NO 261B865F01	SHEET 1	
SCALE NONE			

REVISION:	ECO	REVISADO POR:	FECHA:	APROBADO POR:	FECHA:
T	ECO-0018824	J.HESS	04-15-2011	J.HESS	04-15-2011

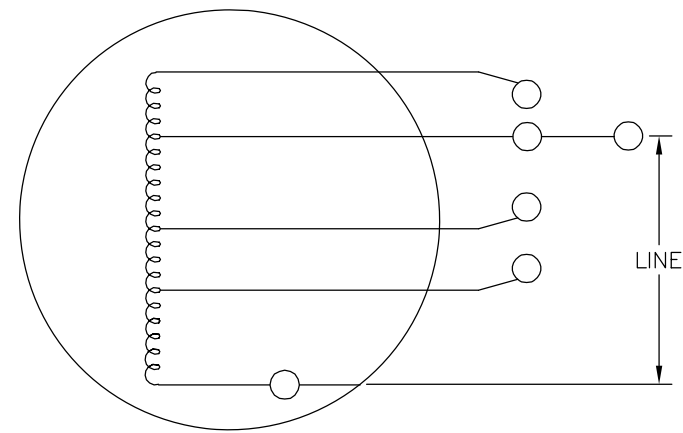
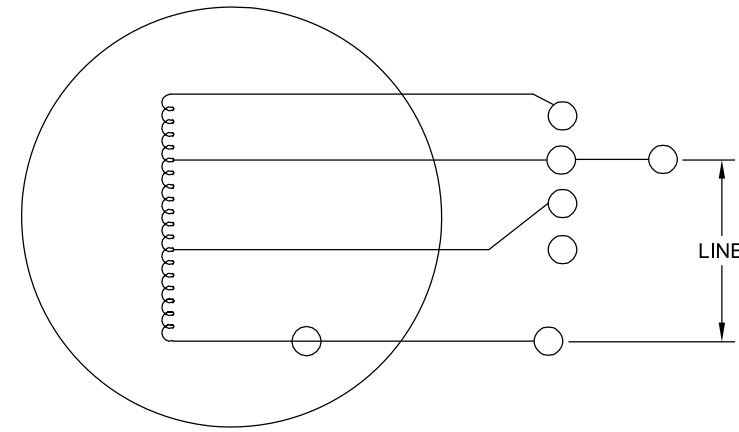
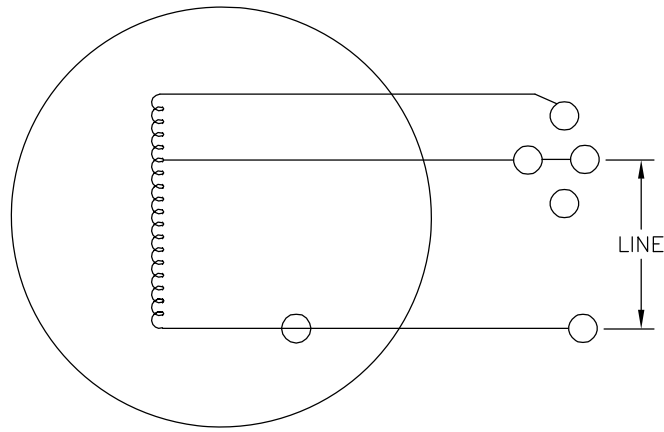
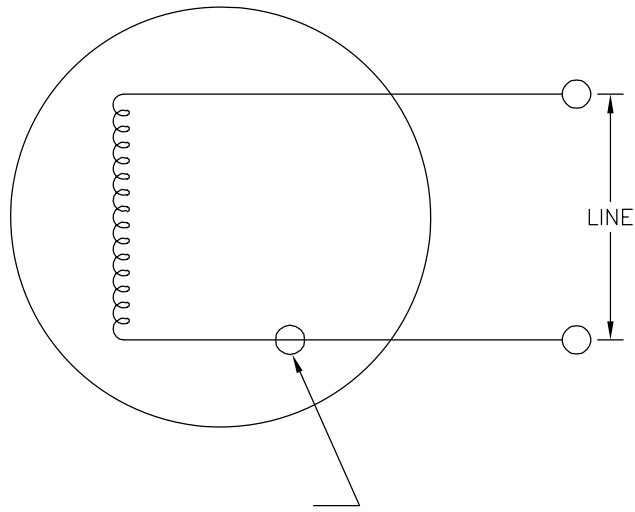

CARACTERISTICAS DE GEOMETRIA Y SIMBOLOS

- ▭ PLANICIDAD
- RECTITUD
- ∠ ANGULARIDAD
- ⊥ PERPENDICULARIDAD (A ESCUADRA)
- // PARALELISMO
- REDONDEZ (CIRCULARIDAD)
- ∅ CILINDRICIDAD
- △ PERFIL DE CUALQUIER SUPERFICIE
- ∩ PERFIL DE CUALQUIER LINEA
- ↑ VARIACION
- ⊕ POSICION REAL
- ◎ CONCENTRICIDAD
- = SIMETRIA

A MENOS QUE SE ESPECIFIQUE DE OTRA MANERA, LAS TOLERANCIAS DE LAS DIMS; SON LAS SIGUIENTES:

PULG	±.1	±.02	±.005	±.0005
mm	±0.5	±0.13	±0.013	

ANG. ± 50 GRADOS  
ELIMINAR REBABAS Y ORILLAS FILOSAS DEL BORDE.

PULG	.003-.015	mm	0.1-0.4
------	-----------	----	---------

FILETEAR ESQUINA: PULG .020 mm 0.5  
MAQUINAR SUPERFICIES  
PULG 125 mm .32

DIMS METRICAS MOSTRADAS [PARENTESIS]

DIBUJADO POR: KLINE	10-24-1966
APROBADO POR: RDS	10-27-1966
TERCER ANGULO DE PROYECCION	 FECHA EDS: 02-22-2008 REV. FORMATO: F
CONFIDENCIAL: ESTE DIBUJO Y SU INFORMACION SON PROPIEDAD DE USO EXCLUSIVO Y CONFIDENCIAL DE A.O.SMITH CORP. Y NO DEBERAN SER REVELADOS, DUPLICADOS, DISTRIBUIDOS O USARSE DE OTRA MANERA SIN EL CONSENTIMIENTO ESCRITO DE A.O. SMITH CORP. -TODOS LOS DERECHOS RESERVADOS.ASME Y14.5M 1994	

 <b>ELECTRICAL PRODUCTS COMPANY</b> <small>A DIVISION OF A. O. SMITH CORPORATION</small>	
DESCRIPCION: CONN DIAGRAM-EXTERNAL	
TAMAÑO: C	NUMERO DE DIBUJO: 261B865F01
ESCALA:NONE	HOJA: 1

4

3

2

1

版本	ECO	编制	日期	批准	日期
T	ECO-0018824	J.HESS	04-15-2011	J.HESS	04-15-2011

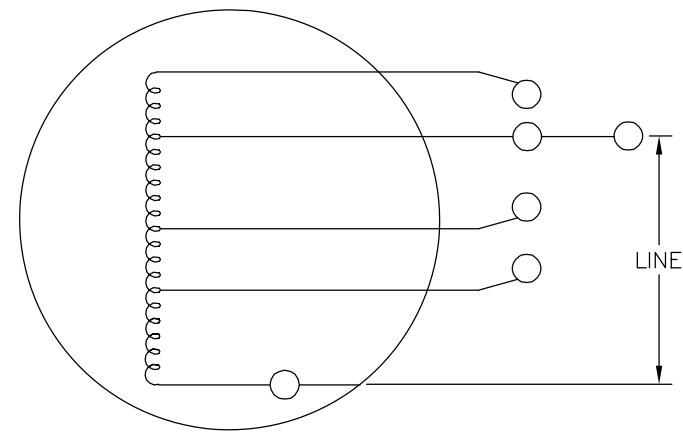
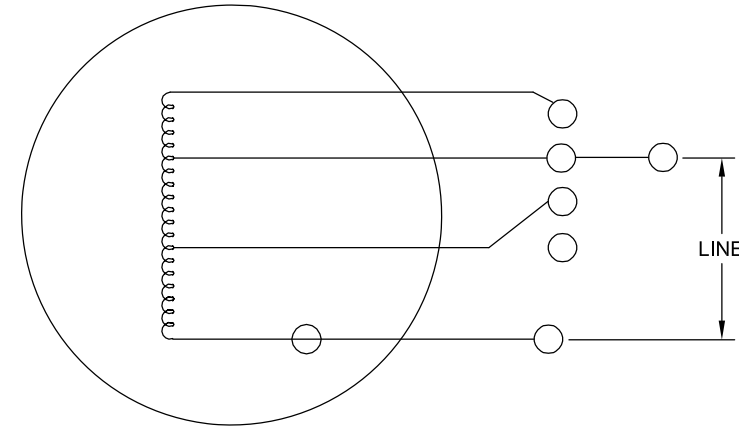
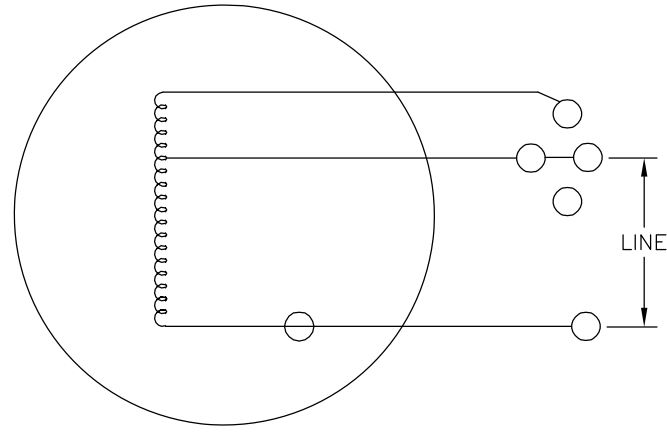
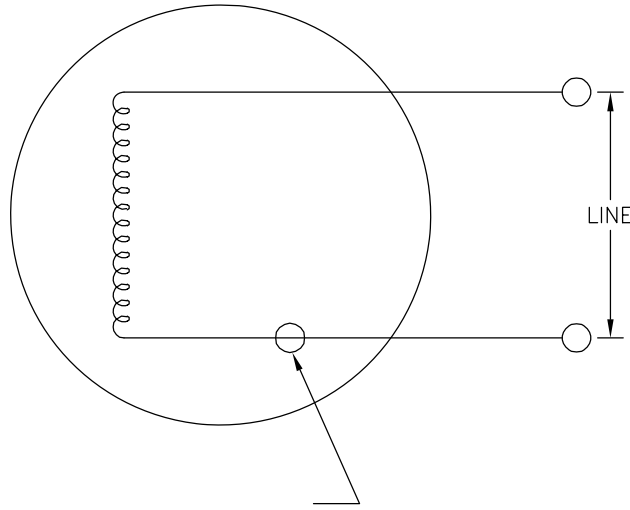

形位公差
□ 平面度
— 直线度
∠ 倾斜度
⊥ 垂直度
// 平行度
○ 圆度
⊘ 圆柱度
∩ 内圆角
△ 面轮廓度
∩ 线轮廓度
↗ 圆跳动
⊕ 位置度
⊙ 同轴度
≡ 对称度

除另有注明 尺寸公差如下:
英寸 X XX XXX XXXX
毫米 ±0.1 ±0.02 ±0.005 ±0.0005
毫米 ±0.5 ±0.13 ±0.013
角度 ±.50 度
清理毛刺和尖棱
英寸 .003-.015 毫米 0.1-0.4
内圆角
英寸 .020 毫米 0.5
表面粗糙度
英制 125 米制 3.2
米制尺寸显示在 [ ]

绘图:	KLINE	10-24-1966
批准:	RDS	10-27-1966
第三角投影		图纸格式发布日期 02-22-2008 图纸格式版本 F
机密: 本图纸及相关信息所有权归A. O. SMITH公司所有。 未经A. O. SMITH公司书面授权, 不得泄露、复制、传播或作 其他用途。—版权所有		
ASME Y14.5M 1994		

<b>ACSmith</b> Innovation has a name.		<b>ELECTRICAL PRODUCTS COMPANY</b> A DIVISION OF A. O. SMITH CORPORATION	
名称 CONN DIAGRAM-EXTERNAL			
图幅	C	图号	261B865F01
比例	NONE	页号	1

4

3

2

1