

PRODUCT INFORMATION PACKET



Model No: H697V1
Catalog No: H697V1
1.5 HP Condenser Fans HVAC/R Motor, 3 phase, 1200 RPM, 200-230/460 V, 56Y Frame, TEAO
Condenser Fans Motors



Regal and Century are trademarks of Regal Rexnord Corporation or one of its affiliated companies.
©2021 Regal Rexnord Corporation, All Rights Reserved. MC017097E





Nameplate Specifications

Output HP	1.5 Hp	Output KW	1.1 kW
Frequency	60 Hz	Voltage	200-230/460 V
Current	5.4-5.6/2.8 A	Speed	1140 rpm
Service Factor	1.15	Phase	3
Efficiency	81.5 %	Duty	Continuous
Insulation Class	B	Frame	56Y
Enclosure	Totally Enclosed Air Over	Thermal Protection	Thermally Protected
Ambient Temperature	70 °C	UL	Recognized
CSA	Y	CE	N
Number of Speeds	1		

Technical Specifications

Electrical Type	Three Phase	Starting Method	Across The Line
Poles	6	Rotation	Reversible
Mounting	Round	Drive End Bearing	Ball
Opp Drive End Bearing	Ball	Frame Material	Rolled Steel
Shaft Type	Keyed	Overall Length	18.26 in
Frame Length	9.25 in	Shaft Diameter	0.625 in
Shaft Extension	6.19 in		
Connection Drawing	DD10174-001	Outline Drawing	OL56100263-001

This is an uncontrolled document once printed or downloaded and is subject to change without notice. Date Created:10/07/2021

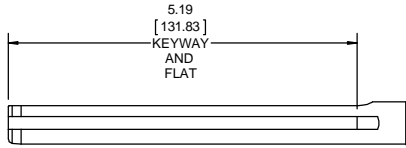

SECTION B-B

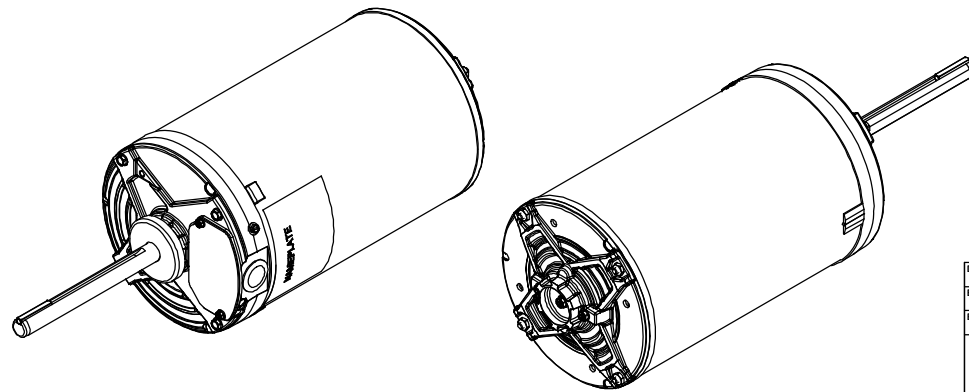
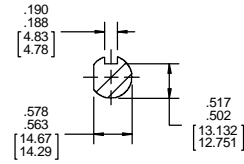
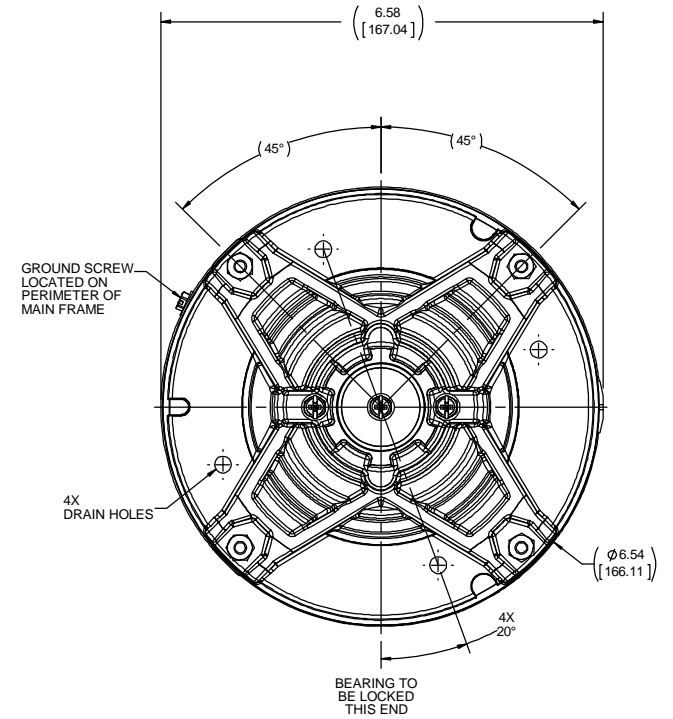
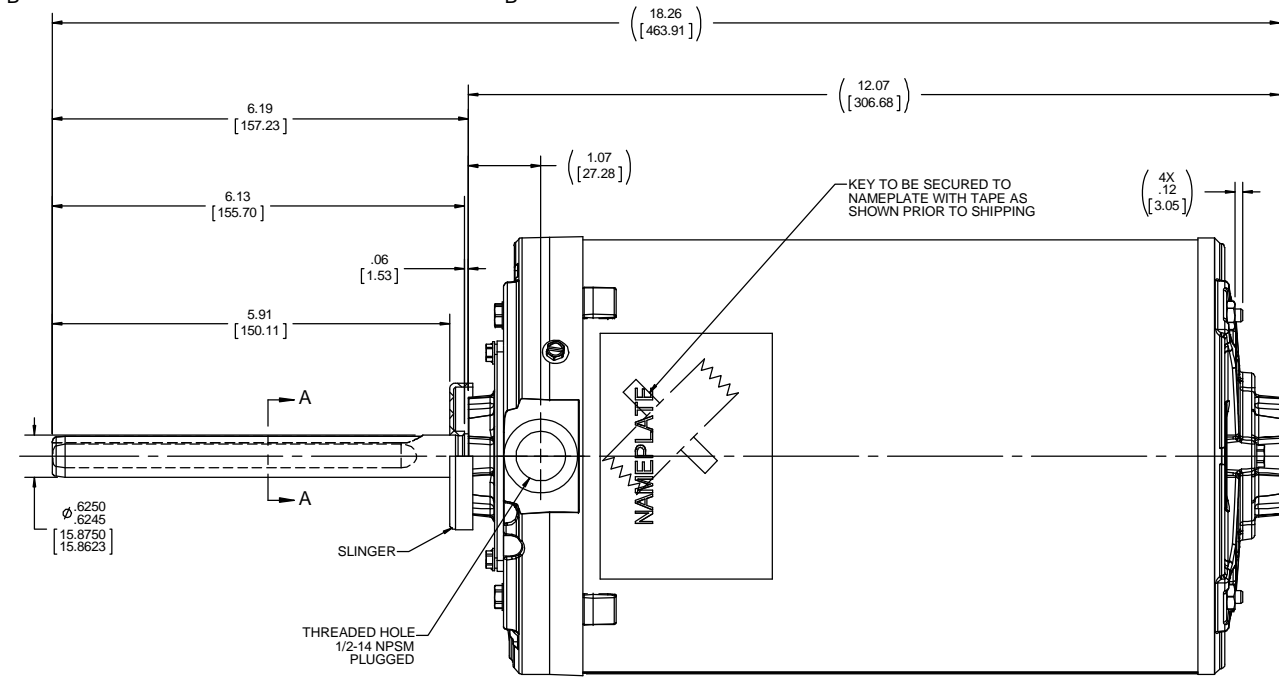

DRAWING REVISION A		REVISION BY	DATE	TOLERANCES UNLESS OTHERWISE SPECIFIED:		DRAWN BY E. VILLA	Regal Beloit America, Inc.
ECO-0126161	APPROVED BY	DATE	DEC.	INCH	mm	ANGLE	
ECO DESCRIPTION NMR RELEASE				.X	±0.1	[±2.5]	APPROVED BY M. RAMIREZ
<small>COPYRIGHT REGAL BELOIT AMERICA, INC. ALL RIGHTS RESERVED. PROPRIETARY AND CONFIDENTIAL INFORMATION. THIS DOCUMENT IS THE PROPERTY OF REGAL BELOIT AMERICA, INC. FORMERLY AND CONTAINING OWNERS PROPRIETARY INFORMATION. ANY PERSON, CORPORATION OR OTHER FIRM RECEIVING IT IS DEEMED BY RECEIVING IT, TO AGREE THAT IT, AND/OR ANY PART OF IT, SHALL NOT BE DISCLOSED TO ANY PERSON, CORPORATION OR OTHER ENTITY, DUPLICATED, AND/OR USED, EXCEPT AS EXPRESSLY APPROVED IN WRITING IN ADVANCE BY OWNER. THIS DOCUMENT SHALL BE RETURNED TO OWNER UPON REQUEST. IT MAY BE SUBJECT TO CERTAIN RESTRICTIONS UNDER APPLICABLE EXPORT CONTROL LAWS AND REGULATIONS.</small>				.XXX	±0.005	[±0.127]	DATE 07-04-2017
				.XXXX	±0.0005	[±0.0127]	REFERENCE
				REMOVE BURRS & BREAK SHARP EDGES: .003/.015 [Ø76/.381] X 45° CORNER FILLETS: R. 02 [51]		THIRD ANGLE PROJECTION	SIZE C
				MACHINED SURFACES: 125 / 3.2 INCH / mmv		DRAWING NUMBER OL56100263-001	PROCESS/FINISH
				mm SHOWN IN (BRACKETS)		SHEET 1 OF 1	

LOW VOLTAGE

HIGH VOLTAGE

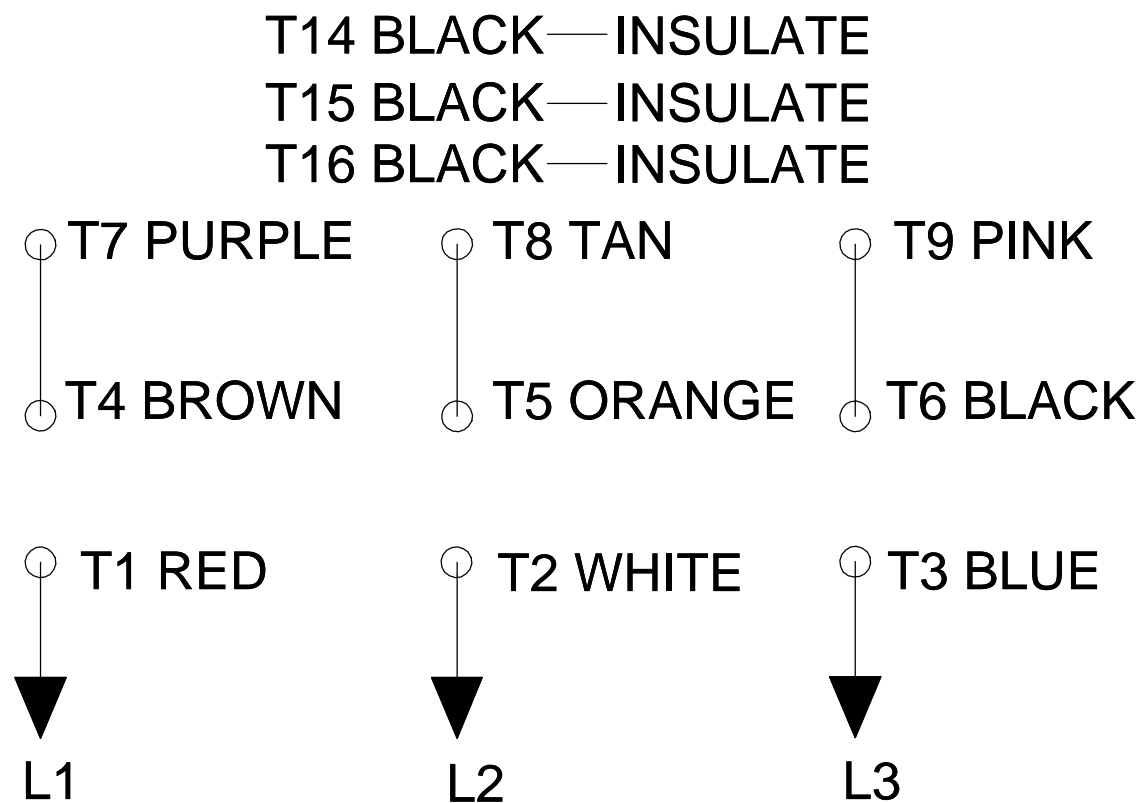
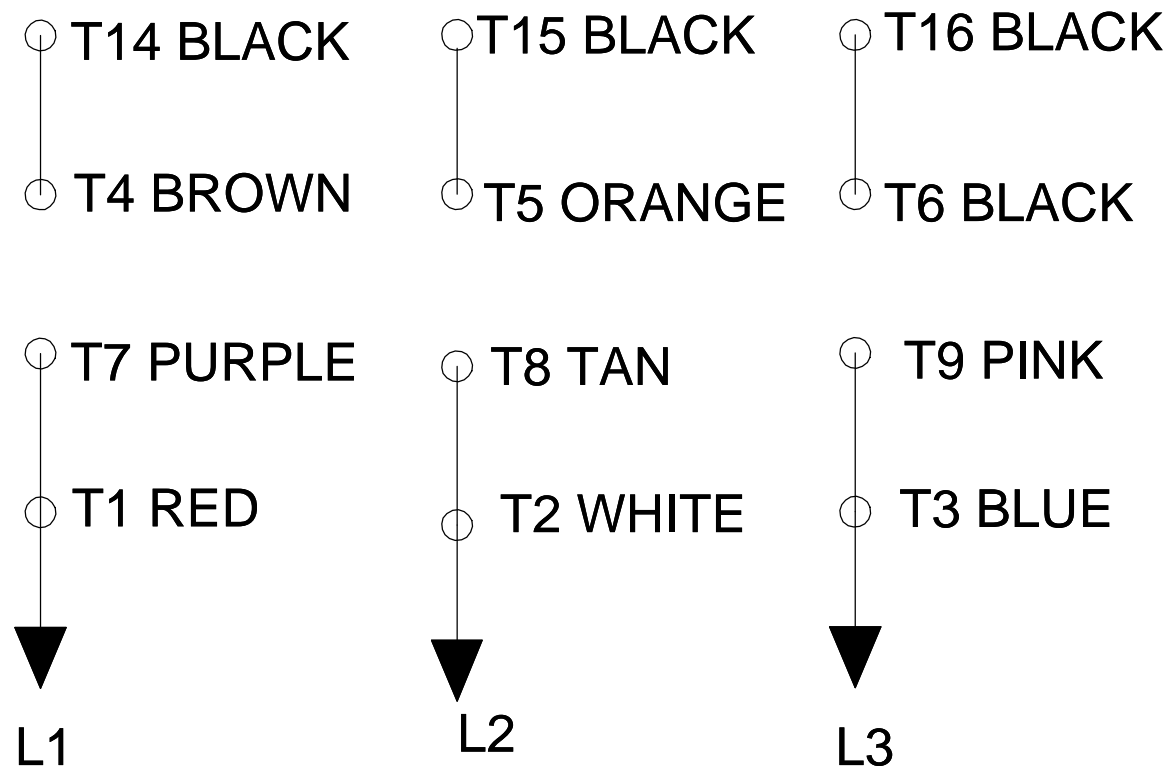

DD10174-001

ROTATION CCW-LE TO REVERSE INTERCHANGE ANY TWO LINE LEADS

PLATE: 41365

SLOT: 22

DRAWING REVISION B	REVISION BY G. RODRIGUEZ	DATE 08-04-2018	TOLERANCES UNLESS OTHERWISE SPECIFIED: DEC. INCH mm ANGLE .X ±0.1 [±2.5] ±0.5° .XX ±0.01 [±0.25] .XXX ±0.005 [±0.127] .XXXX ±0.0005 [±0.0127]	DRAWN BY G. RODRIGUEZ	Regal Beloit America, Inc.
ECO ECO-0150209	APPROVED BY J. A. MORENO	DATE 08-04-2018		DATE 08-03-2018	
ECO DESCRIPTION CHANGE CONNECTION			REMOVE BURRS & BREAK SHARP EDGES: .003/.015 [.076/.381] X 45° CORNER FILLETS: R.02 [.51] MACHINED SURFACES: 125/3.2 INCH/mm	APPROVED BY J.A. MORENO	DESCRIPTION CONN DIAGRAM-NAMEPLATE
COPYRIGHT REGAL BELOIT AMERICA, INC. ALL RIGHTS RESERVED. PROPRIETARY AND CONFIDENTIAL INFORMATION - THIS DOCUMENT IS THE PROPERTY OF REGAL BELOIT AMERICA, INC. ("OWNER") AND CONTAINS OWNER'S PROPRIETARY INFORMATION. ANY PERSON, CORPORATION OR OTHER FIRM RECEIVING IT IS DEEMED, BY RECEIVING IT, TO AGREE THAT IT, AND/OR ANY PART OF IT, SHALL NOT BE DISCLOSED TO ANY PERSON, CORPORATION OR OTHER ENTITY, DUPLICATED, AND/OR USED, EXCEPT AS EXPRESSLY APPROVED IN WRITING IN ADVANCE BY OWNER. THIS DOCUMENT SHALL BE RETURNED TO OWNER UPON REQUEST. IT MAY BE SUBJECT TO CERTAIN RESTRICTIONS UNDER APPLICABLE EXPORT CONTROL LAWS AND REGULATIONS.			DATE 08-03-2018	REFERENCE	MATERIAL
			THIRD ANGLE PROJECTION	SIZE B	DRAWING NUMBER DD10174-001
					PROCESS/FINISH
					SHEET 1 OF 1

CENTURY

TYPICAL PERFORMANCE CURVE for AC MOTOR

Customer WW Grainger

Curve at

460

Volts

HP 1.5

PHASE 3

Model No H697V1

60

HZ

VOLTS 200-230/460

1.5

HP

Catalog No H697V1

HZ 60

RPM 1140

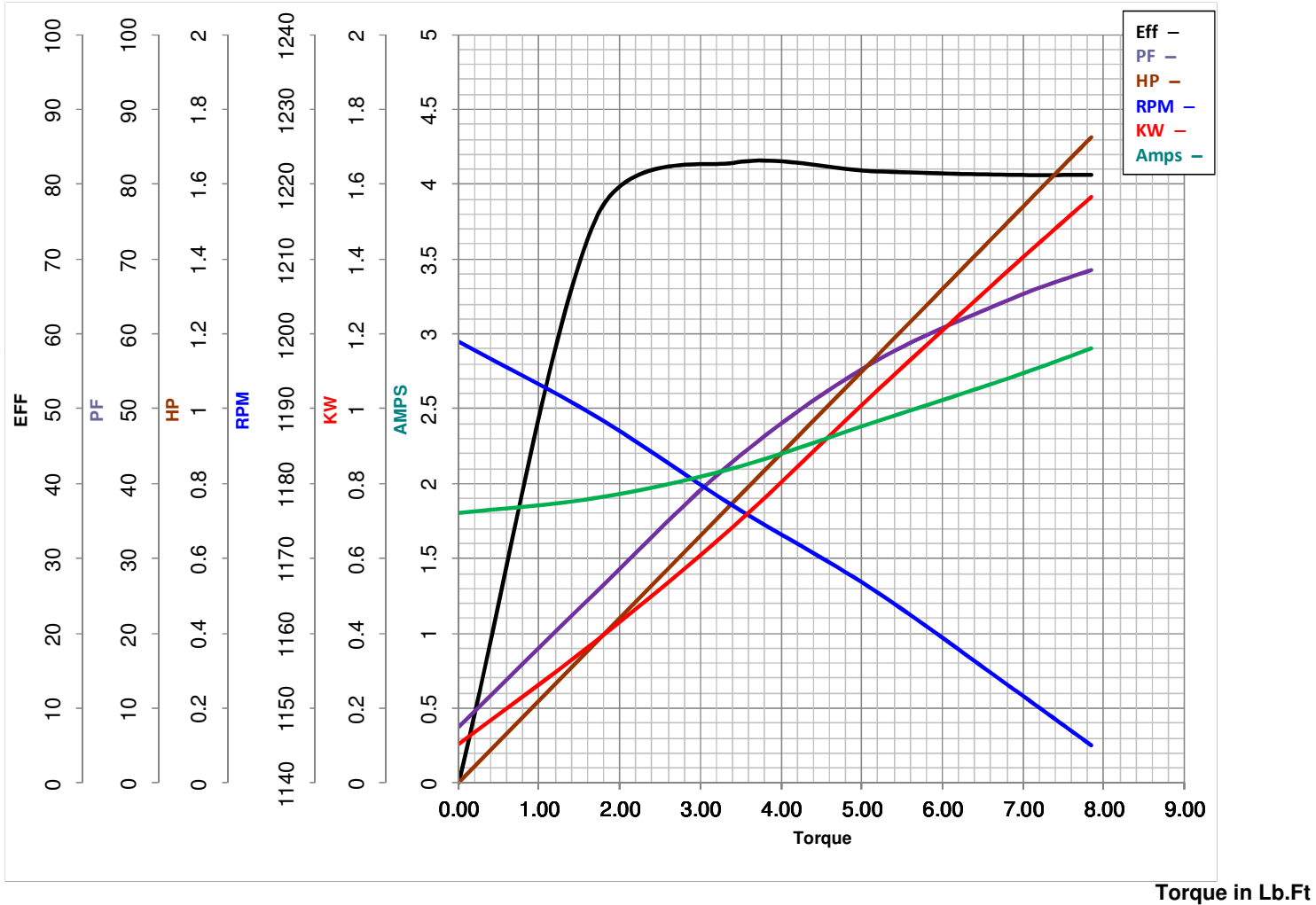

FL TORQUE 6.813 Lb.Ft
 BD TORQUE 21.2 Lb.Ft
 LR TORQUE 16.19 Lb.Ft

FL AMPS 5.4-5.6/2.8
 PU TORQUE 16.2 Lb.Ft
 LR AMPS 13.43

WINDING NT56627-3

Prepared By BHARGAVI

Date 8/17/2018