

PRODUCT INFORMATION PACKET



Model No: H506

Catalog No: H506

1.0 HP General Purpose Pump Motor, 3 phase, 3600 RPM, 208-230/460 V, 56J Frame, ODP
General Purpose Pump Motors



Regal and Century are trademarks of Regal Rexnord Corporation or one of its affiliated companies.
©2021 Regal Rexnord Corporation, All Rights Reserved. MC017097E





Nameplate Specifications

Output HP	1.0 Hp	Output KW	0.75 kW
Frequency	60/50 Hz	Voltage	208-230/460 V
Current	SF 4.3-4.0/2.0 A	Speed	3450/2850 rpm
Service Factor	1.4	Phase	3
Duty	Continuous	Insulation Class	B
Frame	L56J	Enclosure	Drip Proof
Thermal Protection	None	Ambient Temperature	40 °C
UL	Recognized	CSA	Y
CE	N	Number of Speeds	1

Technical Specifications

Electrical Type	Polyphase, Induction Type, Single Or Dual Voltage	Starting Method	Across The Line
Poles	2	Rotation	Reversible Clockwise
Mounting	Round	Drive End Bearing	Ball
Opp Drive End Bearing	Ball	Frame Material	Rolled Steel
Shaft Type	Threaded	Overall Length	11.85 in
Frame Length	6.25 in	Shaft Diameter	0.625 in
Shaft Extension	2.60 in		
Connection Drawing	18304024.PCX	Outline Drawing	12687-004

This is an uncontrolled document once printed or downloaded and is subject to change without notice. Date Created:10/07/2021

REV	ECO	REV BY	DATE	APPD	DATE
B	ECO-0023680	J. COX	12-09-2011	.	.

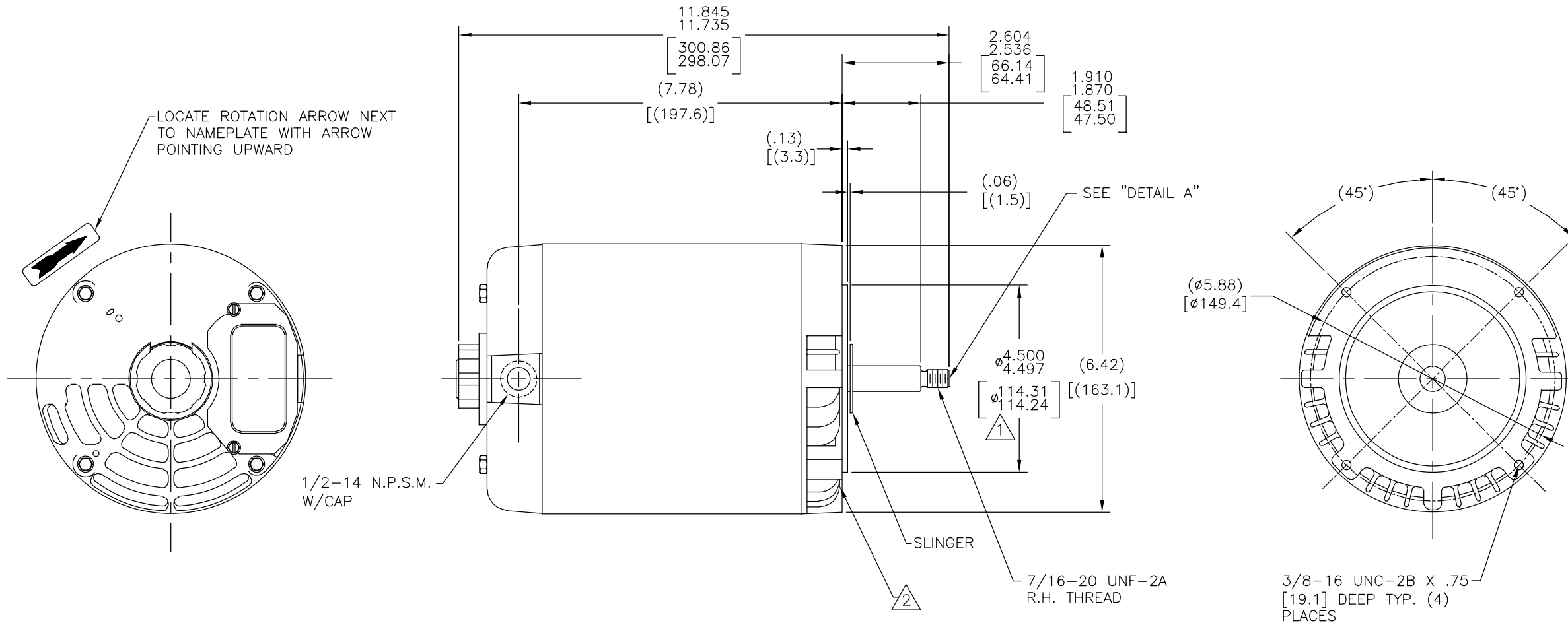

NAMEPLATE DATA	EXTERNAL CONNECTION DIAGRAM	PERFORMANCE CURVE NO.	APPROVED SAMPLE OR REF. MODEL				
MODEL: 187143 CUST. P/N: H506 HP: 1.0 SF: 1.40 ROT: RCW RPM: 3450/2850 TYPE: SC CODE: L FRAME: L 56 J VOLTS: 208-230/460 AMPS: SF 4.3-4.0/2.0 MAX AMPS: PH: 3 HZ: 60/50 INS: B AMB: 40°C DUTY: CONT	<table border="0"> <tr> <td style="vertical-align: middle;">183040-24</td> <td> LOW VOLTAGE 4-BROWN 5-ORANGE 6-BLACK 1-RED 7-PURPLE 2-WHITE 8-GRAY 3-BLUE 9-PINK LINE 1 LINE 2 LINE 3 </td> <td> TO REVERSE, INTER-CHANGE ANY TWO LINE LEADS. </td> <td> HIGH VOLTAGE 4-BROWN 7-PURPLE 5-ORANGE 8-GRAY 6-BLACK 9-PINK 1-RED 2-WHITE 3-BLUE LINE 1 LINE 2 LINE 3 </td> </tr> </table>	183040-24	LOW VOLTAGE 4-BROWN 5-ORANGE 6-BLACK 1-RED 7-PURPLE 2-WHITE 8-GRAY 3-BLUE 9-PINK LINE 1 LINE 2 LINE 3	TO REVERSE, INTER-CHANGE ANY TWO LINE LEADS.	HIGH VOLTAGE 4-BROWN 7-PURPLE 5-ORANGE 8-GRAY 6-BLACK 9-PINK 1-RED 2-WHITE 3-BLUE LINE 1 LINE 2 LINE 3	18098621	
183040-24	LOW VOLTAGE 4-BROWN 5-ORANGE 6-BLACK 1-RED 7-PURPLE 2-WHITE 8-GRAY 3-BLUE 9-PINK LINE 1 LINE 2 LINE 3	TO REVERSE, INTER-CHANGE ANY TWO LINE LEADS.	HIGH VOLTAGE 4-BROWN 7-PURPLE 5-ORANGE 8-GRAY 6-BLACK 9-PINK 1-RED 2-WHITE 3-BLUE LINE 1 LINE 2 LINE 3				
		UL COMPONENT	CSA				
		FILE#	CCN#				
		E44549	PRGY2				
		FILE#	CLASS#				
		LR4642	4211-01				
		ENCLOSURE: ODP	CUSTOMER: DISTRIBUTION				

NOTES:

1. PILOT DIAMETER IS CONCENTRIC WITH SHAFT CENTERLINE WITHIN .004 T.I.R.

2. FACE OF MOUNTING FLANGE IS PERPENDICULAR TO SHAFT CENTERLINE WITHIN .004 T.I.R.

3. SHAFT RUNOUT NOT TO EXCEED .002 T.I.R.

4. FOR THREADED SHAFT EXT. MATING PARTS SHOULD BE RELIEVED ONE THREAD TO CLEAR FILLET.

5. FOR THREADER SHAFT EXT. ECCENTRICITY OF THREADED PORTION OF SHAFT IS HELD WITHIN .004 TOTAL GAGE READING WITH THE INDICATOR ON O.D. OF GROUND RING AS SHOWN. THE GAGE BEING STATIONARY WITH RESPECT TO THE ROTOR.

6. END PLAY NOT TO EXCEED .010 MEASURED WITH NO THRUST

7. ALL DIMENSIONS SHOWN IN PARENTHESIS ARE REFERENCE DIMENSIONS.

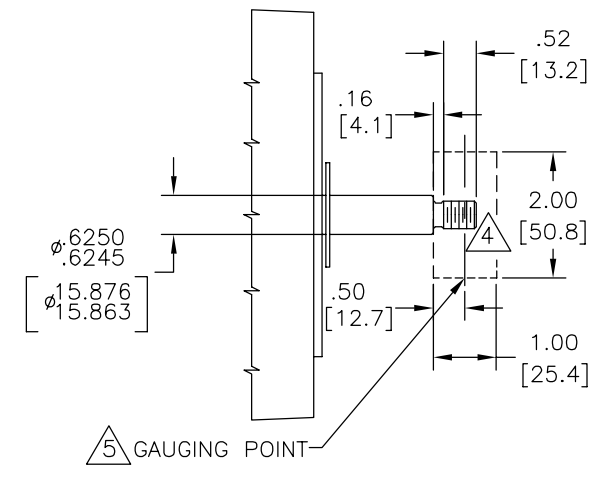

DETAIL A
SCALE = 1:2

GEOMETRIC CHARACTERISTICS & SYMBOLS ▭ FLATNESS — STRAIGHTNESS < ANGLARITY ⊥ PERPENDICULARITY (SQUARENESS) // PARALLELISM ○ ROUNDNESS (CIRCULARITY) ∅ CYLINDRICITY ∩ PROFILE OF ANY SURFACE ∩ PROFILE OF ANY LINE ↗ RUNOUT ⊕ TRUE POSITION ⊙ CONCENTRICITY ≡ SYMMETRY ASME Y14.5M 1994	UNLESS OTHERWISE SPECIFIED DIM. TOLERANCES ARE AS FOLLOWS: INCH X XX XXX XXXX mm ±0.5 ±0.13 ±0.013 ANG. ±.50 DEG REMOVE BURRS & BREAK SHARP EDGES: INCH .003-.015 mm 0.1-0.4 CORNER FILLETS TO: INCH .020 mm 0.5 MACHINE SURFACES: INCH 125 mm 3.2 METRIC DIMS. SHOWN IN [BRACKETS]	DR BY: KHR	09-08-2005	DESCRIPTION MODEL-CFHP-56FR OUTLINE SIZE C DWG NO 12687-004 SCALE NONE SHEET 1	
		APPD:			EDS DATE 11-11-2011
		THIRD ANGLE PROJECTION			FORMAT REV G
		CONFIDENTIAL: THIS DRAWING AND ITS INFORMATION ARE THE EXCLUSIVE AND CONFIDENTIAL PROPERTY OF REGAL-BELOIT CORPORATION AND ARE NOT TO BE DISCLOSED, DUPLICATED, DISTRIBUTED OR OTHERWISE USED WITHOUT THE WRITTEN CONSENT OF REGAL-BELOIT CORPORATION. -ALL RIGHTS RESERVED.			

4

3

2

1

REVISION:	ECO	REVISADO POR:	FECHA:	APROBADO POR:	FECHA:
B	ECO-0023680	J. COX	12-09-2011	.	.

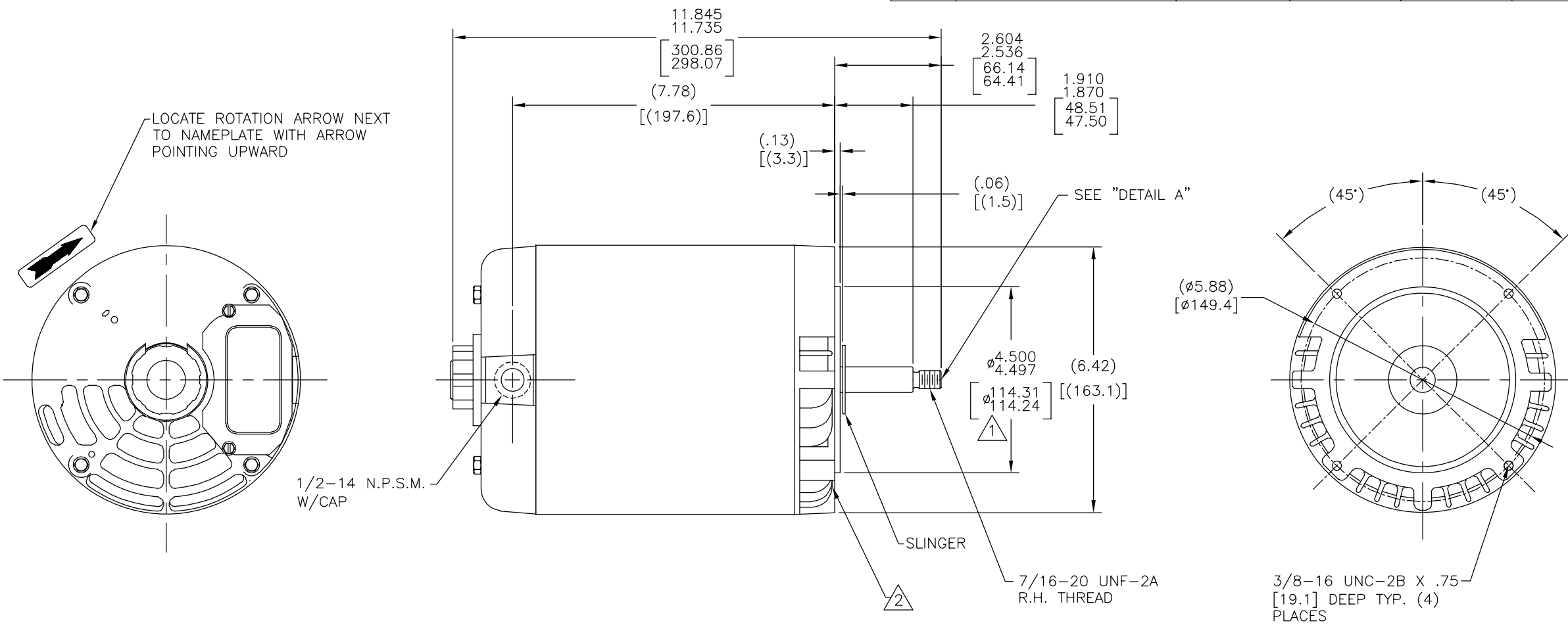

NAMEPLATE DATA
MODEL: 187143 CUST. P/N: H506 HP: 1.0 SF: 1.40 ROT: RCW RPM: 3450/2850 TYPE: SC CODE: L FRAME: L 56 J VOLTS: 208-230/460 AMPS: SF 4.3-4.0/2.0 MAX AMPS: PH: 3 HZ: 60/50 INS: B AMB: 40°C DUTY: CONT

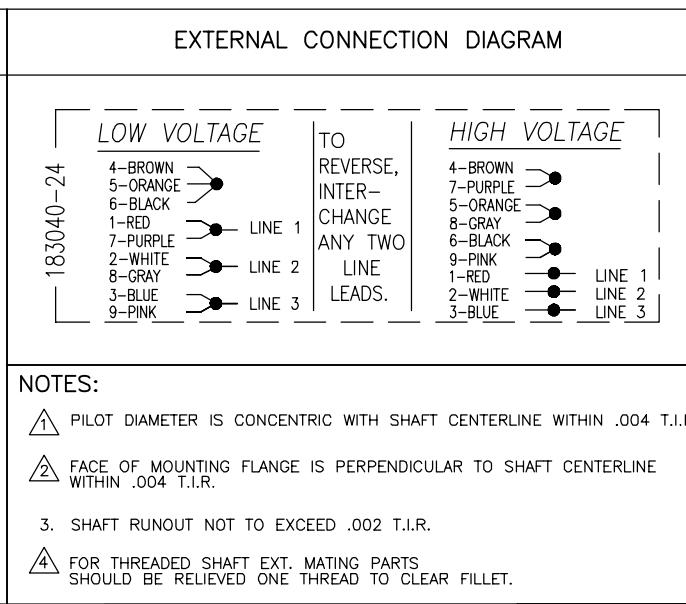

PERFORMANCE CURVE NO.		APPROVED SAMPLE OR REF. MODEL	
18098621			
UL COMPONENT		CSA	
FILE#	CCN#	FILE#	CLASS#
E44549	PRGY2	LR4642	4211-01
ENCLOSURE: ODP		CUSTOMER: DISTRIBUTION	

5. FOR THREADER SHAFT EXT. ECCENTRICITY OF THREADED PORTION OF SHAFT IS HELD WITHIN .004 TOTAL GAGE READING WITH THE INDICATOR ON O.D. OF GROUND RING AS SHOWN. THE GAGE BEING STATIONARY WITH RESPECT TO THE ROTOR.

6. END PLAY NOT TO EXCEED .010 MEASURED WITH NO THRUST

7. ALL DIMENSIONS SHOWN IN PARENTHESIS ARE REFERENCE DIMENSIONS.

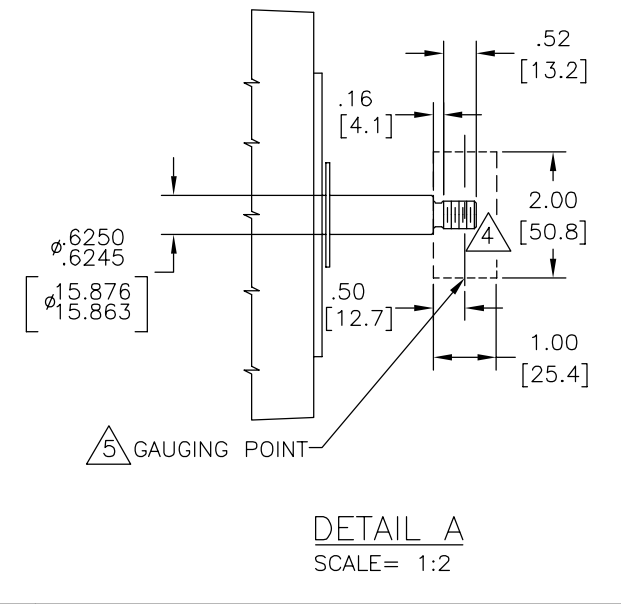

CARACTERISTICAS DE GEOMETRIA Y SIMBOLOS
□ PLANICIDAD - RECTITUD < ANGULARIDAD ⊥ PERPENDICULARIDAD (A ESCUADRA) // PARALELISMO ○ REDONDEZ (CIRCULARIDAD) ∅ CILINDRICIDAD △ PERFIL DE CUALQUIER SUPERFICIE ▲ PERFIL DE CUALQUIER LINEA ↗ VARIACION ⊕ POSICION REAL ⊙ CONCENTRICIDAD = SIMETRIA

ASME Y14.5M 1994

A MENOS QUE SE ESPECIFIQUE DE OTRA MANERA, LAS TOLERANCIAS DE LAS DIMS; SON LAS SIGUIENTES:
PULG ±.1 ±.02 ±.005 ±.0005 mm ±0.5 ±0.13 ±0.013 ANG. ±.50 GRADOS ELIMINAR REBABAS Y ORILLAS FILOSAS DEL BORDE. PULG .003-.015 mm 0.1-0.4 FILETEAR ESQUINA: PULG .020 mm 0.5 MAQUINAR SUPERFICIES PULG 125 mm 3.2

DIMS METRICAS MOSTRADAS [PARENTESIS]

DIBUJADO POR: KHR	09-08-2005
APROBADO POR:	
TERCER ANGULO DE PROYECCION	FECHA EDS: 11-11-2011 REV. FORMATO: G
CONFIDENCIAL: ESTE DIBUJO Y SU INFORMACION SON PROPIEDAD DE USO EXCLUSIVO Y CONFIDENCIAL DE REGAL-BELOIT CORPORATION. Y NO DEBERAN SER REVELADOS, DUPLICADOS, DISTRIBUIDOS O USARSE DE OTRA MANERA SIN EL CONSENTIMIENTO ESCRITO DE REGAL-BELOIT CORPORATION. -TODOS LOS DERECHOS RESERVADOS.	

DESCRIPCION: MODEL-CFHP-56FR OUTLINE	
TAMAÑO: C	NUMERO DE DIBUJO: 12687-004
ESCALA: NONE	HOJA: 1

4

3

2

1

4

3

2

1

版本	ECO	编制	日期	批准	日期
B	ECO-0023680	J. COX	12-09-2011	.	.

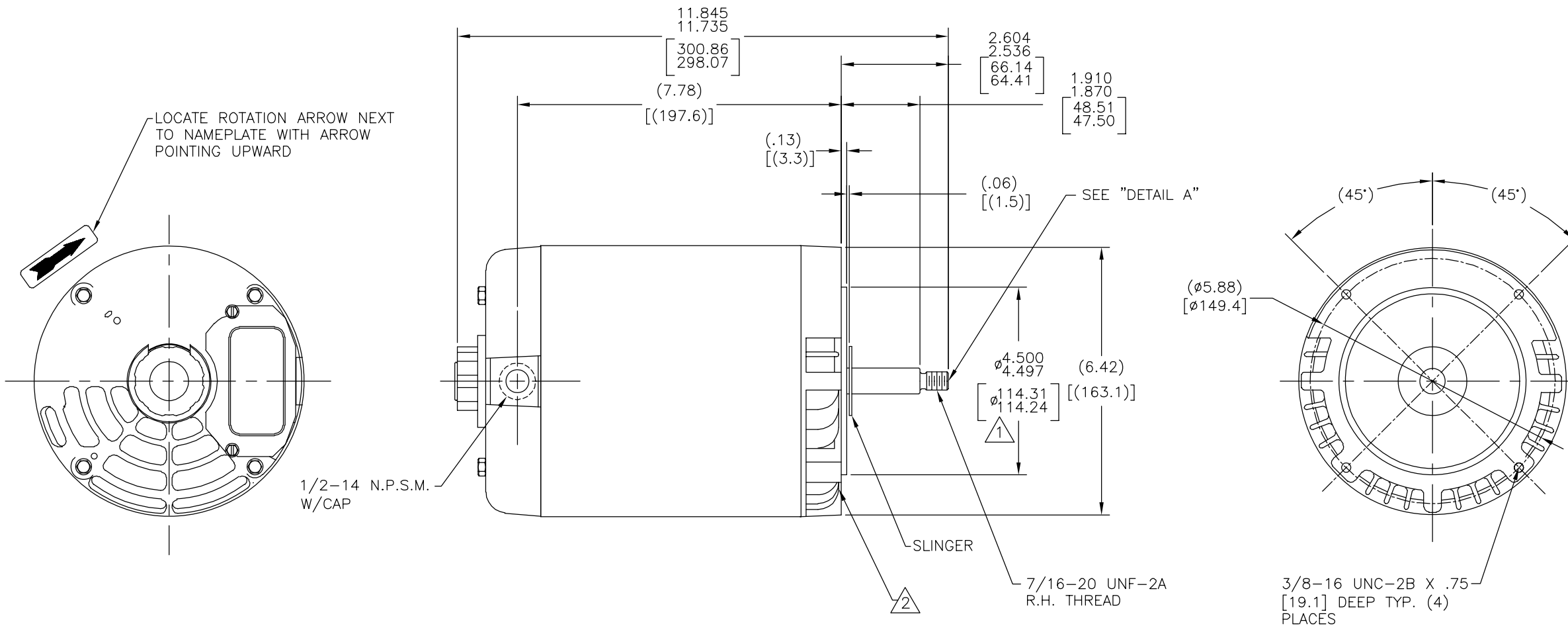

NAMEPLATE DATA	EXTERNAL CONNECTION DIAGRAM	PERFORMANCE CURVE NO.	APPROVED SAMPLE OR REF. MODEL									
MODEL: 187143 CUST. P/N: H506 HP: 1.0 SF: 1.40 ROT: RCW RPM: 3450/2850 TYPE: SC CODE: L FRAME: L 56 J VOLTS: 208-230/460 AMPS: SF 4.3-4.0/2.0 MAX AMPS: PH: 3 HZ: 60/50 INS: B AMB: 40°C DUTY: CONT	<table border="1"> <tr> <th>LOW VOLTAGE</th> <th>TO REVERSE, INTER-CHANGE ANY TWO LINE LEADS.</th> <th>HIGH VOLTAGE</th> </tr> <tr> <td> 4-BROWN 5-ORANGE 6-BLACK 1-RED 7-PURPLE 2-WHITE 8-GRAY 3-BLUE 9-PINK </td> <td> LINE 1 LINE 2 LINE 3 </td> <td> 4-BROWN 7-PURPLE 5-ORANGE 8-GRAY 6-BLACK 9-PINK 1-RED 2-WHITE 3-BLUE </td> </tr> <tr> <td></td> <td></td> <td> LINE 1 LINE 2 LINE 3 </td> </tr> </table>	LOW VOLTAGE	TO REVERSE, INTER-CHANGE ANY TWO LINE LEADS.	HIGH VOLTAGE	4-BROWN 5-ORANGE 6-BLACK 1-RED 7-PURPLE 2-WHITE 8-GRAY 3-BLUE 9-PINK	LINE 1 LINE 2 LINE 3	4-BROWN 7-PURPLE 5-ORANGE 8-GRAY 6-BLACK 9-PINK 1-RED 2-WHITE 3-BLUE			LINE 1 LINE 2 LINE 3	18098621	
LOW VOLTAGE	TO REVERSE, INTER-CHANGE ANY TWO LINE LEADS.	HIGH VOLTAGE										
4-BROWN 5-ORANGE 6-BLACK 1-RED 7-PURPLE 2-WHITE 8-GRAY 3-BLUE 9-PINK	LINE 1 LINE 2 LINE 3	4-BROWN 7-PURPLE 5-ORANGE 8-GRAY 6-BLACK 9-PINK 1-RED 2-WHITE 3-BLUE										
		LINE 1 LINE 2 LINE 3										
		UL COMPONENT	CSA									
		FILE#	CCN#									
		E44549	PRGY2									
		FILE#	CLASS#									
		LR4642	4211-01									
		ENCLOSURE: ODP	CUSTOMER: DISTRIBUTION									

NOTES:

1. PILOT DIAMETER IS CONCENTRIC WITH SHAFT CENTERLINE WITHIN .004 T.I.R.

2. FACE OF MOUNTING FLANGE IS PERPENDICULAR TO SHAFT CENTERLINE WITHIN .004 T.I.R.

3. SHAFT RUNOUT NOT TO EXCEED .002 T.I.R.

4. FOR THREADED SHAFT EXT. MATING PARTS SHOULD BE RELIEVED ONE THREAD TO CLEAR FILLET.

5. FOR THREADER SHAFT EXT. ECCENTRICITY OF THREADED PORTION OF SHAFT IS HELD WITHIN .004 TOTAL GAGE READING WITH THE INDICATOR ON O.D. OF GROUND RING AS SHOWN. THE GAGE BEING STATIONARY WITH RESPECT TO THE ROTOR.

6. END PLAY NOT TO EXCEED .010 MEASURED WITH NO THRUST

7. ALL DIMENSIONS SHOWN IN PARENTHESIS ARE REFERENCE DIMENSIONS.

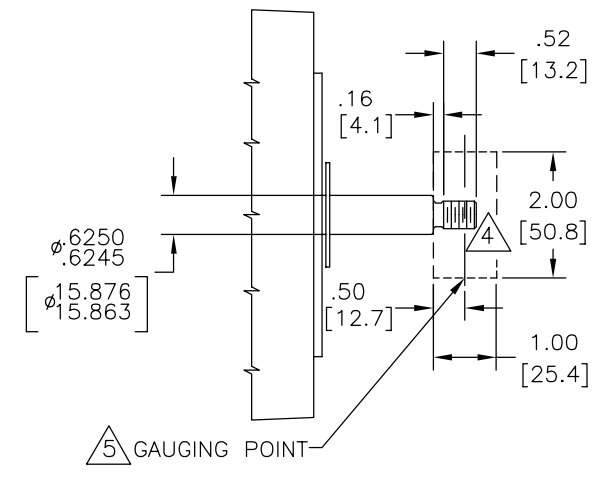

DETAIL A
SCALE = 1:2

形位公差 □ 平面度 — 直线度 < 倾斜度 ⊥ 垂直度 // 平行度 ○ 圆度 ⊙ 圆柱度 ⊖ 面轮廓度 △ 线轮廓度 ↗ 圆跳动 ⊕ 位置度 ⊗ 同轴度 ≡ 对称度	除另有注明 尺寸公差如下: 英寸 X XX XXX XXXX 毫米 ±0.1 ±0.02 ±0.005 ±0.0005 毫米 ±0.5 ±0.13 ±0.013 角度 ±.50 度 清理毛刺和尖棱 英寸 .003-.015 毫米 0.1-0.4 内圆角 英寸 .020 毫米 0.5 表面粗糙度 英制 125 米制 3.2
---	--

ASME Y14.5M 1994 米制尺寸显示在 []

绘图:	KHR	09-08-2005
批准:		
第三角投影		图纸格式发布日期 11-11-2011 图纸格式版本 G
机密: 本图纸及相关信息所有权归REGAL-BELOIT CORPORATION 未经REGAL-BELOIT CORPORATION书面授权, 不得泄露、 复制、传播或作其他用途。—版权所有		

名称	MODEL-CFHP-56FR OUTLINE
图幅	C
图号	12687-004
比例	NONE
页号	1

4

3

2

1