

PRODUCT INFORMATION PACKET



Model No: FML1036
Catalog No: FML1036

Fan Coil & Air Conditioner Motor, 1/3 HP, 1 Ph, 60 Hz, 115 V, 1075 RPM, 3 Speed, 48 Frame, OAO



Regal and Century are trademarks of Regal Rexnord Corporation or one of its affiliated companies.
©2022 Regal Rexnord Corporation, All Rights Reserved. MC017097E





Nameplate Specifications

Output HP	1/3 Hp	Output KW	0.25 kW
Frequency	60 Hz	Voltage	115 V
Current	6.3 A	Speed	1075 rpm
Service Factor	1	Phase	1
Duty	Air Over	Insulation Class	B
Frame	48Y	Enclosure	Open Air Over
Thermal Protection	Automatic	Ambient Temperature	50 °C
UL	Recognized	CSA	Y
CE	N	Number of Speeds	3

Technical Specifications

Electrical Type	Permanent Split Capacitor	Starting Method	Across The Line
Poles	6	Rotation	Reversible
Mounting	Flexible Arms	Motor Orientation	Horizontal
Drive End Bearing	Ball	Opp Drive End Bearing	Ball
Frame Material	Rolled Steel	Shaft Type	Flat
Overall Length	10.36 in	Frame Length	3.75 in
Shaft Diameter	0.500 in	Shaft Extension	6 in
Outline Drawing	FML1036-S01		

This is an uncontrolled document once printed or downloaded and is subject to change without notice. Date Created:11/28/2022

GENERAL INFORMATION:

SHAFT RUNOUT: .001[.03] T.I.R. PER INCH LENGTH OF EXTENSION.

BEARINGS: BALL

MOUNTING POSITION: HORIZONTAL

ELECTRICAL DATA:

OVERLOAD PROTECTOR: AUTOMATIC RESET (T.I. 7AM 036)

LEADS: NO. 18 GA., .03[.8] THK., 125°C INSUL.

GROUND LEAD: NO. 18 GA., .03[.8] THK., (GREEN) INSUL.

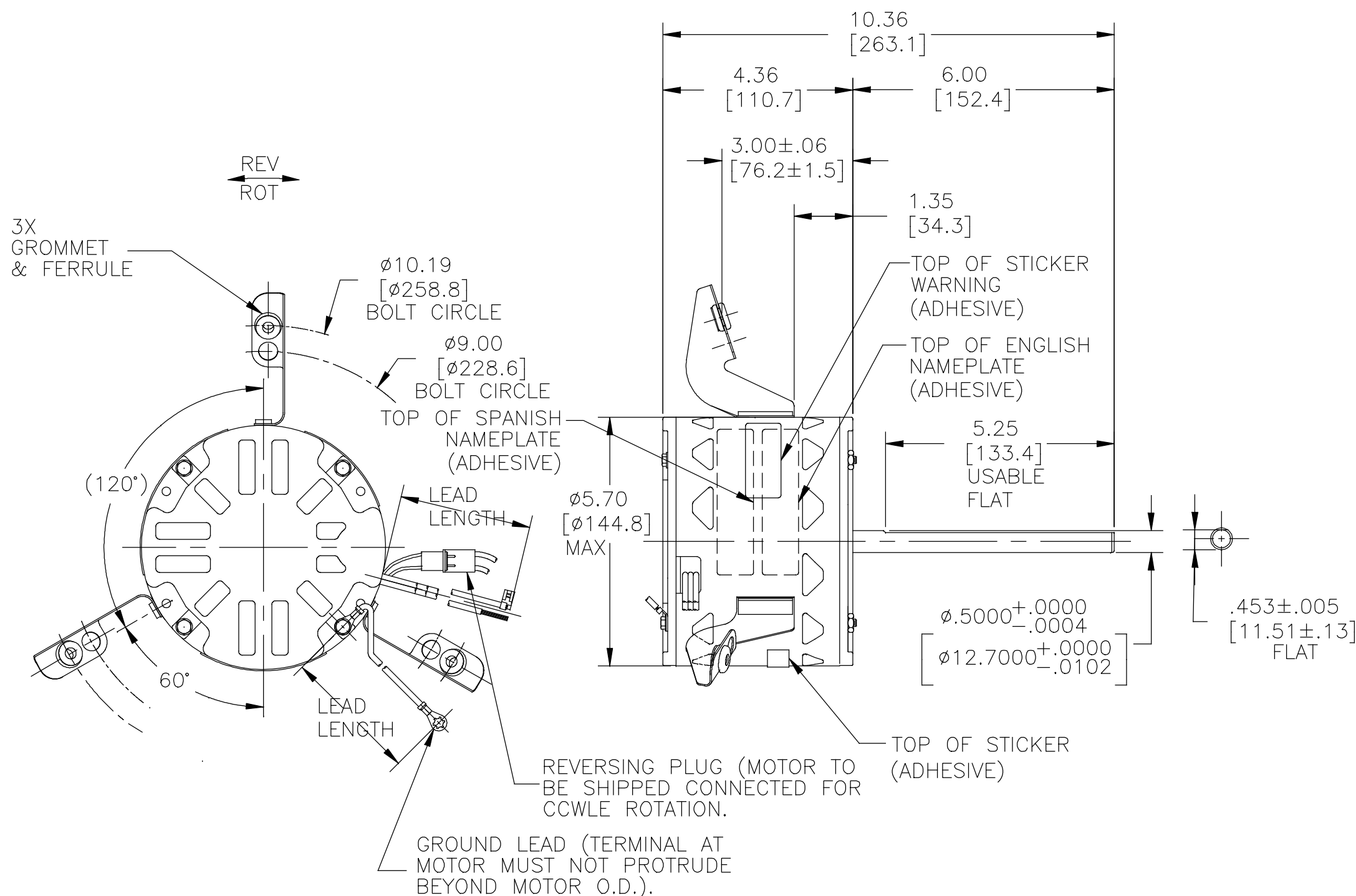

NOTES:
 1. THE SYMBOL OF CTQ: ▲ (NO CTQ ON THIS DRAWING)
 2. MEET THE REQUIREMENT OF RoHS AND REACH: SEE EPO00014_5.1

REGAL-BELOIT CORPORATION (RBC) PROVIDES TECHNICAL ASSISTANCE TO OUR CUSTOMERS IN SEVERAL AREAS. SINCE RBC DOES NOT RECEIVE ALL DATA CONCERNING THE USE AND APPLICATION OF THE MOTOR, THE SUITABILITY OF THE MOTOR FOR THE APPLICATION MUST BE DETERMINED BY THE CUSTOMER.
 DIMENSIONS WITHOUT TOLERANCES ARE FOR REFERENCE ONLY.

ENCLOSURE	
END FRAME - LE	OPEN
MAIN FRAME - LE	OPEN
END FRAME - OLE	OPEN
MAIN FRAME - OLE	OPEN

CUSTOMER	DISTRIBUTION SERVICE
----------	----------------------

LEAD DATA		
COLOR	LENGTH	TERMINAL OR STRIP LENGTH
RED	26/28 [660/711]	.50 [12.7] SKIN
BLUE	26/28 [660/711]	.50 [12.7] SKIN
BLACK	26/28 [660/711]	.50 [12.7] SKIN
YELLOW	26/28 [660/711]	.50 [12.7] SKIN
BROWN	26/28 [660/711]	.25 [6.35] FLAG
BROWN/WHITE	26/28 [660/711]	.25 [6.35] FLAG
BLACK/WHITE	3/5 [76/127]	REVERSING PLUG
GREEN (GRD)	12/13 [304/330]	#10 EYELET

NAMEPLATE DATA:	EXTERNAL CONNECTION DIAGRAM
MODEL NO.: F48N83A01 CUST. P/N: FML1036 HP: 1/3 ROT.: REVERSIBLE RPM: 1075/3 SPD. TYPE: UF FRAME: 48Y VOLTS: 115 PH: 1 AMPS: 6.3 HZ: 60 INS.: B AMB.: 50° C DUTY: AIR OVER CAP.: 10 MFD/370V ENCL: OPEN UL LOGO CSA LOGO THERMALLY PROTECTED	

PERFORMANCE CURVE NO.	TORQUE @ 1075 RPM (25°C)	APPROVED SAMPLE	UL COMPONENT		CSA	
			FILE #	CCN #	FILE #	CLASS #
C31881	37.1 OZ. FT.	---	E46412	PRGY2	LR43341	4211-01

DRAWING REVISION D	REVISION BY HANNA.ZOU	DATE 10-28-2019
ECO	APPROVED BY KEYUN.GONG	DATE 10-28-2019
ECO-0175712		
ECO DESCRIPTION CHANGE SLEEVE TO BALL, REMOVE END PLAY		
<small>COPYRIGHT REGAL-BELOIT AMERICA, INC. ALL RIGHTS RESERVED. PROPRIETARY AND CONFIDENTIAL INFORMATION - THIS DOCUMENT IS THE PROPERTY OF REGAL-BELOIT AMERICA, INC. (OWNER) AND CONTAINS OWNER'S PROPRIETARY INFORMATION. ANY PERSON, CORPORATION OR OTHER FIRM RECEIVING IT IS DEEMED, BY RECEIVING IT, TO AGREE THAT IT, AND/OR ANY PART OF IT, SHALL NOT BE DISCLOSED TO ANY PERSON, CORPORATION OR OTHER ENTITY, DUPLICATED, AND/OR USED, EXCEPT AS EXPRESSLY APPROVED IN WRITING IN ADVANCE BY OWNER. THIS DOCUMENT SHALL BE RETURNED TO OWNER UPON REQUEST. IT MAY BE SUBJECT TO CERTAIN RESTRICTIONS UNDER APPLICABLE EXPORT CONTROL LAWS AND REGULATIONS.</small>		

DRAWN BY: T. SHARP	
DATE: 10-03-1995	
APPROVED BY: D. CORBIN	
DATE: 10-05-1995	
PROCESS/FINISH	
THIRD ANGLE PROJECTION	

Regal Beloit America, Inc.	
DESCRIPTION	MODEL-RFHP-48FR OUTLINE
MATERIAL	
SIZE	C
DWG NO	FML1036
SHEET	1