

PRODUCT INFORMATION PACKET



Model No: FE1026SC

Catalog No: FE1026SC

Condenser Fan Motor, 1/4 HP, 1 Ph, 60 Hz, 208-230 V, 1075 RPM, 1 Speed, 48 Frame, TEAO



Regal and Century are trademarks of Regal Rexnord Corporation or one of its affiliated companies.

©2023 Regal Rexnord Corporation, All Rights Reserved. MC017097E





Nameplate Specifications

Output HP	1/4 Hp	Output KW	0.19 kW
Frequency	60 Hz	Voltage	208-230 V
Current	1.75 A	Speed	1075 rpm
Service Factor	1	Phase	1
Duty	Air Over	Insulation Class	B
Frame	48Y	Enclosure	Totally Enclosed Air Over
Thermal Protection	Automatic	Ambient Temperature	60 °C
UL	Recognized	CSA	Y
CE	N	Number of Speeds	1

Technical Specifications

Electrical Type	Permanent Split Capacitor	Starting Method	Across The Line
Poles	6	Rotation	Reversible
Mounting	Extended Studs	Motor Orientation	Any
Drive End Bearing	Ball	Opp Drive End Bearing	Ball
Frame Material	Steel	Shaft Type	Flat
Overall Length	10.67 in	Frame Length	3.50 in
Shaft Diameter	0.500 in	Shaft Extension	6.0 in
Connection Drawing	614131-242	Outline Drawing	FE1026SC_FA

This is an uncontrolled document once printed or downloaded and is subject to change without notice. Date Created:02/16/2023

GENERAL INFORMATION:

SHAFT RUNOUT: .001[.03] T.I.R. PER INCH LENGTH OF EXTENSION

BEARINGS: BALL

MOUNTING POSITION: ALL ANGLE

ELECTRICAL DATA:

OVERLOAD PROTECTOR: AUTOMATIC RESET (T.I. 7AM 036)

LEADS: NO. 18 GA., .03 [.8] THK. XLP 125°C INSUL.

REVERSING PLUGS: NO. 18 GA., .03 [.8] THK. XLP 125°C INSUL.

GROUND LEAD: NO. 18 GA., .03 [.8] THK. (GREEN) INSUL.

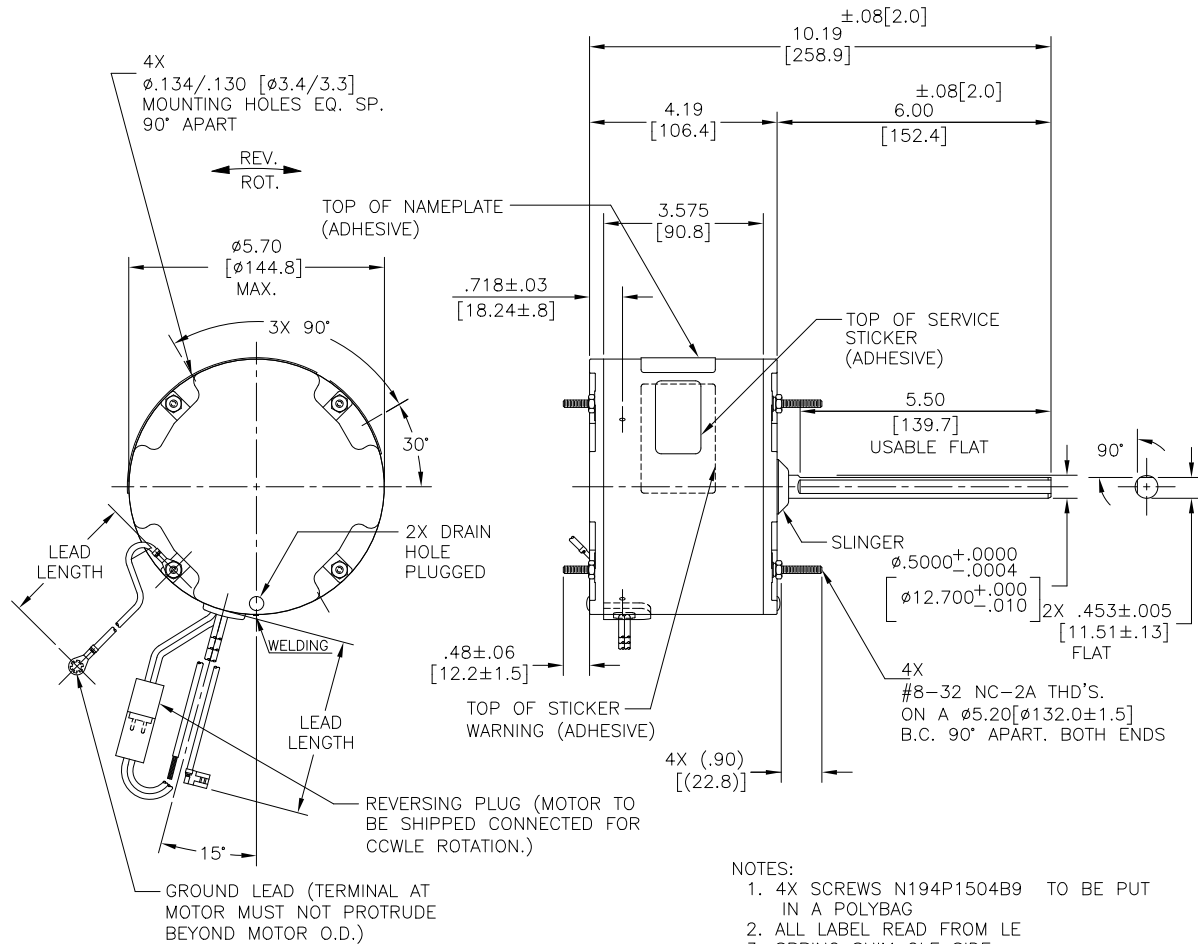

- NOTES:
1. 4X SCREWS N194P1504B9 TO BE PUT IN A POLYBAG
 2. ALL LABEL READ FROM LE
 3. SPRING SHIM OLE SIDE

SAMPLE SM19-380
NAMEPLATE DATA:

MODEL NO.: 5KCP39FGDD671S
CUST. P/N: FE1026SC
HP: 1/4
ROT.: REVERSIBLE
RPM: 1075
TYPE: UF
FRAME: 48Y
VOLTS: 208-230
PH: 1
AMPS: 1.75
HZ: 60
INS.: B
AMB.: 60° C
DUTY: AIR OVER
CAP.: 5 MFD/370V
THERMALLY PROTECTED

EXTERNAL CONNECTION
DIAGRAM

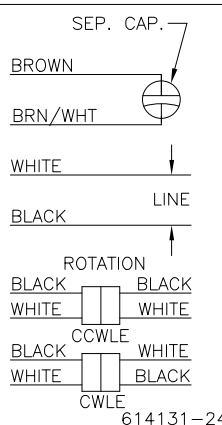

COLOR	LENGTH	TERMINAL OR STRIP LENGTH
GREEN (GROUND)	12.0/13.0 [305/330]	#10 EYELET
BLACK/WHITE	3.0/5.0 [76/127]	REVERSING PLUG
BROWN	26.0/28.0 [660/711]	.25[6.4] FLAG
BROWN/WHITE	26.0/28.0 [660/711]	.25[6.4] FLAG
WHITE	26.0/28.0 [660/711]	.50 [12.7] SKIN
BLACK	26.0/28.0 [660/711]	.50 [12.7] SKIN
COLOR	LENGTH	TERMINAL OR STRIP LENGTH

REGAL-BELOIT CORPORATION (RBC) PROVIDES TECHNICAL ASSISTANCE TO OUR CUSTOMERS IN SEVERAL AREAS. SINCE RBC DOES NOT RECEIVE ALL DATA CONCERNING THE USE AND APPLICATION OF THE MOTOR, THE SUITABILITY OF THE MOTOR FOR THE APPLICATION MUST BE DETERMINED BY THE CUSTOMER.

DIMENSIONS WITHOUT TOLERANCES ARE FOR REFERENCE ONLY.

MAIN FRAME - OLE	ENCLOSED
END FRAME - OLE	ENCLOSED
MAIN FRAME - LE	ENCLOSED
END FRAME - LE	ENCLOSED

CUSTOMER DISTRIBUTION SERVICE

MADE IN INDIA

E27885
614131-242

DRAWING REVISION	REVISION BY	DATE
1	MG	15-04-22
2	LS	15-04-22

ECO DESCRIPTION
ENERGY CONSERVATIONIST STICKER IS REMOVED

COPYRIGHT REGAL-BELOIT AMERICA, INC. ALL RIGHTS RESERVED. PROPRIETARY AND CONFIDENTIAL INFORMATION - THIS DOCUMENT IS THE PROPERTY OF REGAL-BELOIT AMERICA, INC. (OWNER) AND CONTAINS OWNER'S PROPRIETARY INFORMATION. ANY PERSON, CORPORATION OR OTHER ENTITY, DUPLICATED, AND/OR USED, WITHOUT THE EXPRESS WRITTEN APPROVAL OF REGAL-BELOIT AMERICA, INC. SHALL BE SUBJECT TO A LITIGATION. THIS DOCUMENT SHALL BE RETURNED TO OWNER UPON REQUEST. IT MAY BE SUBJECT TO CERTAIN RESTRICTIONS UNDER APPLICABLE EXPORT CONTROL LAWS AND REGULATIONS.

DRAWN BY:	MK
DATE:	10.10.19
APPROVED BY:	LS
DATE:	10.10.19
PROCESS/FINISH	
THIRD ANGLE PROJECTION	

Regal Beloit America, Inc.	
DESCRIPTION	MODEL-RFHP-48FR OUTLINE
MATERIAL	-
SIZE	DWG NO C FE1026SC_FA
SHEET	1



NOTES:

1. FOR USE WITH 614129 NAMEPLATE BLANK
2. — — — — — INDICATES DIMENSION LIMITS
3. DIE TO BE MADE FROM MASTER SUPPLIED BY REGAL REXNORD CORPORATION
4. DIE MUST PRODUCE A LEGIBLE IMPRESSION.

DRAWING REVISION H	REVISION BY J. RUPERT	DATE 03-16-2022
ECO NMR-0213140	APPROVED BY J. RUPERT	DATE 03-16-2022

TOLERANCES UNLESS OTHERWISE SPECIFIED			
DEC.	INCH	mm	ANGLE
.X	±0.1	[±2.5]	±0.5°
.XX	±0.02	[±0.51]	
.XXX	±0.005	[±0.127]	
.XXXX	±0.0005	[±0.0127]	
REMOVE BURRS & BREAK SHARP EDGES .003/.015 [0.076/.381] X 45°			
CORNER FILLETS R.02 [.51]			
MACHINED SURFACES			
	INCH	mm	
	125	3.2	
mm SHOWN IN [BRACKETS]			

DRAWN BY: YL	THIRD ANGLE PROJECTION
DATE: 04-15-2011	
APPROVED BY: HZ	
DATE: 04-15-2011	
REFERENCE	

Regal Beloit America, Inc.	
DESCRIPTION CONNECTION DIAGRAM EXTERNAL	
MATERIAL	PROCESS/FINISH
SIZE A	DWG NO 4 of 4
614131-242	
SHEET 1	

ECO DESCRIPTION
REVISED FOR UP ISSUED

COPYRIGHT REGAL BELOIT AMERICA, INC. ALL RIGHTS RESERVED. PROPRIETARY AND CONFIDENTIAL INFORMATION - THIS DOCUMENT IS THE PROPERTY OF REGAL BELOIT AMERICA, INC. ("OWNER") AND CONTAINS OWNER'S PROPRIETARY INFORMATION. ANY PERSON, CORPORATION OR OTHER FIRM RECEIVING IT IS DEEMED, BY RECEIVING IT, TO AGREE THAT IT, AND/OR ANY PART OF IT, SHALL NOT BE DISCLOSED TO ANY PERSON, CORPORATION OR OTHER ENTITY, DUPLICATED, AND/OR USED, EXCEPT AS EXPRESSLY APPROVED IN WRITING IN ADVANCE BY OWNER. THIS DOCUMENT SHALL BE RETURNED TO OWNER UPON REQUEST. IT MAY BE SUBJECT TO CERTAIN RESTRICTIONS UNDER APPLICABLE EXPORT CONTROL LAWS AND REGULATIONS.