

PRODUCT INFORMATION PACKET



Model No: F1076A
Catalog No: F1076A

Condenser Fan Motor, 3/4 HP, 1 Ph, 60 Hz, 208-230 V, 1075/750 RPM, 2 Speed, 48 Frame, SEMI ENCLOSED



Regal and Century are trademarks of Regal Rexnord Corporation or one of its affiliated companies.
©2023 Regal Rexnord Corporation, All Rights Reserved. MC017097E





Nameplate Specifications

Output HP	3/4 Hp	Output KW	0.56 kW
Frequency	60 Hz	Voltage	208-230 V
Current	3.5 A	Speed	1075/750 rpm
Service Factor	1	Phase	1
Duty	Air Over	Insulation Class	B
Frame	48Y	Enclosure	Semi Enclosed
Thermal Protection	Automatic	Ambient Temperature	60 °C
UL	Recognized	CSA	Y
CE	N	Number of Speeds	2

Technical Specifications

Electrical Type	Permanent Split Capacitor	Starting Method	Across The Line
Poles	6	Rotation	Reversible
Mounting	Extended Studs	Motor Orientation	Any
Drive End Bearing	Ball	Opp Drive End Bearing	Ball
Frame Material	Rolled Steel	Shaft Type	Keyed
Overall Length	10.19 in	Frame Length	4.75 in
Shaft Diameter	0.625 in	Shaft Extension	4.4 in
Outline Drawing	F1076A	Connection Drawing	614131-104

This is an uncontrolled document once printed or downloaded and is subject to change without notice. Date Created:02/16/2023

4

3

2

1

REV	ECO	REV BY	DATE	APPD	DATE
A	0010974	R.RASCON	12-03-2009	C.CONTRERAS	12-03-2009

GENERAL INFORMATION:

SHAFT RUNOUT: .001 [.03] T.I.R. PER INCH LENGTH OF EXTENSION

BEARINGS: BALL

MOUNTING POSITION: HORIZONTAL

ELECTRICAL DATA:

OVERLOAD PROTECTOR: AUTOMATIC RESET (T.I. 7AM 034)

LINE LEADS: NO. 18 GA., .06 [1.5] THK. XLP 125°C INSUL.

REVERSING PLUGS: NO. 18 GA., .03 [.8] THK. XLP 125°C INSUL.

GROUND LEAD: NO. 18 GA., .03 [.8] THK. (GREEN) INSUL.

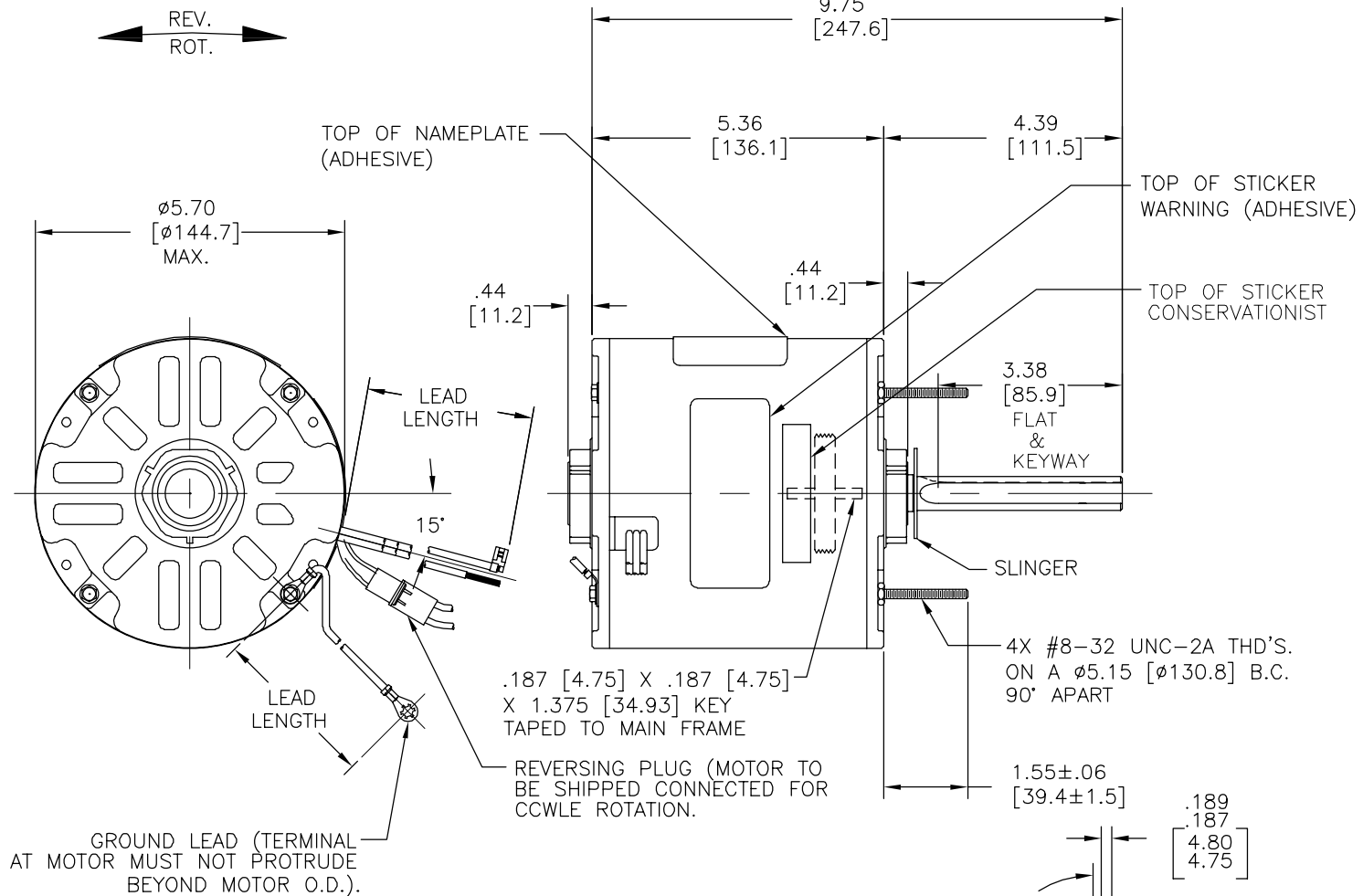

GREEN (GROUND)	12.0/13.0 [305/330]	#10 EYELET
BLACK/WHITE	3.0/5.0 [76/127]	REVERSING PLUG
BROWN	26.0/28.0 [660/711]	.25 [6.4] FLAG
YELLOW	26.0/28.0 [660/711]	.60 [15.2] SKIN
BLACK	26.0/28.0 [660/711]	.60 [15.2] SKIN
RED	26.0/28.0 [660/711]	.60 [15.2] SKIN
COLOR	LENGTH	TERMINAL OR STRIP LENGTH

NAMEPLATE DATA:	EXTERNAL CONNECTION DIAGRAM
MODEL NO.: F48SQ6V48 CUST. P/N: F1076A HP: 3/4 ROT.: REVERSIBLE RPM: 1075/750 TYPE: UF FRAME: 48Y VOLTS: 208-230 PH: 1 AMPS: 3.5 (4.2 MAX.) HZ: 60 INS.: B AMB.: 60° C DUTY: AIR OVER CAP.: 15 MFD/370 V ENCL: SEMI-ENCL. UL LOGO CSA LOGO THERMALLY PROTECTED	

PERFORMANCE CURVE NO.	TORQUE @ 1075 RPM (25°C)	APPROVED SAMPLE	UL COMPONENT		CSA	
C23138	68.8 OZ. FT.	EX11301	FILE #	CCN #	FILE #	CLASS #
			E46412	PRGY2	LR43341	4211-01

MAIN FRAME - OLE	ENCLOSED
END FRAME - OLE	ENCLOSED
MAIN FRAME - LE	ENCLOSED
END FRAME - LE	OPEN

CUSTOMER	DISTRIBUTION SERVICE
----------	----------------------

GEOMETRIC CHARACTERISTICS & SYMBOLS
 ▽ FLATNESS
 — STRAIGHTNESS
 ∠ ANGULARITY
 ⊥ PERPENDICULARITY (SQUARENESS)
 // PARALLELISM
 ○ ROUNDNESS (CIRCULARITY)
 ⌀ CYLINDRICITY
 △ PROFILE OF ANY SURFACE
 ∩ PROFILE OF ANY LINE
 ↗ RUNOUT
 ⊕ TRUE POSITION
 ⊙ CONCENTRICITY
 = SYMMETRY

A.O. SMITH PROVIDES TECHNICAL ASSISTANCE TO OUR CUSTOMERS IN SEVERAL AREAS. SINCE A.O. SMITH DOES NOT RECEIVE ALL DATA CONCERNING THE USE AND APPLICATION OF THE MOTOR, THE SUITABILITY OF THE MOTOR FOR THE APPLICATION MUST BE DETERMINED BY THE CUSTOMER.
 DIMENSIONS WITHOUT TOLERANCES ARE FOR REFERENCE ONLY.

DR BY: R.RASCON 12-03-2009
 APPD: C.CONTRERAS 12-03-2009
 THIRD ANGLE PROJECTION
 CONFIDENTIAL: THIS DRAWING AND ITS INFORMATION ARE THE EXCLUSIVE AND CONFIDENTIAL PROPERTY OF A.O. SMITH CORP. AND ARE NOT TO BE DISCLOSED, DUPLICATED, DISTRIBUTED OR OTHERWISE USED WITHOUT THE WRITTEN CONSENT OF A.O. SMITH CORP.
 -ALL RIGHTS RESERVED. ASME Y14.5M 1994

AC Smith **ELECTRICAL PRODUCTS COMPANY**
 Innovation has a name. A DIVISION OF A. O. SMITH CORPORATION

DESCRIPTION: **OUTLINE**

SIZE: C DWG NO: F1076A

SCALE: NONE SHEET: 1

4

3

2

1

4

3

2

1

REVISION:	ECO	REVISADO POR:	FECHA:	APROBADO POR:	FECHA:
A	0010974	R.RASCON	12-03-2009	C.CONTRERAS	12-03-2009

INFORMACION GENERAL:

OSCILACION DE FLECHA: .001 [.03] T.I.R. PER INCH LENGTH OF EXTENSION

BALEROS: BALINES

POSICION DEL MONTAJE: HORIZONTAL

INFORMACION ELECTRICA:

PROTECTOR DE SOBRECARGA: REINICIO AUTOMATICO (T.I. 7AM 034)

CABLES: NO. 18 GA., .06 [1.5] THK. XLP 125°C AISLAM.

CONEXION REVERSIBLE: NO. 18 GA., .03 [.8] THK. XLP 125°C AISLAM.

CABLE DE TIERRA: NO. 18 GA., .03 [.8] THK. (VERDE) AISLAM.

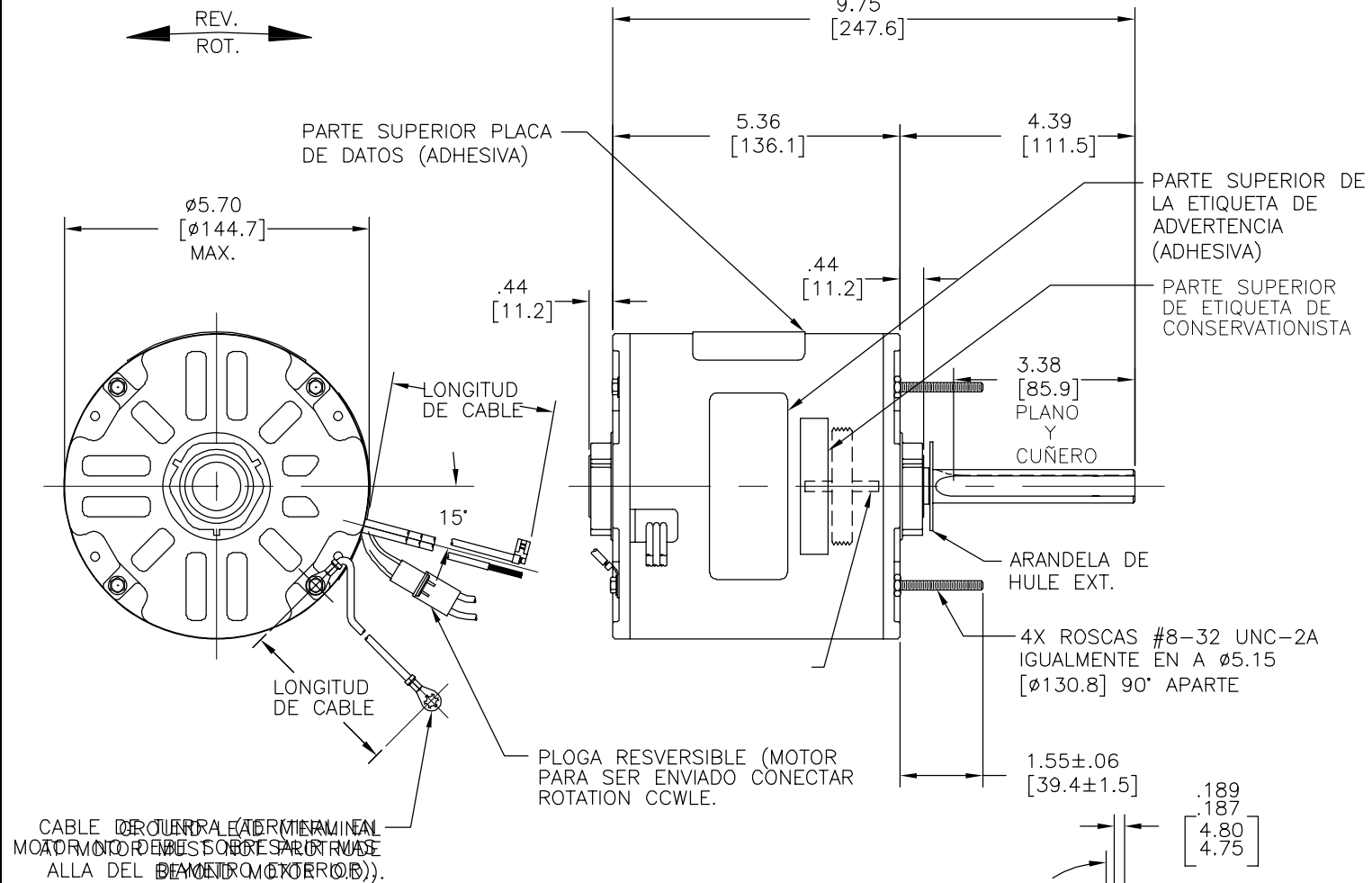

VERDE (TIERRA)	12.0/13.0 [305/330]	OJAL #10
NEGRO/BLANCO	3.0/5.0 [76/127]	CONEXION REVERSIBLE
CAFE	26.0/28.0 [660/711]	.25 [6.4] BANDERA
AMARILLO	26.0/28.0 [660/711]	.60 [15.2] DEL PIEL
NEGRO	26.0/28.0 [660/711]	.60 [15.2] DEL PIEL
ROJO	26.0/28.0 [660/711]	.60 [15.2] DEL PIEL
COLOR	LONGITUD	TERMINAL O LONGITUD DE DESFORRE

CARCASA - LOC	ENCERRADO
TAPA - LOC	ENCERRADO
CARCASA - LC	ENCERRADO
TAPA - LC	ABIERTA

CLIENTE	DISTRIBUTION SERVICE
---------	----------------------

INFORMACION DE ETIQUETA:	DIAGRAMA DE CONEXION EXTRNA
MODEL NO.: F48SQ6V48 CUST. P/N: F1076A HP: 3/4 ROT.: REVERSIBLE RPM: 1075/750 TYPE: UF FRAME: 48Y VOLTS: 208-230 PH: 1 AMPS: 3.5 (4.2 MAX.) HZ: 60 INS.: B AMB.: 60° C DUTY: AIR OVER CAP.: 15 MFD/370 V ENCL: SEMI-ENCL. UL LOGO CSA LOGO THERMALLY PROTECTED	

CURVAS DE FUNCIONAMIENTO	TORSION @ 1075 RPM (25°C)	MUESTRA APROBADA	COMPONENTE UL	CSA
C23138	68.8 OZ. FT.	EX11301	#ARCHIVO PRGY2	CLASE # 4211-01

CARACTERISTICAS DE GEOMETRIA Y SIMBOLOS

- ∠ PLANICIDAD
- RECTITUD
- ∠ ANGULARIDAD
- ⊥ PERPENDICULARIDAD (A ESQUADRA)
- // PARALELISMO
- REDONDEZ (CIRCULARIDAD)
- ∅ CILINDRICIDAD
- △ PERFIL DE CUALQUIER SUPERFICIE
- ∩ PERFIL DE CUALQUIER LINEA
- ∧ VARIACION
- ⊕ POSICION REAL
- ◎ CONCENTRICIDAD
- ≡ SIMETRIA

A.O. SMITH PROVEE ASISTENCIA TECNICA A NUESTROS CLIENTES EN VARIAS AREAS. DESDE QUE A.O. SMITH NO RECIBE TODOS LOS DATOS EN RELACION AL USO Y A LA APLICACION DEL MOTOR, LA APLICACION ADECUADA DEL MOTOR DEBE SER DETERMINADA POR EL CLIENTE.

DIMENSIONES SIN TOLERANCIA SON DE REFERENCIA SOLAMENTE

DIBUJADO POR: R.RASCON 12-03-2009

APROBADO POR: C.CONTRERAS 12-03-2009

TERCER ANGULO DE PROYECCION

FECHA EDS: EDS DATE

REV. FORMATO: F

CONFIDENCIAL: ESTE DIBUJO Y SU INFORMACION SON PROPIEDAD DE USO EXCLUSIVO Y CONFIDENCIAL DE A.O.SMITH CORP. Y NO DEBERAN SER REVELADOS, DUPLICADOS, DISTRIBUIDOS O USARSE DE OTRA MANERA SIN EL CONSENTIMIENTO ESCRITO DE A.O. SMITH CORP. -TODOS LOS DERECHOS RESERVADOS.ASME Y14.5M 1994

AC Smith **ELECTRICAL PRODUCTS COMPANY**
Innovation has a name. A DIVISION OF A. O. SMITH CORPORATION

DESCRIPCION: **OUTLINE**

TAMAÑO: C NUMERO DE DIBUJO: F1076A

ESCALA: NONE HOJA: 1

4

3

2

1

4 3 2 1

总技术要求:
 轴跳动: .001[.03]/1[25.4]外伸轴
 轴承: ???
 安装位置: 水平

电气数据:
 过载保护: 自动复位 (T. I. 7AM 034)
 引线: 18# (美制标准), 厚.06[1.5] XLP 125° C 绝缘
 换向线: 18# (美制标准), 厚.03[0.8] XLP 125° C 绝缘
 接地线: 18# (美制标准), 厚.03[0.8]绿色绝缘

铭牌数据	外部数据线
MODEL NO.: F48SQ6V48 CUST. P/N: F1076A HP: 3/4 ROT.: REVERSIBLE RPM: 1075/750 TYPE: UF FRAME: 48Y VOLTS: 208-230 PH: 1 AMPS: 3.5 (4.2 MAX.) HZ: 60 INS.: B AMB.: 60° C DUTY: AIR OVER CAP.: 15 MFD/370 V ENCL: SEMI-ENCL. UL LOGO CSA LOGO THERMALLY PROTECTED	
	614131-104

性能曲线编号	转矩在 @ 1075 RPM (25° C)	批准样品	UL部件		CSA	
			文件号	??	文件号	??
C23138	68.8 OZ. FT.	EX11301	E46412	PRGY2	LR43341	4211-01

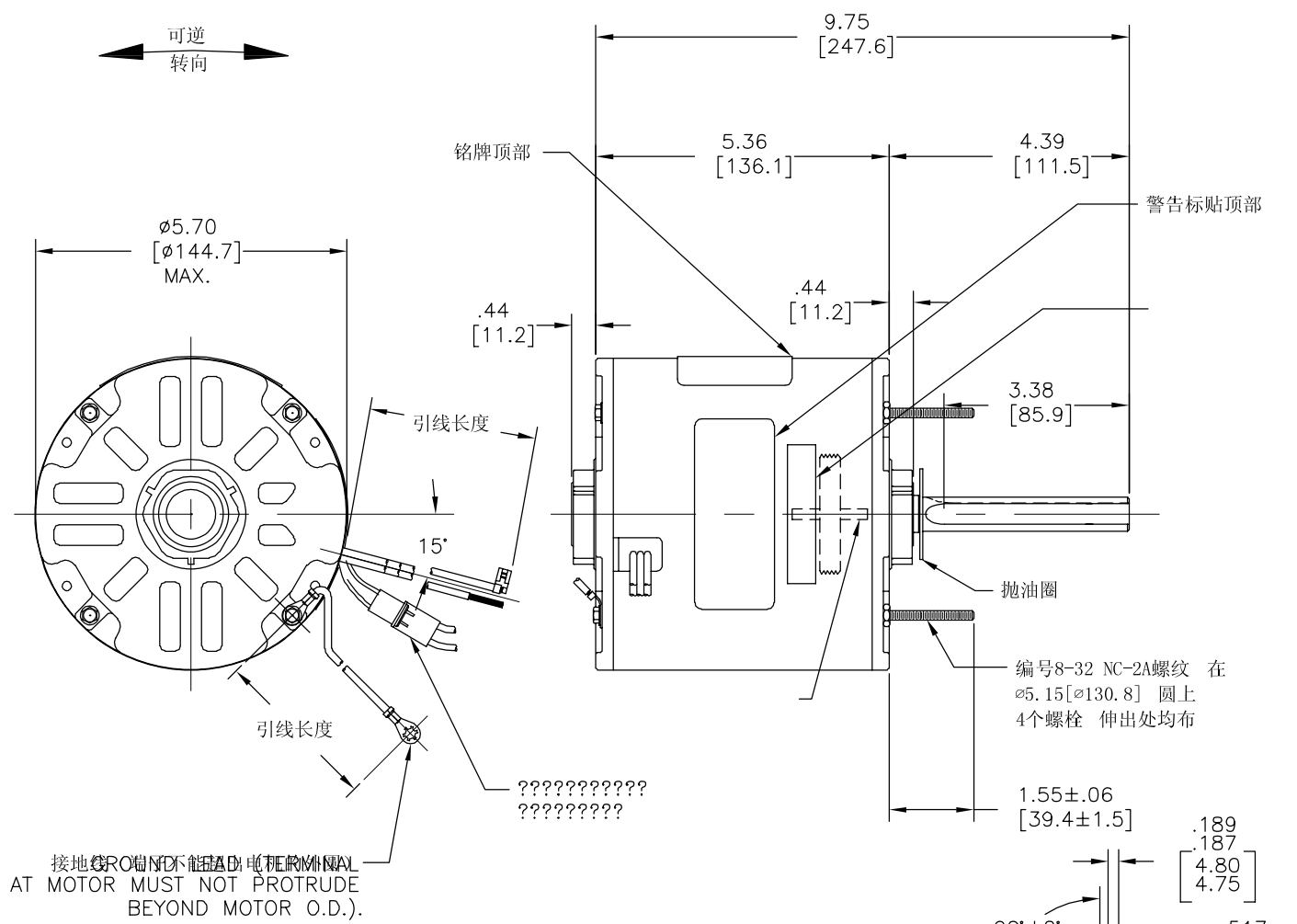

绿 (接地线)	12.0/13.0 [305/330]	#10 ???
黑/白	3.0/5.0 [76/127]	翻边插头
?	26.0/28.0 [660/711]	.25 [6.4] 旗形插
?	26.0/28.0 [660/711]	.60 [15.2] 剥皮
?	26.0/28.0 [660/711]	.60 [15.2] 剥皮
?	26.0/28.0 [660/711]	.60 [15.2] 剥皮
颜色	长度	端子或剥线长度

无引线端机壳	密封
无引线端端盖	密封
有引线端机壳	密封
有引线端端盖	??

????
 □???
 -???
 <???
 ↑???
 //???
 ○??
 /??
 △???
 ^???
 /???
 ⊕???
 ⊙???
 =???

A.O.SMITH?????
 ???????A.O.SMITH
 ???????
 ???????
 ???????
 ???????
 ???????

| | | |
|-------|-------------------------|---------------|
| ??: | R.RASCON | 12-03-2009 |
| ??: | C.CONTRERAS | 12-03-2009 |
| ????? | ⊕ | EDS DATE
F |
| ??: | ????????A.O.SMITH????? | |
| ??: | ??A.O.SMITH???????????? | |
| ??: | ?????--???? | |

ACSmith **ELECTRICAL PRODUCTS COMPANY**
 Innovation has a name. A DIVISION OF A. O. SMITH CORPORATION

OUTLINE

C F1076A

NONE 1

ASME Y14.5M 1994

4 3 2 1

| REV | ECO | REV BY | DATE | APPD | DATE |
|-----|-------------|---------|-----------|--------|------------|
| A | ECO-0018859 | jrupert | 02-21-011 | triley | 02-21-2011 |

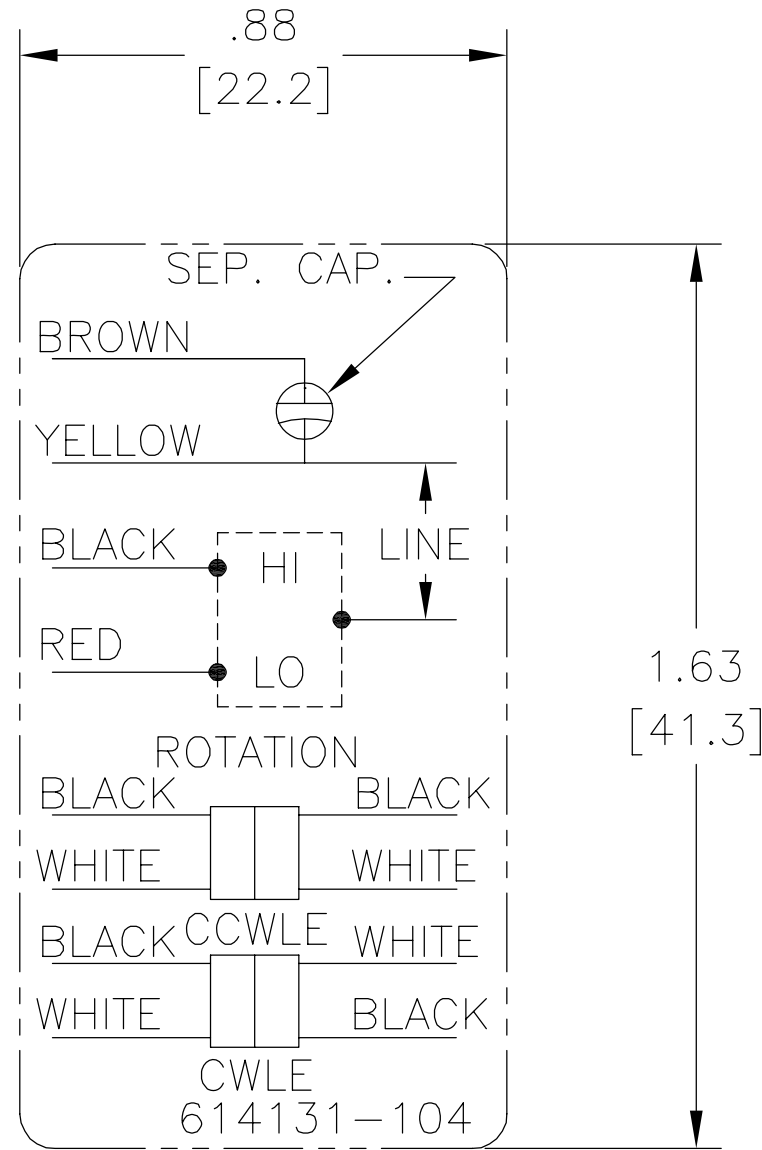

NOTES:

1. FOR USE WITH 614129 NAMEPLATE BLANK
2. — — — — — INDICATES DIMENSION LIMITS
3. DIE TO BE MADE FROM MASTER SUPPLIED BY A. O. SMITH CORPORATION
4. DIE MUST PRODUCE A LEGIBLE IMPRESSION.

GEOMETRIC CHARACTERISTICS & SYMBOLS

- ▭ FLATNESS
- STRAIGHTNESS
- ∠ ANGULARITY
- ⊥ PERPENDICULARITY (SQUARENESS)
- // PARALLELISM
- ROUNDNESS (CIRCULARITY)
- ⊘ CYLINDRICITY
- △ PROFILE OF ANY SURFACE
- ∩ PROFILE OF ANY LINE
- ↑ RUNOUT
- ⊕ TRUE POSITION
- ◎ CONCENTRICITY
- ≡ SYMMETRY

UNLESS OTHERWISE SPECIFIED
DIM. TOLERANCES ARE AS FOLLOWS:

| | | | | |
|------|------|-------|--------|--------|
| INCH | ±.1 | ±.02 | ±.005 | ±.0005 |
| mm | ±0.5 | ±0.13 | ±0.013 | |

ANG. ±.50 DEG

REMOVE BURRS & BREAK SHARP EDGES:
INCH .003-.015 mm 0.1-0.4

CORNER FILLETS TO:
INCH .020 mm 0.5

MACHINE SURFACES:
INCH 125 mm 3.2

METRIC DIMS. SHOWN IN [BRACKETS]

| | | |
|---|---------|-------------------------------------|
| DR BY: | jrupert | 02-21-2011 |
| APPD: | triley | 02-21-2011 |
| THIRD ANGLE PROJECTION | | EDS DATE 02-22-2008
FORMAT REV F |
| CONFIDENTIAL: THIS DRAWING AND ITS INFORMATION ARE THE EXCLUSIVE AND CONFIDENTIAL PROPERTY OF A.O. SMITH CORP. AND ARE NOT TO BE DISCLOSED, DUPLICATED, DISTRIBUTED OR OTHERWISE USED WITHOUT THE WRITTEN CONSENT OF A.O. SMITH CORP.
-ALL RIGHTS RESERVED. ASME Y14.5M 1994 | | |

| | | | |
|---|------|---|------------|
| AC Smith
Innovation has a name. | | ELECTRICAL PRODUCTS COMPANY
A DIVISION OF A. O. SMITH CORPORATION | |
| DESCRIPTION | | | |
| CONN DIAGRAM EXTERNAL | | | |
| SIZE | A | DWG NO | 614131-104 |
| SCALE | NONE | SHEET | 1 |

| | | | | | |
|-----------|-------------|---------------|-----------|---------------|------------|
| REVISION: | ECO | REVISADO POR: | FECHA: | APROBADO POR: | FECHA: |
| A | ECO-0018859 | jrupert | 02-21-011 | triley | 02-21-2011 |

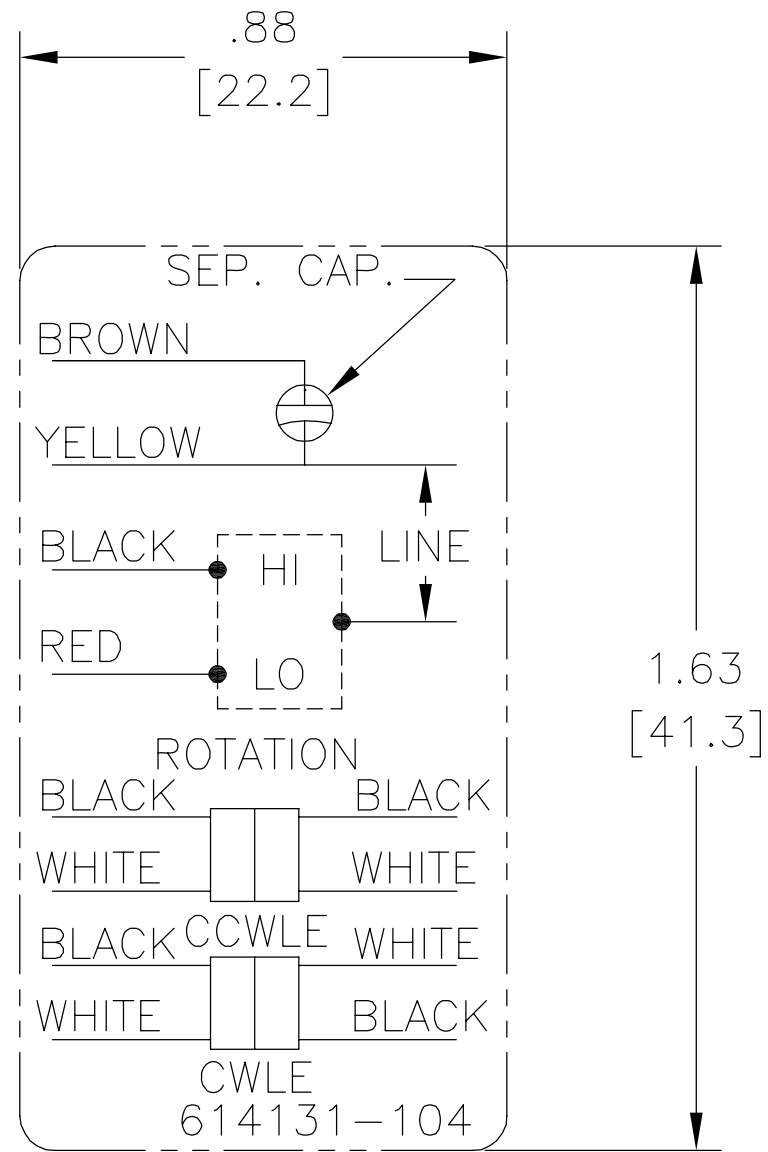

NOTES:

1. FOR USE WITH 614129 NAMEPLATE BLANK
2. ——— ——— INDICATES DIMENSION LIMITS
3. DIE TO BE MADE FROM MASTER SUPPLIED BY A. O. SMITH CORPORATION
4. DIE MUST PRODUCE A LEGIBLE IMPRESSION.

| | | | | |
|---|---|---|---|--|
| CARACTERISTICAS DE GEOMETRIA Y SIMBOLOS
▭ PLANICIDAD
— RECTITUD
< ANGULARIDAD
⊥ PERPENDICULARIDAD (A ESCUADRA)
// PARALELISMO
○ REDONDEZ (CIRCULARIDAD)
∅ CILINDRICIDAD
∩ PERFIL DE CUALQUIER SUPERFICIE
∪ PERFIL DE CUALQUIER LINEA
↑ VARIACION
⊕ POSICION REAL
⊙ CONCENTRICIDAD
= SIMETRIA | A MENOS QUE SE ESPECIFIQUE DE OTRA MANERA, LAS TOLERANCIAS DE LAS DIMS; SON LAS SIGUIENTES:
X XX XXX XXXX
PULG ±.1 ±.02 ±.005 ±.0005
mm ±0.5 ±0.13 ±0.013
ANG. ±.50 GRADOS
ELIMINAR REBABAS Y ORILLAS FILOSAS DEL BORDE.
PULG .003-.015 mm 0.1-0.4
FILETEAR ESQUINA: PULG .020 mm 0.5
MAQUINAR SUPERFICIES
PULG 125 mm 3.2
DIMS METRICAS MOSTRADAS [PARENTESIS] | DIBUJADO POR:
jrupert 02-21-2011
APROBADO POR:
triley 02-21-2011
TERCER ANGULO DE PROYECCION
(Third angle projection symbol) | FECHA EDS: 02-22-2008
REV. FORMATO: F | AC Smith
Innovation has a name.
ELECTRICAL PRODUCTS COMPANY
A DIVISION OF A. O. SMITH CORPORATION |
| | CONFIDENCIAL: ESTE DIBUJO Y SU INFORMACION SON PROPIEDAD DE USO EXCLUSIVO Y CONFIDENCIAL DE A.O.SMITH CORP. Y NO DEBERAN SER REVELADOS, DUPLICADOS, DISTRIBUIDOS O USARSE DE OTRA MANERA SIN EL CONSENTIMIENTO ESCRITO DE A.O. SMITH CORP.
-TODOS LOS DERECHOS RESERVADOS.ASME Y14.5M 1994 | DESCRIPCION:
CONN DIAGRAM EXTERNAL | TAMAÑO: A
NUMERO DE DIBUJO: 614131-104 | ESCALA: NONE
HOJA: 1 |

| | | | | |
|----|-------------|---------|-----------|--------|
| ?? | ECO | ?? | ?? | ?? |
| A | ECO-0018859 | jrupert | 02-21-011 | triley |

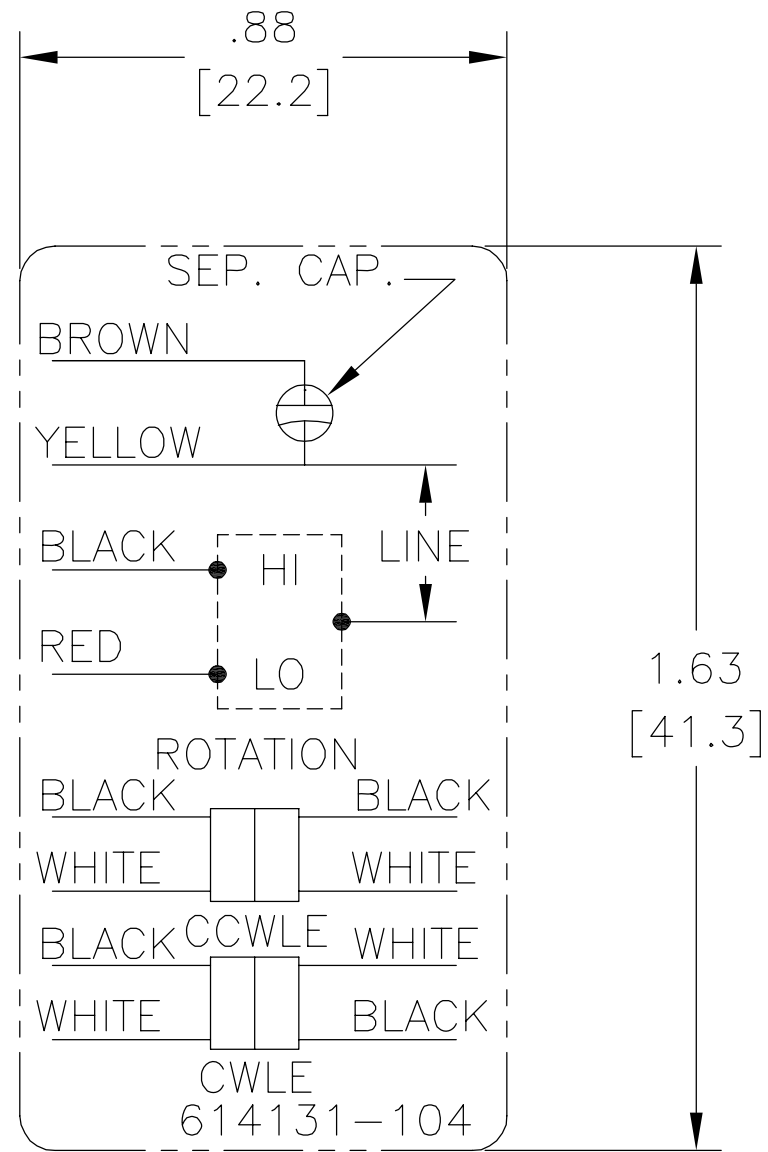

NOTES:

1. FOR USE WITH 614129 NAMEPLATE BLANK
2. ——— ——— INDICATES DIMENSION LIMITS
3. DIE TO BE MADE FROM MASTER SUPPLIED BY A. O. SMITH CORPORATION
4. DIE MUST PRODUCE A LEGIBLE IMPRESSION.

| | | |
|--|---|--|
| <p>????
 □ ???
 - ???
 < ???
 ⊥ ???
 // ???
 ○ ???
 ⊕ ???
 △ ???
 ∩ ???
 ↑ ???
 ⊕ ???
 ⊙ ???
 = ???</p> | <p>?????
 ???????
 ?? X XX XXX XXXX
 ?? ±.1 ±.02 ±.005 ±.0005
 ?? ±0.5 ±0.13 ±0.013
 ?? ±.50 ?
 ???????
 ?? .003-.015 ?? 0.1-0.4
 ???
 ?? .020 ?? 0.5
 ?????
 ?? 125 ?? 3.2
 ???????[]</p> | <p>??:
 jrupert 02-21-2011
 triley 02-21-2011
 ?????? 02-22-2008
 ?????? F
 ??: ?????????????A.O.SMITH?????
 ??A.O.SMITH????????????????????
 ??????—?????
 ASME Y14.5M 1994</p> |
|--|---|--|

| | | | |
|------------------------------|------|--|------------|
| | | <p>ELECTRICAL PRODUCTS COMPANY
 A DIVISION OF A. O. SMITH CORPORATION</p> | |
| <p>CONN DIAGRAM EXTERNAL</p> | | | |
| ?? | A | ?? | 614131-104 |
| ?? | NONE | ?? | 1 |