

5-5/8" Diameter Double Shaft Fan/Blower Motors

Room Air Conditioners - Fan Coils - Blowers

Features:

- Auto Protector
- Sleeve Bearing
- CCWLE Rotation
- Continuous Air Over
- Energy Efficient \$
- Permanent Split Capacitor
- Semi-enclosed Construction
- 60 HZ
- 1/2" Dia. Flatted Shafts

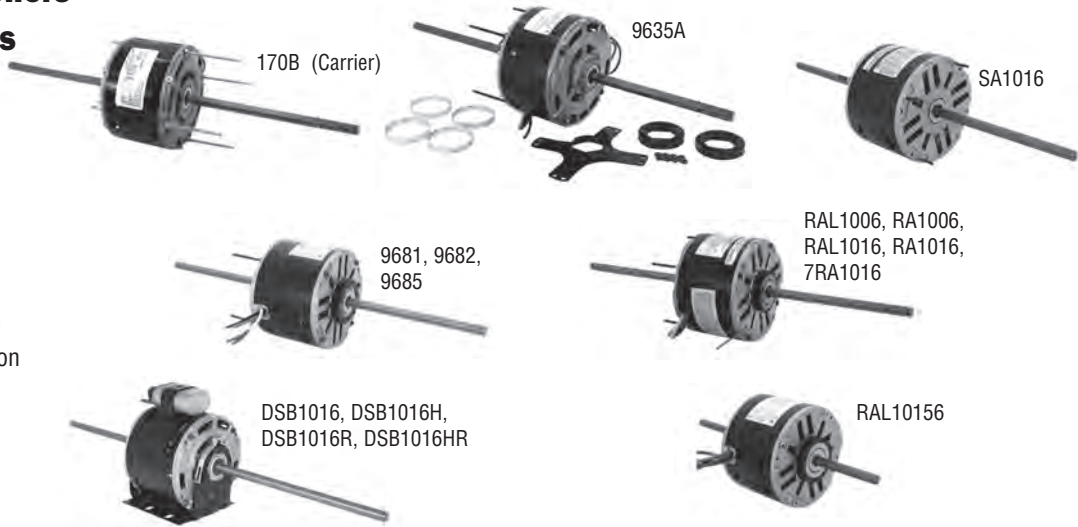

"CONSERVATIONIST™" (CAPACITOR NOT INCLUDED)

HP	RPM**	Speeds	Volts	Amps Rated	Stock Number	Capacitor	Dim. Ref.	Notes
1/15	1075	3	115	.63	RAL10156	3-5MFD/370V	5	\$
1/8	1075	3	115	2.0	RAL1006	5MFD-370V	1	6,24,29,\$
1/8	1075	3	208-230	.75	RA1006	5MFD-370V	1	6,24,31,\$
1/8	1550	3	115	2.3	9681	7.5MFD/370V	8	6,24,31,\$
1/8	1550	3	208-230	1.1	9682	7.5MFD/370V	8	6,24,31,\$
1/6	1075	3	115	2.2	RAL1016	5MFD-370V	2	6,24,31,\$
1/6	1075	3	115	3.1	DSB1016	Included	6	31,81,\$
1/6	1075	3	208-230	.96	RA1016	5MFD-370V	1	24,31,\$
1/6	1075	3	208-230	.96	SA1016	5MFD-370V	1	31,\$
1/6	1075	3	230	1.2	DSB1016H	Included	6	31,81,\$
1/6	1075	3	277	.8	7RA1016	5MFD-370V	3	24,31,\$
1/6	1550	3	115	2.7	9685	10MFD/370V	9	6,24,31,\$
1/6	1625	3	115	1.9	9635A	5MFD-370V	4	24,29,\$
1/6	1625	2	115	2.4	DSB1016R	Included	7	31,81,334,\$
1/6	1625	3	208-230	1.1	170B	5MFD-370V	4	3,29,\$
1/6	1625	2	230	1.3	DSB1016HR	Included	7	31,81,334,\$

Notes:

- 3. Special OEM Replacement Motor (see pages 94-132)
 - 6. 60/50 HZ
 - 24. Mounting Accessories Packaged with Motor
 - 29. 60°C Ambient
 - 31. 40°C Ambient
 - 81. Includes base
 - 334. Reversible
- **Approximately 150 RPM difference between speeds

Continues on next page

Approximate Dimensions

Ref.	BM	FC	N	N1
1	3.74	20	8.26	8
2	3.86	20	8.14	8
3	3.86	20	8.02	8.12
4	3.75	20.75	8.50	8.50
5	3.61	15.25	5.82	5.82
6	3.86	18.86	7.50	7.50
7	4.11	19.11	7.50	7.50
8	3.86	19.37	7.51	8.00
9	3.99	20	7.51	8.50

Minimum R = BM + 3/4"
Maximum R = BM + 2"

