

PRODUCT INFORMATION PACKET



Model No: DCL4421

Catalog No: DCL4421

Fan Coil & Air Conditioner Motor, 1/10,1/15,1/25 HP, 1 Ph, 60 Hz, 115 V, 1550 RPM, 3 Speed,
42 Frame, OPEN



Regal and Century are trademarks of Regal Rexnord Corporation or one of its affiliated companies.

©2023 Regal Rexnord Corporation, All Rights Reserved. MC017097E





Nameplate Specifications

Phase	1	Output HP	1/10,1/15,1/25 Hp
Output KW	0.07 kW	Voltage	115 V
Speed	1550 rpm	Service Factor	1
Frame	42Y	Enclosure	Open Enclosed
Thermal Protection	Automatic	Ambient Temperature	40 °C
Frequency	60 Hz	Current	3.5 A
Duty	Continuous	Insulation Class	B
UL	Recognized	CSA	Y
CE	N	Number of Speeds	3

Technical Specifications

Electrical Type	Shaded Pole	Starting Method	Across The Line
Poles	4	Rotation	Counterclockwise Lead End
Mounting	Resilient Rings	Motor Orientation	Horizontal
Drive End Bearing	Sleeve	Opp Drive End Bearing	Sleeve
Frame Material	Na	Shaft Type	Flat
Overall Length	18.00 in	Shaft Diameter	0.500 in
Shaft Extension	7.3 X.5 X7.3 in		
Connection Drawing	7559A83F01	Outline Drawing	DCL4421-S01

This is an uncontrolled document once printed or downloaded and is subject to change without notice. Date Created:05/27/2023

GENERAL INFORMATION:

SHAFT RUNOUT: .001 [.03] T.I.R. PER INCH LENGTH OF EXTENSION

END PLAY: .010 [.25] TO .063 [1.60]

BEARINGS: SLEEVE

MOUNTING POSITION: HORIZONTAL

ELECTRICAL DATA:

OVERLOAD PROTECTOR: AUTOMATIC RESET (SENSATA 7AM 304)

LEADS: NO. 18 GA., .03 [.8] THK., 125°C INSULATION

GROUND LEAD: NO. 18 GA., .03 [.8] THK., GREEN INSULATION

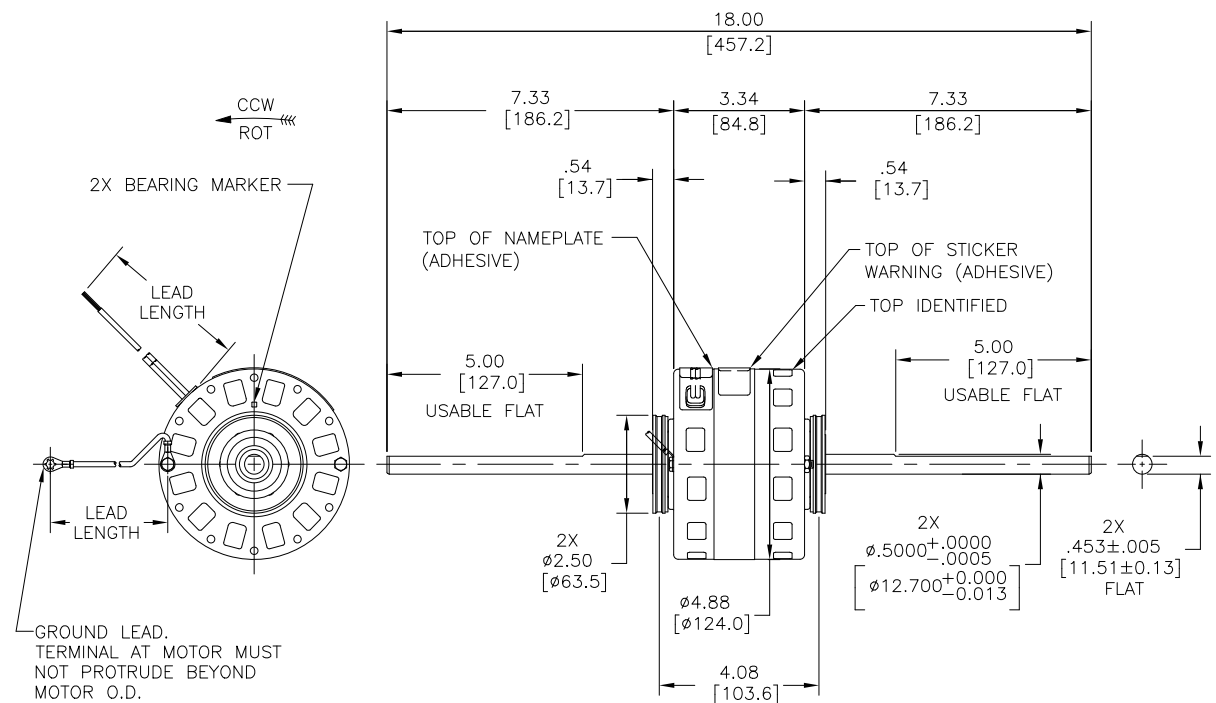

NAMEPLATE DATA:	EXTERNAL CONNECTION DIAGRAM
MODEL NO.: 326P151 CUST. P/N: DCL4421 HP: 1/10, 1/15, 1/25 ROT.: CCWLE RPM: 1550/3 SPD. TYPE: FE FRAME: 42Y VOLTS: 115 PH: 1 AMPS: 3.5 HZ: 60 INS.: B AMB.: 40° C DUTY: AIR OVER CAP.: - ENCL.: - UL LOGO CSA LOGO THERMALLY PROTECTED TYPE C	

COLOR	LENGTH	TERMINAL OR STRIP LENGTH
GREEN (GRD)	5.5/6.5 [140/165]	#10 EYELET
RED	53.0/57.0 [1346/1448]	.50 [12.7] SKIN
BLUE	53.0/57.0 [1346/1448]	.50 [12.7] SKIN
WHITE	53.0/57.0 [1346/1448]	.50 [12.7] SKIN
BLACK	53.0/57.0 [1346/1448]	.50 [12.7] SKIN

MAIN FRAME - OLE	OPEN
END FRAME - OLE	OPEN
MAIN FRAME - LE	OPEN
END FRAME - LE	OPEN

PERFORMANCE CURVE NO.	TORQUE @ 1550 RPM (25°C)	APPROVED SAMPLE	UL COMPONENT FILE #	CCN #	CSA FILE #	CLASS #
C30179	5.6 OZ. FT.	A7035B	E27885	XEWR2	LR43341	4211-01

DRAWING REVISION	REVISION BY	DATE
H	J. RUPERT	05-19-2023
ECO	APPROVED BY J. RUPERT	DATE: 05-19-2023
ECO DESCRIPTION	CHANGED UL FILE NUMBER	

DRAWN BY	DATE
W. HEATH	10-14-1987
APPROVED BY:	M. FRENCH
DATE:	10-14-1987
REFERENCE	326P151-OL
THIRD ANGLE PROJECTION	

Regal Beloit America, Inc.	
DESCRIPTION	
MODEL42FR-RFHP OUTLINE	
MATERIAL	PROCESS/FINISH
SIZE DWG NO	DCL4421
SHEET	1