

PRODUCT INFORMATION PACKET



Model No: C314

Catalog No: C314

1.5 HP General Purpose Farm Duty Motor, 1 phase, 1800 RPM, 230/115 V, 56 Frame, TEFC
General Purpose Farm Duty Motors



Regal and Century are trademarks of Regal Rexnord Corporation or one of its affiliated companies.
©2021 Regal Rexnord Corporation, All Rights Reserved. MC017097E





Nameplate Specifications

Output HP	1.5 Hp	Output KW	1.1 kW
Frequency	60 Hz	Voltage	230/115 V
Current	7.5/15.0 A	Speed	1725 rpm
Service Factor	1.15	Phase	1
Duty	Continuous	Insulation Class	B
Frame	M56	Enclosure	Totally Enclosed Fan Cooled
Thermal Protection	Thermally Protected	Ambient Temperature	40 °C
UL	Recognized	CSA	Y
CE	N	Number of Speeds	1

Technical Specifications

Electrical Type	Capacitor Start, Capacitor Run, Single Or Dual Voltage	Starting Method	Across The Line
Poles	4	Rotation	Reversible Counterclockwise
Mounting	Rigid Base	Drive End Bearing	Ball
Opp Drive End Bearing	Ball	Frame Material	Rolled Steel
Shaft Type	Keyed	Overall Length	13.86 in
Frame Length	6.75 in	Shaft Diameter	0.625 in
Shaft Extension	1.94 in		
Outline Drawing	195077-S01	Connection Drawing	17050307.PCX

This is an uncontrolled document once printed or downloaded and is subject to change without notice. Date Created:10/07/2021

REV	ECO	REV BY	DATE	APPD	DATE
C	0025361	L. BERNAL	04-12-2012	D. BALDERRAMA	04-12-2012

ALL DIMENSIONS SHOWN IN PARENTHESIS ARE REFERENCE DIMENSIONS. ALL OTHER DIMENSIONS ARE TOLERANCED PER THE FOLLOWING CHART UNLESS OTHERWISE SPECIFIED.

"C" DIM. = +/- .055
 SHAFT EXT. = +/- .034
 LEAD LENGTHS = +/- 1.00
 EXTENDED THRU-BOLTS = +/- .050
 ANGULAR DIM. = +/- 2'

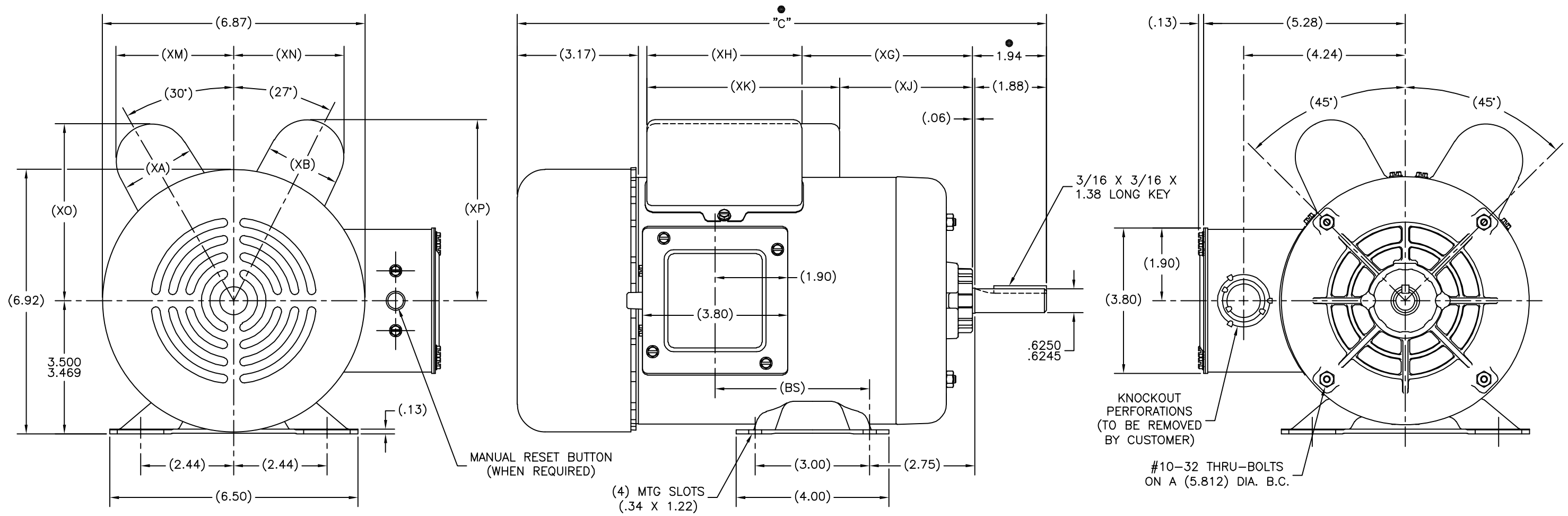

-03	CP	M56	13.86	4.05	2.01	2.01	3.47	5.06	3.47	5.06	3.09	2.89	4.63	4.74
-02	CSR	K56	12.61	2.80	2.01	2.01	3.22	4.06	3.22	4.06	3.09	2.89	4.63	4.74
-01	CSR	L56	13.36	3.55	2.01	2.01	3.97	4.06	3.97	4.06	3.09	2.89	4.63	4.74
GROUP	TYPE	FRAME	"C"	(BS)	(XA)	(XB)	(XG)	(XH)	(XJ)	(XK)	(XM)	(XN)	(XO)	(XP)

● = CRITICAL DIMENSION

GEOMETRIC CHARACTERISTICS & SYMBOLS
 □ FLATNESS
 ⊥ STRAIGHTNESS
 ∠ ANGULARITY
 ⊥ PERPENDICULARITY (SQUARENESS)
 // PARALLELISM
 ○ ROUNDNESS (CIRCULARITY)
 Ⓞ CYLINDRICITY
 ≡ PROFILE OF ANY SURFACE
 ≡ PROFILE OF ANY LINE
 Ⓢ RUNOUT
 ⊕ TRUE POSITION
 ⊙ CONCENTRICITY
 = SYMMETRY

UNLESS OTHERWISE SPECIFIED DIM. TOLERANCES ARE AS FOLLOWS:
 INCH ± .1 ± .02 ± .005 ± .0005
 mm ± 0.5 ± 0.13 ± 0.013
 ANG. ± 50 DEG
 REMOVE BURRS & BREAK SHARP EDGES:
 INCH .003-.015 mm 0.1-0.4
 CORNER FILLETS TO:
 INCH .020 mm 0.5
 MACHINE SURFACES:
 INCH 125 mm 3.2
 METRIC DIMS. SHOWN IN [BRACKETS]

DR BY: DAVHOL 12-14-1999
 APPD:
 THRD ANGLE PROJECTION
 EDS DATE 11-11-2011
 FORMAT REV G

REGAL-BELOIT CORPORATION
 DESCRIPTION 0056 DWG 0-LINE BB TEFC RIGID BASE
 SIZE D DWG NO 195077
 SCALE 1=1 SHEET 1

REVISION:	ECO	REVISADO POR:	L. BERNAL	FECHA:	04-12-2012	APROBADO POR:	D. BALDERRAMA	FECHA:	04-12-2012
C	0025361								

ALL DIMENSIONS SHOWN IN PARENTHESIS ARE REFERENCE DIMENSIONS. ALL OTHER DIMENSIONS ARE TOLERANCED PER THE FOLLOWING CHART UNLESS OTHERWISE SPECIFIED.

- "C" DIM. = +/- .055
- SHAFT EXT. = +/- .034
- LEAD LENGTHS = +/- 1.00
- EXTENDED THRU-BOLTS = +/- .050
- ANGULAR DIM. = +/- 2'

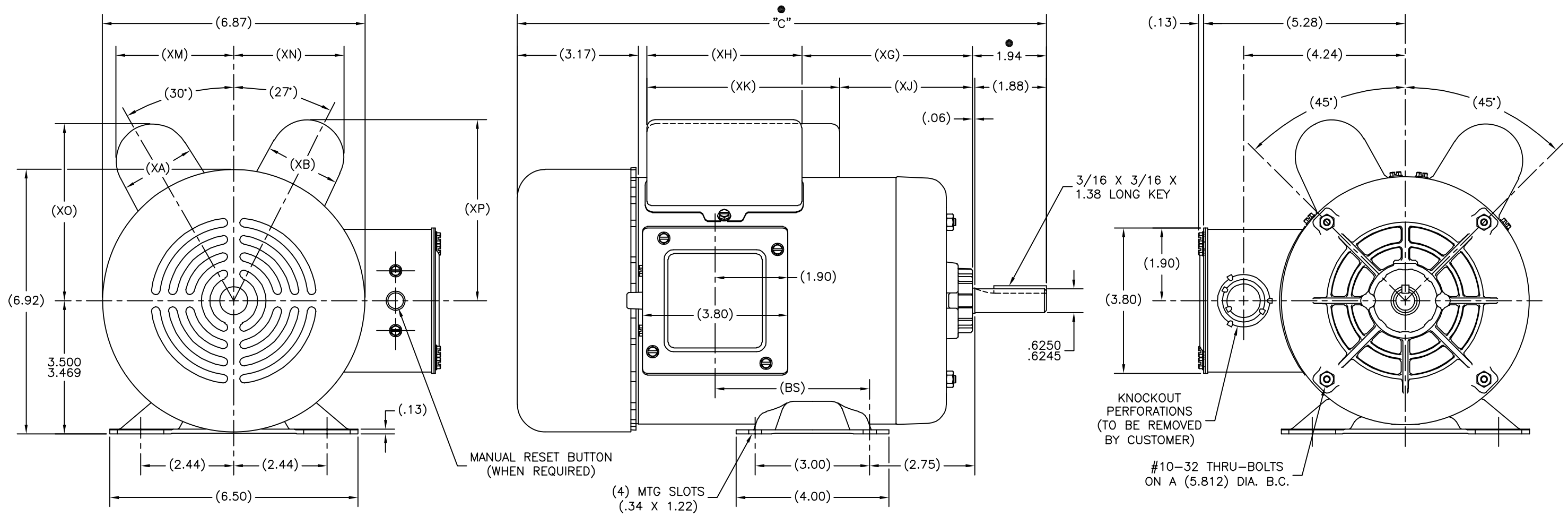

-03	CP	M56	13.86	4.05	2.01	2.01	3.47	5.06	3.47	5.06	3.09	2.89	4.63	4.74
-02	CSR	K56	12.61	2.80	2.01	2.01	3.22	4.06	3.22	4.06	3.09	2.89	4.63	4.74
-01	CSR	L56	13.36	3.55	2.01	2.01	3.97	4.06	3.97	4.06	3.09	2.89	4.63	4.74
GROUP	TYPE	FRAME	"C"	(BS)	(XA)	(XB)	(XG)	(XH)	(XJ)	(XK)	(XM)	(XN)	(XO)	(XP)

● = CRITICAL DIMENSION

CARACTERÍSTICAS DE GEOMETRIA Y SIMBOLOS:
 □ PLANICIDAD
 ⊥ RECTITUD
 ∠ ANGULARIDAD
 ⊥ PERPENDICULARIDAD (A ESCUADRA)
 // PARALELISMO
 ○ REDONDEZ (CIRCULARIDAD)
 ⌀ CILINDRICIDAD
 ≡ PERFIL DE CUALQUIER SUPERFICIE
 ⤴ PERFIL DE CUALQUIER LINEA
 ⤵ VARIACION
 ⊕ POSICION REAL
 ⊙ CONCENTRICIDAD
 = SIMETRIA

ASME Y14.5M 1994

A MENOS QUE SE ESPECIFIQUE DE OTRA MANERA, LAS TOLERANCIAS DE LAS DIMS; SON LAS SIGUIENTES:
 PULG ±.1 ±.02 ±.005 ±.0005
 mm ±0.5 ±0.13 ±0.013
 ANG ±.50 GRADOS
 ELIMINAR REBABAS Y ORILLAS FILOSAS DEL BORDE.
 PULG .003-.015 mm 0.1-0.4
 FILETEAR ESQUINA: PULG .020 mm 0.5
 MAQUINAR SUPERFICIES
 PULG 125 mm 3.2

DIMS METRICAS MOSTRADAS [PARENTESIS]

DIBUJADO POR: DAVHÖL
 APROBADO POR:
 TERCER ANGULO DE PROYECCION
 FECHA EDS: 11-11-2011
 REV. FORMATO: G

CONFIDENCIAL: ESTE DIBUJO Y SU INFORMACION SON PROPIEDAD DE USO EXCLUSIVO Y CONFIDENCIAL DE REGAL-BELOIT CORPORATION, Y NO DEBERAN SER REVELADOS, DUPLICADOS, DISTRIBUIDOS O USARSE DE OTRA MANERA SIN EL CONSENTIMIENTO ESCRITO DE REGAL-BELOIT CORPORATION. -TODOS LOS DERECHOS RESERVADOS.

REGAL-BELOIT CORPORATION
 DESCRIPCION: 0056 DWG O-LINE BB TEFC RIGID BASE
 TAMAÑO: D NUMERO DE DIBUJO: 195077
 ESCALA: 1=1 HOJA: 1

版本	ECO	编制	日期	批准	日期
C	0025361	L. BERNAL	04-12-2012	D. BALDERRAMA	04-12-2012

ALL DIMENSIONS SHOWN IN PARENTHESIS ARE REFERENCE DIMENSIONS. ALL OTHER DIMENSIONS ARE TOLERANCED PER THE FOLLOWING CHART UNLESS OTHERWISE SPECIFIED.

- "C" DIM. = +/- .055
- SHAFT EXT. = +/- .034
- LEAD LENGTHS = +/- 1.00
- EXTENDED THRU-BOLTS = +/- .050
- ANGULAR DIM. = +/- 2'

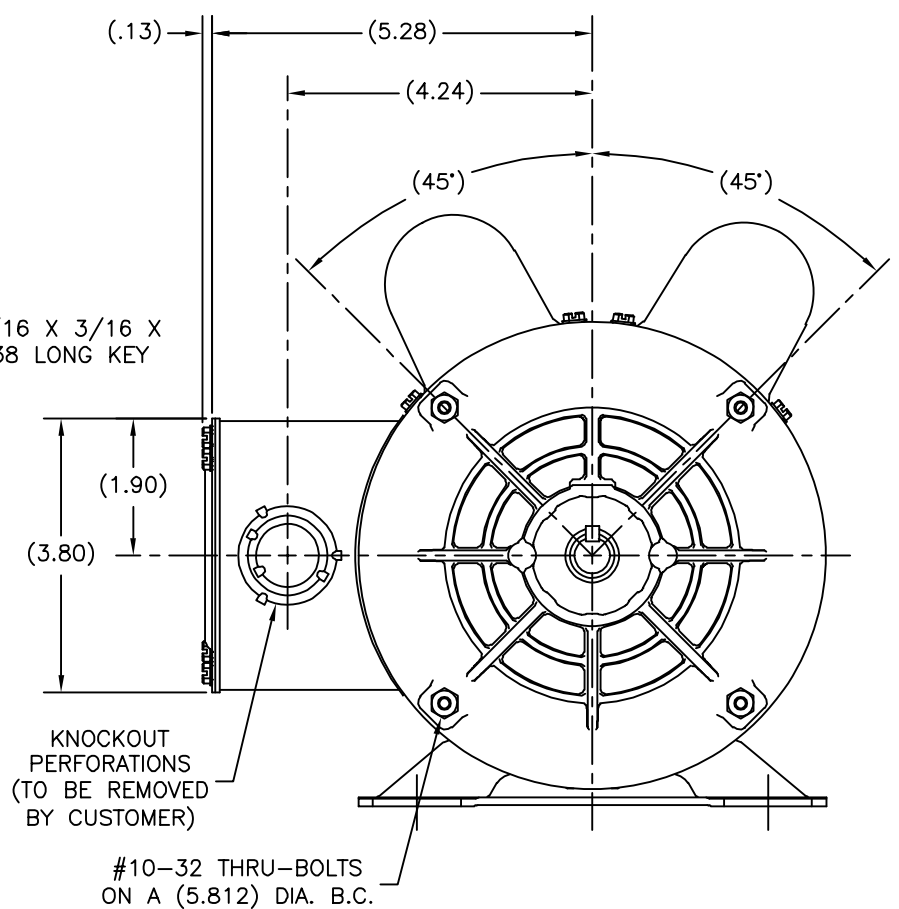
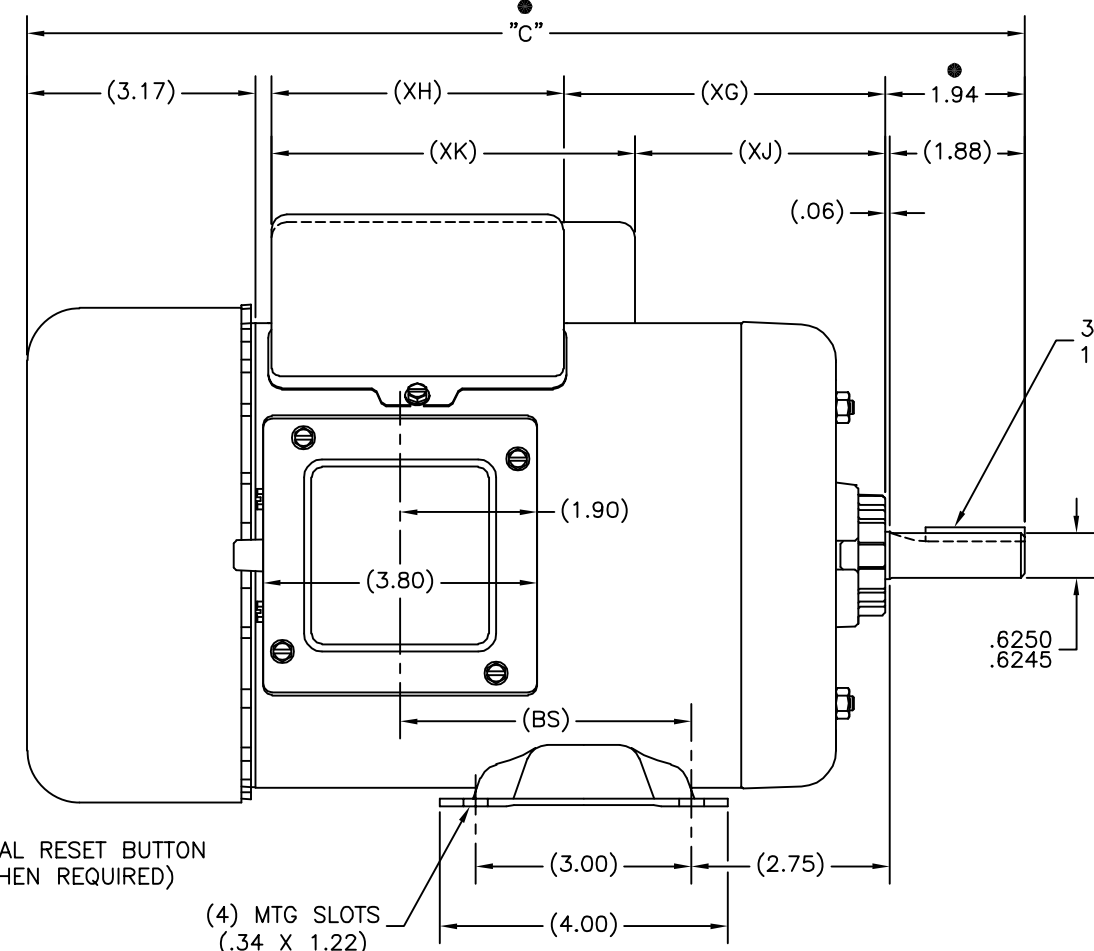
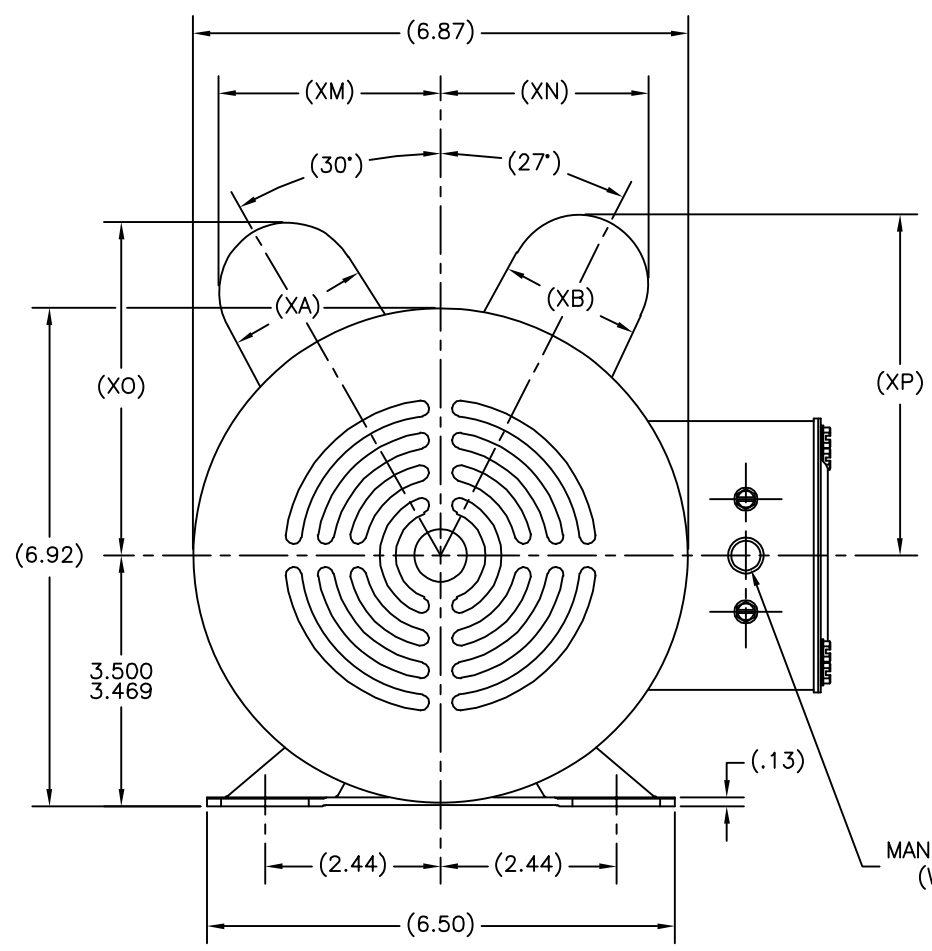

-03	CP	M56	13.86	4.05	2.01	2.01	3.47	5.06	3.47	5.06	3.09	2.89	4.63	4.74
-02	CSR	K56	12.61	2.80	2.01	2.01	3.22	4.06	3.22	4.06	3.09	2.89	4.63	4.74
-01	CSR	L56	13.36	3.55	2.01	2.01	3.97	4.06	3.97	4.06	3.09	2.89	4.63	4.74
GROUP	TYPE	FRAME	"C"	(BS)	(XA)	(XB)	(XG)	(XH)	(XJ)	(XK)	(XM)	(XN)	(XO)	(XP)

● = CRITICAL DIMENSION

形位公差	除另有注明
— 平面度	尺寸公差如下:
— 直线度	英寸 X XX XXX XXXX
— 倾斜度	英寸 ±.1 ±.02 ±.005 ±.0005
— 垂直度	毫米 ±0.5 ±0.13 ±0.013
— 平行度	清理毛刺和尖棱
— 圆度	英寸 .003-.015 毫米 0.1-0.4
— 圆柱度	内圆角
— 面轮廓度	英寸 .020 毫米 0.5
— 线轮廓度	表面粗糙度
— 圆跳动	英寸 125 毫米 3.2
— 位置度	米制尺寸显示在 []
— 同轴度	
— 对称度	

绘图: DAVHOL	12-14-1999
批准:	
第三角投影	图框格式发布日期 11-11-2011
	图框格式版本 G
机密: 本图纸及相关信息所有权归REGAL-BELOIT CORPORATION. 未经REGAL-BELOIT CORPORATION书面授权, 不得泄露、复制、传播或作其他用途。—版权所有	

名称	0056 DWG O-LINE BB TEFC RIGID BASE
图号	195077
比例	1=1
页号	1

REGAL-BELOIT CORPORATION