

Product Overview



Print



Product Type :	AC Motors
Product Family:	6-1/2" Diameter (56 Frame)
Stock Number:	B625
Reference:	Catalog Page: 208
Description:	MODEL-PFHP-56FR
Features:	Product feature information temporarily unavailable
Applications:	Product application information temporarily unavailable
List Price:	\$328

The image shown is representative only and the actual product may differ from the image shown

TECHNICAL SPECIFICATIONS NOTES DRAWINGS

Horse Power:	3/4
Amperes:	SF 6.4/12.8
Frequency:	60
RPM:	3450
Voltage:	230/115
Motor Type:	CS
Frame Size:	N56CZ
Nema Suffix:	CZ
Service Factor:	1.50
Phase:	1
Enclosure:	ODP
Bearings:	BALL BRG
Ambient Temperature:	40
Insulation Class:	B
Rotation:	CCWPE
Protector:	THERMALLY PROTECTED
Agency Approvals:	ULCSA
Duty Cycle:	CONT

GRP	D/S	TYPE	FRAME	C	BV	XA	XG	XH	XN	AH
01	4	CS	N56CZ	14.13	8.78	1.64	3.43	4.08	4.87	3.82
02	4	CS	S56CZ	13.26	7.91	1.64	3.06	4.08	4.87	3.82

REV	DATE	PROJECT	DESCRIPTION	REV BY	APPD
G	10/16/2003	00131101	added hex cap	margue	mguerr

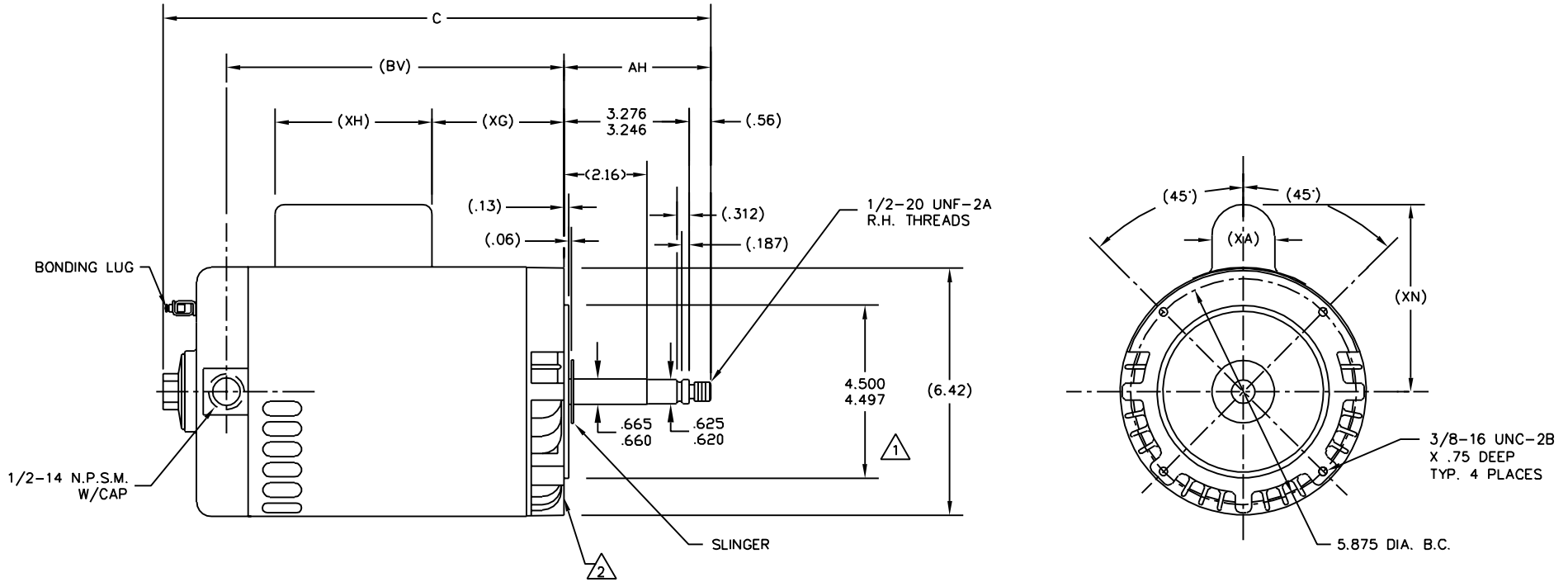

NOTES:

- 1 PILOT DIAMETER IS CONCENTRIC WITH SHAFT CENTERLINE WITHIN .004 T.I.R.
- 2 FACE OF MOUNTING FLANGE IS PERPENDICULAR TO SHAFT CENTERLINE WITHIN .004 T.I.R.
- 3 SHAFT RUNOUT NOT TO EXCEED .002 T.I.R.
- 4 FOR THREADED SHAFT EXT. MATING PARTS SHOULD BE RELIEVED ONE THREAD TO CLEAR FILLET
- 5 END PLAY NOT TO EXCEED .010 MEASURED WITH NO THRUST

C-CODE:	UNLESS OTHERWISE SPECIFIED DIM ARE IN INCHES	DR BY:	A. O. SMITH	
CLASS:	X = ± .1 XX = ± .02 XXX = ± .005 XXXX = ± .0005 AND	CK BY:	ELECTRICAL PRODUCTS COMPANY A DIVISION OF A. O. SMITH CORPORATION TYP 617, 9-10 COPYRIGHT 1995	
AUTOCAD FORM 3		APPD:	TITLE 0056 DWG O-LINE BB OP/EN	
CONFIDENTIAL DRAWING AND ITS INFORMATION ARE THE EXCLUSIVE AND CONFIDENTIAL PROPERTY OF A. O. SMITH CORP. AND ARE NOT TO BE DISCLOSED, DUPLICATED, DISTRIBUTED OR OTHERWISE USED WITHOUT THE WRITTEN CONSENT OF A. O. SMITH CORP. - ALL RIGHTS RESERVED.		ISS:	SIZE C DWG NO 183551	REV G
		THIRD ANGLE PROJECTION	SCALE 1=1	SHEET 1 OF 01