

PRODUCT INFORMATION PACKET



Model No: 435A
Catalog No: 435A

OEM Replacement Motor, 1/2 HP, 1 Ph, 60 Hz, 460 V, 1075 RPM, 1 Speed, 48 Frame, SEMI ENCLOSED



Regal and Century are trademarks of Regal Rexnord Corporation or one of its affiliated companies.
©2022 Regal Rexnord Corporation, All Rights Reserved. MC017097E





Nameplate Specifications

Output HP	1/2 Hp	Output KW	0.37 kW
Frequency	60 Hz	Voltage	460 V
Current	1.7 A	Speed	1075 rpm
Service Factor	1	Phase	1
Duty	Air Over	Insulation Class	B
Frame	48	Enclosure	Semi Enclosed
Thermal Protection	Automatic	Ambient Temperature	60 °C
UL	Recognized	CSA	Y
CE	N	Number of Speeds	1

Technical Specifications

Electrical Type	Permanent Split Capacitor	Starting Method	Across The Line
Poles	6	Rotation	Reversible
Mounting	Extended Studs	Motor Orientation	Vertical Shaft Up
Drive End Bearing	Ball	Opp Drive End Bearing	Ball
Frame Material	Rolled Steel	Shaft Type	Double Flat
Overall Length	11.60 in	Frame Length	4.50 in
Shaft Diameter	0.500 in	Shaft Extension	6.1 in
Connection Drawing	614131-242	Outline Drawing	435A-S01

This is an uncontrolled document once printed or downloaded and is subject to change without notice. Date Created:11/28/2022

GENERAL INFORMATION:

SHAFT RUNOUT: .001 [.025] T.I.R. PER INCH LENGTH OF EXTENSION

BEARINGS: BALL

MOUNTING POSITION: VERTICAL SHAFT UP

ELECTRICAL DATA:

OVERLOAD PROTECTOR: AUTOMATIC RESET (SENSATA 7AM 036)

LEADS: NO. 18 GA., .06 [1.5] THK. PVC 105°C INSUL.

REVERSING PLUGS: NO. 18 GA., .03 [.8] THK. XLP 125°C INSUL.

GROUND LEAD: NO. 18 GA., .03 [.8] THK. (GREEN/YELLOW) INSUL.

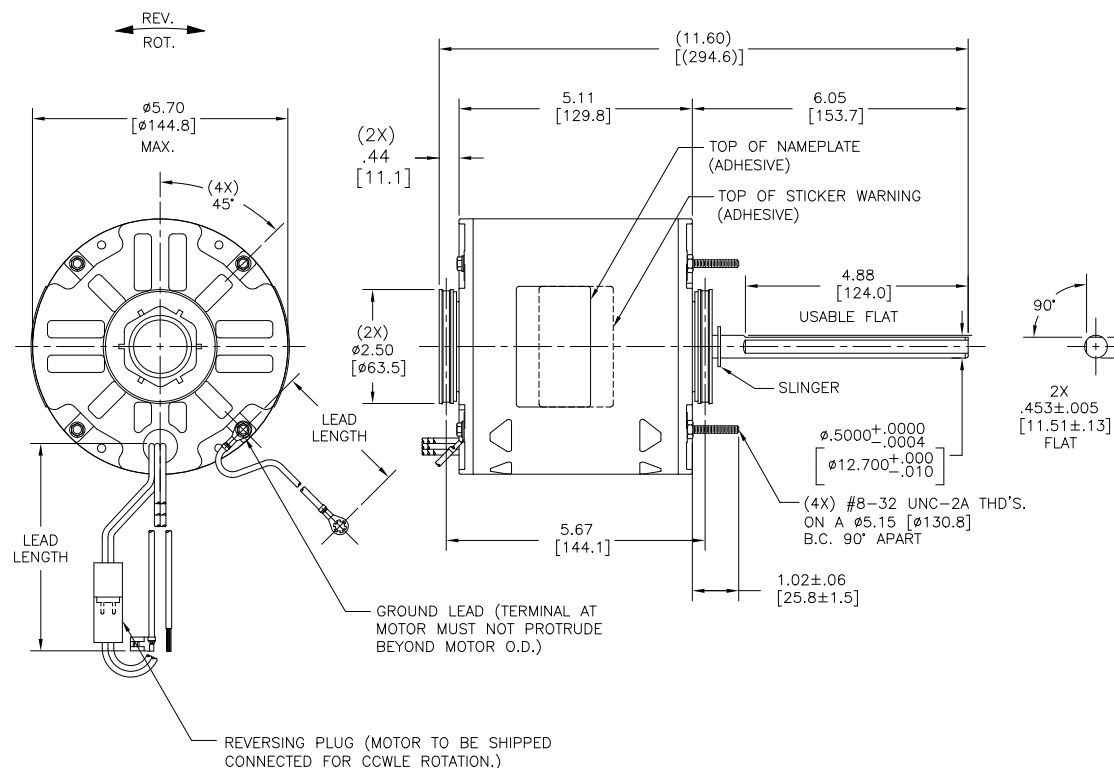

NAMEPLATE DATA:	EXTERNAL CONNECTION DIAGRAM
MODEL NO.: F48Y46A01 CUST. P/N: 435A HP: 1/2 ROT.: REVERSIBLE RPM: 1075 TYPE: UF FRAME: 48 VOLTS: 460 PH: 1 AMPS: 1.7 HZ: 60 INS.: B AMB.: 60° C DUTY: AIR OVER CAP.: 7.5 MFD/370 V ENCL.: SEMI-ENCL. UL LOGO CSA LOGO THERMALLY PROTECTED	
614131-242	

COLOR	LENGTH	TERMINAL OR STRIP LENGTH
GREEN/YELLOW (GROUND)	11.0/13.0 [279/330]	#10 EYELET
BLACK/WHITE	3.0/5.0 [76/127]	REVERSING PLUG
BROWN	19.0/21.0 [483/533]	.25 [6.4] FLAG
BROWN/WHITE	19.0/21.0 [483/533]	.25 [6.4] FLAG
WHITE	19.0/21.0 [483/533]	.50 [12.7] SKIN
BLACK	19.0/21.0 [483/533]	.50 [12.7] SKIN
COLOR	LENGTH	TERMINAL OR STRIP LENGTH

REGAL-BELOIT CORPORATION (RBC) PROVIDES TECHNICAL ASSISTANCE TO OUR CUSTOMERS IN SEVERAL AREAS. SINCE RBC DOES NOT RECEIVE ALL DATA CONCERNING THE USE AND APPLICATION OF THE MOTOR, THE SUITABILITY OF THE MOTOR FOR THE APPLICATION MUST BE DETERMINED BY THE CUSTOMER.

DIMENSIONS WITHOUT TOLERANCES ARE FOR REFERENCE ONLY.

MAIN FRAME - OLE	SEMI-ENCL.
END FRAME - OLE	ENCLOSED
MAIN FRAME - LE	SEMI-ENCL.
END FRAME - LE	OPEN

PERFORMANCE CURVE NO.	TORQUE @ 1075 RPM (25°C)	APPROVED SAMPLE	UL COMPONENT				CSA	
			FILE #	CCN #	FILE #	CLASS #		
C32660	47.7 OZ. FT.	0600679B	E46412	PRGY2	LR43341	4211-01		

DRAWING REVISION	REVISION BY	DATE
C	J. RUPERT	07-12-2021
ECO	APPROVED BY	DATE
NMR-0209481	J. RUPERT	07-12-2021

ECO DESCRIPTION
REVISED FOR UP ISSUE

COPYRIGHT REGAL-BELOIT AMERICA, INC. ALL RIGHTS RESERVED. PROPRIETARY AND CONFIDENTIAL INFORMATION - THIS DOCUMENT IS THE PROPERTY OF REGAL-BELOIT AMERICA, INC. (OWNER) AND CONTAINS OWNER'S PROPRIETARY INFORMATION. ANY PERSON, CORPORATION OR OTHER ENTITY, DUPLICATING AND/OR USING, BY RECEIVING IT, TO AGREE THAT IT, AND/OR ANY PART OF IT, SHALL NOT BE DISCLOSED TO ANY PERSON, CORPORATION OR OTHER ENTITY, DUPLICATED, AND/OR USED, EXCEPT AS EXPRESSLY APPROVED IN WRITING IN ADVANCE BY OWNER. THIS DOCUMENT SHALL BE RETURNED TO OWNER UPON REQUEST. IT MAY BE SUBJECT TO CERTAIN RESTRICTIONS UNDER APPLICABLE EXPORT CONTROL LAWS AND REGULATIONS.

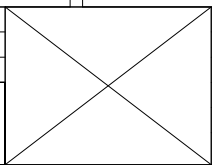

DRAWN BY:	J. RUPERT
DATE:	04-26-2011
APPROVED BY:	J. RUPERT
DATE:	04-26-2011
REFERENCE	
THIRD ANGLE PROJECTION	

REGAL ™ Regal Beloit America, Inc.	
DESCRIPTION	MODEL-RFHP-48FR OUTLINE
MATERIAL	PROCESS/FINISH
SIZE	DWG NO
C	435A
SHEET	1



NOTES:

1. FOR USE WITH 614129 NAMEPLATE BLANK
2. — — — — — INDICATES DIMENSION LIMITS
3. DIE TO BE MADE FROM MASTER SUPPLIED BY REGAL REXNORD CORPORATION
4. DIE MUST PRODUCE A LEGIBLE IMPRESSION.

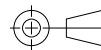
DRAWING REVISION H		REVISION BY J. RUPERT	DATE 03-16-2022	TOLERANCES UNLESS OTHERWISE SPECIFIED DEC. INCH mm ANGLE .X ±0.1 [±2.5] ±0.5° .XX ±0.02 [±0.51] .XXX ±0.005 [±0.127] .XXXX ±0.0005 [±0.0127] REMOVE BURRS & BREAK SHARP EDGES .003/.015 [0.076/.381] X 45° CORNER FILLETS R.02 [.51] MACHINED SURFACES INCH 125/mm 3.2 mm SHOWN IN [BRACKETS]	DRAWN BY: YL	 Regal Beloit America, Inc.
ECO NMR-0213140		APPROVED BY J. RUPERT	DATE 03-16-2022		DATE: 04-15-2011	
ECO DESCRIPTION REVISED FOR UP ISSUED					APPROVED BY: HZ	DESCRIPTION CONNECTION DIAGRAM EXTERNAL
<small>COPYRIGHT REGAL BELOIT AMERICA, INC. ALL RIGHTS RESERVED. PROPRIETARY AND CONFIDENTIAL INFORMATION - THIS DOCUMENT IS THE PROPERTY OF REGAL BELOIT AMERICA, INC. ("OWNER") AND CONTAINS OWNER'S PROPRIETARY INFORMATION. ANY PERSON, CORPORATION OR OTHER FIRM RECEIVING IT IS DEEMED, BY RECEIVING IT, TO AGREE THAT IT, AND/OR ANY PART OF IT, SHALL NOT BE DISCLOSED TO ANY PERSON, CORPORATION OR OTHER ENTITY, DUPLICATED, AND/OR USED, EXCEPT AS EXPRESSLY APPROVED IN WRITING IN ADVANCE BY OWNER. THIS DOCUMENT SHALL BE RETURNED TO OWNER UPON REQUEST. IT MAY BE SUBJECT TO CERTAIN RESTRICTIONS UNDER APPLICABLE EXPORT CONTROL LAWS AND REGULATIONS.</small>					DATE: 04-15-2011	
				REFERENCE	MATERIAL	PROCESS/FINISH
				THIRD ANGLE PROJECTION 	SIZE DWG NO A 4 of 4	SHEET 1
					614131-242	