

# Circuit Board Replacement Kit For FA4A, FB4A, FC4B 40YR, 40YA, 617A, 618A Fan Coils

Cancels: IIK FA4A-18-3

IIK FA4A-18-5  
9-03

## Installation Instruction 322848-751

**NOTE:** Read the entire instruction manual before starting the installation.

### SAFETY CONSIDERATIONS

Improper installation, adjustment, alteration, service, maintenance, or use can cause explosion, fire, electrical shock, or other conditions which may cause personal injury or property damage. Consult a qualified installer, service agency, or your distributor or branch for information or assistance. The qualified installer or agency must use factory authorized kits or accessories when modifying this product. Refer to the individual instructions packaged with the kits or accessories when installing.

Follow all safety codes. Wear safety glasses and work gloves. Use quenching cloth for brazing operations. Have fire extinguisher available. Read these instructions thoroughly and follow all warning or cautions attached to the unit. Consult local building codes and National Electrical Code (NEC) for special requirements.

Recognize safety information. This is the safety-alert symbol . When you see this symbol on the unit and in instructions or manuals, be alert to the potential for personal injury.

Understand the signal words DANGER, WARNING, and CAUTION. These words are used with the safety-alert symbol. DANGER identifies the most serious hazards which **will** result in severe personal injury or death. WARNING signifies hazards which **could** result in personal injury or death. CAUTION is used to identify unsafe practices which **would** result in minor personal injury or product and property damage.

### INTRODUCTION

Kit 322848-751 replaces Texas Instruments (TI) printed circuit boards HK61GA001 and HK61GA003 used on fan coil models FA4A, FB4A, FC4B, 40YR, 40YA, 617A, and 618A produced before April 1994. Kit can be applied to all sizes of these fan coils. Replacement kit comes assembled with circuit board fastened to low voltage barrier and wiring harness connected to circuit board. The contents of kit are listed in Table 1.

Table 1-Kit Contents

PART NO.	DESCRIPTION	QUANTITY
HK61EA002	Printed Circuit Board	1
321702-401	Low Voltage Barrier	1
322847-3R11	Wiring Harness	1
HY89TB016	Crimp Wire Nut	3
321214-101	Wiring Label	1

### WARNING

Before installation or servicing system, always turn off main power to system. There may be more than 1 disconnect switch. Turn off accessory heater power if applicable. Electrical shock can cause personal injury or death.

### INSTALLATION

#### Step 1—Check Equipment

Compare the contents of the kit with Table 1.

#### Step 2—Remove Blower Panel to Access Box with Printed Circuit Board, Remove Control Wiring

After disconnecting all power, remove blower access panel. Completely disconnect printed circuit board wiring including leads to transformer and 12-pin Molex plug.

#### Step 3—Remove Texas Instruments Circuit Board and Low Voltage Barrier and Replace with Kit Circuit Board Assembly.

1. Remove 2 screws holding sheet metal low voltage barrier to fan coil casing. Do not discard screws.
2. Remove TI assembly by pulling up on 2 tabs at base of circuit board. Discard assembly.
3. Install kit circuit board assembly placing 2 tabs on sheet metal low voltage barrier into slots on blower deck where TI circuit board was removed.
4. Use 2 screws to attach low voltage barrier to fan coil casing in locations where screws were removed.

#### Step 4—Connect Both Low Voltage and High Voltage Wires From Transformer to Circuit Board and Harness

Transformer used with TI circuit board had terminated leads for both low and high voltage connections. Current fan coil harness is designed for transformers with leads on low voltage and 3 high voltage 208/230v connections at transformer using 3/16-in. spade connectors. Yellow lead (common) from Molex plug and black lead (208/230v) from relay on circuit board in kit are stripped for crimp wire nut connections.

1. Locate leads (3) from transformer for high voltage connections and cut off terminations to strip ends 1/2 in.
2. Locate yellow lead (common) from blower motor and cut off termination to strip end 1/2 in.
3. Tie 2 yellow leads (common) to black lead (common) of transformer with crimp wire nut provided. Secure wire nut. (See Fig. 1.)
4. Connect blue wire of transformer for 208v or red wire of transformer for 230v to black wire with stripped end coming from relay of circuit board, and secure with crimp wire nut provided. (See Fig. 1.)

Manufacturer reserves the right to discontinue, or change at any time, specifications or designs without notice and without incurring obligations.

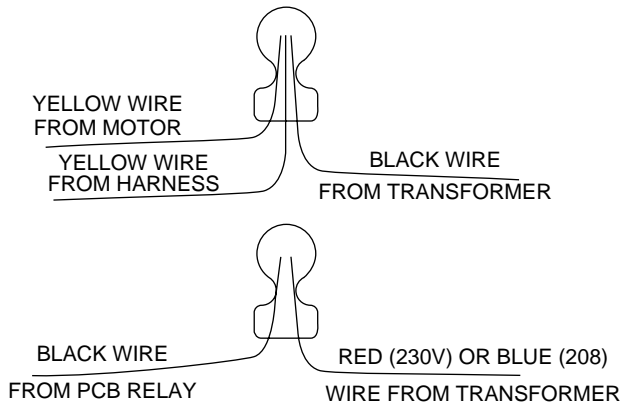

**Fig. 1—High Voltage Connections**

A98509

5. Terminate unused lead from transformer with third crimp wire nut provided.
6. Connect 24v red wire of transformer to 1/4 in. spade terminal on circuit board marked T. (See Fig. 2.)
7. Connect 24v brown wire of transformer to 1/4-in. spade terminal piggybacked terminal on circuit board marked C (common). (See Fig. 2.)

**Step 5—Install Blower Lead Terminal onto Relay for Desired Speed Tap**

1. Locate desired speed tap lead: black for high speed, blue for medium speed, red for low speed.
2. Insert insulated 1/4-in. female terminal into spade terminal of fan relay on circuit board. (See Fig. 2.)
3. Insulate remaining 2 tap lead terminals to prevent contact with any metal in area.

**Step 6—Connect Molex Plug of Wiring Harness**

1. Connect Molex plug to female end of wiring harness that routes to circuit board.
2. Secure loose wires with wire ties.

**Step 7—Install Wiring Label**

1. Install wiring label provided in kit onto blower housing.

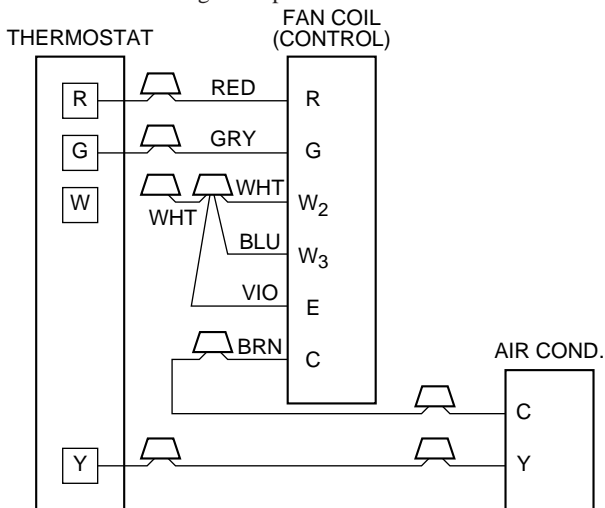

A94058

**Fig. 3—Wiring Layout Air Conditioning Unit (Cooling Only)**

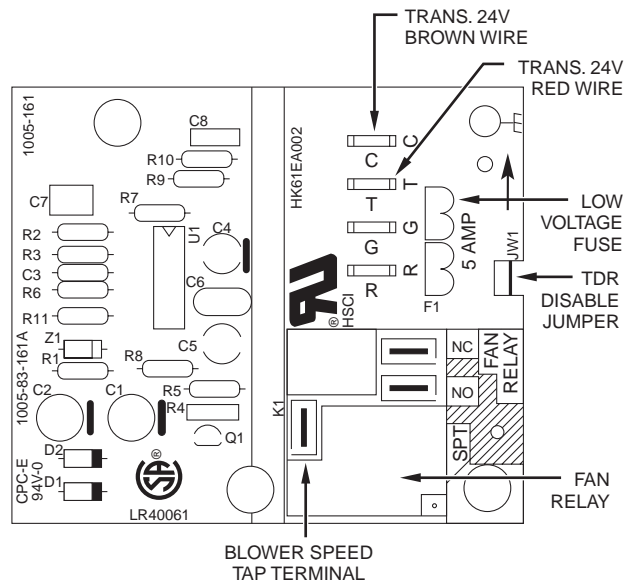

A03160

**Fig. 2—Fan Coil Printed Circuit Board**

**Step 8—Make System Thermostat Connections**

Make thermostat connections to indoor unit, outdoor unit, and thermostat system according to wiring diagram on blower wrapper. (See Figs. 3, 4, 5, 6, and 7.) Red wire (R) for 24v. White wire (W) for heating. Gray wire (G) for fan operation. Brown wire (C) for common. Secure all connections with wire nuts (not provided).

**NOTE:** Circuit board has built-in 90 sec blower off delay that allows blower to remain energized after G signal (fan) goes away. For immediate shut off after cooling call, cut jumper wire JW1 on circuit board. (See Fig. 2.)

**Step 9—Accessories Installation**

1. Electronic Air Cleaner

The Electronic Air Cleaner may be connected to fan coil as shown in Fig. 8. This method requires a field-supplied 240v/120v 40va transformer because it uses the 230v fan coil power supply. Consult electronic air cleaner literature for kit requirements.

2. Humidifier

Connect humidifier and humidistat to fan coil unit as shown in Fig. 9 and Fig. 10. The cooling lockout relay is optional (See Fig. 11.)

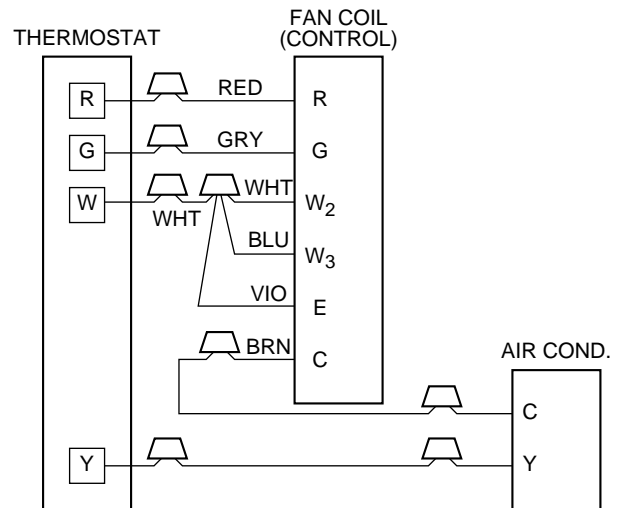

A94059

**Fig. 4—Wiring Layout Air Conditioning Unit (Cooling and 1-Stage Heat)**

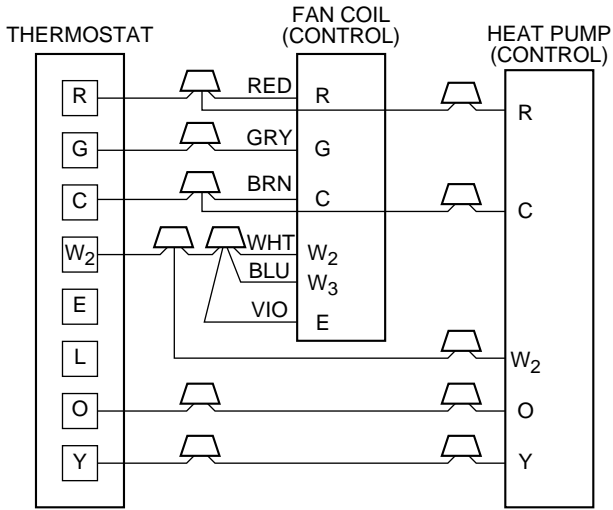

A94060

**Fig. 5—Wiring Layout Heat Pump  
(Cooling and 2-Stage Heat with  
No Outdoor Thermostat)**

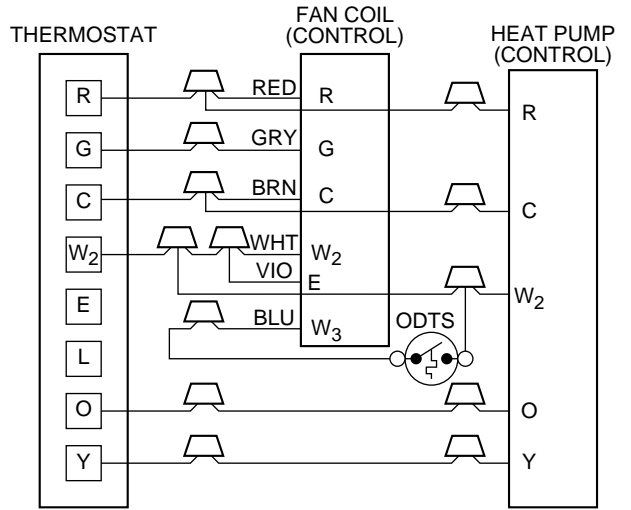

A94061

**Fig. 6—Wiring Layout Heat Pump  
(Cooling and 2-Stage Heat with  
1 Outdoor Thermostat)**

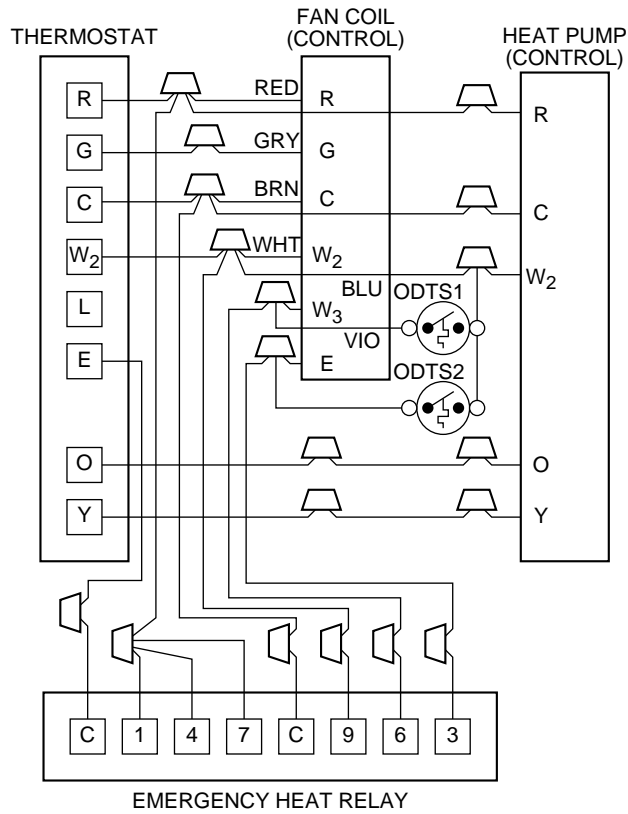

A94062

**Fig. 7—Wiring Layout Heat Pump  
(Cooling and 2-Stage Heat with 2 Outdoor Thermostats)**

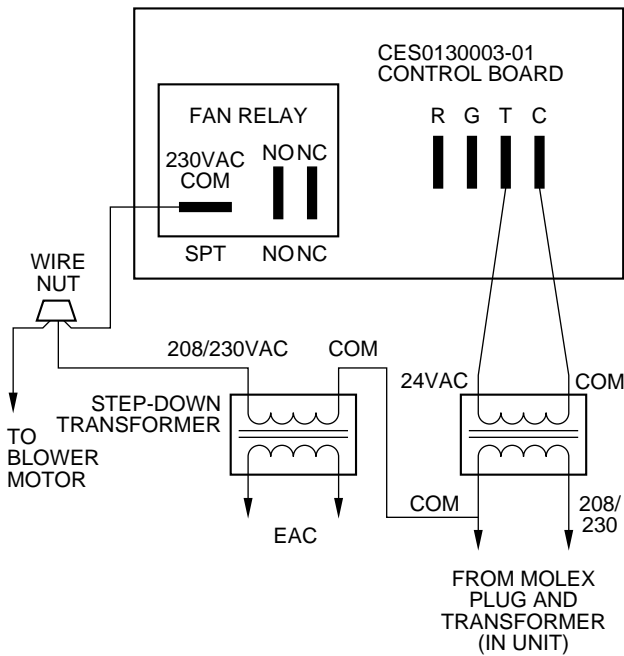

**Fig. 8—Wiring Layout of Electronic Air Cleaner to Fan Coil**

A98236

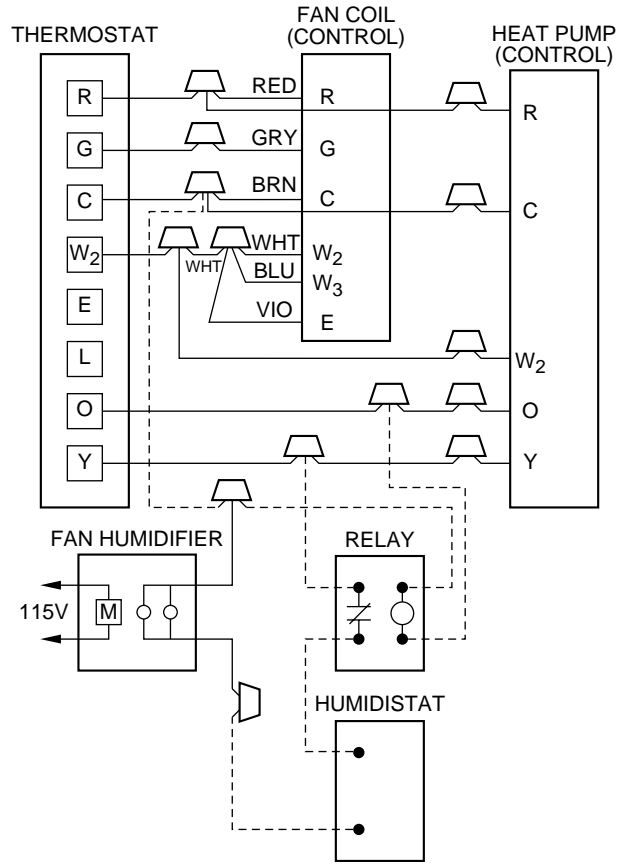

**Fig. 9—Wiring Layout of Humidifier to Heat Pump**

A95294

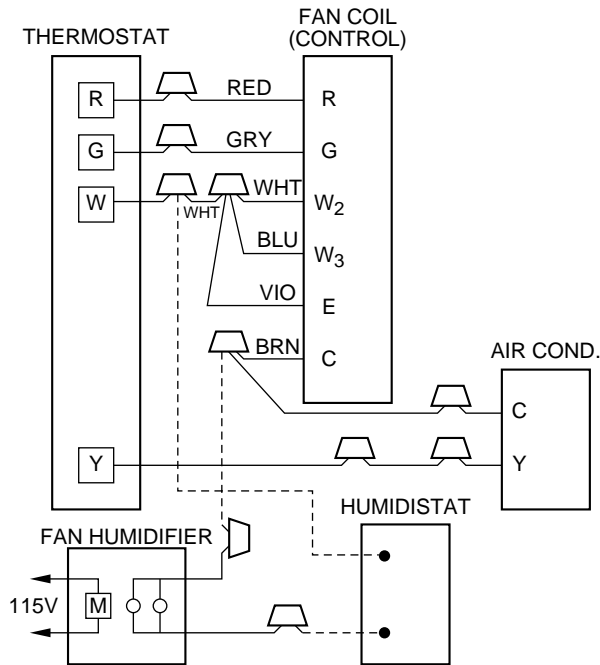

**Fig. 10—Wiring Layout of Humidifier to Fan Coil with Electric Heat**

A95295

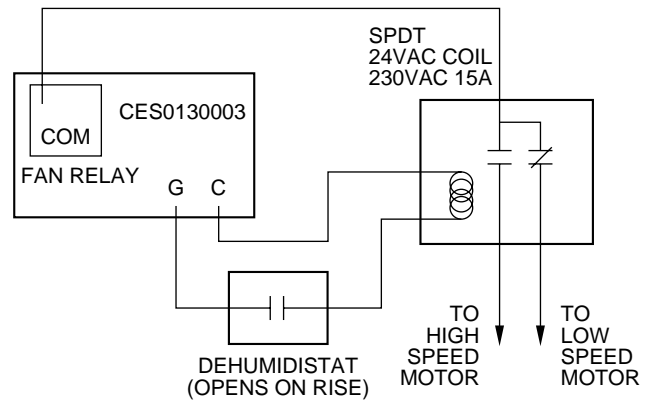

**Fig. 11—Latent Capacity Control**

A95296