



FRONT VIEW



EXPLOSION PROOF STANDARD WALL EXHAUST FANS

Efficient, low maintenance and easy to install.

Canarm LFI's explosion proof fans follow a tradition of quality in design, materials and construction. Using our quality "Standard Fan" housing and motor mount as the basis for design, we have developed an efficient, economically priced Explosion Proof Fan. All Explosion Proof Fans have a single speed, dual voltage explosion proof motor that meets and conforms to all the standards that are listed below.

- CLASS I, GROUP C** Atmospheres containing ethyl ether, ethylene, gases or vapors of equivalent hazard.
- CLASS I, GROUP D** Atmospheres such as acetone, ammonia, benzene, butane, cyclopropane, ethanol, gasoline, hexane, methane, natural gas, naphtha, propane, or gasses or vapors of equivalent hazard.
- CLASS II GROUP F** Atmospheres containing carbonaceous dust, including carbon black, charcoal, coal, or coke dusts that have more than 8% total entrapped volatiles, or dusts that have been sensitized by other materials so that they present an explosion hazard.
- CLASS II GROUP G** Atmospheres containing combustible dusts not included in group E or F, including flour, grain, wood, plastic and chemicals.

FEATURES

- Totally enclosed, ball bearing motor with thermal overload protection.
- The fan blades are well-balanced, heavy gauge aluminum.
- The rugged steel welded box housing has a durable powder coated finish.
- Aluminum louver shutters are supported by long life nylon bushings.
- Heavy wire chrome plated OSHA guards on intake side of fan.
- All fans are shipped completely assembled.

DIMENSIONS

FAN SIZE	A X A SQUARE	B	C	D c/c	E	N
8"	13 1/4"	17 1/2"	4"	12"	10 3/4"	2
10"	15 1/4"	17 1/2"	4"	14"	12 3/4"	2
12"	17 1/4"	20 1/2"	6"	16"	14 3/4"	3
18"	23 1/4"	20 1/2"	6"	22"	20 3/4"	4
24"	29 1/4"	20 1/2"	6"	28"	26 3/4"	5

SPECIFICATIONS



MODEL	FAN SIZE	HP	VOLTS	AMPS	SPEED	RPM	AIRFLOW CAPACITY - CFM				FRAMING DIMENSIONS	WEIGHT (LBS)
							0" SP	.05" SP	.10" SP	.25" SP		
SD08-XPF	8"	1/3	115/230	6.6/3.3	Single	1625	320	280	240	-	11" X 11"	38
SD10-XPF	10"	1/3	115/230	6.6/3.3	Single	1625	620	575	530	-	13" X 13"	39
SD12-XPF	12"	1/3	115/230	6.6/3.3	Single	1625	1,640	1,600	1,540	1,390	15" x 15"	42
SD18-XPF	18"	1/3	115/230	6.6/3.3	Single	1625	3,200	3,150	3,090	2,920	21" x 21"	60
SD24-XPF	24"	1/3	115/230	6.6/3.3	Single	1625	5,500	5,400	5,310	5,100	27" x 27"	72

NOTE: RPM Min (Minimum) is determined when louvers are opened one inch.
Note: Wind has a significant effect on exhaust fans. A 10 mph wind creates a 0.05" pressure against the fan. A 20 mph wind creates 0.20" pressure and 30 mph a 0.45" pressure. These pressures are in addition to the static pressure in the building. Wind blocks or hoods should be included in all designs where fans will be subjected to winds above 10 mph.

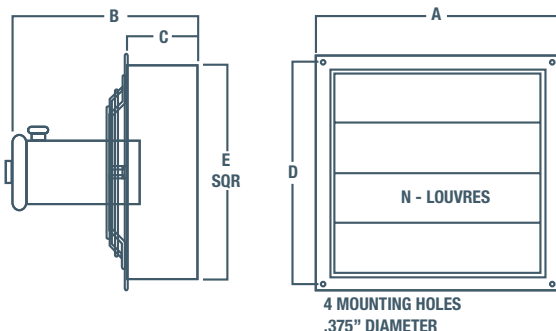

BACK VIEW

ACCESSORIES

- Hoods

For a complete listing of all available hoods, see page D11.