

Now Available with EC motors!
See Green Products for more info

SD - STANDARD WALL EXHAUST FANS

Efficient, low maintenance and easy to install.



Canarm/LFI's standard fans follow a tradition of quality in design, materials and construction. All our standard fans are developed to be efficient and economically priced. Fans are available in single, two and variable speed models. All variable speed standard fans use an energy efficient variable speed, dual voltage motor and blade combination. To determine the proper Canarm/LFI fan for your applications, use the formula and table shown on back of page.

FEATURES

8" & 10" Models

- Smooth, quiet, reliable, maintenance-free operation
- Durable steel construction with grey powder coat finish
- 2 speed fan with high efficiency Euro design external rotor motor
 - Totally enclosed with sealed ball bearings
 - Pull chain speed control
 - 9 foot cord with 115 volt, 3-prong plug
- Swept back, high efficiency, low noise blade design
- Quiet, aluminum shutters with tie bar to maximize airflow and a magnet to prevent flapping and provide a superior seal
- Zinc plated OSHA guard
- Fans shipped completely assembled
- Easy to install! Mount fan using four screws, plug it in and turn it on



12" to 48" Models

- Single, two and variable speed models are available.
- All fans use a totally enclosed, thermally protected motor.
- Rugged steel welded box housing has a durable powder coated finish.
- Aluminum louver shutters are supported by long life nylon bushings (30", 36", 42" & 48" have aluminum louvers).
- 12" - 24" models have heavy wire chrome plated OSHA guards on intake side of fan. 30", 36", 42" & 48" models have grey powder coated guards.
- All fans are shipped completely assembled.

8" - 24" sizes: Now upgraded with tie bar shutters and magnets for quieter operation and superior seal!

SPECIFICATIONS

MODEL	SPEED	BLADE DIAMETER	RPM	HP	VOLTAGE	AMPS (FLA)	WEIGHT (LBS)	dB(A) @5 ft	CFM @ STATIC PRESSURE				FRAMING DIMENSIONS											
									0.00"	0.10"	0.125"	0.25"												
SD08	Two	8"	1600/1300	25W	115	0.2	13	48	360/292	270/150	230/110	--	11" X 11"											
SD10	Two	10"	1480/1150	60W	115	0.5	15	55	500/388	420/300	400/250	--	13" X 13"											
S12-E1	Single	12"	1625	1/4	115	2.7	28	63	1640	1540	1510	1390	15" X 15"											
S12-E2	Two	12"	1725/1140	1/4	115	3.4	32	64	1650/1090	1550/950	1520/930	1390/0	15" X 15"											
S12-EVD	Variable	12"	1625	1/3	115/230	5.0/2.5	32	60	1650	1540	1510	1390	15" X 15"											
S14-E1	Single	14"	1625	1/4	115	2.7	30	67	2170	2070	2030	1860	17" X 17"											
S14-E2	Two	14"	1725/1140	1/4	115	3.4	34	65	2180/1350	2080/1190	2060/1160	1890/0	17" X 17"											
S16-E1	Single	16"	1625	1/4	115	2.7	33	68	2370	2270	2210	2060	19" X 19"											
S16-E2	Two	16"	1725/1140	1/4	115	3.4	36	69	2380/1640	2280/1490	2230/1430	2070/0	19" X 19"											
S16-EVD	Variable	16"	1625	1/3	115/230	5.0/2.5	36	63	2370	2270	2210	2063	19" X 19"											
S18-F1	Single	18"	1625	1/3	115	4.1	37	73	3200	3090	3040	2920	21" X 21"											
S18-F2	Two	18"	1725/1140	1/3	115	5.5/2.9	43	74	3200/2100	3090/1890	3040/1820	2920/0	21" X 21"											
S18-FVD	Variable	18"	1625	1/3	115/230	3.8/1.9	45	74	3150	3050	2980	2860	21" X 21"											
S20-F1	Single	20"	1625	1/3	115	4.1	41	77	3420	3220	3170	2920	23" X 23"											
S20-F2	Two	20"	1725/1140	1/3	115	5.5/2.9	45	77	3440/2300	3240/2000	3180/1950	2930/0	23" X 23"											
SD24-F1	Single	24"	1100	1/3	115	3.6	46	70	5000	4500	4300	3600	27" X 27"											
SD24-GVD	Variable	24"	1075	1/3	115/230	4.4/2.2	56	72	5050	4910	4810	4400	27" X 27"											
SD30-G1D	Single	30"	1075	1/3	115/230	4.4/2.2	72	82	8000	7000	6000	5000	33" X 33"											
SD36-G1D	Single	36"	850	1/2	115/230	6.6/3.3	88	72	10000	8500	8000	6200	39" X 39"											
SD42-H1D	Single	42"	850	1	230	5	122	83	BHP	FEI	BHP	FEI	BHP	FEI	BHP	FEI	45" X 45"							
									0.85	1.35	0.87	1.45	0.87	1.45	0.92	1.41								
									12860				11580				11090				9029			
SD48-H1D	Single	48"	850	1	230	5	140	84	BHP	FEI	BHP	FEI	BHP	FEI	BHP	FEI	51" X 51"							
									0.82	1.56	0.84	1.67	0.84	1.69	0.83	1.48								
									14470				12610				12200				8400			

RPM Minimum is determined when louvers are opened one inch. Some models are available with explosion proof motors. Please see SD-XPF.

Note: Wind has a significant effect on exhaust fans. A 10 mph wind creates a 0.05" pressure against the fan. A 20 mph wind creates 0.20" pressure and 30 mph a 0.45" pressure. These pressures are in addition to the static pressure in the building. Wind blocks or hoods should be included in all designs where fans will be subjected to winds above 10 mph.

AIR CHANGES PER MINUTE

To determine the proper Canarm/LFI fan for your applications, use the following formula.
Number of cubic feet in room / Number of minutes per air change = Required C.F.M. Capacity

EXAMPLE: A general office, (see chart) which requires an air change every ten minutes, would require the following fan capacity.
If office is 100' x 40' x 10' = 40,000 cubic ft; 40,000 cubic ft / 10 minutes per air change = 4000 Required C.F.M.

From the chart, you would select a fan that is rated at 4000 C.F.M. at 1/8" S.P. (Static Pressure)

Application	Minutes per Air Change	Application	Minutes per Air Change	Application	Minutes per Air Change	Application	Minutes per Air Change
Assembly Hall	7	Church	15	Foundry	4	Pressing Room	1
Attic	2	Classroom	6	Garage	5	Projection Booth	2
Auditorium	10	Dance Hall	5	General Office	10	Summer Cooling	1
Barber Shop	6	Department Store	6	Gymnasium	8	Toilet	3
Basement	8	Dry Cleaning	5	Laundry	2	Transformer Room	1
Battery Room	4	Engine Room	6	Locker Room	3	Warehouse	12
Boiler Room	1	Factory	6	Machine Shop	8	Welding Shop	2
Bowling Alley	5	Forge Room	3	Plating Room	3		

DIMENSIONS

8" & 10" Models

FAN SIZE	A	B	C	D (c/c)	E SQR	N
8"	13 1/4"	7 9/16"	4"	12"	10 3/4"	2
10"	15 1/4"	7 7/8"	4"	14"	12 3/4"	3

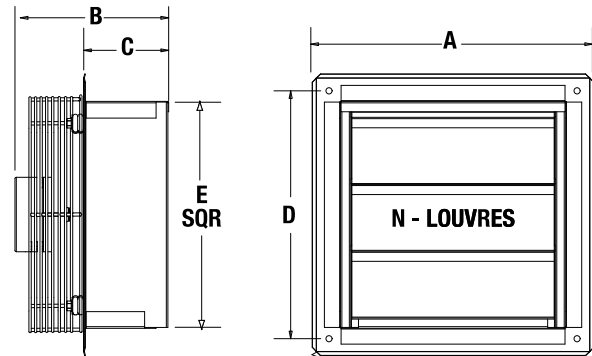

12" to 48" Models

FAN SIZE	A X A SQUARE	B	C	D (c/c)	E	N
12"	17 1/4"	17"	6"	16"	14 3/4"	3
14"	19 1/4"	17"	6"	18"	16 3/4"	3
16"	21 1/4"	17"	6"	20"	18 3/4"	4
18"	23 1/4"	18"	6"	22"	20 3/4"	4
20"	25 1/4"	18"	6 3/4"	24"	22 3/4"	5
24"	29 1/4"	18"	6 3/4"	28"	26 3/4"	5
30"	35 1/4"	18"	6"	34"	32 3/4"	16
36"	41 1/4"	18"	6"	40"	38 3/4"	20
NEW 42"	47 1/4"	18"	6 3/4"	46"	44 3/4"	24
NEW 48"	53 1/4"	19"	6 3/4"	52"	50 5/8"	26

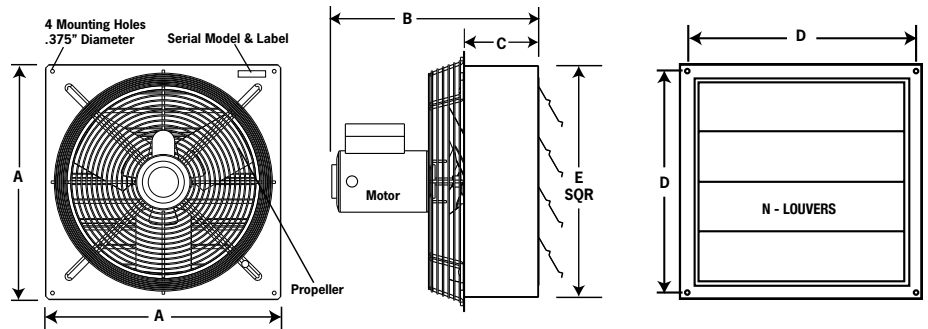

ACCESSORIES

- Grey plastic weather hood
- Galvanized metal hood
- MC type & wet locations controls.

For a complete listing on all available accessories, see page D17.
 For a complete listing of all available hoods, see page D11.
 For all available control options, see Controls & Thermostats tab.