

GSQ-D SERIES

Backward Inclined Direct Drive Square Inline Blowers

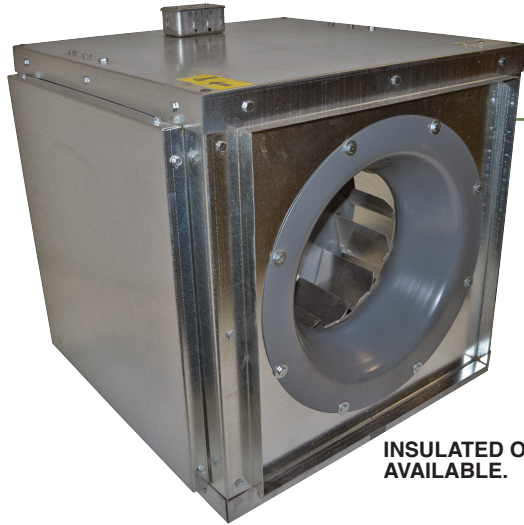

INSULATED OPTIONS AVAILABLE.

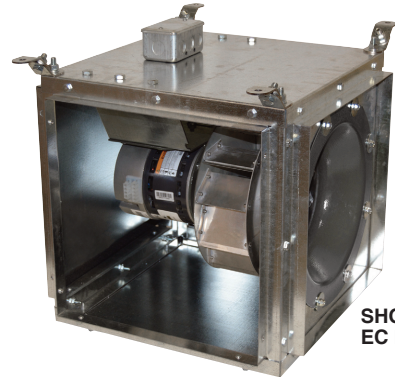

SHOWN WITH EC MOTOR

FEATURES

- Available in 9" to 18".
- High efficiency aluminum wheel.
- Side discharge option as standard - simply re-locate the side panel to the discharge.
- Bottom discharge available with flange kit.
- Junction box.
- GSQ-D-V with PSC variable speed motor.
- High Efficiency EC variable speed motor available.
- All standard single phase motor are single speed.
- All 3 phase motors are VFD compatible.
- Consult factory for different motor options.
- Multiple Mounting options.

PERFORMANCE SPECIFICATIONS

TYPICAL MAXIMUM CFM @ SP							
MODEL	1/4" SP	1/2" SP	3/4" SP	1" SP	1 1/4" SP	1 1/2" SP	HP
GSQ090-D-V*	425	325	175	--	--	--	1/4
GSQ105-D-V *	1150	1000	825	550	--	--	1/2
GSQ120-D-V*	1725	1575	1425	1200	1025	500	1/2
GSQ135-D-V*	2575	2400	2250	2000	1850	1400	3/4
GSQ150-D-EC	3300	3100	2825	2450	2200	1900	1
GSQ165-D-EC	3750	3350	2950	2550	2250	1900	1
GSQ180-D-EC	4200	3650	3250	2550	--	--	1

*Also available with EC motor. See Green Series.

Power rating (BHP) does not include transmission losses. Performance certified is for installation type B - Free inlet, Ducted Outlet. Performance ratings do not include the effects of appurtenances (accessories).

CFM values listed above are summarized for convenience.

FOR FAN CURVES & FULL PERFORMANCE DATA, CONSULT OUR DELAIR SOFTWARE.
 DOWNLOAD DELAIR @ WWW.CANARM.COM/DELAIR

DIMENSIONS

GSQ-D DIRECT DRIVE BACKWARD INCLINED SQUARE INLINE BLOWER					
MODEL	A	B	A1	B1	H
GSQ090-D	15 5/64"	11 5/64"	18 37/64	11	15 7/16"
GSQ105-D	17 1/8"	14 5/8"	21 1/2"	15 3/8"	18 15/16"
GSQ120-D	20"	17"	24 3/8"	17 3/4"	21 13/16"
GSQ135-D	22"	18 3/4"	26 3/8"	19 1/2"	23 13/16"
GSQ150-D	24 1/2"	20 7/8"	38 3/8"	21 5/8"	26 5/16"
GSQ165-D	26 3/4"	23"	31 1/8"	23 3/4"	28 9/16"
GSQ180-D	29 5/8"	25 3/8"	34"	26 1/8"	31 7/16"

Mounting brackets shown in both positions.
 Can be top or bottom mounted.

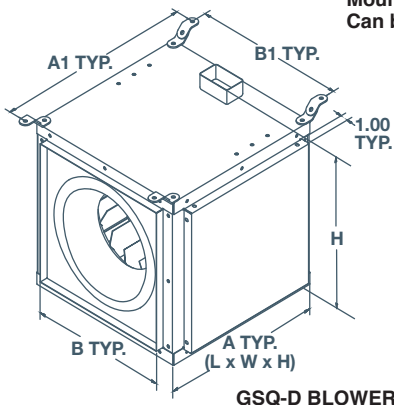

GSQ-D BLOWER

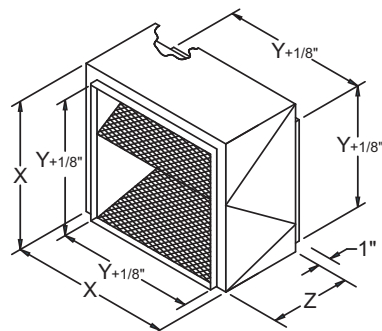

FILTER SECTION

F-GSQ FILTER SECTION					
MODEL	A	B	Z	FILTER FACTOR	UNIT WEIGHT(LBS)
F-DSQ090	15 5/64"	11 5/64"	6"	7.085	9 lbs
F-DSQ105	20"	14"	6"	7.085	10
F-DSQ120	20"	17"	6"	3.069	13
F-DSQ135	22"	18 3/4"	6"	2.184	15
F-DSQ150	24 1/2"	20 7/8"	14"	0.762	26
F-DSQ165	26"	23"	14"	0.63	27
F-DSQ180	28 5/8"	25 3/8"	14"	0.463	30

Filter Resistance = Filter Factor x CFM² x 10⁻⁸ in. wg

ACCESSORIES

- F-DSQ Filter section with 'V' bank 1" aluminum filters. (Filter rack will accept customer supplied 2" filters).
- Suspension or base mount vibration isolators.
- Insulated cabinet available (see price list).

RELATED MODEL

GSQ-B
 Backward Inclined Belt Drive Square Inline Blower

