

# Direct Drive Tube Axial Duct Fans

## DDA SERIES

Minimum maintenance.  
Maximum efficiency.

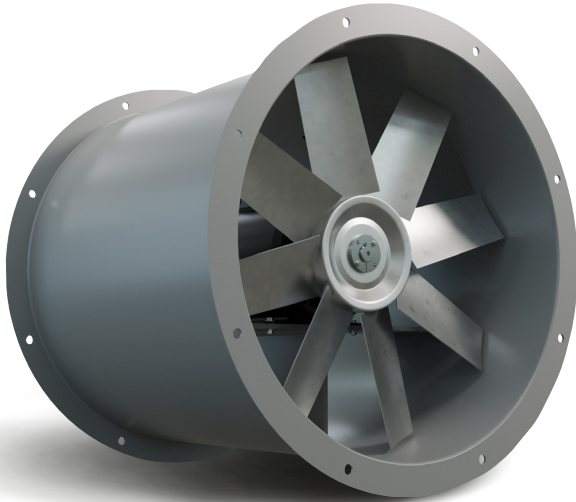

### FEATURES

**DDA** - FOR CLEAN, DRY AIR WITH A  
MAXIMUM TEMPERATURE OF 100°F (40°C)

- Cast aluminum blades are standard.
- TEFC motors are standard.

### DIMENSIONS

FAN SIZE	A	B	C	D	WEIGHT (lbs) without motor
12"	15 1/8"	14"	12"	17"	37
14"	17 3/8"	16"	14 3/8"	17"	TBA
15"	17 7/8"	17"	15 3/8"	17"	42
16"	19 3/8"	18"	16 3/8"	21"	TBA
18"	20 7/8"	20"	18 3/8"	21"	55
20"	23 3/8"	22"	20 3/8"	21"	TBA
24"	27 3/8"	25 7/8"	24 3/8"	21"	102
30"	33 3/8"	32 3/8"	30 3/8"	21"	138
34"	37 3/8"	36 3/8"	34 3/8"	27"	169
36"	39 3/8"	38 3/8"	36 3/8"	27"	181
42"	45 3/8"	44 3/8"	42 3/8"	32"	225
48"	51 3/8"	50 3/8"	48 3/8"	32"	308

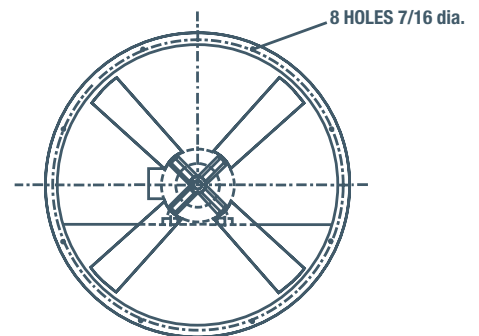
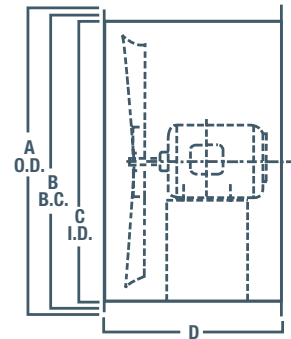



**DDA SERIES**

**Direct Drive Tube Axial Duct Fans**

**TECHNICAL SPECIFICATIONS**

**PERFORMANCE SPECIFICATIONS**

MODEL #			RPM	H.P.	dBA @ 5 ft.	CFM @ STATIC PRESSURE					
	SINGLE PHASE	THREE PHASE				0"	1/4"	1/2"	3/4"	1"	1 1/4"
	12"	DDA12T10033B				DDA12T30033B*	1750	1/3	49	1450	1230
	DDA12T10200A	DDA12T30200A*	3450	2.0	72	2860	2740	2640	2530	2410	2140
14"	DDA14T10033C	DDA14T30033C*	1140	1/3	53	1450	443	-	-	-	-
	DDA14T10033B	DDA14T30033B*	1750	1/3	60	2220	1920	1350	512	185	-
15"	DDA15T10033B	DDA15T30033B*	1750	1/3	65	2630	2320	1840	-	-	-
	DDA16T10033C	DDA16T30033C*	1140	1/3	56	2150	1640	340	-	-	-
16"	DDA16T10050B	DDA16T30050B*	1750	1/2	66	3300	3040	2690	1750	825	370
	DDA18T10033C	DDA18T30033C*	1140	1/3	59	2990	2450	845	-	-	-
	DDA18T10075B	DDA18T30075B*	1750	3/4	71	4590	4280	3910	3260	1750	-
	DDA20T10033C	DDA20T30033C*	1140	1/3	60	4530	3180	739	-	-	-
20"	DDA20T10100B	DDA20T30100B*	1750	1.0	76	6950	6155	5300	3225	1860	853
	DDA20T10200B	DDA20T30200B*	1750	2.0	78	7893	7486	6506	5336	4060	2513
	DDA24T10050C	DDA24T30050C*	1140	1/2	52	4990	4180	2920	1210	-	-
	DDA24T10100C	DDA24T30100C*	1140	1.0	57	6520	5630	4380	1920	813	-
24"	DDA24T10150C	DDA24T30150C*	1140	1.5	61	8710	7630	6020	2380	720	-
	DDA24T10150B	DDA24T30150B*	1750	1.5	65	7660	7160	6620	5980	5170	4020
	DDA24T10200B	DDA24T30200B*	1750	2.0	66	9210	8660	8090	7470	6660	5540
	DDA24T10300B	DDA24T30300B*	1750	3.0	71	11500	10900	10200	9490	8680	7540
	DDA30T10100C	DDA30T30100C*	1140	1.0	57	8680	7480	6000	3630	1550	-
	DDA30T10150C	DDA30T30150C*	1140	1.5	61	11800	10600	8950	6070	3070	-
	DDA30T30200C	DDA30T30200C*	1140	2.0	62	12780	11490	9850	7320	3620	-
30"	-	DDA30T30300C*	1140	3.0	68	16400	14700	12700	6840	4120	-
	DDA30T10300B	DDA30T30300B*	1750	3.0	69	13300	12550	11700	11000	9980	8830
	DDA30T10500B	DDA30T30500B*	1750	5.0	73	18200	17350	16550	15200	14600	13880
	DDA30T10750B	DDA30T30750B*	1750	7.5	77	22600	21980	20650	19030	18300	17550
	-	DDA34T30200C*	1140	2.0	64	15300	13800	12000	10490	6070	3440
	-	DDA34T30300C*	1140	3.0	67	19300	17700	15600	12900	8620	6110
	-	DDA34T30500C*	1140	5.0	70	22500	20550	18300	13100	10200	6860
34"	DDA34T10500B	DDA34T30500B*	1750	5.0	76	18700	17820	16800	15700	14600	13660
	DDA34T10750B	DDA34T30750B*	1750	7.5	76	23500	22600	21500	20400	19300	18160
	-	DDA34T31000B*	1750	10.0	78	27800	26750	25500	24250	23300	22150
	-	DDA34T31500B*	1750	15.0	81	31300	30300	29100	28250	26600	25130
	-	DDA36T30200C*	1140	2.0	66	14000	12400	10600	8390	5530	-
	-	DDA36T30300C*	1140	3.0	67	19400	17550	15600	13100	8980	6450
	-	DDA36T30500C*	1140	5.0	68	23600	22050	19700	16850	11700	9220
36"	DDA36T10500B	DDA36T30500B*	1750	5.0	70	16200	15200	14200	12800	12200	11050
	-	DDA36T30750C*	1140	7.5	72	26100	23800	21600	18350	12900	9730
	DDA36T10750B	DDA36T30750B*	1750	7.5	78	21500	20400	19400	18350	17100	15850
	-	DDA36T31000B*	1750	10.0	79	29700	28550	27300	26150	24900	23700
	-	DDA36T31500B*	1750	15.0	81	34320	32960	31970	30680	29280	28030
	-	DDA42T30200D*	860	2.0	61	19200	16300	12400	6720	-	-
	-	DDA42T30300D*	860	3.0	63	23210	20230	16280	8980	3940	-
	-	DDA42T30500D*	860	5.0	66	28900	25600	20800	11100	6290	-
	-	DDA42T30500C*	1140	5.0	68	25500	23550	21100	18300	14200	10100
42"	-	DDA42T30750C*	1140	7.5	70	30690	28750	26190	23350	19410	12780
	-	DDA42T31000C*	1140	10.0	73	38300	35700	33100	29450	23000	15400
	-	DDA42T31000B*	1750	10.0	76	26700	25200	23750	22380	21100	19570
	-	DDA42T31500B*	1750	15.0	80	39100	38080	36700	34640	33500	32040
	-	DDA42T32000B*	1750	20.0	82	43300	42280	40860	39170	37600	36140
	-	DDA48T30500D*	860	5.0	66	29820	26940	23790	12790	12790	6740
	-	DDA48T30750D*	860	7.5	68	35700	32450	28600	16800	16800	8270
48"	-	DDA48T31000C*	1140	10.0	74	37200	35300	33200	30800	27700	24000
	-	DDA48T31500C*	1140	15.0	76	47300	45050	42300	36200	36200	33490
	-	DDA48T32000C*	1140	20.0	79	53900	51450	48400	42300	42300	37120

BLADE DIAMETER

For three phase motors, substitute "\*" with "M" for 230/460 volt (If 208V required please specify) or "P" for 575 volt. dBA ratings shown are measured at 0" static pressure and should be used as a guideline only



## TUBE AXIAL DUCT FAN OPTIONS & ACCESSORIES

When ordering, replace "T" in the Model Number (in the Performance Specification Chart) with ALL accessory code as shown on this page.

**Options must be requested at time of order, as they cannot be added later.  
Non-stock, made-to-order products are non-returnable and cannot be cancelled.**



### DISCONNECT SWITCH

Accessory Code: **A**

See page K4 in Controls & Thermostats section for more information.

*Ships loose.*

Available as an accessory ordered separately.



### INLET GUARDS OUTLET GUARD

Accessory Code:

#### B Inlet | J Outlet

Spiral plated OSHA guard. Fits intake or exhaust. Can be used in conjunction with companion ring. To order installed, add letter to part number.

Also available as an accessory ordered separately.



### CR - COMPANION RING

Accessory Code: **C**

1/4" plate angle ring. Used to attach guards or ducts to tube axial fans. To order installed, add letter to part number.

Also available as an accessory ordered separately.



### SCV - VERTICAL SUPPORT CLIPS

Accessory Code: **D**

1/4" plate horizontal support clips.

Bolts to the vertical support clips welded to the fan. Two clips per end. Must be used with vertical clips (D).

Must be requested at time of order.

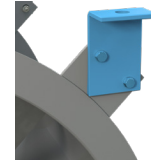

### SCH - HORIZONTAL SUPPORT CLIP

Option Code: **K**

Heavy duty support legs welded to the fan.

Suitable for floor-mount tube axial fans. 4" standard; 16" available (consult factory). Sold in pairs.

Must be requested at time of order.

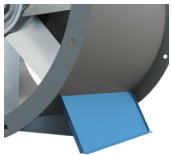

### SPL - SUPPORT LEGS

Accessory Code: **E**

Heavy duty support legs welded to the fan. Suitable for floor-mount tube axial fans.

4" standard; 16" available (consult factory). Sold in pairs. Must be requested at time of order.



### MCVR - MOTOR & BELT COVER

Accessory Code: **F**

8-gauge galvanized steel. Acts as both motor and belt cover.

3/4" expanded-metal screen allows motor heat escape. Bolts to motor mount. For HTA/BTA/WTA fans only. To order installed, add letter to part number.

Also available separately.



### BLG - BELT GUARD

Accessory Code: **G**

Protects belts and drives. 18-gauge galvanized steel.

For HTA/BTA/WTA fans only. Not required if using Motor Cover (F).

To order installed, add letter to part number. Also available separately.

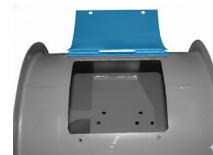

### ID - INSPECTION DOOR

Accessory Code: **H**

10" x 12" hinged and bolted door. Air-dry finish. Can be installed in a location specified by customer.

Must be requested at time of order.



### WC - WEATHER COVER

Accessory Code: **L**

18-gauge galvanized steel. Acts as both motor and belt cover.

Fully enclosed for weather protection. Bolts to motor mount. For HTA/BTA/WTA fans only. To order installed, add letter to part number.

Also available separately.

### SPECIALS

Accessory Code: **I**

Explosion-proof motors  
Steel fan blades  
Optional coating

Must be requested at time of order.

## ORDERING EXAMPLES



**EX 1)** If ordering a BTA18T10050 with support legs (E) and an inspection door (H), use E & H here: **BTA18EH10050**.

**EX 2)** If ordering a BTA18T10050 with horizontal clips & belt guard, use **BTA18DKG10050**.

### WIRED JUNCTION BOX

Option Code: **W**

Wired junction box using BX cable.

For BTA models only.

Must be requested at time of order.

ACCESSORIES			OPTIONS INSTALLED WELDED TO TUBE			
FAN SIZE	COMPANION RING	GUARD	HORIZONTAL CLIP	SUPPORT LEG	VERTICAL CLIP	INSPECTION DOOR
12"	CR12P	MC12G		SPL12		ID12
15"	CR15P	MC15G		SPL15		ID15
18"	CR18P	MC18G		SPL18		ID18
20"	CR20P	MC20G		SPL20		ID20
24"	CR24P	MC24G		SPL24		ID24
30"	CR30P	MC30G	SCH12-60 (Must order vertical clip accessory)	SPL30	SCV12-60	ID30
34"	CR34P	MC34G		SPL34		ID34
36"	CR36P	MC36G		SPL36		ID36
42"	CR42P	MC42G		SPL42		ID42
48"	CR48P	MC48G		SPL48		ID48
54"	CR54P	MC54G		SPL54		ID54
60"	CR60P	MC60G		SPL60		ID60

ACCESSORIES		
BTA SIZE	WEATHER COVER	MOTOR COVER
12" - 18"	MCVR1-WP	MCVR1
24" - 30"	MCVR2-WP	MCVR2
34" - 36"	MCVR3-WP	MCVR3
42" - 48"	MCVR4-WP	MCVR4
54" - 60"	MCVR5-WP	MCVR5

ACCESSORIES	
FRAME SIZE	BELT GUARD
48 - 145T	BLGD1
182T - 184T	BLGD2
213T - 256T	BLGD3
284 AND UP	BLGD4