

COMMERCIAL BATHROOM EXHAUST FANS



BPT SERIES BATHROOM EXHAUST FANS

- Canarm BPT series bathroom ventilators are high quality, low noise units which meet the needs of today's quality builders and contractors.
- With CFM ratings of 70, 110 and 150, we have units to meet every size bathroom.

BPT12-13H1

FOR BATHROOM SIZE UP TO 75 FT²



- 70 CFM
- 1.5 sone
- 17 Watts
- 120 V Motor
- 4" outlet
- Comes with plastic grill
- Shipping weight: 8.0 lbs.



DIMENSIONS

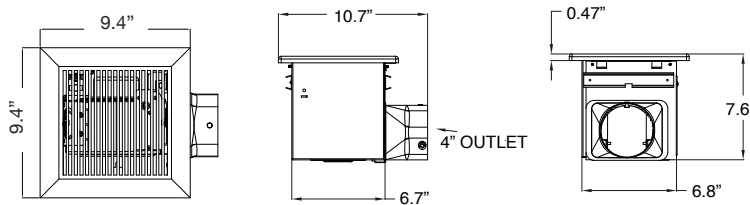

FAN CURVES

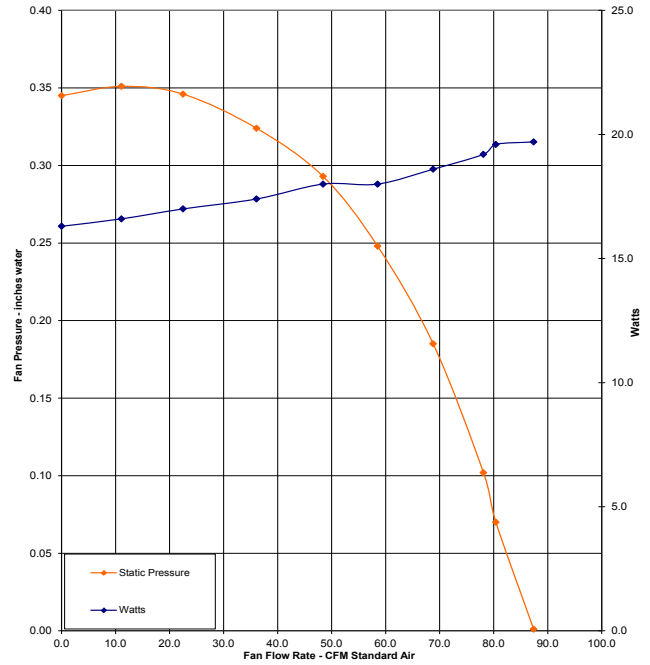

BPT18-34A-6

FOR BATHROOM SIZE UP TO 105 FT²



- 110 CFM
- 1 sone
- 31 Watts
- 120 V Motor
- 4" outlet
- Comes with plastic grill
- Shipping weight: 13.9 lbs.



DIMENSIONS

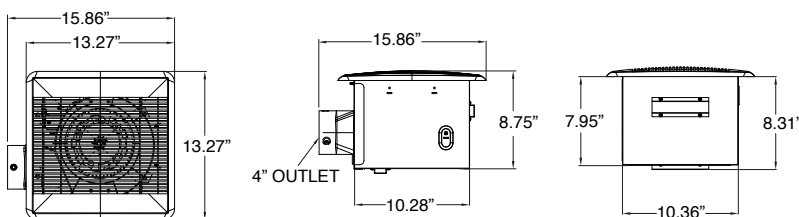

FAN CURVES

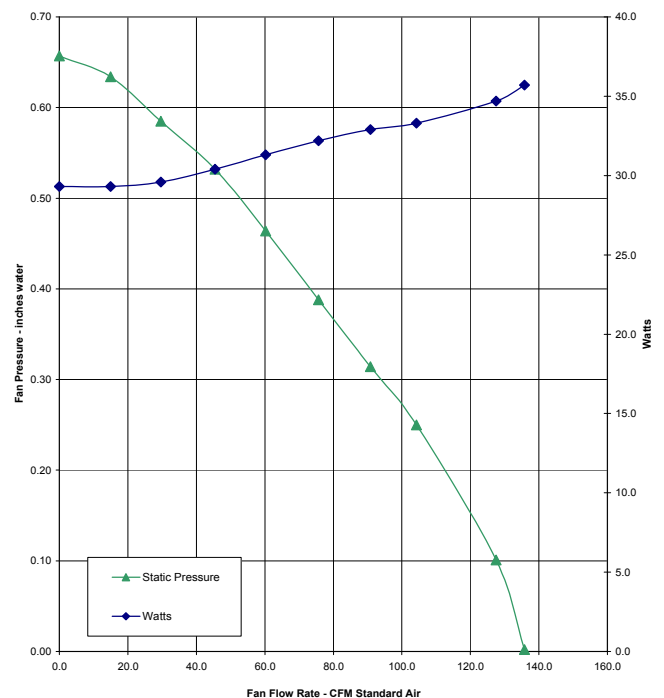

C SERIES

Ceiling Exhaust Fans



The C Series is HVI certified and exhausts air efficiently. Made of corrosion resistant galvanized steel for long life and durability.

FEATURES

- Easy to install with torsion mounting - no tools required!
- Housing made of rugged 26 GA galvanized steel with built in mounting brackets.
- Detachable 3" poly collar.
- Permanently lubricated 120V motor with overload disconnect.
- HVI certified.
- ETL and cETLus listed for tub and shower when connected to a GFCI.
- Premium low profile poly grille.
- Duct to a roof vent or wall cap using a 3" round pipe.
- Removable blower assembly with a centrifugal blower wheel and permanently lubricated motor designed for continuous operation.
- Optional light kit.

PERFORMANCE SPECIFICATIONS

Model	Static Pressure (Inches w.g.)	Air Volume (CFM)	Noise Level (Sones)	Watts	Power Rating (V/Hz)	Duct Diameter
C50	0.1	50	4.8	45	120/60	3"

DIMENSIONS

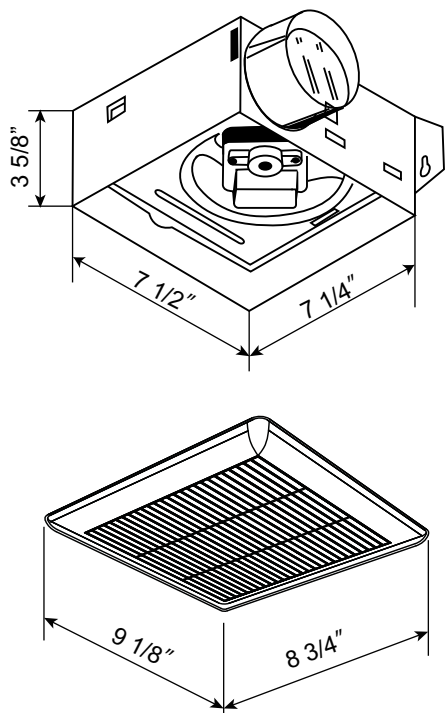

FAN CURVES

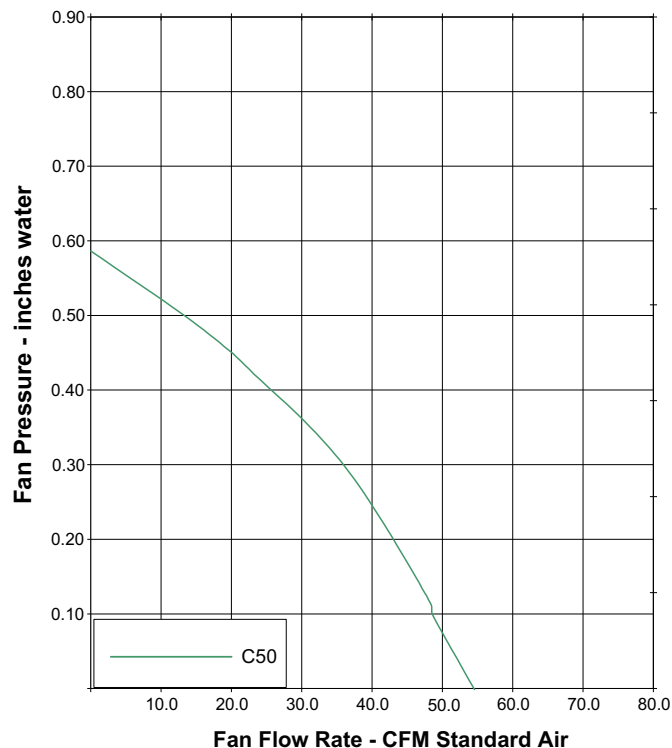



Shown with optional LED light kit



CP SERIES

Ultra Quiet, High Performance Exhaust Fans

Canarm's CP series fans are ultra quiet and come complete with efficient and long lasting capacitor start motor.

FEATURES

- Ultra quiet operation..
- Plug in permanently lubricated motor engineering for continuous operation.
- Motor comes with a built in overload disconnect for safety and long life.
- Holds an ETL evaluation and conforms to UL and cUL safety standards.
- Rugged 26 GA galvanized steel housing.
- Detachable 4" polymeric collar which includes a light weight built-in back draft damper.
- HVI and Energy Star approved.
- Elegant yet simple, low profile grille.

PERFORMANCE SPECIFICATIONS

MODEL	CFM	STATIC PRESSURE (IN W.G.)	SONES	WATTS	POWER (V/Hz)	DUCT DIAMETER
CP50	50	0.1	0.4	17	120/60	4"
	42	0.25	N/A			
CP80	80	0.1	1.0	22	120/60	4"
	72	0.25	N/A			

ACCESSORIES

- LED light kit

DIMENSIONS

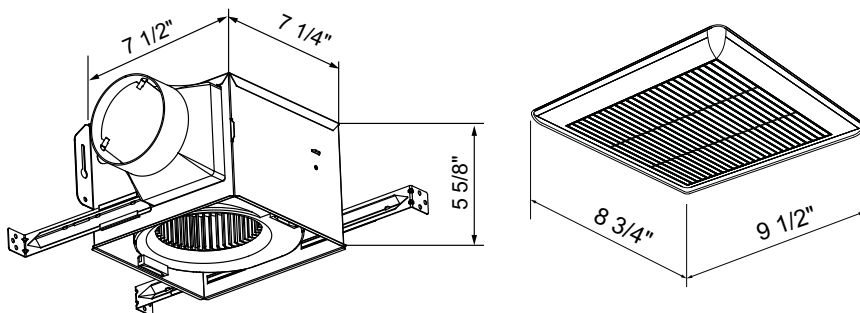

FAN CURVES

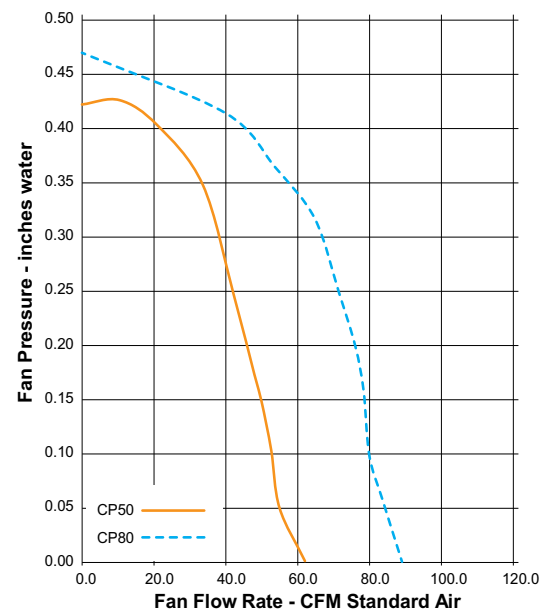



CNP SERIES

Ultra Quiet, Compact Design Exhaust Fans

Canarm's CNP fans come complete with high efficiency motors meeting Energy Star requirements. The CNP fans are ultra quiet, compact and easily customizable with optional accessories.

FEATURES

- Ultra quiet.
- Compact design.
- High performance and efficiency
- Holds an ETL evaluation and conforms to UL and cUL safety standards.
- 4" polymeric collar which includes a light weight built-in back draft damper.
- HVI and Energy Star approved.
- Elegant yet simple, low profile grille.

PERFORMANCE SPECIFICATIONS

MODEL	STATIC PRESSURE (IN W.G.)	CFM	SONES	WATTS	POWER (V/Hz)	DUCT DIAMETER
CNP50	0.1	50	0.4	13W	120/60	4"
	0.25	37	N/A			
CNP80	0.1	80	0.6	18W	120/60	4"
	0.25	60	N/A			
CNP100	0.1	100	0.8	23W	120/60	4"
	0.25	97	N/A			

ACCESSORIES

- LED light
- Humidity sensor
- Motion sensor
- Speed controller

DIMENSIONS

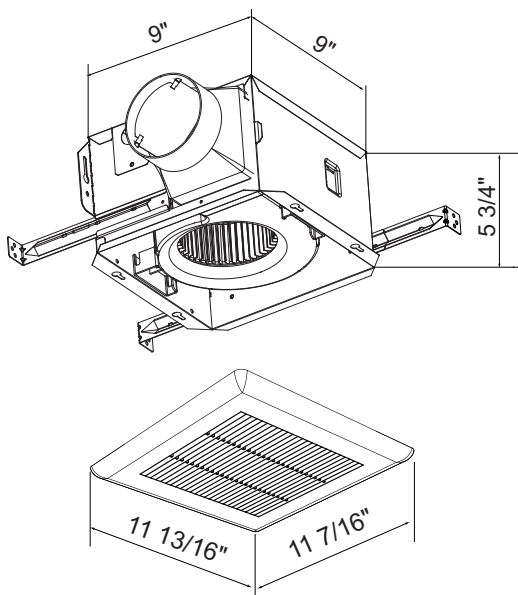

FAN CURVES

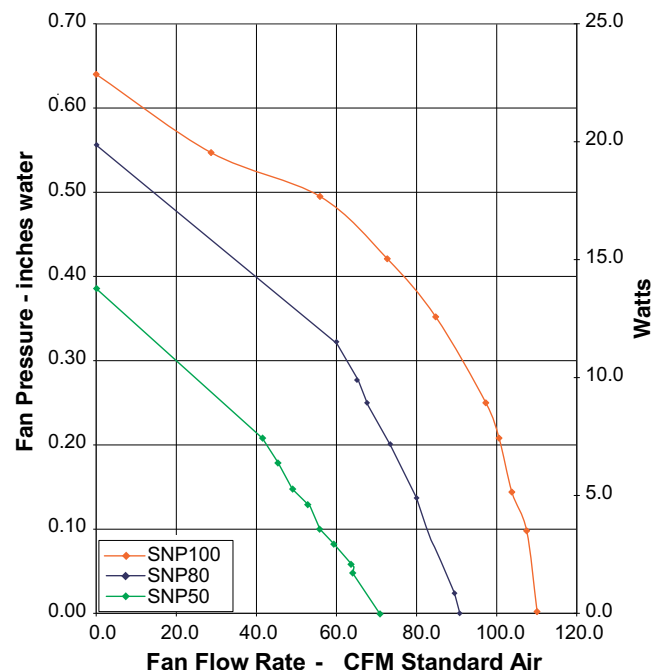

NEW



CNPD100-3 SERIES

Ultra Quiet, Compact Design Exhaust Fans

Canarm's CNPD100-3 fans come complete with high efficiency DC motors meeting Energy Star requirements. The CNPD100-3 fans are ultra quiet, compact and easily customizable with optional accessories.

FEATURES

- ETL evaluated and conforms to UL and cUL safety standards.
- Built in toggle switch for CFM (50/80/100) selection
- Totally enclosed brushless DC motor designed to operate continuously
- Detachable 4" polymeric collar which includes a light weight built-in back draft damper
- HVI and Energy Star approved.
- Elegant yet simple, low profile grille.

ACCESSORIES

- LED light grille

DIMENSIONS

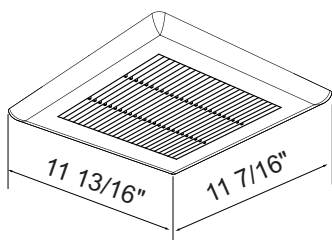
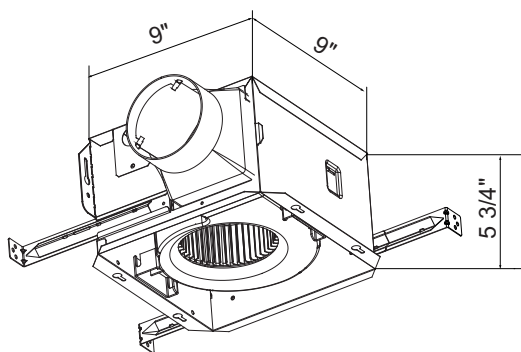

SWITCH

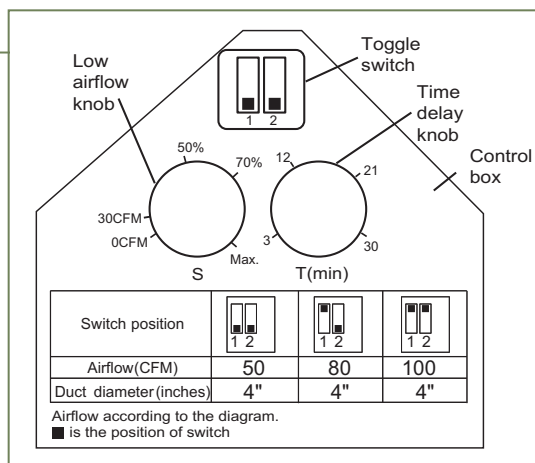

PERFORMANCE SPECIFICATIONS

MODEL	FOR BATHROOM SIZE UP TO	STATIC PRESSURE (IN W.G.)	CFM	SONES	WATTS	POWER (V/HZ)	DUCT DIAMETER
CNPD100-3	45 FT ²	0.1	50	0.3	3.3W	120/60	4"
		0.25	42	0.9			
	75 FT ²	0.1	80	0.4	5W	120/60	4"
		0.25	62	0.8			
	95 FT ²	0.1	100	0.7	8W	120/60	4"
		0.25	81	1			

FAN CURVES

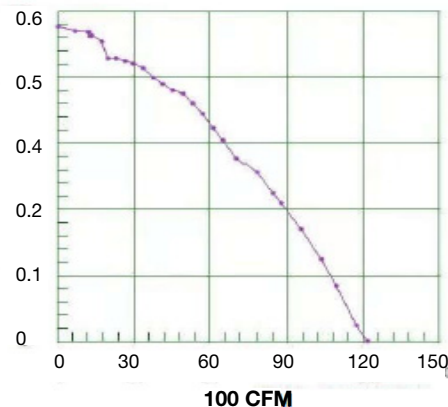
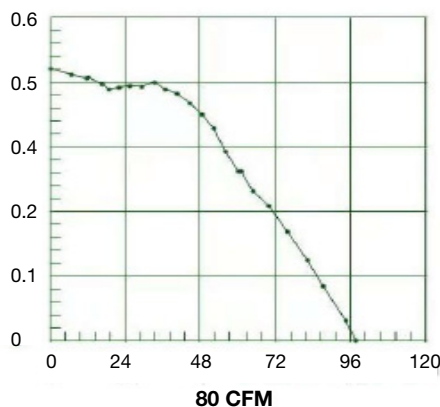
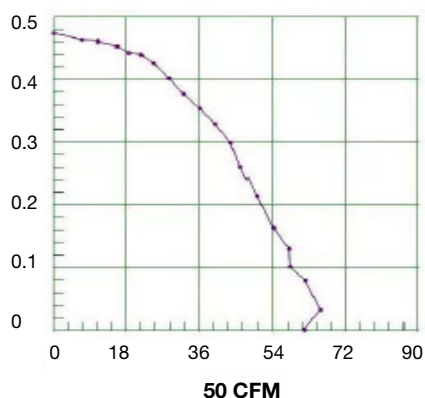



CESD100-3 SERIES

Ultra Quiet, Slimline Design Exhaust Fans

Canarm's CESD100-3 fans come complete with high performance two speed DC motors meeting Energy Star requirements. The CESD100-3 fans are ultra quiet, slimline and low profile.

FEATURES

- Ultra quiet slimline design.
- Two speed totally enclosed DC motor designed to operate continuously.
- High performance and efficiency.
- Holds an ETL evaluation and conforms to UL and cUL safety standards.
- Rugged 26 GA galvanized steel housing.
- Detachable 4" polymeric collar which includes a light weight built-in back draft damper.
- HVI and Energy Star approved.
- Elegant yet simple, low profile grille.



PERFORMANCE SPECIFICATIONS

MODEL	CFM	STATIC PRESSURE (IN W.G.)	SONES	WATTS	POWER (V/HZ)	DUCT DIAMETER
CESD100-3	50	0.1	0.6	12	120/60	4"
		0.25	N/A			
	80	0.1	1	12	120/60	4"
		0.25	N/A			
	100	0.1	1.5	12	120/60	4"
		0.25	N/A			

DIMENSIONS

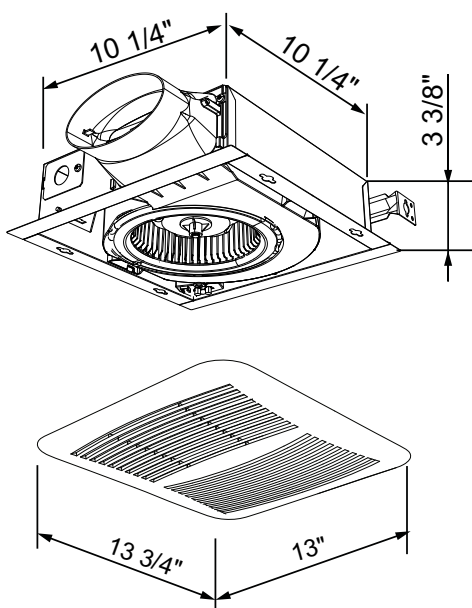

FAN CURVES

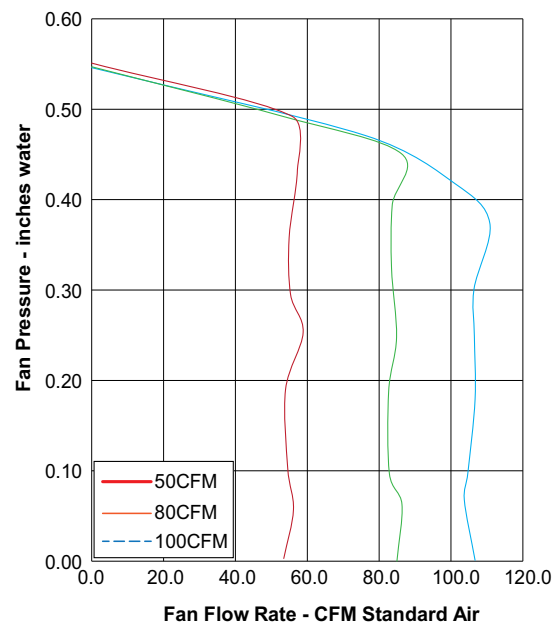

CEP SERIES

Ultra Quiet Ceiling Exhaust Fans



Canarm's CEP fans come complete with high efficiency motors meeting Energy Star requirements. The CEP fans are ultra quiet and easily customizable using plug and play accessories.

FEATURES

- Ultra quiet.
- High performance and efficiency.
- Permanently lubricated 120V motor with overload disconnect.
- 6" Poly Collar with built in backdraft damper.
- Premium low profile poly grille.
- ETL listed for tub and shower when connected to a GFCI.
- HVI and Energy Star approved.
- Plug and Play accessories.

DIMENSIONS

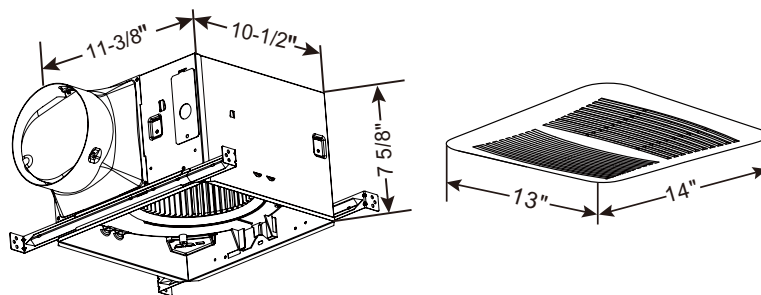

ACCESSORIES

- Humidistat
- Speed Control - internal or remote
- Light Kit
- Ceiling Radiation Damper

PERFORMANCE SPECIFICATIONS

MODEL	FOR BATHROOM SIZE UP TO	STATIC PRESSURE (IN W.G.)	CFM	SONES	WATTS	POWER (V/Hz)	DUCT DIAMETER
CEP80	75 FT ²	0.1	80	0.4	22.8	120/60	6"
		0.25	69	1.1	22.5		
CEP110	105 FT ²	0.1	110	<0.3	30.8	120/60	6"
		0.25	86	1.2	30.4		
CEP150	140 FT ²	0.1	140	0.5	35	120/60	6"
		0.25	123	1.2	34.2		

FAN CURVES

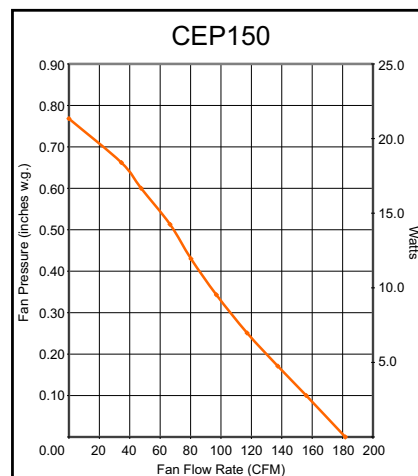
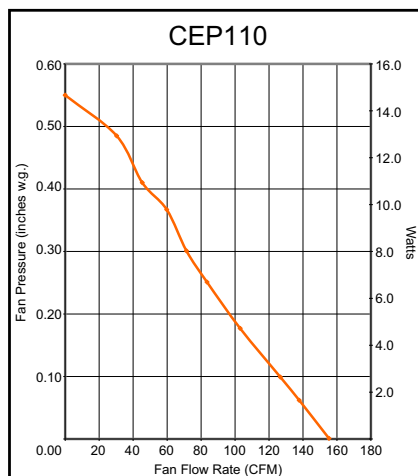
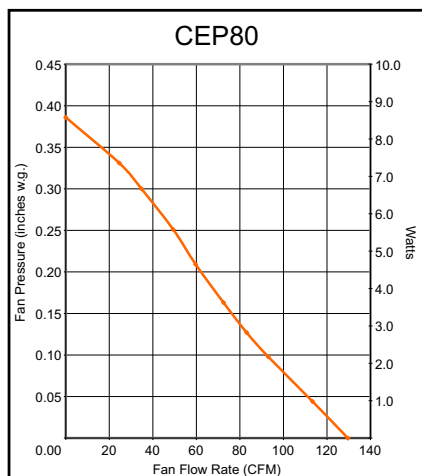

CBF SERIES

Commercial Bathroom Fan

Ideal for offices, conference rooms, public restrooms and more.

FEATURES

- Available in 4 sizes with CFM's ranging from 60 to 1500 CFM.
- EC motor with forward curved wheel.
- Built in speed control.
- Low profile, quiet and energy efficient, ceiling exhauster.
- CBF150/CBF300 come with Standard Poly Grill.
- CBF700/CBF1500 come with Standard Metal Grill.



CBF300

PERFORMANCE SPECIFICATIONS

MODEL	CFM									Sones @ 1/8" SP	Watts	Amps
	0	0.05	0.1	0.125	0.25	0.375	0.5	0.75	1			
CBF150	185	175	163	157	130	90	60	-	-	1.5	14	0.22
CBF300	330	325	320	308	300	280	260	220	180	2.9	47	0.67
CBF700	720	710	700	701	625	590	500	400	253	4.7	140	1.7
CBF1500	1656	1621	1592	1559	1444	1280	1058	170	-	8.4	372	4.9

EC motor with 0 to 10V speed control to adjust RPM to achieve desired performance.

CBF150 1.5 sonos @ nominal 1/8" static and 10V

SPEED CONTROL VOLTS	CFM						
	0	0.125	0.25	0.375	0.5	0.75	1
10	185	157	130	90	60	-	-
7.5	171	145	120	84	56	-	-
5	157	133	110	77	51	-	-
2.5	128	109	90	63	41	-	-



CBF150

CBF300 2.9 sonos @ nominal 1/8" static and 10V

SPEED CONTROL VOLTS	CFM						
	0	0.125	0.25	0.375	0.5	0.75	1
10	330	308	300	280	260	220	180
7.5	277	260	252	235	218	185	151
5	223	210	203	190	176	149	122
2.5	179	169	163	153	142	120	98



CBF700

CBF700 4.7 sonos @ nominal 1/8" static and 10V

SPEED CONTROL VOLTS	CFM						
	0	0.125	0.25	0.375	0.5	0.75	1
10	720	701	625	590	500	400	253
7.5	652	632	566	534	453	362	296
5	601	583	522	493	418	334	273
3.25	551	534	478	451	383	306	250
2.5	493	478	428	404	343	274	224
1.75	435	422	378	357	302	242	198



CBF1500

CBF1500 8.4 sonos @ nominal 1/8" static and 10V

SPEED CONTROL VOLTS	CFM						
	0	0.125	0.25	0.375	0.5	0.75	1
10	1656	1559	1444	1280	1058	170	-
7.5	1325	1204	1005	572	70	-	-
5	1082	901	469	-	-	-	-

CBF SERIES

Commercial Bathroom Fan

Ideal for offices, conference rooms, public restrooms and more.

DIMENSIONS

MODEL	HOUSING			OVERALL		OUTLET		MOUNTING			
	A	B	C	D	E	F	G	H	J	K	L
CBF150	12 1/4"	11 3/4"	12 1/4"	5 7/8"	6 1/8"	5 7/8" dia.	-	14 1/16"	1 1/4"	9 3/4"	1 5/16"
CBF300	12 1/4"	11 3/4"	12 1/4"	3 7/8"	6 1/8"	7 7/8" dia.	-	14 1/16"	1 1/4"	9 3/4"	1 5/16"
CBF700	21 1/2"	11 13/16"	12 1/4"	6 9/16"	1 7/16"	18 1/2"	4 1/2"	23 1/4"	1 5/16"	9 3/4"	1 1/4"
CBF1500	22"	18"	18 1/16"	8 1/2"	3"	16"	8"	23 3/8"	4 1/8"	10"	3 15/16"

CBF150 & CBF300

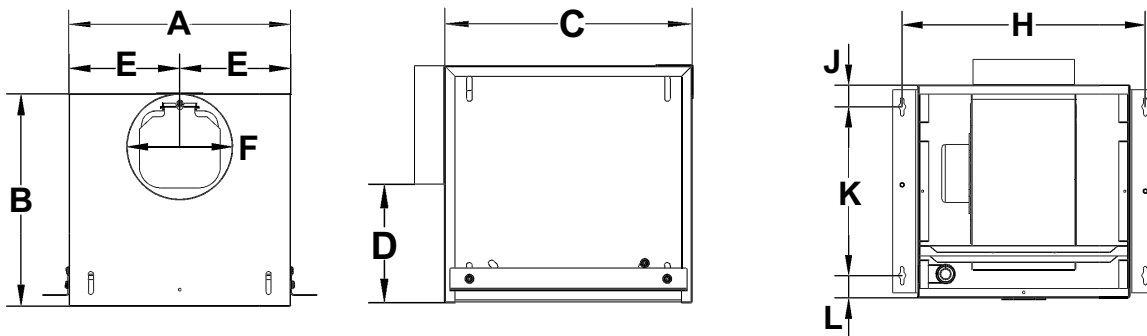

CBF700

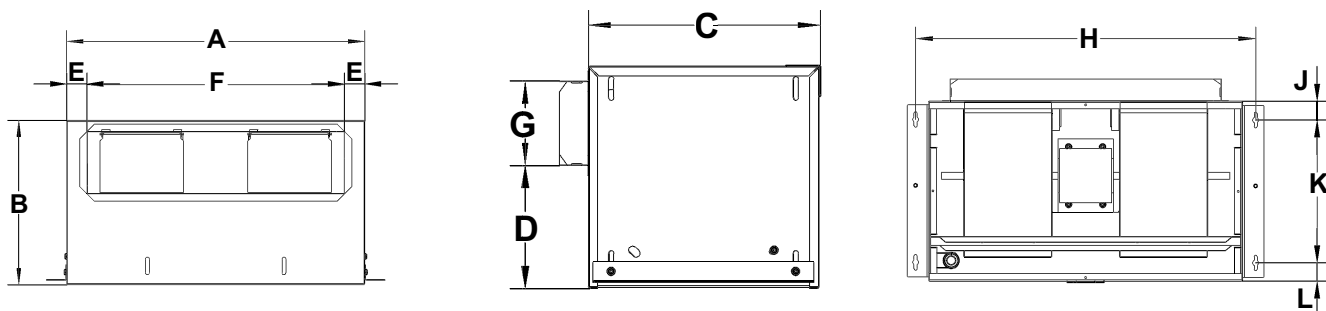

CBF1500

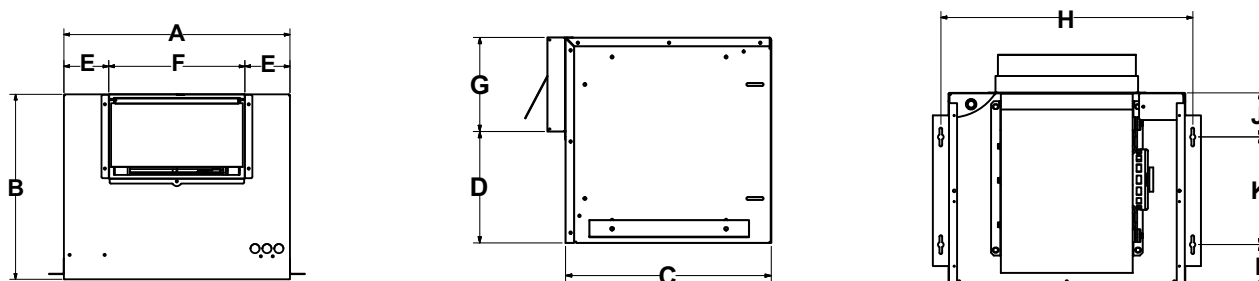

CBFI SERIES

Inline Exhausters

Ideal for offices, conference rooms, public restrooms and more.



CBF150/CBF300
INLINE
EXHAUSTER

CBF700
INLINE
EXHAUSTER

CBF1150
INLINE
EXHAUSTER

FEATURES

- Available in 4 sizes with CFM's ranging from 66 to 1200 CFM.
- EC motor with forward curved wheel.
- Built in speed control.
- Low profile, quiet and energy efficient, inline exhauster.

PERFORMANCE SPECIFICATIONS

MODEL	CFM							Sones @ 1/8" SP	Watts	Amps
	0	0.125	0.25	0.375	0.5	0.75	1			
CBF1150	149	130	114	93	66	-	-	1.5	14	0.22
CBF300	306	278	262	239	219	180	140	2.9	47	0.67
CBF700	660	634	607	574	498	380	239	4.7	218	1.7
CBF1500	1235	1153	1068	964	718	229	-	8.4	264	4.9

EC motor with 0 to 10V speed control to adjust RPM to achieve desired performance - keep control above 0.9V otherwise motor turns off!

CBF1150 1.5 sones @ nominal 1/8" static and 10V

SPEED CONTROL VOLTS	CFM						
	0	0.125	0.25	0.375	0.5	0.75	1
10	149	130	114	94	66	-	-
7.5	145	125	110	90	62	-	-
5	140	120	105	87	60	-	-
2.5	119	94	73	32	-	-	-

CBF300 2.9 sones @ nominal 1/8" static and 10V

SPEED CONTROL VOLTS	CFM						
	0	0.125	0.25	0.375	0.5	0.75	1
10	306	278	262	239	219	180	140
7.5	303	275	260	237	217	179	138
5	227	193	171	143	110	57	-
2.5	143	95	55	-	-	-	-

CBF700 4.7 sones @ nominal 1/8" static and 10V

SPEED CONTROL VOLTS	CFM						
	0	0.125	0.25	0.375	0.5	0.75	1
10	660	634	607	574	498	380	239
7.5	627	602	577	545	473	361	227
5	583	560	537	507	440	336	211
3.25	531	510	489	461	400	306	192
2.5	478	459	440	415	360	275	173
1.75	430	413	396	374	324	248	156

CBF1500 8.4 sones @ nominal 1/8" static and 10V

SPEED CONTROL VOLTS	CFM						
	0	0.125	0.25	0.375	0.5	0.75	1
10	1235	1153	1068	964	718	229	-
7.5	1110	1035	961	572	-	-	-
5	999	931	865	-	-	-	-

DIMENSIONS

CBF1150/CBF300
INLINE
EXHAUSTER

DUCT DIAMETER
CBF1150 - 6"
CBF300 - 8"

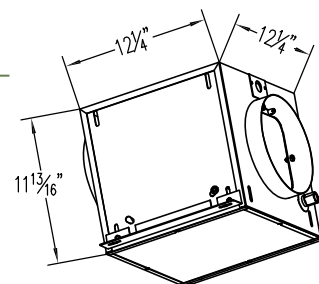

CBF700
INLINE
EXHAUSTER

DUCT DIAMETER
CBF700 - 18 1/2" x 4 1/2"

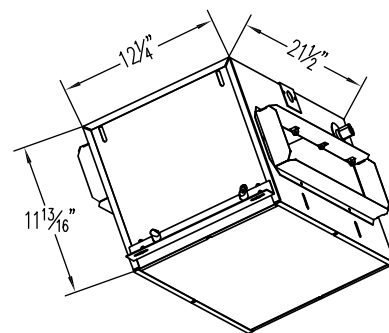

CBF1500
INLINE EXHAUSTER

DUCT DIAMETER
CBF1500 - 13 1/4" x 8 1/4"

