

CEPD SERIES

Ultra Quiet Ceiling Exhaust Fans with DC Motor



Canarm's ultra quiet CEPD fans come complete with high efficiency DC motors. Built in speed controls are standard and allow for fine tuning CFM to your needs. Optional accessories are available such as a light kit or radiation damper, and a motion sensor and humidistat are available on special order.

FEATURES

- High performance and efficiency.
- Variable speed totally enclosed DC motor with thermal protection.
- Built in speed control.
- 6" Poly Collar with built in backdraft damper.
- Premium low profile poly grille.
- ETL listed for tub and shower when connected to a GFCI.
- Energy star rated (excluding model CEPD300).



ACCESSORIES

- Light Kit
- Ceiling Radiation Damper
- Special Order Factory Options:
 - Humidistat
 - Motion Sensor

PERFORMANCE SPECIFICATIONS

MODEL	FOR BATHROOM SIZE UP TO	PERFORMANCE @ 0.1 IN W.G.				
		CFM	SONES	WATTS	POWER (V/HZ)	DUCT DIAMETER
CEPD150	140 FT ²	150	0.9	12	120/60	6"
CEPD200	185 FT ²	200	2.0	24	120/60	6"
CEPD300	275 FT ²	290	4.0	52	120/60	6"

DIMENSIONS

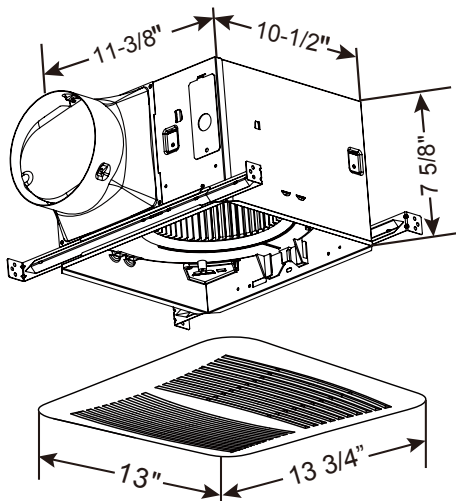

FAN CURVES

