

AVAILABLE WITH MOTORS & DRIVES FACTORY INSTALLED. CONSULT OUR DELAIR FAN SELECTION SOFTWARE FOR DETAILS.

# 400 SERIES

## FC Exhauster Belt Drive Utility Blowers

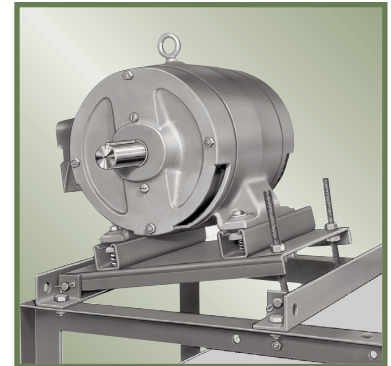

OPTIONAL 1 TO 15 HP MOTOR PLATFORM FOR MODELS 420, 422 & 425

### FEATURES

- Universal frame allows for choice of discharge position.
- Multiple choice for motor mounting location with each discharge position.
- Motor mounting hardware supplied with models 407 to 418.
- Optional platform for models 420 to 425.
- Keywayed shafts
- Ball bearings suitable for -65° to + 250° F.
- Spider bearing brackets for models 407 - 418. Pillow block bearings with T bar support for models 420, 422 & 425.
- Optional back draft dampers, inlet & outlet screens and belt guards.
- Shafts 420, 422 & 425 models are keywayed for wheels and pulleys (407 to 418 models for pulleys only).

### PERFORMANCE SPECIFICATIONS

MODEL	TYPICAL MAXIMUM CFM @ SP										Max HP
	1/2" SP		1" SP		1 1/2" SP		2" SP		2 1/2" SP		
	CFM	FEI	CFM	FEI	CFM	FEI	CFM	FEI	CFM	FEI	
407	1000	0.47	900	0.56	800	0.63	700	0.64	500	0.59	1
409	2100	0.52	2000	0.62	1900	0.71	1800	0.79	1700	0.85	2
410	2600	0.61	2400	0.72	2300	0.80	2200	0.88	2000	0.99	2
412	3000	0.70	2800	0.82	2700	0.90	2500	0.97	2300	1.06	2
415	5300	0.76	4800	0.86	4500	0.95	4200	1.03	3600	1.00	3
418	6700	0.60	6300	0.68	5900	0.77	5500	0.84	5200	0.91	5
420	9300	0.52	8900	0.62	8500	0.72	8100	0.80	7700	0.87	7-1/2
422	10300	0.54	9800	0.64	9200	0.74	8600	0.82	8000	0.88	7-1/2
425	14300	0.87	13500	0.68	12500	0.76	11900	0.84	11400	0.94	10

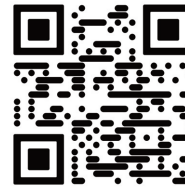

View FEI charts  
[canarm.com/fei-400](http://canarm.com/fei-400)

Power rating (BHP) does not include transmission losses. Performance certified is for installation type B: Free inlet, Ducted outlet. Performance ratings do not include the effect of appurtenances (accessories).

FOR FAN CURVES & FULL PERFORMANCE DATA, CONSULT OUR DELAIR SOFTWARE. [WWW.CANARM.COM/DELAIR](http://WWW.CANARM.COM/DELAIR)

### DIMENSIONS

MODEL	A	B	D	E	F	G	H	J	K	L	M	N	O	P	R	S	WHEEL DIAMETER	WHEEL WIDTH	UNIT WEIGHT (LBS) (without motor)
407	14 1/4"	6 1/2"	8 3/8"	6 7/8"	11 5/8"	8 5/8"	8"	11 1/16"	8 7/8"	11 3/4"	3/4"	3/4"	9"	9"	1 1/2"	7/16"	8 1/26"	4 15/16"	16
409	17 1/4"	7 15/16"	10 1/4"	9 3/16"	13 15/16"	10 1/8"	10 5/16"	14 5/8"	11 3/4"	14 1/2"	3/4"	3/4"	10"	11 5/16"	1 1/2"	7/16"	9 13/16"	7 3/16"	23
410	19 1/8"	9"	11 3/8"	9 3/16"	13 15/16"	11 1/4"	10 5/16"	16 1/4"	13 1/2"	16 1/4"	3/4"	3/4"	12"	11 5/16"	1 1/2"	7/16"	11 1/8"	7 3/16"	26
412	22 1/4"	10 9/16"	13 1/2"	9 3/16"	13 15/16"	13"	10 5/16"	19 5/8"	16 1/4"	19"	3/4"	3/4"	14"	11 5/16"	1 1/2"	7/16"	12 7/8"	7 3/16"	30
415	29 3/4"	14 3/4"	17"	12 1/2"	17 3/8"	18 1/8"	13 3/4"	27 1/4"	22 5/8"	25 1/4"	3/4"	1"	17"	14 3/4"	1 1/2"	7/16"	15 1/2"	9 9/16"	56
418	30 3/4"	14 15/16"	18 7/8"	14"	20 3/8"	17 3/4"	15 5/8"	28 1/2"	24"	26 1/2"	3/4"	1"	18"	17 1/4"	1 1/2"	7/16"	18 1/2"	10 13/16"	87
420	38"	18 5/16"	24 3/4"	15 3/4"	24 1/4"	22 9/16"	17 1/4"	32 7/16"	25 7/16"	31 1/4"	1 1/2"	1 3/16"	21"	19 3/4"	2"	5/8"	20 7/16"	10 1/4"	189
422	41 1/2"	20 1/16"	27 1/4"	17 1/8"	25 5/8"	24 5/8"	18 5/8"	35 31/32"	28 15/32"	34 1/4"	1 1/2"	1 3/16"	22 1/2"	21 1/8"	2"	5/8"	22 1/8"	11 1/4"	214
425	46 3/4"	22 5/8"	31 1/4"	19 5/8"	28 1/2"	27 3/4"	21 1/8"	41 7/32"	32 17/32"	38 3/8"	1 1/2"	1 3/16"	26 3/4"	23 5/8"	2"	5/8"	25 1/4"	13"	252

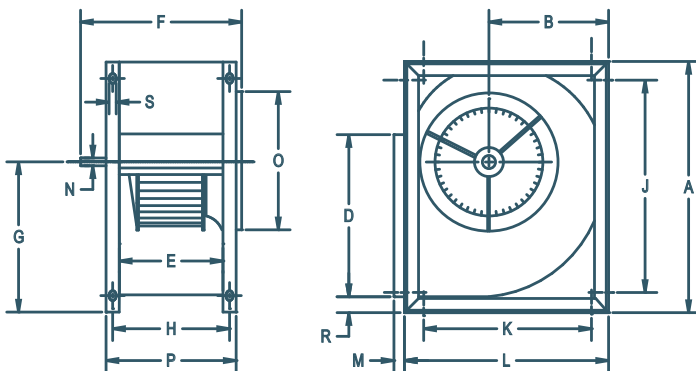

### ACCESSORIES

- Back Draft Dampers
- Inlet & Outlet Screens
- Corrosion Resistant Finishes
- Vibration Isolation
- Belt Guard

For more information on available accessories, see page C14 in Roof Mount Ventilation section.