

200, 9200 & 9200-VIB SERIES

Single & Twin Forward Curved Inline Duct Blowers



200 SERIES
Indoor Applications,
Insulated or Non-Insulated



9200 SERIES
Heavy duty, Insulated Indoor
or Outdoor Applications



9200-VIB SERIES
With Internal Spring
Vibration Isolation



Call for pricing & availability.

- As part of an HVAC system Delhi Duct Blowers will not “surge”, “hunt”, or “stall”.
- Optional variable pitch motor pulley permits field adjustment (typically + or - 15%) to match air delivery needs.
- For the quietest operational needs we offer optional internal spring isolation of the blower/motor from the housing thus greatly reducing radiated cabinet noise (9200-VIB only).
- Our twins (two duct blowers on a common shaft) is a wide but not tall solution for situations where vertical space is limited.
- Quiet forward curved blowers operate at ½ the rpm of other inline solutions.
- An outdoor series, 9200, is available.



INDUSTRIES SERVED

- Commercial HVAC
- Ventilation
- Construction
- Heating
- Cooling



Canarm certifies that the 200 & 9200 Series shown herein are licensed to bear the AMCA Seal. The ratings shown are based on tests and procedures performed in accordance with AMCA Publications 211 & 311 and comply with the requirements of the AMCA Certified Ratings Programme.

The AMCA certified ratings seal applies to air and sound performance only. The 200 & 9200 Series shown herein are not approved by AMCA for FEI ratings.

FEATURES

- **Wheel Diameters:** 7” through 20”
- **CFM:** Approximately 500 to 12,500 CFM in a single blower (Twins available).
- **Static Pressure:** Usage to about 3” static pressure is common, although allowable range is higher.
- Constructed from cold rolled steel, with green baked on powder coat. The outdoor unit uses protective galvaneal steel under the powder coat.
- Forward Curved blowers operate at low RPM for low noise levels.
- Heavy duty ball bearings suitable for -65° F to +250° F.
- Keywayed shafts both ends for clockwise or counter clockwise rotation.
- Saddle type motor mounting platform provides extended belt tension adjustment range on all models.
- 9200 series may be mounted vertically or horizontally. VIB option is horizontal mount only. Cannot be vertically mounted.

Twin Units use a common shaft for balanced air supply by each blower.

TYPICAL APPLICATIONS FOR OUR INLINE BLOWERS

- An Inline make-up air solution for cases where a rooftop curb mounted solution is not available.
- As an air moving module for systems built up with other components such as heating/cooling coils.
- Noise sensitive areas - the low rpm forward curved wheel typically radiates less vibration than higher rpm backward inclined wheel solutions.
- When the application requires an air mover in a duct system located in a ceiling space.
- Redistribution or recirculation of air in a work space.
- Interlocked with entry doors to prevent entry of cold outdoor air into retail sales space and thus greets customers with warmth.
- Bathroom/ rest room exhaust - one duct blower serving multiple intakes.

PERFORMANCE SPECIFICATIONS

MODEL	TYPICAL MAXIMUM CFM @ SP											
	1/2" SP		1" SP		1 1/2" SP		2" SP		2 1/2" SP		Min HP	Max HP
	CFM	FEI	CFM	FEI	CFM	FEI	CFM	FEI	CFM	FEI		
207	1400	0.80	1300	0.96	1100	1.05	1000	1.08	800	1.04	1/6	3/4
209	2000	0.91	1800	1.09	1500	1.21	1100	1.12	800	1.04	1/6	3/4
9209	2500	0.65	2400	0.81	2300	0.91	2100	1.01	1900	1.07	1/6	1 1/2
210	3000	0.77	2800	0.96	2600	1.04	2300	1.09	1900	1.08	1/6	1 1/2
9210	3000	0.71	2800	0.90	2600	1.00	2300	1.07	1900	1.07	1/6	1 1/2
212	3700	0.86	3300	0.99	2900	1.07	2400	1.10	1600	0.93	1/6	1 1/2
9212	4900	0.63	4600	0.74	4200	0.84	3900	0.91	3500	0.98	1/6	3
215	6100	0.77	5800	0.93	5000	0.96	4100	0.94	3700	1.00	1/3	3
9215	7700	0.62	7200	0.74	6800	0.83	6300	0.91	5800	0.96	1/3	5
218	9700	0.74	9000	0.86	8200	0.96	7400	1.01	6200	0.98	1/2	5
9218	9500	0.71	8800	0.85	8000	0.93	7200	0.98	6100	0.97	1/2	5
9220	16000	0.45	15400	0.54	14800	0.62	14100	0.69	13300	0.75	3/4	15

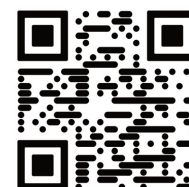

View FEI charts
canarm.com/fei-200

Power rating (BHP) does not include transmission losses. Performance certified is for installation type B: Free inlet, Ducted outlet. Performance ratings do not include the effect of apertures (accessories).

CONSULT OUR DELAIR SOFTWARE FOR FAN CURVES & FULL PERFORMANCE DATA. WWW.CANARM.COM/DELAIR



IDB, IDB-X, 200, 9200 & 9200-VIB SERIES

Single & Twin Forward Curved Inline Duct Blowers



Twin unit available for 200, 9200, 9200-VIB models
Call for pricing & availability.

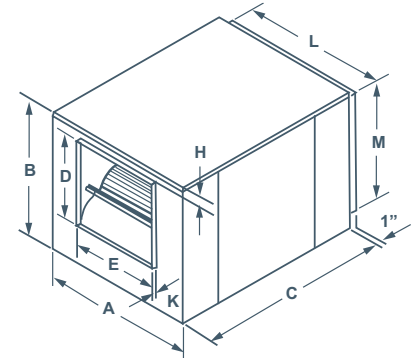
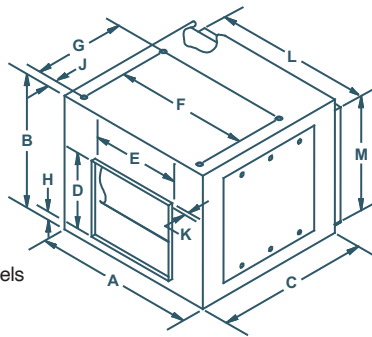

DIMENSIONS

MODEL	A	B	C	OUTLET							INLET		SHAFT DIAMETER	UNIT WEIGHT (LBS) (without motor)
				D	E	F	G	H	J	K	L	M		
IDB07 / IDB-X / 207	18"	15.375"	23"	8 1/4"	9 3/16"	14 1/2"	9 5/8"	1 1/4"	1 1/4"	7/8"	15 7/8"	13 3/8"	3/4"	43
IDB09 / IDB-X / 209	21"	18"	23"	10 1/4"	11 13/16"	17 1/2"	11 3/4"	1 1/4"	1 3/4"	7/8"	19"	16"	3/4"	55
IDB10 / IDB-X / 210	22.25"	20"	24 3/4"	11 3/8"	13 1/8"	18 3/4"	13 3/8"	1 1/4"	1 3/4"	7/8"	20 1/4"	18"	3/4"	65
IDB12 / IDB-X / 212	27"	23"	27 1/2"	13 7/16"	15 5/8"	23 1/2"	16 1/8"	1 1/4"	1 3/4"	7/8"	25"	21"	3/4"	82
IDB15 / IDB-X / 215	33.5"	28"	32"	15 7/8"	18 5/8"	28"	19 1/2"	2 5/8"	1 3/4"	7/8"	30 1/2"	25"	1"	140
218	41.5"	34"	44"	19 5/8"	22 5/8"	35"	24"	2 3/4"	1 3/4"	1 1/8"	35 3/8"	31 5/8"	1"	158
9209	21"	18"	23"	11 1/4"	12 3/4"	N/A	N/A	1"	N/A	1 1/8"	19"	16"	3/4"	61
9210	22 1/4"	20"	24 3/4"	12 3/8"	14 1/8"	N/A	N/A	1"	N/A	1 1/8"	20 1/4"	18"	3/4"	70
9212	30 1/8"	24 3/4"	34"	14 1/2"	16 5/8"	N/A	N/A	2 1/8"	N/A	1 1/8"	25 1/8"	21 1/8"	1"	143
9215	33 3/4"	28 5/8"	38 1/8"	17"	19 5/8"	N/A	N/A	2 1/8"	N/A	1 1/8"	30 5/8"	25 1/4"	1"	176
9218	41 1/2"	34"	44"	19 5/8"	22 5/8"	N/A	N/A	2 3/4"	N/A	1 1/8"	35 3/8"	31 5/8"	1"	323
9220	44 3/4"	41 1/8"	57 1/2"	25 3/4"	25 3/4"	N/A	N/A	3"	N/A	1 1/8"	38 3/8"	35 1/8"	1 7/16"	515

ACCESSORIES

- Filter sections
- Intake Hoods
- External Vibration Isolators
- Hot Water Coils
- Chilled Water Coils

FILTER SECTIONS & INTAKE HOODS

Series F200A, F9200A & H9200

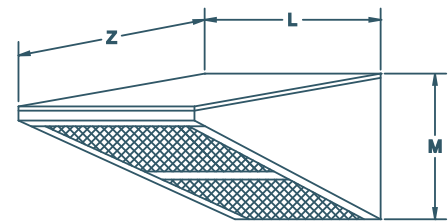
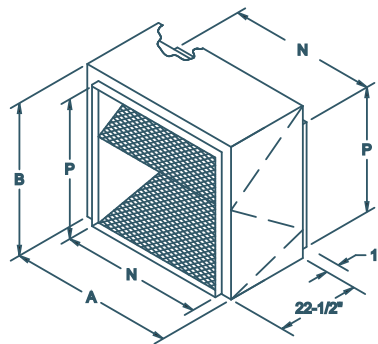
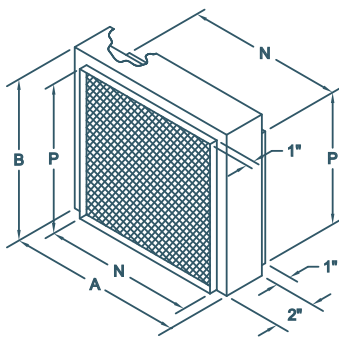

F200A FILTER SECTION
For IDB, IDB-X, 200 & 9200 Series
Duct Blowers

F9200A FILTER SECTION
For Model 9200 Duct Blowers

H9200 INTAKE HOOD
For 9200 Series Duct Blowers

MODEL	A	B	N	P	FILTER		UNIT WEIGHT (LBS)
					SIZE	QUANTITY	
F207A	17 3/4"	15 3/8"	16"	13 1/2"	14 1/8" X 16 5/8"	1	11
F209A	21"	18"	19 1/8"	16 1/8"	16 3/4" X 19 7/8"	1	12
F210A	22 1/4"	20"	20 3/8"	18 1/8"	18 3/4" X 21 1/8"	1	14
F212A	27"	23"	25 1/8"	21 1/8"	21 3/4" X 25 7/8"	1	16
F215A	32 1/2"	26 3/4"	30 5/8"	25 1/8"	25 3/4" X 31"	1	21
F218A	37"	33 1/4"	35 1/4"	31 1/2"	32 1/4" X 35 7/8"	1	46
F9220A	39 3/4"	37 1/4"	38 1/2"	35 1/4"	20" X 25"	6	64

MODEL	L	M	Z	FILTER		UNIT WEIGHT (LBS)
				SIZE	QUANTITY	
H9209	19 1/4"	16 9/16"	21 1/4"	16" X 24"	1	14
H9210	20 1/2"	18 9/16"	25 3/4"	15" X 20"	2	16
H9212	25 3/8"	21 9/16"	30 3/4"	20" X 25 & 16" X 25"	2	27
H9215	31 3/16"	25 13/16"	33 1/2"	20" X 28 1/2"	2	38
H9218	35 5/8"	32 11/16"	40 1/4"	20" X 25 (2) & 16" X 25"	3	50
H9220	38 5/8"	35 9/16"	22"	FILTERS NOT INCLUDED USE F9220A		40