

**Browning®**

PRODUCT  
CATALOG



# BROWNING® V-BELT DRIVES AND BEARINGS



**RegalRexnord™**

# The First Name in Performance HVAC Belt Drives and Bearing Products

**Part Number Explanation** ..... 10

## Belts

Super Gripbelt® ..... 11  
 Gripnotch® A, B, C ..... 12  
 FHP 2L, 3L, 4L, 5L ..... 15  
 4L, A, AX Cross Reference Guide ..... 16  
 5l, b, bx Cross Reference Guide ..... 17  
 "358" Gripbelt ..... 18

## Sheaves

Stock Sheave Interchange ..... 22-33  
 Fixed Pitch V-Belt Sheaves  
   AK-BK ..... 36-43  
   B5V® ..... 44-47  
   Gripbelt ..... 48-71  
   Q-D® ..... 72-87  
 Engineering Data ..... 88-105  
 Variable Pitch-VP, VL, VM, MVP® ..... 106-124

## Bushings

Browning Split Taper® ..... 125-128  
 Q-D ..... 129-130

## Bearings

Ball ..... 132-153

## Accessories

Tighteners, Motor Bases and Keystock

## Troubleshooting

..... 164-169

## General Information

..... 170-171

## Alpha Numerical Index

..... 172-176

## Standard Terms and Conditions

..... 178



**OEM Specified** —

# TECHNOLOGY LEADERSHIP TO MEET THE REQUIREMENTS OF SHORTER CENTERS AND HIGHER SPEEDS

## BROWNING® VP VARIABLE PITCH SHEAVES

- Increased wall thickness and hub design for increased horse power capacity and shorter center drives
- Tighter tolerances for reduced vibration
- External rib design provides extra cooling for longer belt life



## B5V® SHEAVES

- Combination groove accepts A, B and 5V belts
- B5V sheaves serves 90% of all 10-125HP applications
- B bushing utilizes the popular split taper design for true concentricity and lower vibration

## BROWNING BRAND V-BELTS

- Unique design enhances performance, provides increased horsepower capacity in short center drives
- Less fabric overlap on wrapped belts reduces vibration
- Ground form edges reduce center distance variation and drive vibration



## BROWNING TENSO-SET® SELF-TENSIONING MOTOR BASE

- Reduces time required to change belts
- Promotes greater efficiency by constantly maintaining v-belt tension
- Tube rail and one-piece carriage design promotes and maintains belt drive alignment
- Improved safety. No need to cut off belts or roll them onto sheaves



## BROWNING BEARINGS

Ball

- Air Handling "AH" option available in setscrew and concentric locking.
- Air Handling "AH" option includes specially controlled housing fit and two stage noise test.



## EDGE™

- Optimal drive selection from Regal Rexnord's vast offering of V-belt drive products
- Today's OEM trusted design tool
- Supports selections of higher HP in smaller packages



# — Contractor Preferred



## ENERGY RESPONSIBILITY IN FOUR EASY STEPS

- 1** Upgrade from wrapped to notched belts and improve efficiency
- 2** Worn sheaves allow belt slip. Inspect sheaves for wear. Wear greater than 1/32" can decrease efficiency 5% or more
- 3** Properly tension belts
- 4** Install Tenso-Set® self-adjusting motor base



**OEM Specified** —

# UPGRADE FROM WRAPPED TO NOTCHED BELTS AND IMPROVE EFFICIENCY

**RegalRexnord.com**

Visit our website for a full suite of installation instructions, product interchange software, downloadable catalogs and more.



[www.facebook.com/rexnordpt/](http://www.facebook.com/rexnordpt/)



[www.youtube.com/@RegalRexnord](http://www.youtube.com/@RegalRexnord)



[Twitter.com/RegalRexnord](https://twitter.com/RegalRexnord)

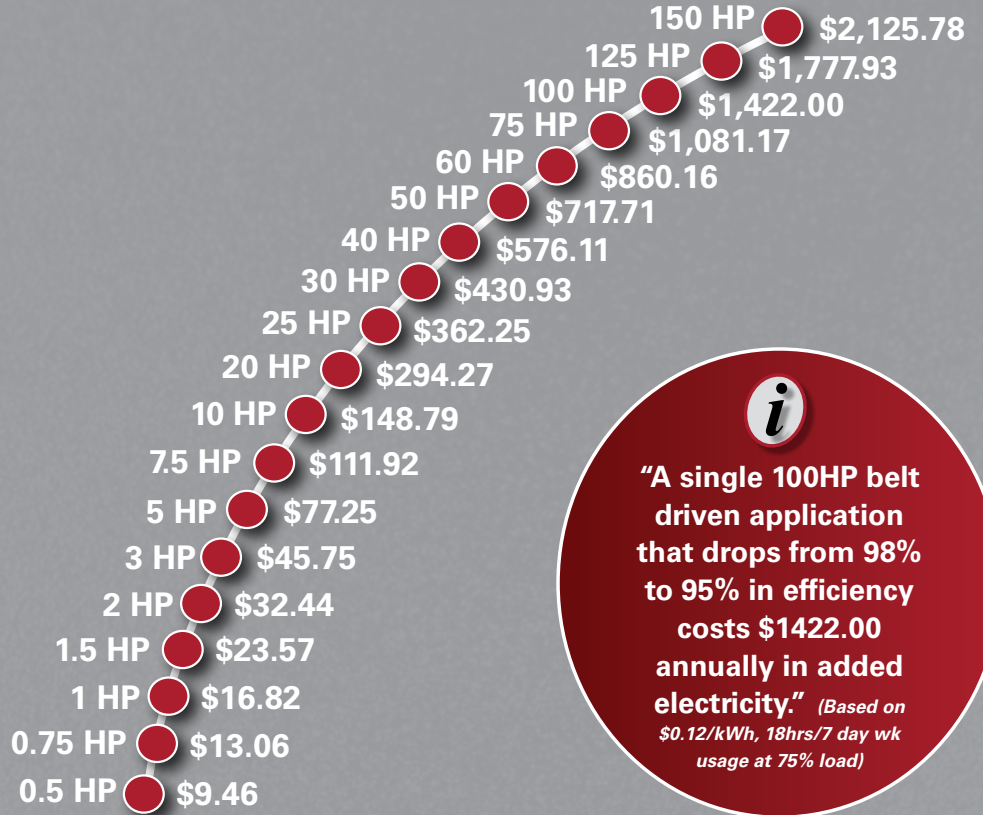

**i**

**"A single 100HP belt driven application that drops from 98% to 95% in efficiency costs \$1422.00 annually in added electricity." (Based on \$0.12/kWh, 18hrs/7 day wk usage at 75% load)**

## Try Out Our Free Toolbox Technician® App

- Energy Efficiency Calculator
- GPS-activated "Where To Buy"
- Conversion tools
- And many other great features.

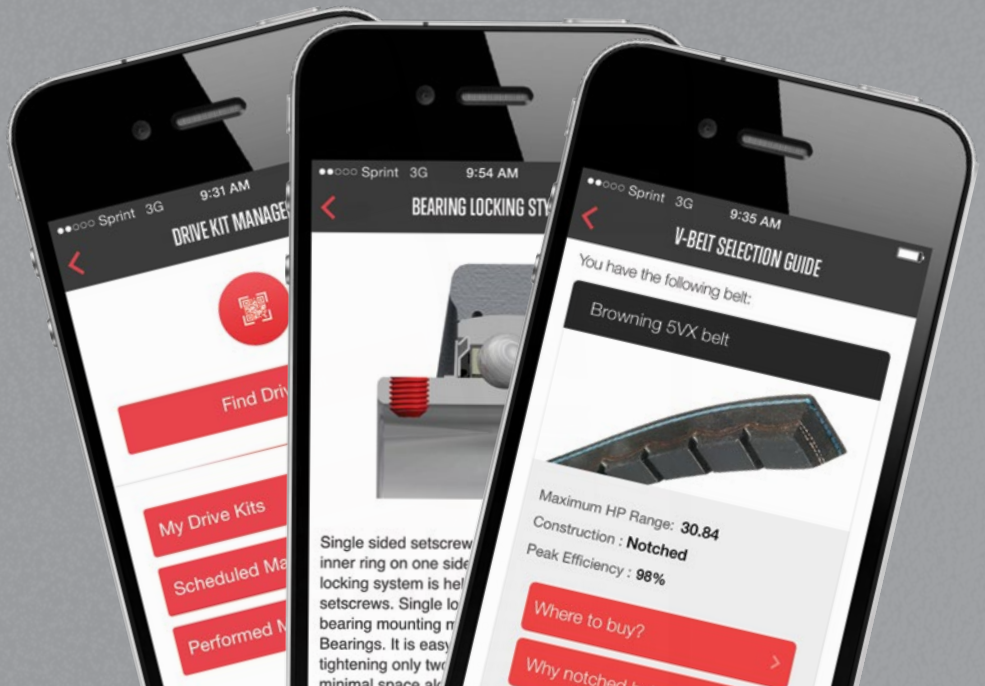

— Contractor Preferred

## V-BELT DRIVE ADVANTAGES

V-belt drives provide many maintenance advantages that help in your daily struggle to reduce equipment repairs and to hold forced downtime to the lowest possible level.

1. They are rugged—they will give years of trouble-free performance when given just reasonable attention...even under adverse conditions.
2. They are clean—require no lubrication.
3. They are efficient—performing with an average of 94-98% efficiency.
4. They are smooth starting and running.
5. They cover extremely wide horsepower ranges.
6. They permit a wide range of driven speeds, using standard electric motors.
7. They dampen vibration between driving and driven machines.
8. They are quiet.
9. They act as a “mechanical fuse” in the power drive because they refuse to transmit a severe overload of power, except for a very brief time.
10. V-belts and sheaves wear gradually—making preventive corrective maintenance simple and easy.

## LARGE SELECTION OF BROWNING V-BELTS

The Browning brand is universally known for V-belt drives.. In fact, nowhere else can you find such a complete range of V-belting — and the sheaves to run them — all in stock. Choose the type that's best for your application — Classical, "358" and FHP.

### Matched Belts

And there's no problem with matched belt sizes either. Browning offers the CODE 1® one-match belt system on all classical and "358" belts, allowing easy selection with just one match number for each belt size. The CODE 1 symbol on any Browning® belt provides matching tolerances per ARPM (Association for Rubber Products Manufacturers). Machine matching of belts is also available for precision match requirements.

Wherever you are in the universe — make Browning your first choice in V-belts.

Note: Belt matching is available upon request.  
The product will ship from our National Distribution Center.

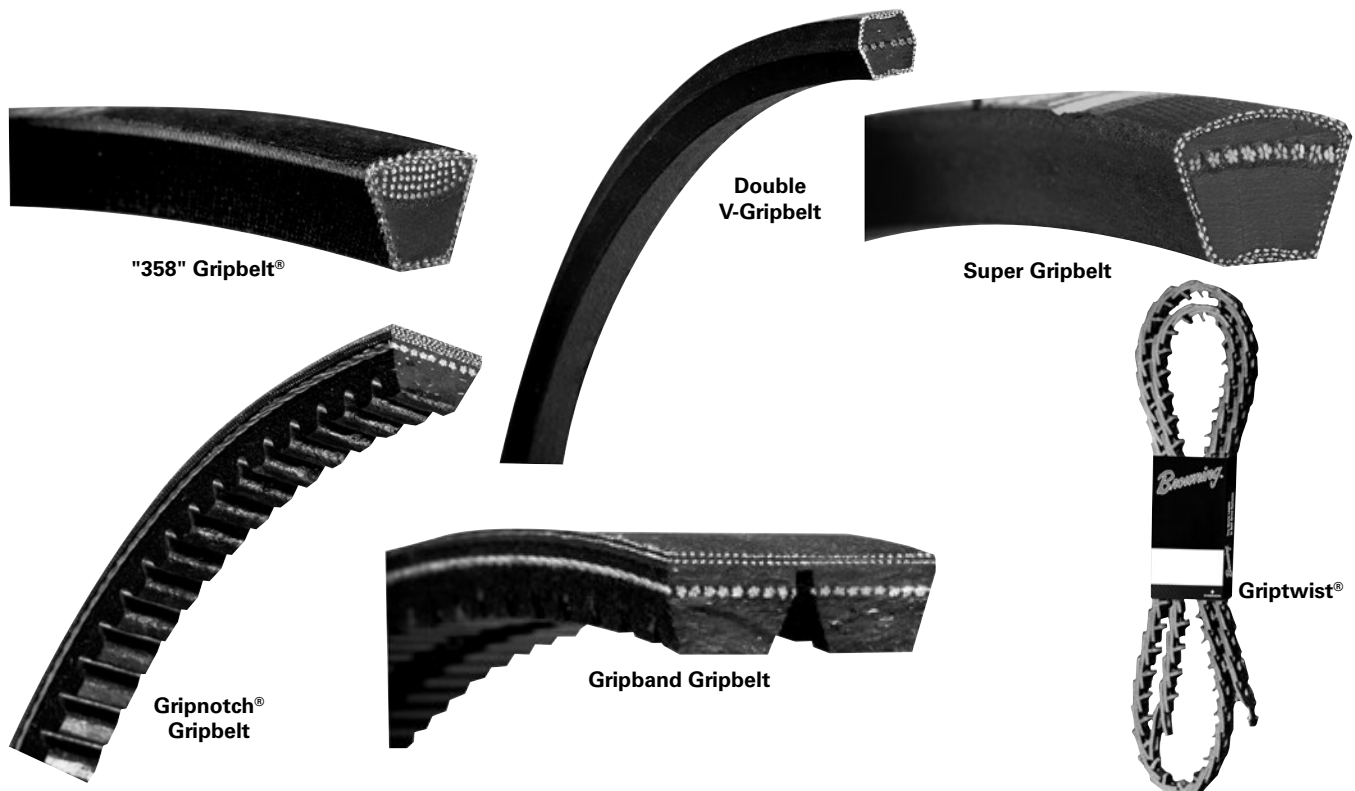

# OEM Specified —

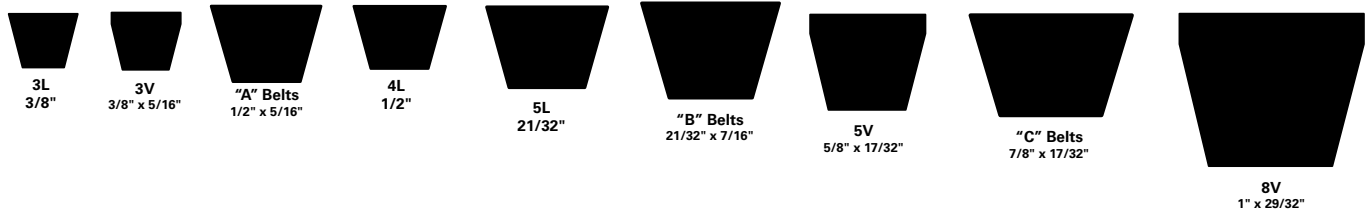

## BROWNING® BELTS ARE DESIGNED TO ENHANCE PERFORMANCE AND INCREASE HP CAPACITY IN SHORTER CENTER DRIVES

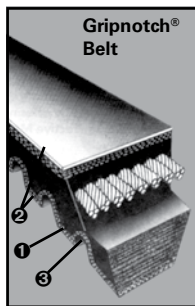
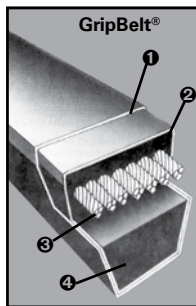

### Before we talk about “Avoiding Problems” and “Solving Problems”, let’s take a brief look at how V-belts are constructed.

There are basically two types of construction. One has a fabric wrapper (or jacket) surrounding it; the other – usually rated higher in horsepower – is made in a raw edged, cogged construction.

#### GripBelt® V-Belts

1. More flexible than V-Belts with multi-layer fabric designs for better belt wrap around sheaves, especially with sub-minimal pitch diameters.
2. Improved Cord Adhesion
3. Improved Flexibility Cords
4. Improved SBR Compounds

#### Gripnotch® V-Belts

1. EPDM Material
  - Operating Temperatures: -60 F to +250 F
2. Ground Form
  - Reduced vibration increases belt and bearing life.
3. Fabric Top and Bottom
  - Competitors typically offer fabric on the top only
4. Wider Notch Spacing
  - Increases rigidity and stability. Reduces stress on the cord line and increases belt life.



# — Contractor Preferred



# Browning®

## Fixed and Variable Pitch

- EDGE™ Selection Program
- B5V®, VP, and MVP® sheaves
- Browning SplitTaper® and Q-D® bushing system
- Performance V-belts
- Millions of drive combinations
- Among the broadest catalog offerings in the industry in v-belt sheaves and belts.

# OEM Specified —

## **BROWNING SPLIT TAPER® BUSHING...**

- Solid flange to maintain concentric bores
- 3/4" taper per foot – self locking
- Double-split barrel for positive clamping
- External key on most sizes for positive drive and greater torque carrying capabilities
- Available in inch, metric and spline bores. Bore ranges from 3/8" to 7 7/16"

## **Mounted Ball Bearings**

- Available in a variety of housing configurations including pillow block, two-bolt flange, four-bolt flange and more
- Air Handling "AH" Option from stock includes:
  - AH Housing Fit: Air Handling "AH" ball bearings are manufactured with a controlled housing fit that allows the bearing to properly self-align when mounted on lightweight frames commonly found on air handling equipment.
  - Noise Test: All Air Handling "AH" bearings must pass a two stage noise testing verification for quiet operation to meet the noise level standards of the air handling industry.

— **Contractor Preferred**

### V-Belts

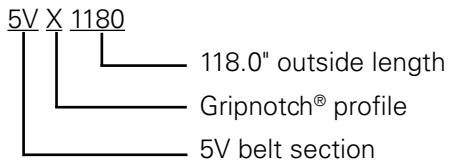
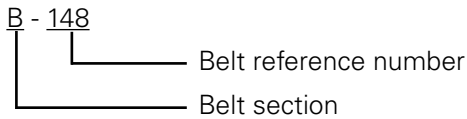
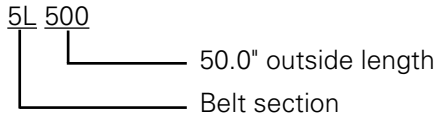

### Bearings

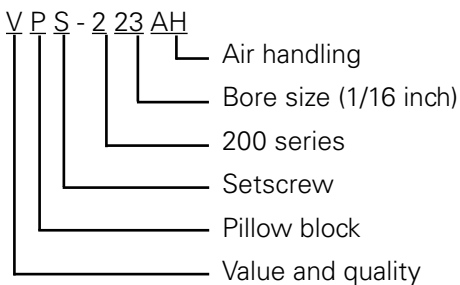
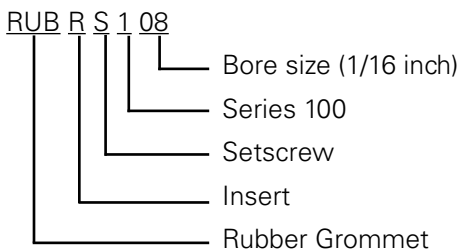

### Sheaves

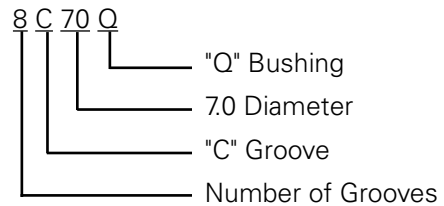
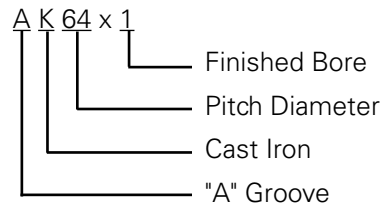
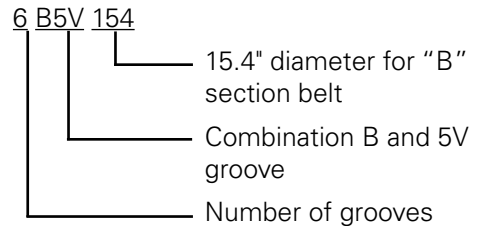
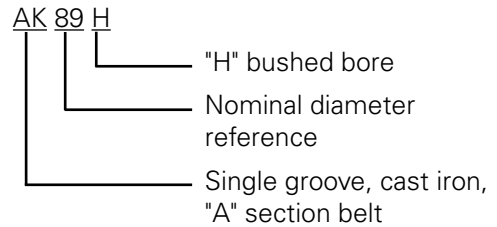
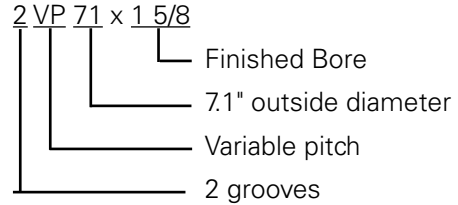

# A20 - D660

## SUPER GRIPBELT® BELTS

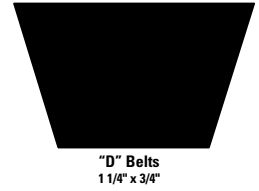
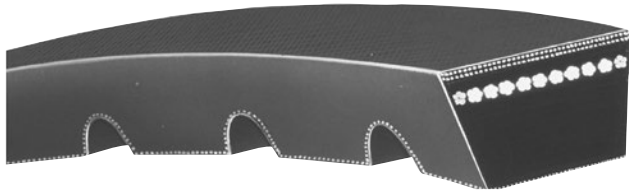

Table No.1

## SUPER GRIPBELT BELTS ARE STATIC CONDUCTING

Belt No.	Length (in.)		Wt. Lbs.	Belt No.	Length (in.)		Wt. Lbs.	Belt No.	Length (in.)		Wt. Lbs.	Belt No.	Length (in.)		Wt. Lbs.
	Outside	Pitch			Outside	Pitch			Outside	Pitch			Outside	Pitch	
A20	22.2	21.3	.2	A91	93.2	92.3	.6	B74	77.0	75.8	.8	C68	72.2	70.9	1.3
A21	23.2	22.3	.2	A92	94.2	93.3	.6	B75	78.0	76.8	.8	C72	76.2	74.9	1.4
A22	24.2	23.3	.2	A93	95.2	94.3	.6	B76	79.0	77.8	.8	C75	79.2	77.9	1.4
A23	25.2	24.3	.2	A94	96.2	95.3	.6	B77	80.0	78.8	.8	C78	82.2	80.9	1.5
A24	26.2	25.3	.2	A95	97.2	96.3	.6	B78	81.0	79.8	.8	C81	85.2	83.9	1.6
A25	27.2	26.3	.2	A96	98.2	97.3	.7	B79	82.0	80.8	.8	C85	89.2	87.9	1.6
A26	28.2	27.3	.2	A97	99.2	98.3	.7	B80	83.0	81.8	.9	C90	94.2	92.9	1.7
A27	29.2	28.3	.2	A98	100.2	99.3	.7	B81	84.0	82.8	.9	C96	100.2	98.9	1.8
A28	30.2	29.3	.2	A100	102.2	101.3	.7	B82	85.0	83.8	.9	C97	101.2	99.9	1.8
A29	31.2	30.3	.2	A103	105.2	104.3	.7	B83	86.0	84.8	.9	C99	103.2	101.9	1.9
A30	32.2	31.3	.2	A105	107.2	106.3	.7	B84	87.0	85.8	.9	C100	104.2	102.9	1.9
A31	33.2	32.3	.2	A110	112.2	111.3	.8	B85	88.0	86.8	.9	C101	105.2	103.9	1.9
A32	34.2	33.3	.2	A112	114.2	113.3	.8	B86	89.0	87.8	1.0	C105	109.2	107.9	2.0
A33	35.2	34.3	.2	A120	122.2	121.3	.8	B87	90.0	88.8	1.0	C108	112.2	110.9	2.0
A34	36.2	35.3	.2	A128	130.2	129.3	.9	B88	91.0	89.8	1.0	C109	113.2	111.9	2.0
A35	37.2	36.3	.2	A136	138.2	137.3	.9	B89	92.0	90.8	1.0	C111	115.2	113.9	2.1
A36	38.2	37.3	.3	A144	146.2	145.3	1.0	B90	93.0	91.8	1.0	C112	116.2	114.9	2.1
A37	39.2	38.3	.3	A158	160.2	159.3	1.1	B91	94.0	92.8	1.0	C115	119.2	117.9	2.1
A38	40.2	39.3	.3	A173	175.2	174.3	1.2	B92	95.0	93.8	1.0	C120	124.2	122.9	2.3
A39	41.2	40.3	.3	A180	182.2	181.3	1.2	B93	96.0	94.8	1.0	C122	126.2	124.9	2.3
A40	42.2	41.3	.3	B23	26.0	24.8	.3	B94	97.0	95.8	1.0	C124	128.2	126.9	2.4
A41	43.2	42.3	.3	B24	27.0	25.8	.3	B95	98.0	96.8	1.0	C128	132.2	130.9	2.4
A42	44.2	43.3	.3	B25	28.0	26.8	.3	B96	99.0	97.8	1.1	C136	140.2	138.9	2.6
A43	45.2	44.3	.3	B26	29.0	27.8	.3	B97	100.0	98.8	1.1	C144	148.2	146.9	2.8
A44	46.2	45.3	.3	B27	30.0	28.8	.3	B98	101.0	99.8	1.1	C148	152.2	150.9	2.8
A45	47.2	46.3	.3	B28	31.0	29.8	.3	B99	102.0	100.8	1.1	C150	154.2	152.9	2.9
A46	48.2	47.3	.3	B29	32.0	30.8	.3	B100	103.0	101.8	1.1	C158	162.2	160.9	3.0
A47	49.2	48.3	.3	B30	33.0	31.8	.3	B101	104.0	102.8	1.1	C162	166.2	164.9	3.1
A48	50.2	49.3	.3	B31	34.0	32.8	.3	B103	106.0	104.8	1.1	C166	170.2	168.9	3.0
A49	51.2	50.3	.4	B32	35.0	33.8	.3	B105	108.0	106.8	1.1	C173	177.2	175.9	3.3
A50	52.2	51.3	.4	B33	36.0	34.8	.4	B106	109.0	107.8	1.1	C180	184.2	182.9	3.4
A51	53.2	52.3	.4	B34	37.0	35.8	.4	B108	111.0	109.8	1.2	C195	199.2	197.9	3.7
A52	54.2	53.3	.4	B35	38.0	36.8	.4	B110	113.0	111.8	1.2	C210	214.2	212.9	4.0
A53	55.2	54.3	.4	B36	39.0	37.8	.4	B111	114.0	112.8	1.2	C225	227.2	225.9	4.3
A54	56.2	55.3	.4	B37	40.0	38.8	.4	B112	115.0	113.8	1.2	C240	242.2	240.9	4.6
A55	57.2	56.3	.4	B38	41.0	39.8	.4	B114	117.0	115.8	1.3	C255	257.2	255.9	4.9
A56	58.2	57.3	.4	B39	42.0	40.8	.4	B116	119.0	117.8	1.3	C270	272.2	270.9	5.2
A57	59.2	58.3	.4	B40	43.0	41.8	.5	B117	121.0	119.8	1.3	C285	287.2	285.9	5.4
A58	60.2	59.3	.4	B41	44.0	42.8	.5	B120	123.0	121.8	1.3	C300	302.2	300.9	5.7
A59	61.2	60.3	.4	B42	45.0	43.8	.5	B123	126.0	124.8	1.3	C315	317.2	315.9	6.0
A60	62.2	61.3	.4	B43	46.0	44.8	.5	B124	127.0	125.8	1.3	C330	332.2	330.9	6.3
A61	63.2	62.3	.4	B44	47.0	45.8	.5	B126	129.0	127.8	1.4	C345	347.2	345.9	6.6
A62	64.2	63.3	.4	B45	48.0	46.8	.5	B128	131.0	129.8	1.4	C360	362.2	360.9	6.9
A63	65.2	64.3	.4	B46	49.0	47.8	.5	B133	136.0	134.8	1.5	C390	392.2	390.9	7.5
A64	66.2	65.3	.4	B47	50.0	48.8	.5	B136	139.0	137.8	1.5	C420	422.2	420.9	8.0
A65	67.2	66.3	.5	B48	51.0	49.8	.5	B138	141.0	139.8	1.6	D120	125.2	123.3	4.0
A66	68.2	67.3	.5	B49	52.0	50.8	.6	B140	143.0	141.8	1.6	D128	133.2	131.3	4.4
A67	69.2	68.3	.5	B50	53.0	51.8	.6	B144	147.0	145.8	1.6	D144	149.2	147.3	5.0
A68	70.2	69.3	.5	B51	54.0	52.8	.6	B148	151.0	149.8	1.6	D158	163.2	161.3	5.3
A69	71.2	70.3	.5	B52	55.0	53.8	.6	B150	153.0	151.8	1.6	D162	167.2	165.3	5.5
A70	72.2	71.3	.5	B53	56.0	54.8	.6	B154	157.0	155.8	1.7	D173	178.2	176.3	5.8
A71	73.2	72.3	.5	B54	57.0	55.8	.6	B158	161.0	159.8	1.7	D180	185.2	183.3	6.0
A72	74.2	73.3	.5	B55	58.0	56.8	.6	B162	165.0	163.8	1.7	D195	200.2	198.3	6.3
A73	75.2	74.3	.5	B56	59.0	57.8	.6	B173	176.0	174.8	1.9	D210	215.2	213.3	6.8
A74	76.2	75.3	.5	B57	60.0	58.8	.7	B180	183.0	181.8	1.9	D225	227.2	225.8	7.1
A75	77.2	76.3	.5	B58	61.0	59.8	.7	B190	193.0	191.8	2.0	D240	242.2	240.8	7.7
A76	78.2	77.3	.5	B59	62.0	60.8	.7	B191	194.0	192.2	2.0	D255	257.2	255.8	8.1
A77	79.2	78.3	.5	B60	63.0	61.8	.7	B195	198.0	196.8	2.0	D270	272.2	270.8	8.9
A78	80.2	79.3	.5	B61	64.0	62.8	.7	B205	208.0	206.9	2.2	D285	287.2	285.8	9.8
A79	81.2	80.3	.5	B62	65.0	63.8	.7	B210	213.0	211.8	2.3	D300	302.2	300.8	10.5
A80	82.2	81.3	.5	B63	66.0	64.8	.7	B225	226.5	225.3	2.5	D315	317.2	315.8	10.8
A81	83.3	82.3	.5	B64	67.0	65.8	.7	B240	241.5	240.3	2.6	D330	332.2	330.8	10.6
A82	84.2	83.3	.6	B65	68.0	66.8	.7	B255	256.5	255.3	2.8	D345	347.2	345.8	11.7
A83	85.2	84.3	.6	B66	69.0	67.8	.7	B270	271.5	270.3	2.9	D360	362.2	360.8	11.5
A84	86.2	85.3	.6	B67	70.0	68.8	.7	B285	286.5	285.3	3.1	D390	392.2	390.8	12.4
A85	87.2	86.3	.6	B68	71.0	69.8	.7	B300	301.5	300.3	3.2	D420	422.2	420.8	13.4
A86	88.2	87.3	.6	B69	72.0	70.8	.8	B315	316.5	315.3	3.4	D450	452.2	450.8	16.3
A87	89.2	88.3	.6	B70	73.0	71.8	.8	B360	361.5	360.3	4.0	D480	482.2	480.8	15.8
A88	90.2	89.3	.6	B71	74.0	72.8	.8	C51	55.2	53.9	1.0	D540	542.2	540.8	19.9
A89	91.2	90.3	.6	B72	75.0	73.8	.8	C55	59.2	57.9	1.1	D600	602.2	600.8	21.6
A90	92.2	91.3	.6	B73	76.0	74.8	.8	C60	64.2	62.9	1.2	D660	662.2	660.8	28.8

## GRIPNOTCH® BELTS



- EPDM Material
- Operating Temps -60d F to +250d F
- Precision molded raw edge construction
- More horsepower in less space compared to "wrapped" belts
- Notches are molded extra deep
- Oil and heat resistant
- Static conducting

Table No.1

Belt No.	Length (in.)		Wt. Lbs.	Belt No.	Length (in.)		Wt. Lbs.	Belt No.	Length (in.)		Wt. Lbs.	Belt No.	Length (in.)		Wt. Lbs.
	Outside	Pitch			Outside	Pitch			Outside	Pitch			Outside	Pitch	
AX20	22.2	21.3	.2	AX77	79.2	78.3	.5	BX55	58.0	56.8	.6	BX128	131.0	129.8	1.5
AX21	23.2	22.3	.2	AX78	80.2	79.3	.5	BX56	59.0	57.8	.6	BX133	136.0	134.8	1.5
AX22	24.2	23.3	.2	AX79	81.2	80.3	.5	BX57	60.0	58.8	.6	BX136	139.0	137.8	1.6
AX23	25.2	24.3	.2	AX80	82.2	81.3	.5	BX58	61.0	59.8	.6	BX140	143.0	141.8	1.6
AX24	26.2	25.3	.2	AX81	83.2	82.3	.5	BX59	62.0	60.8	.7	BX144	147.0	145.8	1.7
AX25	27.2	26.3	.2	AX82	84.2	83.3	.5	BX60	63.0	61.8	.7	BX148	151.0	149.8	1.7
AX26	28.2	27.3	.2	AX83	85.2	84.3	.5	BX61	64.0	62.8	.7	BX150	153.0	151.8	1.8
AX27	29.2	28.3	.2	AX84	86.2	85.3	.5	BX62	65.0	63.8	.7	BX154	157.0	155.8	1.8
AX28	30.2	29.3	.2	AX85	87.2	86.3	.6	BX63	66.0	64.8	.7	BX158	161.0	159.8	1.8
AX29	31.2	30.3	.2	AX86	88.2	87.3	.6	BX64	67.0	65.8	.7	BX162	165.0	163.8	1.9
AX30	32.2	31.3	.2	AX87	89.2	88.3	.6	BX65	68.0	66.8	.8	BX173	176.0	174.8	2.0
AX31	33.2	32.3	.2	AX88	90.2	89.3	.6	BX66	69.0	67.8	.8	BX180	183.0	181.8	2.1
AX32	34.2	33.3	.2	AX89	91.2	90.3	.6	BX67	70.0	68.8	.8	BX191	194.0	192.8	2.2
AX33	35.2	34.3	.2	AX90	92.2	91.3	.6	BX68	71.0	69.8	.8	BX195	198.0	196.8	2.3
AX34	36.2	35.3	.2	AX91	93.2	92.3	.6	BX69	72.0	70.8	.8	BX210	213.0	211.8	2.5
AX35	37.2	36.3	.2	AX92	94.2	93.3	.6	BX70	73.0	71.8	.8	BX225	228.0	226.8	2.7
AX36	38.2	37.3	.3	AX93	95.2	94.3	.6	BX71	74.0	72.8	.8	BX240	241.5	240.3	2.8
AX37	39.2	38.3	.3	AX94	96.2	95.3	.6	BX72	75.0	73.8	.8	BX255	256.5	255.3	3.0
AX38	40.2	39.3	.3	AX95	97.2	96.3	.6	BX73	76.0	74.8	.8	BX270	271.5	270.3	3.2
AX39	41.2	40.3	.3	AX96	98.2	97.3	.7	BX74	77.0	75.8	.8	BX300	301.5	300.3	3.6
AX40	42.2	41.3	.3	AX97	99.2	98.3	.7	BX75	78.0	76.8	.9	CX51	55.2	53.9	1.0
AX41	43.2	42.3	.3	AX98	100.2	99.3	.7	BX76	78.0	77.8	.9	CX55	59.2	57.9	1.1
AX42	44.2	43.3	.3	AX100	102.2	101.3	.7	BX77	80.0	78.8	.9	CX60	64.2	62.9	1.2
AX43	45.2	44.3	.3	AX105	107.2	106.3	.7	BX78	81.0	79.8	.9	CX68	72.2	70.9	1.4
AX44	46.2	45.3	.3	AX110	112.2	111.3	.8	BX79	82.0	80.8	.9	CX72	76.2	74.9	1.4
AX45	47.2	46.3	.3	AX112	114.2	113.3	.8	BX80	83.0	81.8	.9	CX75	79.2	77.9	1.5
AX46	48.2	47.3	.3	AX120	122.2	121.3	.8	BX81	84.0	82.8	.9	CX78	82.2	80.9	1.6
AX47	49.2	48.3	.3	AX128	130.2	129.3	.9	BX82	85.0	83.8	.9	CX81	85.2	83.9	1.6
AX48	50.2	49.3	.3	AX144	146.2	145.3	1.0	BX83	86.0	84.8	1.0	CX85	89.2	87.9	1.7
AX49	51.2	50.3	.4	BX27	30.0	28.8	.4	BX84	87.0	85.8	1.0	CX90	94.2	92.9	1.8
AX50	52.2	51.3	.4	BX28	31.0	29.8	.4	BX85	88.0	86.8	1.0	CX96	100.2	98.9	1.9
AX51	53.2	52.3	.4	BX29	32.0	30.8	.4	BX86	89.0	87.8	1.0	CX100	104.2	102.2	2.0
AX52	54.2	53.3	.4	BX30	33.0	31.8	.4	BX87	90.0	88.8	1.0	CX101	105.2	103.9	2.0
AX53	55.2	54.3	.4	BX31	34.0	32.8	.4	BX88	91.0	89.8	1.0	CX105	109.2	107.9	2.0
AX54	56.2	55.3	.4	BX32	35.0	33.8	.4	BX89	92.0	90.8	1.0	CX109	113.2	111.9	2.1
AX55	57.2	56.3	.4	BX33	36.0	34.8	.4	BX90	93.0	91.8	1.1	CX112	116.2	114.9	2.2
AX56	58.2	57.3	.4	BX34	37.0	35.8	.4	BX91	94.0	92.8	1.1	CX115	119.2	117.9	2.3
AX57	59.2	58.3	.4	BX35	38.0	36.8	.4	BX92	95.0	93.8	1.1	CX120	124.2	122.9	2.4
AX58	60.2	59.3	.4	BX36	39.0	37.8	.4	BX94	97.0	95.8	1.1	CX124	128.2	126.9	2.5
AX59	61.2	60.3	.4	BX37	40.0	38.8	.4	BX95	98.0	96.8	1.1	CX128	132.2	130.9	2.6
AX60	62.2	61.3	.4	BX38	41.0	39.8	.4	BX96	99.0	97.8	1.1	CX136	140.2	138.9	2.7
AX61	63.2	62.3	.4	BX39	42.0	40.8	.5	BX97	100.0	98.8	1.1	CX144	148.2	146.9	2.9
AX62	64.2	63.3	.4	BX40	43.0	41.8	.5	BX98	101.0	99.8	1.1	CX150	154.2	152.9	3.0
AX63	65.2	64.3	.4	BX41	44.0	42.8	.5	BX99	102.0	100.8	1.2	CX158	162.2	160.9	3.0
AX64	66.2	65.3	.4	BX42	45.0	43.8	.5	BX100	103.0	101.8	1.2	CX162	166.2	164.9	3.1
AX65	67.2	66.3	.5	BX43	46.0	44.8	.5	BX103	106.0	104.8	1.2	CX180	184.2	182.9	3.2
AX66	68.2	67.3	.5	BX44	47.0	45.8	.5	BX105	108.0	106.8	1.2	CX195	199.2	197.9	3.5
AX67	69.2	68.3	.5	BX45	48.0	46.8	.5	BX106	109.0	107.8	1.2	CX210	214.2	212.9	4.0
AX68	70.2	69.3	.5	BX46	49.0	47.8	.5	BX108	111.0	109.8	1.3	CX225*	229.2	227.9	4.2
AX69	71.2	70.3	.5	BX47	50.0	48.8	.5	BX112	115.0	113.8	1.3	CX240	242.2	240.9	4.3
AX70	72.2	71.3	.5	BX48	51.0	49.8	.6	BX113	116.0	114.8	1.3	CX255	259.2	257.9	4.6
AX71	73.2	72.3	.5	BX49	52.0	50.8	.6	BX115	118.0	116.8	1.4	CX270	272.2	270.9	5.0
AX72	74.2	73.3	.5	BX50	53.0	51.8	.6	BX116	119.0	117.8	1.4	CX300	304.2	302.9	5.4
AX73	75.2	74.3	.5	BX51	54.0	52.8	.6	BX120	123.0	121.8	1.4	CX330	334.2	332.9	5.9
AX74	76.2	75.3	.5	BX52	55.0	53.8	.6	BX123	126.0	124.8	1.4	CX360	364.2	362.9	6.3
AX75	77.2	76.3	.5	BX53	56.0	54.8	.6	BX124	127.0	125.8	1.4				
AX76	78.2	77.3	.5	BX54	57.0	55.8	.6	BX126	129.0	127.8	1.4				

\* CX225 section belts and longer are SBR fiber loaded material; not EPDM.

# 3GBBX51 - 4GBC300

## GRIPBAND BELTS

- Oil and heat resistant
- Ideal for pulsating loads and long centers
- Static conducting



Table No.1

Stock Sizes

Part No.	Pitch Length (in.)	Wt. Lbs.	Part No.	Pitch Length (in.)	Wt. Lbs.	Part No.	Pitch Length (in.)	Wt. Lbs.	Part No.	Pitch Length (in.)	Wt. Lbs.	Part No.	Pitch Length (in.)	Wt. Lbs.
3GBBX51	52.8	1.8	4GBBX71	72.8	4.4	2GBBX112	113.8	3.4	3GBB210	211.8	9.3	2GBC162	164.9	8.4
3GBBX53	54.8	1.8	2GBBX75	76.8	2.3	3GBBX112	113.8	5.1	4GBB210	211.8	12.4	3GBC162	164.9	12.6
2GBBX55	56.8	1.8	3GBBX75	76.8	3.5	4GBBX112	113.8	6.8	2GBB240	240.3	7.0	4GBC162	164.9	16.8
3GBBX55	56.8	2.7	4GBBX75	76.8	4.6	4GBBX128	129.8	7.8	3GBB240	240.3	10.5	2GBC173	175.9	9.0
2GBBX56	57.8	1.8	3GBBX77	78.8	3.5	2GBBX140	141.8	4.1	4GBB240	240.3	14.0	3GBC173	175.9	13.5
3GBBX56	57.8	2.7	3GBBX79	80.8	3.6	2GBB120	121.8	3.6	2GBCX75	77.9	4.0	4GBC173	175.9	18.0
4GBBX56	57.8	3.6	2GBBX80	81.8	2.4	3GBB120	121.8	5.4	3GBCX75	77.9	6.0	2GBC180	182.9	9.4
3GBBX58	59.8	2.9	2GBBX81	82.8	2.5	4GBB120	121.8	7.2	4GBCX75	77.9	8.0	3GBC180	182.9	14.1
2GBBX60	61.8	1.8	3GBBX81	82.8	3.8	2GBB124	125.8	3.8	2GBCX81	83.9	4.2	4GBC180	182.9	18.8
3GBBX60	61.8	2.7	4GBBX81	82.8	5.0	3GBB124	125.8	5.7	3GBCX81	83.9	6.3	2GBC195	197.9	10.2
4GBBX60	61.8	3.6	2GBBX83	84.8	2.6	4GBB124	125.8	7.6	4GBCX81	83.9	8.4	3GBC195	197.9	15.3
2GBBX62	63.8	1.8	3GBBX83	84.8	3.9	2GBB128	129.8	3.9	2GBCX85	87.9	4.4	4GBC195	197.9	20.4
3GBBX62	63.8	2.7	4GBBX83	84.8	5.2	3GBB128	129.8	5.9	3GBCX85	87.9	6.6	2GBC210	212.9	11.0
4GBBX62	63.8	3.6	2GBBX85	86.8	2.7	4GBB128	129.8	7.8	4GBCX85	87.9	8.8	3GBC210	212.9	16.5
2GBBX63	64.8	2.0	3GBBX85	86.8	4.1	2GBB136	137.8	4.0	2GBCX90	92.9	4.8	4GBC210	212.9	22.0
3GBBX63	64.8	3.0	4GBBX85	86.8	5.4	3GBB136	137.8	6.0	3GBCX90	92.9	7.2	2GBC225	225.9	11.8
4GBBX63	64.8	4.0	2GBBX90	91.8	2.8	4GBB136	137.8	8.0	4GBCX90	92.9	9.6	3GBC225	225.9	17.7
2GBBX64	65.8	2.0	3GBBX90	91.8	4.2	2GBB144	145.8	4.4	2GBCX96	98.9	5.0	4GBC225	225.9	23.6
3GBBX64	65.8	3.0	4GBBX90	91.8	5.6	3GBB144	145.8	6.6	3GBCX96	98.9	7.5	2GBC240	240.9	12.6
4GBBX64	65.8	4.0	5GBBX90	91.8	7.0	4GBB144	145.8	8.8	4GBCX96	98.9	10.0	3GBC240	240.9	18.9
2GBBX65	66.8	2.0	2GBBX93	94.8	2.8	2GBB158	159.8	4.8	2GBCX100	102.9	5.2	4GBC240	240.9	25.2
3GBBX65	66.8	3.0	3GBBX93	94.8	4.2	3GBB158	159.8	7.2	3GBCX100	102.9	7.8	2GBC255	255.9	11.8
4GBBX65	66.8	4.0	4GBBX93	94.8	5.6	4GBB158	159.8	9.6	4GBCX100	102.9	10.4	3GBC255	255.9	17.7
2GBBX66	67.8	2.0	2GBBX97	98.8	3.0	2GBB162	163.8	5.0	2GBCX105	107.9	5.6	4GBC255	255.9	23.6
3GBBX66	67.8	3.0	3GBBX97	98.8	4.5	3GBB162	163.8	7.5	3GBCX105	107.9	8.4	2GBC270	270.9	14.0
4GBBX66	67.8	4.0	4GBBX97	98.8	6.0	4GBB162	163.8	10.0	4GBCX105	107.9	11.2	3GBC270	270.9	21.0
2GBBX67	68.8	2.0	2GBBX100	101.8	3.0	2GBB173	174.8	5.2	2GBCX112	114.9	5.8	4GBC270	270.9	28.0
3GBBX67	68.8	3.0	3GBBX100	101.8	4.5	3GBB173	174.8	7.8	3GBCX112	114.9	8.7	2GBC300	300.9	15.6
2GBBX68	69.8	2.1	4GBBX100	101.8	6.0	4GBB173	174.8	10.4	4GBCX112	114.9	11.6	3GBC300	300.9	23.4
3GBBX68	69.8	3.1	2GBBX103	104.8	3.1	2GBB180	181.8	5.4	4GBC128	130.9	12.8	4GBC300	300.9	31.2
4GBBX68	69.8	4.2	3GBBX103	104.8	4.7	3GBB180	181.8	8.1	2GBC144	146.9	7.6			
2GBBX70	71.8	2.2	4GBBX103	104.8	6.2	4GBB180	181.8	10.8	3GBC144	146.9	11.4			
3GBBX70	71.8	3.3	2GBBX105	106.8	3.2	2GBB195	196.8	5.8	4GBC144	146.9	15.2			
4GBBX70	71.8	4.4	3GBBX105	106.8	4.8	3GBB195	196.8	8.7	2GBC158	160.9	8.2			
2GBBX71	72.8	2.2	4GBBX105	106.8	6.4	4GBB195	196.8	11.6	3GBC158	160.9	12.3			
3GBBX71	72.8	3.3	2GBBX108	109.8	3.3	2GBB210	211.8	6.2	4GBC158	160.9	16.4			

Gripband belts with more ribs are available on special order or combinations of Stock Gripband belts may be ordered in matched sets for drives with more grooves; for example, two matched three rib Gripband belts may be used on a six groove drive.

Horsepower ratings for "X" Gripband belts are the same as appropriate number of Gripnotch® Belts; others same as Super Gripbelt® belts.

Part No. 2GBBX56 means - 2 = Two Ribs  
 GB = Gripband  
 B = Cross Section  
 X = Notched Construction  
 56 = Length Designation

For additional product information, visit [www.regalrexnord.com/Browning](http://www.regalrexnord.com/Browning)

## DOUBLE V GRIPBELT® BELTS

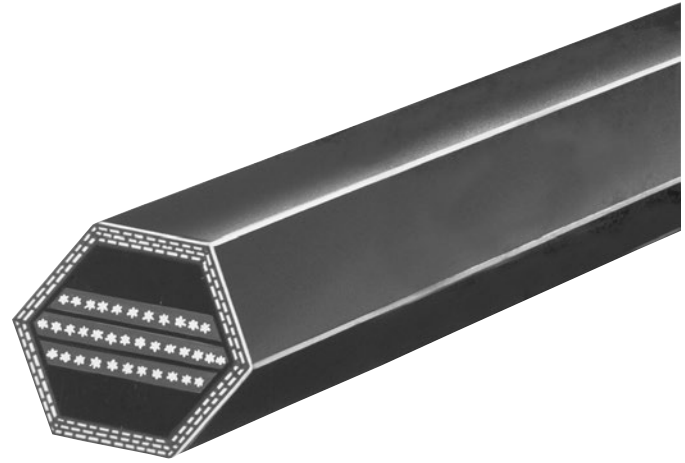

**Table No.1**

Belt No.	Length (in.)		Wt. Lbs.	Belt No.	Length (in.)		Wt. Lbs.	Belt No.	Length (in.)		Wt. Lbs.	Belt No.	Length (in.)		Wt. Lbs.
	Outside	Pitch			Outside	Pitch			Outside	Pitch			Outside	Pitch	
AA51	54.5	53.1	.5	BB81	85.7	83.9	1.1	BB128	132.7	130.9	1.9	CC90	96.2	94.2	2.0
AA55	58.5	57.1	.5	BB83	87.7	85.9	1.2	BB129	133.7	131.9	2.0	CC96	102.2	100.2	2.1
AA60	63.5	62.1	.6	BB85	89.7	87.9	1.2	BB136	140.7	138.9	2.1	CC105	111.2	109.2	2.3
AA68	71.5	70.1	.6	BB90	94.7	92.9	1.3	BB144	148.7	146.9	2.2	CC112	118.2	116.2	2.6
AA75	78.5	77.1	.7	BB93	97.7	95.9	1.3	BB155	159.7	157.9	2.3	CC120	126.2	124.2	2.9
AA80	83.5	82.1	.8	BB94	98.7	96.9	1.4	BB158	162.7	160.9	2.5	CC128	134.2	132.2	3.1
AA85	88.5	87.1	.8	BB97	101.7	99.9	1.4	BB173	177.7	175.9	2.6	CC136	142.2	140.2	3.3
AA90	93.5	92.1	.9	BB103	107.7	105.9	1.5	BB180	184.7	182.9	2.8	CC144	150.2	148.2	3.5
AA96	99.5	98.1	1.0	BB105	109.7	107.9	1.5	BB182	186.7	184.9	2.8	CC158	164.2	162.2	3.9
AA105	108.5	107.1	1.0	BB107	111.7	109.9	1.6	BB190	194.7	192.9	2.9	CC162	168.2	166.2	3.9
AA112	115.5	114.1	1.1	BB108	112.7	110.9	1.6	BB195	199.7	197.9	2.9	CC173	179.2	177.2	4.2
AA120	123.5	122.1	1.2	BB111	115.7	113.9	1.7	BB210	214.7	212.9	3.1	CC180	186.2	184.2	4.4
AA128	131.5	130.1	1.2	BB112	116.7	114.9	1.5	BB226	229.2	227.4	3.4	CC195	201.2	199.2	4.8
BB45	49.7	47.9	.6	BB116	120.7	118.9	1.8	BB228	231.2	229.4	3.4	CC210	216.2	214.2	5.3
BB55	59.7	57.9	.8	BB117	121.7	119.9	1.8	BB240	243.2	241.4	3.6	CC240	242.2	242.2	5.6
BB60	64.7	62.9	.9	BB118	122.7	120.9	1.8	BB270	273.2	271.4	4.0	CC270	274.2	272.2	6.5
BB68	72.7	70.9	.9	BB120	124.7	122.9	1.8	BB300	303.2	301.4	4.6	CC300	304.2	302.2	7.6
BB74	78.7	76.9	1.0	BB123	127.7	125.9	1.9	CC75	81.2	79.2	1.8	CC330	334.2	332.2	7.5
BB75	79.7	77.9	1.0	BB124	128.7	126.9	1.9	CC85	91.2	89.2	1.9	CC360	364.2	362.2	8.1

# 2L120 - 5L1000

## FHP BELTS

- Wrapped construction provides smooth, quiet operation.
- Oil and heat resistant - static conducting.

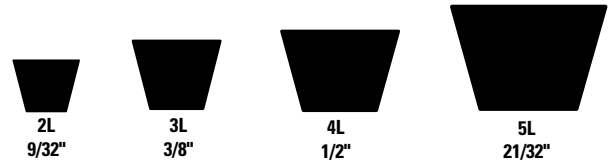

Table No.1

Stock Sizes

Belt No.	Length (in.)		Wt. Lbs.	Belt No.	Length (in.)		Wt. Lbs.	Belt No.	Length (in.)		Wt. Lbs.	Belt No.	Length (in.)		Wt. Lbs.
	Outside	Pitch			Outside	Pitch			Outside	Pitch			Outside	Pitch	
2L150	15	14.6	.04	3L600	60	59.3	.19	4L670	67	66.0	.38	5L450	45	43.8	.38
2L160	16	15.6	.04	3L610	61	60.3	.19	4L680	68	67.0	.38	5L460	46	44.8	.44
2L200	20	19.6	.06	3L620	62	61.3	.19	4L690	69	68.0	.38	5L470	47	45.8	.44
2L220	22	21.6	.06	3L630	63	62.3	.20	4L700	70	69.0	.38	5L480	48	46.8	.44
2L240	24	23.6	.07	4L170	17	16.0	.10	4L710	71	70.0	.38	5L490	49	47.8	.50
2L300	30	29.6	.08	4L180	18	17.0	.10	4L720	72	71.0	.38	5L500	50	48.8	.50
2L310	31	30.6	.08	4L190	19	18.0	.11	4L730	73	72.0	.38	5L510	51	49.8	.50
2L320	32	31.6	.09	4L200	20	19.0	.11	4L740	74	73.0	.38	5L520	52	50.8	.50
2L325	32 1/2	32.1	.09	4L210	21	20.0	.12	4L750	75	74.0	.44	5L530	53	51.8	.50
3L120	12	11.3	.04	4L220	22	21.0	.12	4L760	76	75.0	.44	5L540	54	52.8	.50
3L130	13	12.3	.04	4L225	22 1/2	21.5	.13	4L770	77	76.0	.44	5L550	55	53.8	.50
3L150	15	14.3	.05	4L230	23	22.0	.13	4L780	78	77.0	.44	5L560	56	54.8	.50
3L160	16	15.3	.05	4L240	24	23.0	.13	4L790	79	78.0	.44	5L570	57	55.8	.50
3L170	17	16.3	.05	4L250	25	24.0	.13	4L800	80	79.0	.44	5L580	58	56.8	.50
3L180	18	17.3	.06	4L260	26	25.0	.13	4L810	81	80.0	.44	5L590	59	57.8	.50
3L190	19	18.3	.06	4L270	27	26.0	.13	4L820	82	81.0	.44	5L600	60	58.8	.56
3L200	20	19.3	.06	4L280	28	27.0	.13	4L830	83	82.0	.44	5L610	61	59.8	.56
3L210	21	20.3	.07	4L290	29	28.0	.13	4L840	84	83.0	.44	5L620	62	60.8	.56
3L220	22	21.3	.07	4L300	30	29.0	.13	4L850	85	84.0	.50	5L630	63	61.8	.56
3L230	23	22.3	.07	4L310	31	30.0	.19	4L860	86	85.0	.50	5L640	64	62.8	.63
3L240	24	23.3	.08	4L320	32	31.0	.19	4L870	87	86.0	.50	5L650	65	63.8	.63
3L250	25	24.3	.08	4L330	33	32.0	.19	4L880	88	87.0	.50	5L660	66	64.8	.63
3L260	26	25.3	.08	4L340	34	33.0	.19	4L890	89	88.0	.50	5L670	67	65.8	.63
3L270	27	26.3	.08	4L350	35	34.0	.19	4L900	90	89.0	.50	5L680	68	66.8	.63
3L280	28	27.3	.09	4L360	36	35.0	.19	4L910	91	90.0	.50	5L690	69	67.8	.63
3L290	29	28.3	.09	4L370	37	36.0	.19	4L920	92	91.0	.50	5L700	70	68.8	.69
3L300	30	29.3	.09	4L380	38	37.0	.19	4L930	93	92.0	.50	5L710	71	69.8	.69
3L310	31	30.3	.10	4L390	39	38.0	.25	4L940	94	93.0	.50	5L720	72	70.8	.69
3L320	32	31.3	.10	4L400	40	39.0	.25	4L950	95	94.0	.50	5L730	73	71.8	.69
3L330	33	32.3	.10	4L410	41	40.0	.25	4L960	96	95.0	.50	5L740	74	72.8	.69
3L340	34	33.3	.11	4L415	41 1/2	40.5	.25	4L970	97	96.0	.50	5L750	75	73.8	.69
3L350	35	34.3	.11	4L420	42	41.0	.25	4L980	98	97.0	.56	5L760	76	74.8	.69
3L360	36	35.3	.11	4L430	43	42.0	.25	4L990	99	98.0	.56	5L770	77	75.8	.69
3L370	37	36.3	.12	4L440	44	43.0	.25	4L1000	100	99.0	.56	5L780	78	76.8	.75
3L380	38	37.3	.12	4L450	45	44.0	.25	5L230	23	21.8	.19	5L790	79	77.8	.75
3L390	39	38.3	.12	4L460	46	45.0	.25	5L240	24	22.8	.19	5L800	80	78.8	.75
3L400	40	39.3	.13	4L470	47	46.0	.25	5L250	25	23.8	.19	5L810	81	79.8	.75
3L410	41	40.3	.13	4L480	48	47.0	.25	5L260	26	24.8	.19	5L820	82	80.8	.75
3L420	42	41.3	.13	4L490	49	48.0	.31	5L270	27	25.8	.19	5L830	83	81.8	.75
3L430	43	42.3	.13	4L500	50	49.0	.31	5L280	28	26.8	.19	5L840	84	82.8	.75
3L440	44	43.3	.14	4L510	51	50.0	.31	5L290	29	27.8	.19	5L850	85	83.8	.81
3L450	45	44.3	.14	4L520	52	51.0	.31	5L300	30	28.8	.29	5L860	86	84.8	.81
3L460	46	45.3	.14	4L530	53	52.0	.31	5L310	31	29.8	.25	5L870	87	85.8	.81
3L470	47	46.3	.15	4L540	54	53.0	.31	5L320	32	30.8	.25	5L880	88	86.8	.81
3L480	48	47.3	.15	4L550	55	54.0	.31	5L330	33	31.8	.25	5L890	89	87.8	.81
3L490	49	48.3	.15	4L560	56	55.0	.31	5L340	34	32.8	.25	5L900	90	88.8	.81
3L500	50	49.3	.16	4L570	57	56.0	.31	5L350	35	33.8	.31	5L910	91	89.8	.88
3L510	51	50.3	.16	4L580	58	57.0	.31	5L360	36	34.8	.31	5L920	92	90.8	.88
3L520	52	51.3	.16	4L590	59	58.0	.31	5L370	37	35.8	.31	5L930	93	91.8	.88
3L530	53	52.3	.17	4L600	60	59.0	.31	5L380	38	36.8	.31	5L940	94	92.8	.88
3L540	54	53.3	.17	4L610	61	60.0	.31	5L390	39	37.8	.31	5L950	95	93.8	.88
3L550	55	54.3	.18	4L620	62	61.0	.31	5L400	40	38.8	.31	5L960	96	94.8	.88
3L560	56	55.3	.18	4L630	63	62.0	.31	5L410	41	39.8	.38	5L970	97	95.8	.88
3L570	57	56.3	.18	4L640	64	63.0	.38	5L420	42	40.8	.38	5L980	98	96.8	.94
3L580	58	57.3	.18	4L650	65	64.0	.38	5L430	43	41.8	.38	5L990	99	97.8	.94
3L590	59	58.3	.19	4L660	66	65.0	.38	5L440	44	42.8	.38	5L1000	100	98.8	.94



## 4L, A, AX CROSS REFERENCE GUIDE

4L	A	AX	LENGTH (in.)	4L	A	AX	LENGTH (in.)
4L230	A21	AX21	23.2	4L630	A61	AX61	63.2
4L240	A22	AX22	24.2	4L640	A62	AX62	64.2
4L250	A23	AX23	25.2	4L650	A63	AX63	65.2
4L260	A24	AX24	26.2	4L660	A64	AX64	66.2
4L270	A25	AX25	26.2	4L670	A65	AX65	67.2
4L280	A26	AX26	28.2	4L680	A66	AX66	68.2
4L290	A27	AX27	29.2	4L690	A67	AX67	69.2
4L300	A28	AX28	30.2	4L700	A68	AX68	70.2
4L310	A29	AX29	31.2	4L710	A69	AX69	71.2
4L320	A30	AX30	32.2	4L720	A70	AX70	72.2
4L330	A31	AX31	33.2	4L730	A71	AX71	73.2
4L340	A32	AX32	34.2	4L740	A72	AX72	74.2
4L350	A33	AX33	35.2	4L750	A73	AX73	75.2
4L360	A34	AX34	36.2	4L760	A74	AX74	76.2
4L370	A35	AX35	37.2	4L770	A75	AX75	77.2
4L380	A36	AX36	38.2	4L780	A76	AX76	78.2
4L390	A37	AX37	39.2	4L790	A77	AX77	79.2
4L400	A38	AX38	40.2	4L800	A78	AX78	80.2
4L410	A39	AX39	41.2	4L810	A79	AX79	81.2
4L420	A40	AX40	42.2	4L820	A80	AX80	82.2
4L430	A41	AX41	43.0	4L830	A81	AX81	83.2
4L440	A42	AX42	44.2	4L840	A82	AX82	84.2
4L450	A43	AX43	45.2	4L850	A83	AX83	85.2
4L460	A44	AX44	46.2	4L860	A84	AX84	86.2
4L470	A45	AX45	47.2	4L870	A85	AX85	87.2
4L480	A46	AX46	48.8	4L880	A86	AX86	88.2
4L490	A47	AX47	49.2	4L890	A87	AX87	89.2
4L500	A48	AX48	50.2	4L900	A88	AX88	90.2
4L510	A49	AX49	51.2	4L910	A89	AX89	91.2
4L520	A50	AX50	52.2	4L920	A90	AX90	92.2
4L530	A51	AX51	53.2	4L930	A91	AX91	93.2
4L540	A52	AX52	54.2	4L940	A92	AX92	94.2
4L550	A53	AX53	55.2	4L950	A93	AX93	95.2
4L560	A54	AX54	56.2	4L960	A94	AX94	96.2
4L570	A55	AX55	57.2	4L970	A95	AX95	97.2
4L580	A56	AX56	58.2	4L980	A96	AX96	98.2
4L590	A57	AX57	59.2	4L990	A97	AX97	99.2
4L600	A58	AX58	60.2	4L1000	A98	AX98	100.2
4L610	A59	AX59	61.2	-	A99	AX99	101.2
4L620	A60	AX60	62.2	-	A100	AX100	102.2

Substitutions can be made based on this chart for 4L or 5L FHP belt sizes to "A/B" Super Gripbelt® or "AX/BX" Griponotch® belts. Substitutions cannot be made from an "A/B" Super Gripbelt® or "AX/BX" Griponotch® belts to 4L or 5L belts.

**Examples:**

A 4L230 can be substituted with an A21 or AX21 but, you cannot substitute a A21 or AX21 with a 4L230.  
 A 5L310 can be substituted with a B28 or BX28 but, you cannot substitute a B28 or BX28 with 5L310.



## 5L, B, BX CROSS REFERENCE GUIDE

5L	B	BX	LENGTH (in.)	5L	B	BX	LENGTH (in.)
5L310	B28	BX28	31.0	5L680	B65	BX65	68.0
5L320	B29	BX29	32.0	5L690	B66	BX66	69.0
5L330	B30	BX30	33.0	5L700	B67	BX67	70.0
5L340	B31	BX31	34.0	5L710	B68	BX68	71.0
5L350	B32	BX32	35.0	5L720	B69	BX69	72.0
5L360	B33	BX33	36.0	5L730	B70	BX70	73.0
5L370	B34	BX34	37.0	5L740	B71	BX71	74.0
5L380	B35	BX35	38.0	5L750	B72	BX72	75.0
5L390	B36	BX36	39.0	5L760	B73	BX73	76.0
5L400	B37	BX37	40.0	5L770	B74	BX74	77.0
5L410	B38	BX38	41.0	5L780	B75	BX75	78.0
5L420	B39	BX39	42.0	5L790	B76	BX76	79.0
5L430	B40	BX40	43.0	5L800	B77	BX77	80.0
5L440	B41	BX41	44.0	5L810	B78	BX78	81.0
5L450	B42	BX42	45.0	5L820	B79	BX79	82.0
5L460	B43	BX43	46.0	5L830	B80	BX80	83.0
5L470	B44	BX44	47.0	5L840	B81	BX81	84.0
5L480	B45	BX45	48.0	5L850	B82	BX82	85.0
5L490	B46	BX46	49.0	5L860	B83	BX83	86.0
5L500	B47	BX47	50.0	5L870	B84	BX84	87.0
5L510	B48	BX48	51.0	5L880	B85	BX85	88.0
5L520	B49	BX49	52.0	5L890	B86	BX86	89.0
5L530	B50	BX50	53.0	5L900	B87	BX87	90.0
5L540	B51	BX51	54.0	5L910	B88	BX88	91.0
5L550	B52	BX52	55.0	5L920	B89	BX89	92.0
5L560	B53	BX53	56.0	5L930	B90	BX90	93.0
5L570	B54	BX54	57.0	5L940	B91	BX91	94.0
5L580	B55	BX55	58.0	5L950	B92	BX92	95.0
5L590	B56	BX56	59.0	5L960	B93	BX93	96.0
5L600	B57	BX57	60.0	5L970	B94	BX94	97.0
5L610	B58	BX58	61.0	5L980	B95	BX95	98.0
5L620	B59	BX59	62.0	5L990	B96	BX96	99.0
5L630	B60	BX60	63.0	5L1000	B97	BX97	100.0
5L640	B61	BX61	64.0	-	B98	BX98	101.0
5L650	B62	BX62	65.0	-	B99	BX99	102.0
5L660	B63	BX63	66.0	-	B100	BX100	103.0
5L670	B64	BX64	67.0	-			

Substitutions can be made based on this chart for 4L or 5L FHP belt sizes to "A/B" Super Gripbelt® or "AX/BX" Griponotch® belts. Substitutions cannot be made from an "A/B" Super Gripbelt® or "AX/BX" Griponotch® belts to 4L or 5L belts.

**Examples:**

A 4L230 can be substituted with an A21 or AX21 but, you cannot substitute a A21 or AX21 with a 4L230.  
 A 5L310 can be substituted with a B28 or BX28 but, you cannot substitute a B28 or BX28 with 5L310.

### "358" GRIPBELT® AND GRIPNOTCH® BELTS

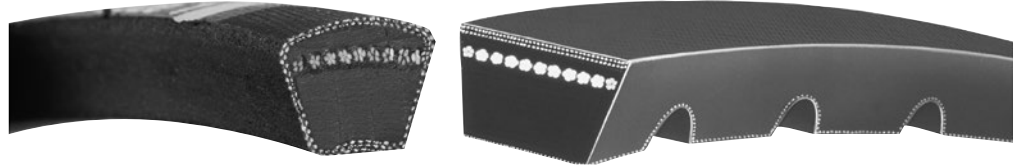

- Oil and heat resistant
- Static conducting
- Gripnotch are EPDM Rubber Temp Range -60 F to 250 F

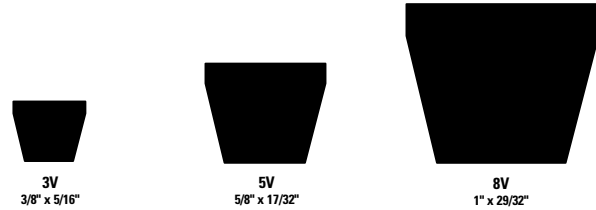

3V  
3/8" x 5/16"

5V  
5/8" x 17/32"

8V  
1" x 29/32"

Table No.1

### Specifications

Part No.	Outside Length (in.)	Wt. Lbs.	Part No.	Outside Length (in.)	Wt. Lbs.	Part No.	Outside Length (in.)	Wt. Lbs.
3VX250	25.0	.1	5VX590	59.0	.6	5V2120	212.0	
3VX265	26.5	.1	5VX600	60.0	.7	5V2240	224.0	2.6
3VX280	28.0	.1	5VX610	61.0	.7	5V2360	236.0	2.8
3VX300	30.0	.1	5VX630	63.0	.7	5V2500	250.0	2.9
3VX315	31.5	.1	5VX650	65.0	.7	5V2650	265.0	3.2
3VX335	33.5	.1	5VX660	66.0	.8	5V2800	280.0	3.3
3VX355	35.5	.2	5VX670	67.0	.8	5V3000	300.0	3.6
3VX375	37.5	.2	5VX680	68.0	.8	5V3150	315.0	3.9
3VX400	40.0	.2	5VX690	69.0	.8	5V3350	335.0	4.0
3VX425	42.5	.2	5VX710	71.0	.8	5V3550	355.0	4.3
3VX450	45.0	.2	5VX730	73.0	.8	8V1000	100.0	3.3
3VX475	47.5	.2	5VX740	74.0	.8	8V1120	112.0	3.6
3VX500	50.0	.2	5VX750	75.0	.8	8V1180	118.0	3.8
3VX530	53.0	.2	5VX780	78.0	.8	8V1250	125.0	3.9
3VX560	56.0	.2	5VX800	80.0	.9	8V1400	140.0	4.5
3VX600	60.0	.3	5VX810	81.0	.9	8V1500	150.0	4.8
3VX630	63.0	.3	5VX830	83.0	.9	8V1600	160.0	5.1
3VX670	67.0	.3	5VX840	84.0	.9	8V1700	170.0	5.6
3VX710	71.0	.3	5VX850	85.0	.9	8V1800	180.0	6.0
3VX750	75.0	.3	5VX860	86.0	.9	8V1900	190.0	6.3
3VX800	80.0	.4	5VX880	88.0	.9	8V2000	200.0	6.5
3VX850	85.0	.4	5VX900	90.0	1.0	8V2120	212.0	6.9
3VX900	90.0	.4	5VX930	93.0	1.0	8V2240	224.0	7.2
3VX950	95.0	.4	5VX950	95.0	1.0	8V2360	236.0	7.6
3VX1000	100.0	.4	5VX960	96.0	1.0	8V2500	250.0	8.0
3VX1060	106.0	.4	5VX1000	100.0	1.1	8V2650	265.0	8.5
3VX1120	112.0	.5	5VX1030	103.0	1.1	8V2800	280.0	8.9
3VX1180	118.0	.5	5VX1060	106.0	1.2	8V3000	300.0	9.6
3VX1250	125.0	.6	5VX1080	108.0	1.2	8V3150	315.0	10.3
3VX1320	132.0	.6	5VX1120	112.0	1.3	8V3350	335.0	11.4
3VX1400	140.0	.6	5VX1150	115.0	1.3	8V3550	355.0	12.4
5VX450	45.0	.4	5VX1180	118.0	1.4	8V4000	400.0	13.0
5VX470	47.0	.5	5VX1230	123.0	1.4	8V4500	450.0	14.4
5VX490	49.0	.5	5VX1250	125.0	1.4			
5VX500	50.0	.6	5VX1320	132.0	1.5			
5VX510	51.0	.6	5VX1400	140.0	1.6			
5VX530	53.0	.6	5VX1500	150.0	1.8			
5VX540	54.0	.6	5VX1600	160.0	1.8			
5VX550	55.0	.6	5VX1700	170.0	2.0			
5VX560	56.0	.6	5VX1800	180.0	2.1			
5VX570	57.0	.6	5VX1900	190.0	2.3			
5VX580	58.0	.6	5VX2000	200.0	2.4			

Belts with "X" in Part Number are Gripnotch Belts.

# 2GB3VX450 - 4GB5V3000

## "358" GRIPBAND® BELTS

### Multiple V-Belts in Single Unit Construction

- Oil and heat resistant
- Ideal for pulsating loads and long centers

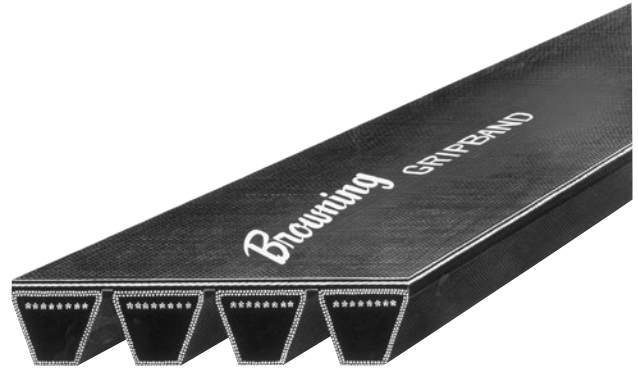

Table No.1

Stock Sizes

Part No.	Outside Length (in.)	Wt. Lbs.	Part No.	Outside Length (in.)	Wt. Lbs.	Part No.	Outside Length (in.)	Wt. Lbs.	Part No.	Outside Length (in.)	Wt. Lbs.	Part No.	Outside Length (in.)	Wt. Lbs.
2GB3VX450	45.0	.6	3GB3VX800	80.0	1.5	4GB3V1400▲	140.0	3.6	4GB5V1120	112.0	7.2	4GB5V1800	180.0	12.0
3GB3VX450	45.0	.9	4GB3VX800	80.0	2.0	2GB5VX670	67.0	2.2	4GB5VX1180	118.0	7.6	2GB5V1900	190.0	6.4
4GB3VX450	45.0	1.2	2GB3VX850	85.0	1.2	3GB5VX670	67.0	3.3	3GB3VX1250	125.0	2.4	3GB5V1900	190.0	9.6
2GB3VX475	47.5	.6	3GB3VX850	85.0	1.8	4GB5VX670	67.0	4.4	3GB5VX1250	125.0	6.0	4GB5V1900	190.0	12.8
3GB3VX475	47.5	.9	4GB3VX850	85.0	2.4	2GB5VX710	71.0	2.4	5GB5V1600	160.0	12.5	2GB5V2000	200.0	6.6
4GB3VX475	47.5	1.2	2GB3VX900	90.0	1.2	3GB5VX710	71.0	3.6	2GB5V1180	118.0	3.8	3GB5V2000	200.0	9.9
2GB3VX500	50.0	.6	3GB3VX900	90.0	1.8	4GB5VX710	71.0	4.8	3GB5V1180	118.0	5.7	4GB5V2000	200.0	13.2
3GB3VX500	50.0	.9	4GB3VX900	90.0	2.4	2GB5VX750	75.0	2.6	4GB5V1180	118.0	7.6	2GB5V2120	212.0	7.0
4GB3VX500	50.0	1.2	2GB3VX950	95.0	1.2	3GB5VX750	75.0	3.9	2GB5V1250	125.0	4.0	3GB5V2120	212.0	10.5
2GB3VX530	53.0	.8	3GB3VX950	95.0	1.8	4GB5VX750	75.0	5.2	3GB5V1250	125.0	6.0	4GB5V2120	212.0	14.0
3GB3VX530	53.0	1.2	4GB3VX950	95.0	2.4	2GB5VX800	80.0	2.6	4GB5V1250	125.0	8.0	2GB5V2240	224.0	7.6
4GB3VX530	53.0	1.6	2GB3VX1000	100.0	1.4	3GB5VX800	80.0	3.9	5GB5V1250	125.0	10.0	3GB5V2240	224.0	11.4
2GB3VX560	56.0	.8	3GB3VX1000	100.0	2.1	4GB5VX800	80.0	5.2	2GB5V1320	132.0	4.0	4GB5V2240	224.0	15.2
3GB3VX560	53.0	1.2	4GB3VX1000	100.0	2.8	4GB5VX850	85.0	5.6	3GB5V1320	132.0	6.0	4GB5V2360	236.0	16.0
4GB3VX560	56.0	1.6	2GB3VX1060	106.0	1.4	2GB5VX900	90.0	3.0	4GB5V1320	132.0	8.0	2GB5V2500	250.0	8.4
2GB3VX600	60.0	.8	3GB3VX1060	106.0	2.1	3GB5VX900	90.0	4.5	2GB5V1400	140.0	4.4	3GB5V2500	250.0	12.6
3GB3VX600	60.0	1.2	4GB3VX1060	106.0	2.8	4GB5VX900	90.0	6.0	3GB5V1400	140.0	6.6	4GB5V2500	250.0	16.8
4GB3VX600	60.0	1.6	2GB3VX1120	112.0	1.4	2GB5VX950	95.0	3.0	4GB5V1400	140.0	8.8	2GB5V2650	265.0	8.6
2GB3VX630	63.0	.8	3GB3VX1120	112.0	2.1	3GB5VX950	95.0	4.5	2GB5V1500	150.0	4.6	3GB5V2650	265.0	12.9
3GB3VX630	63.0	1.2	4GB3VX1120	112.0	2.8	4GB5VX950	95.0	6.0	3GB5V1500	150.0	6.9	4GB5V2650	265.0	17.2
4GB3VX630	63.0	1.6	2GB3V1180▲	118.0	1.6	2GB5VX1000	100.0	3.2	4GB5V1500	150.0	9.2	2GB5V2800	280.0	9.0
2GB3VX670	67.0	.8	3GB3V1180▲	118.0	2.4	3GB5VX1000	100.0	4.8	5GB5V1500	150.0	11.5	3GB5V2800	280.0	13.5
3GB3VX670	67.0	1.2	4GB3V1180▲	118.0	3.2	4GB5VX1000	100.0	6.4	2GB5V1600	160.0	5.0	4GB5V2800	280.0	18.0
4GB3VX670	67.0	1.6	2GB3V1250▲	125.0	1.6	2GB5VX1000	106.0	3.4	3GB5V1600	160.0	7.5	2GB5V3000	300.0	10.0
2GB3VX710	71.0	1.0	3GB3V1250▲	125.0	2.4	3GB5VX1000	106.0	5.1	4GB5V1600	160.0	10.0	3GB5V3000	300.0	15.0
3GB3VX710	71.0	1.5	4GB3V1250▲	125.0	3.2	2GB5VX1060	106.0	3.4	2GB5V1700	170.0	5.6	4GB5V3000	300.0	20.0
4GB3VX710	71.0	2.0	2GB3V1320▲	132.0	1.8	3GB5VX1060	106.0	5.1	3GB5V1700	170.0	8.4			
2GB3VX750	75.0	1.0	3GB3V1320▲	132.0	2.7	4GB5VX1060	106.0	6.8	4GB5V1700	170.0	11.2			
3GB3VX750	75.0	1.5	4GB3V1320▲	132.0	3.6	5GB5VX1060	106.0	8.5	5GB5V1700	170.0	14.0			
4GB3VX750	75.0	2.0	2GB3V1400▲	140.0	1.8	2GB5VX1120	112.0	3.6	2GB5V1800	180.0	6.0			
2GB3VX800	80.0	1.0	3GB3V1400▲	140.0	2.7	3GB5VX1120	112.0	5.4	3GB5V1800	180.0	9.0			

Gripband belts with more ribs are available on special order or combinations of Stock Gripband belts may be ordered in matched sets for drives with more grooves; for example, two matched three rib Gripband belts may be used on a six groove drive.

Horsepower ratings for "X" Gripband belts are the same as appropriate number of Gripnotch® Belts; others same as Super Gripbelt® belts except "3V" Gripband belts marked (▲) are rated at 80% of "3VX" Gripnotch ratings.

Part No. 2GB3VX450 means - 2 = Two Ribs  
 GB = Gripband  
 3V = Cross Section  
 X = Notched Construction  
 450 = 45" Outside Length

For additional product information, visit [www.regalrexnord.com/Browning](http://www.regalrexnord.com/Browning)



# 3LP GRIPTWIST - BP GRIPTWIST BELT

## PREMIUM GRIPTWIST® BELT

**Adjustable to any length... Ideal for center drives, vibration suppression and hostile environments.**

**Available in infinite sizes...Convenient 5' sections, bulk 100' coils, or cut by the foot to customer specified length.**

### Higher Capacity

You don't need to compromise when you install Premium Griptwist belt, because this belt has remarkable strength and durability. In fact, Premium Griptwist belts deliver higher horsepower than any other link-type V-belt.

### Easy Installation

Premium Griptwist belts can be assembled to any length required in a matter of seconds, with just a twist of the wrist. No special tools required. No need to dismantle machinery.

### Perfect for Emergency Replacement

Premium Griptwist belt minimizes production downtime because it assembles and installs immediately for any length required. A supply of Premium Griptwist belts is positive insurance that you'll never be without the exact belt length you need.

### Vibration Free

Premium Griptwist belts have no equal in suppressing troublesome vibration. Because of their extremely close tolerances, they create and transmit up to 90% less vibration than classical endless V-belts.

### Low Stretch

Premium Griptwist belt's twist-lock design locks the belt links tightly to the length desired. Combined with the 100% urethane/polyester construction, this produces a belt with less than half the stretch of other link-type belts.

### Less Inventory

Premium Griptwist belts are available in standard 3L, A/4L and B/5L cross sections, replacing both standard and fractional horsepower V-belt inventory.

### Lower Drive Tensions

The Premium Griptwist belt's raw-edge cog construction allows lower drive tensions, extending both belt and bearing life.

### Cooler Running

The cross-link construction of Premium Griptwist belts dissipates heat rapidly, virtually eliminating heat buildup and fatigue.

### Superior Design and Materials

Premium Griptwist belt's durability and versatility lies in simplicity of design combined with high-strength urethane elastomer reinforced with multiple plies of polyester fabric. This results in an incredibly strong yet flexible belt, providing consistently high performance.

### Oil, Water, Chemical and Heat Resistant

Premium Griptwist belt's rugged construction withstands temperatures from 0° to 250° F provides excellent resistance to water, oils and many industrial chemicals.



**Table No.1**

Premium Griptwist Belt		
Product Name	100 Foot Part Number	5 Foot Part Number
3LP Griptwist	3LP GRIPTWIST 100FT	3LP GRIPTWIST 5FT
AP Griptwist	AP GRIPTWIST 100FT	AP GRIPTWIST 5FT
BP Griptwist	BP GRIPTWIST 100FT	BP GRIPTWIST 5FT

# V-DRIVES

## Among the World's Largest Selection of V-Belts, Sheaves and Bushings....

The breadth of the Browning® V-belt drive line means maximum economy, versatility and prompt availability for your every application....truly the right drive every time! When you specify Browning, you select from the broadest range of V-drive ratios and centers in the world-more than double the selection available from any other source.

- Over 2100 stock sizes in multiple groove sheaves, far more than any other manufacturer.
- Full range of sizes in *two* bushing types: the popular Browning Split Taper®. Choose the replaceable bushing that best suits the application-*no other manufacturer offers this choice.*
- Variable speed sheaves through 5 grooves, precision balanced to provide smooth vibration-free performance.
- "358" sheaves stocked in a range of fixed and variable pitch sizes
- Automated computer software program, Edge™ automated computer software program generates V-drive selections in seconds.

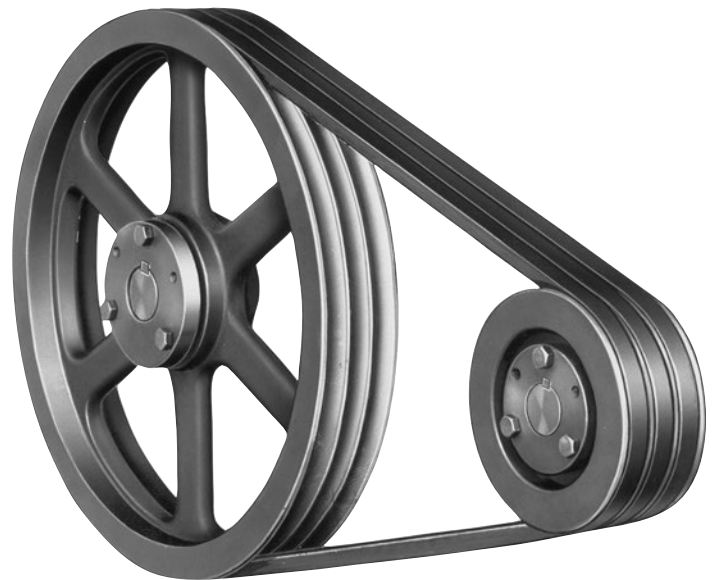

**VP variable speed sheave**



**MVP® variable speed sheave**



**Split-Taper Bushing**



**Multiple sheave**



**B5V® sheave**

## Classical Gripbelt® Sheaves - Bushing Type

Belt Size	Type		Number of Grooves						
			1	2	3	4	5	6	8
<b>A</b>	AKH	DD	2.8-18.0	2.8-18.0					
		Bore	1/2"-1 1/2"	1/2"-1 1/2"					
	AK	DD	1.8-18.0	1.8-18.0					
		Bore*	3/8-1 7/16	1/2-1 7/16					
<b>A-B</b>	BKH	DD	2.8-18.4	3.0-18.4					
		Bore	1/2-1 1/2	1/2-1 1/2					
	BK	DD	2.2-18.4	2.3-18.4					
		Bore*	3/8-1 7/16	1/2-1 7/16					
	B5V	A DD	3.8-27.3	3.8-27.3	3.8-27.3	3.8-27.3			
		B DD	4.2-27.8	4.2-27.8	4.2-27.8	4.2-27.8			
		Bore	1/2-2 7/16	1/2-2 7/16	1/2-2 7/16	1/2-2 7/16			
	TB	A DD	3.0-37.5	3.0-37.5	3.0-37.5	3.0-37.5	3.0-37.5	3.0-37.5	
		B DD	3.4-38.0	3.4-38.0	3.4-38.0	3.4-38.0	3.4-38.0	3.4-38.0	
		Bore	1/2-2 11/16	1/2-2 11/16	1/2-2 11/16	1/2-2 11/16	3/4"-2 5/8"	3/4"-2 5/8"	
B	A DD	5.0-37.5	5.0-37.5	5.0-37.5	5.0-37.5	6.6-37.5	6.6-37.5	5.0-37.5	
	B DD	5.4-38.0	5.4-38.0	5.4-38.0	5.4-38.0	7.0-38.5	7.0-38.5	5.4-38.0	
	Bore	3/4-3 3/4	3/4-3 3/4	3/4-3 3/4	3/4-3 3/4	1 1/8-3 3/4	1 1/8-3 3/4	1"-4 1/4"	
<b>C</b>	TC	DD	7.0-24.0	7.0-24.0	7.0-24.0	7.0-24.0	7.0-24.0	7.0-24.0	
		Bore	3/4-2 11/16	3/4-2 11/16	3/4-2 11/16	1-2 5/8	1-2 5/8		
	C	DD	5.6-6.0	5.6-44.0	5.6-50.0	5.6-50.0	9.0-50.0	9.0-50.0	7.0-50.0
		Bore	1/2-1 3/4	1/2-3 3/4	3/4-4 1/4	3/4-5	1 1/8-5	1 3/4-5	1 3/8-5

\*AK and BK are finished bore type

## "358" Gripbelt Sheaves

Belt Size	Type		Number of Grooves						
			1	2	3	4	5	6	8
<b>3V</b>	Bushing Type	PD	2.60-24.95	2.60-24.95	2.60-33.45	2.60-33.45	4.70-33.45	4.70-33.45	4.70-33.45
		Bore	3/8"-2 11/16"	3/8"-2 11/16"	3/8"-3 3/4"	3/8"-3 3/4"	1/2"-3 3/4"	3/4"-3 3/4"	1"-4 1/4"
	Finished Bore	PD	2.60-3.30	2.60-3.30	2.60-3.30	2.60-3.30			
		Bore	5/8-7/8	3/4-1 1/8	7/8-1 1/8	7/8-1 3/8			
<b>5V</b>	Bushing Type	PD	4.3-27.90	4.3-27.90	4.3-49.90	4.3-49.90	4.3-49.90	7.0-49.90	7.0-49.90
		Bore	1/2-2 7/8	1/2-3 3/4	1/2-5	1/2-5	3/4-5	1-5	1-5
<b>8V</b>	Bushing Type	PD				12.3-63.8	12.3-63.8	12.3-63.8	12.3-63.8
		Bore				1 11/16-5	1 11/16-5	1 11/16-5	1 7/8-7 7/16

Classical and "358" Gripbelt Sheaves are available in Browning Split Taper® bushing type.

### New Combination Groove

Same sheave accommodates A, B & 5V Belts!

### New Casting Design

Created through CAD and Finite Element Analysis

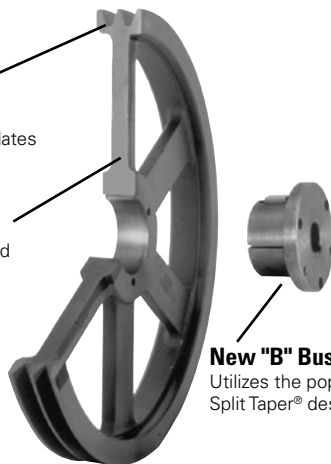

### New "B" Bushing

Utilizes the popular Browning Split Taper® design

## B5V® sheaves serve 90% of all 10-125 hp applications!

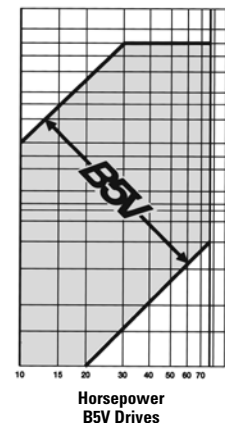
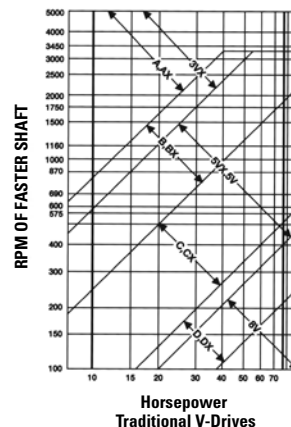

# STOCK SHEAVE LISTING

**Table No.1** 1 Groove "A" and "B" Sheaves

Datum Diameters		To 10 hp								Over 10 hp		
"A" Belts	"B" Belts	AS	AL & AM	AK Page 36	AKH Page 37	TA	BS	BK Page 40	BKH Page 41	B5V® Page 45	TB Page 48	Q-D® Page 72
1.25*	-	AS15	-	-	-	-	-	-	-	-	-	-
1.5	-	AS17	-	AK17*	-	-	-	-	-	-	-	-
1.8	2.0	AS20	-	AK20*	-	-	BS24	BK24*	-	-	-	-
1.9	2.3	AS21	-	AK21*	-	-	BS25	BK25*	-	-	-	-
2.0	2.4	AS22	-	AK22*	-	-	BS26	BK26*	-	-	-	-
2.1	2.5	AS23	-	AK23*	-	-	BS27	BK27*	-	-	-	-
2.2	2.6	-	-	-	-	-	BS28	BK28*	-	-	-	-
2.3	2.7	AS25	-	AK25*	-	-	-	-	-	-	-	-
2.4	2.8	AS26	-	AK26*	-	-	BS30	BK30*	BK30H	-	-	-
2.5	2.9	AS27	-	AK27*	-	-	-	-	-	-	-	-
2.6	3.0	AS28	-	AK28*	-	-	BS32	BK32*	BK32H	-	-	-
2.8	3.2	AS30	-	AK30*	AK30H	-	-	BK34	BK34H	-	-	-
3.0	3.4	AS32	-	AK32*	AK32H	1TA30(P1)	-	BK36	BK36H	-	1TB34(P1)	1B34SH
3.2	3.6	AS34	-	AK34*	AK34H	1TA32(P1)	-	BK40	BK40H	-	1TB36(P1)	1B36SH
3.4	3.8	-	-	-	-	1TA34(P1)	-	-	-	-	1TB38(P1)	1B38SH
3.5	3.9	-	-	AK39	AK39H	-	-	BK45	BK45H	-	-	-
3.6	4.0	-	-	-	-	1TA36(P1)	-	-	-	-	1TB40(P1)	1B40SH
3.7	4.1	-	-	AK41	AK41H	-	-	BK47	BK47H	-	-	-
3.8	4.2	-	-	-	-	1TA38(P1)	-	-	-	<b>1B5V42(P1)</b>	1TB42(P1)	1B42SH
4.0	4.4	-	-	AK44	AK44H	1TA40(P1)	-	BK50	BK50H	<b>1B5V44(P1)</b>	1TB44(P1)	1B44SH
4.2	4.6	-	-	AK46	AK46H	1TA42(P1)	-	BK52	BK52H	<b>1B5V46(B)</b>	1TB46(P1)	1B46SDS
4.4	4.8	-	-	-	-	1TA44(P1)	-	-	-	<b>1B5V48(B)</b>	1TB48(P1)	1B48SDS
4.5	4.9	-	-	AK49	AK49H	-	-	BK55	BK55H	-	-	-
4.6	5.0	-	-	-	-	1TA46(P1)	-	-	-	<b>1B5V50(B)</b>	1TB50(P1)	1B50SDS
4.7	5.1	-	-	AK51	AK51H	-	-	BK57	BK57H	-	-	-
4.8	5.2	-	-	-	-	1TA48(P1)	-	-	-	<b>1B5V52(B)</b>	1TB52(P1)	1B52SDS
5.0	5.4	-	AL54*	AK54	AK54H	1TA50(P1)	-	BK60	BK60H	<b>1B5V54(B)</b>	1TB54(P1)	1B54SDS
5.2	5.6	-	-	AK56	AK56H	1TA52(P1)	-	BK62	BK62H	<b>1B5V56(B)</b>	1TB56(P1)	1B56SDS
5.4	5.8	-	-	-	-	1TA54(P1)	-	-	-	<b>1B5V58(B)</b>	1TB58(P1)	1B58SDS
5.5	5.9	-	-	AK59	AK59H	-	-	BK65	BK65H	-	-	-
5.6	6.0	-	-	-	-	1TA56(P1)	-	-	-	<b>1B5V60(B)</b>	1TB60(P1)	1B60SDS
5.7	6.1	-	-	AK61	AK61H	-	-	BK67	BK67H	-	-	-
5.8	6.2	-	-	-	-	1TA58(P1)	-	-	-	<b>1B5V62(B)</b>	1TB62(P1)	1B62SDS
6.0	6.4	-	AL64*	AK64	AK64H	1TA60(P1)	-	BK70	BK70H	<b>1B5V64(B)</b>	1TB64(P1)	1B64SDS
6.2	6.6	-	-	AK66	AK66H	1TA62(P1)	-	BK72	BK72H	<b>1B5V66(B)</b>	1TB66(P1)	1B66SDS
6.4	6.8	-	-	-	-	1TA64(P1)	-	-	-	<b>1B5V68(B)</b>	1TB68(P1)	1B68SDS
6.5	6.9	-	-	AK69	AK69H	-	-	BK75	BK75H	-	-	-
6.6	7.0	-	-	-	-	-	-	-	-	<b>1B5V70(B)</b>	1TB70(P1)	1B70SDS
6.7	7.1	-	-	AK71	AK71H	-	-	BK77	BK77H	-	-	-
7.0	7.4	-	AL74*	AK74*	AK74H	1TA70(P1)	-	BK80	BK80H	<b>1B5V74(B)</b>	1TB74(P1)	1B74SDS
7.5	7.9	-	-	AK79*	AK79H	-	-	BK85	BK85H	-	-	-
7.6	8.0	-	-	-	-	-	-	-	-	<b>1B5V80(B)</b>	1TB80(P1)	1B80SDS
8.0	8.4	-	AL84*	AK84*	AK84H	-	-	BK90	BK90H	-	-	-
8.2	8.6	-	-	-	-	1TA82(P1)	-	-	-	<b>1B5V86(B)</b>	1TB86(P1)	1B86SDS
8.5	8.9	-	-	AK89*	AK89H	-	-	BK95	BK95H	-	-	-
8.6	9.0	-	-	-	-	-	-	-	-	<b>1B5V90(B)</b>	1TB90(P1)	1B90SDS
9.0	9.4	-	AL94*	AK94*	AK94H	1TA90(P1)	-	BK100	BK100H	<b>1B5V94(B)</b>	1TB94(P1)	1B94SDS
9.5	9.9	-	-	AK99*	AK99H	-	-	BK105	BK105H	-	-	-
10.0	10.4	-	AL104*	AK104*	AK104H	-	-	BK110	BK110H	-	-	-
10.5	10.9	-	-	AK109*	AK109H	-	-	BK115	BK115H	-	-	-
10.6	11.0	-	-	-	-	1TA106(P1)	-	-	-	<b>1B5V110(B)</b>	1TB110(P1)	1B110SDS
11.0	11.4	-	AL114*	AK114*	AK114H	-	-	BK120	BK120H	-	-	-
12.0	12.4	-	AL124*	AK124*	AK124H	1TA120(Q1)	-	BK130	BK130H	<b>1B5V124(B)</b>	1TB124(Q1)	1B124SDS
13.0	13.4	-	-	AK134	AK134H	-	-	BK140	BK140H	-	-	-
13.2	13.6	-	-	-	-	-	-	-	-	<b>1B5V136(B)</b>	1TB136(Q1)	1B136SDS
14.0	14.4	-	AM144*	AK144	AK144H	-	-	-	BK150H	-	-	-
15.0	15.4	-	-	AK154	AK154H	-	-	BK160	BK160H	<b>1B5V154(B)</b>	1TB154(Q1)	1B154SK
15.6	16.0	-	-	-	-	1TA150(Q1)	-	-	-	<b>1B5V160(B)</b>	1TB160(Q1)	1B160SK
18.0	18.4	-	-	AK184	AK184H	-	-	BK190	BK190H	<b>1B5V184(B)</b>	1TB184(Q1)	1B184SK
19.5	20.0	-	-	-	-	1TA180(Q1)	-	-	-	<b>1B5V200(B)</b>	1TB200(Q1)	1B200SK
22.9	23.4	-	-	-	-	1TA195(Q1)	-	-	-	<b>1B5V234(B)</b>	1TB250(Q1)	1B250SK
24.5	25.0	-	-	-	-	-	-	-	-	<b>1B5V250(B)</b>	1TB250(Q1)	1B250SK
27.3	27.8	-	-	-	-	1TA245(Q1)	-	-	-	<b>1B5V278(B)</b>	-	-
29.5	30.0	-	-	-	-	-	-	-	-	-	1TB300(Q1)	1B300SK
37.5	38.0	-	-	-	-	-	-	-	-	-	1TB380(Q1)	1B380SK

\* Do not use with Gripnatch® ("AX" or "BX") Belts.  
 "A" Belts will work in "B" Sheaves but "B" Belts will not work in "A" Sheaves.  
 Letter suffix on Part Number AKH, BKH and Q-D Sheaves indicate bushing size; bushing size is shown in parenthesis for B5V and TB Sheaves.

  Discontinued - Grey Columns in chart above are no longer available.

**Table No.2**  
**Browning® Split Taper® Bushing Bores**

Bushing	Bore Range (in.)
H	3/8-1 1/2
P1	1/2-1 3/4
B	1/2-2 7/16
Q1	3/4-2 11/16

**Table No.3**  
**Q-D® Bushing Bores**

Bushing	Bore Range (in.)
SH	1/2-1 5/8
SDS	1/2-2
SK	1/2-2 5/8



## STOCK SHEAVE LISTING

**Table No.1 2 Groove "A" and "B" Sheaves**

Datum Diameters		To 10 hp					Over 10 hp			
"A" Belts	"B" Belts	AK Page 38	AKH Page 39	TA	BK Page 42	BKH Page 43	B5V® Page 45	TB Page 49	B	Q-D® Page 72
1.8"	-	2AK20	-	-	-	-	-	-	-	-
1.9	2.3	2AK21	-	-	2BK25	-	-	-	-	-
2.0	-	2AK22	-	-	-	-	-	-	-	-
2.1	2.5	2AK23	-	-	2BK27	-	-	-	-	-
2.2	2.6	-	-	-	2BK28	-	-	-	-	-
2.3	-	2AK25	-	-	-	-	-	-	-	-
2.4	2.8	2AK26	-	-	2BK30	-	-	-	-	-
2.5	-	2AK27	-	-	-	-	-	-	-	-
2.6	3.0	2AK28	-	-	2BK32	2BK32H	-	-	-	-
2.8	3.2	2AK30	2AK30H	-	2BK34	2BK34H	-	-	-	-
3.0	3.4	2AK32	2AK32H	2TA30(P1)	2BK36	2BK36H	-	2TB34(P1)	-	2B34SH
3.2	3.6	2AK34	2AK34H	2TA32(P1)	2BK40	2BK40H	-	2TB36(P1)	-	2B36SH
3.4	3.8	-	-	2TA34(P1)	-	-	-	2TB38(P1)	-	2B38SH
3.5	3.9	2AK39	2AK39H	-	2BK45	2BK45H	-	-	-	-
3.6	4.0	-	-	2TA36(P1)	-	-	-	2TB40(P1)	-	2B40SH
3.7	4.1	2AK41	2AK41H	-	2BK47	2BK47H	-	-	-	-
3.8	4.2	-	-	2TA38(P1)	-	-	<b>2B5V42(P1)</b>	2TB42(P1)	-	2B42SH
4.0	4.4	2AK44	2AK44H	2TA40(P1)	2BK50	2BK50H	<b>2B5V44(P1)</b>	2TB44(P1)	-	2B44SH
4.2	4.6	2AK46	2AK46H	2TA42(P1)	2BK52	2BK52H	<b>2B5V46(B)</b>	2TB46(P1)	-	2B46SDS
4.4	4.8	-	-	2TA44(P1)	-	-	<b>2B5V48(B)</b>	2TB48(P1)	-	2B48SDS
4.5	4.9	2AK49	2AK49H	-	2BK55	2BK55H	-	-	-	-
4.6	5.0	-	-	2TA46(P1)	-	-	<b>2B5V50(B)</b>	2TB50(P1)	-	2B50SDS
4.7	5.1	2AK51	2AK51H	-	2BK57	2BK57H	-	-	-	-
4.8	5.2	-	-	2TA48(P1)	-	-	<b>2B5V52(B)</b>	2TB52(P1)	-	2B52SDS
5.0	5.4	2AK54	2AK54H	2TA50(P1)	2BK60	2BK60H	<b>2B5V54(B)</b>	2TB54(P1)	2B54Q(Q1)	2B54SDS
5.2	5.6	2AK56	2AK56H	2TA52(P1)	2BK62	2BK62H	<b>2B5V56(B)</b>	2TB56(P1)	2B56Q(Q1)	2B56SDS
5.4	5.8	-	-	2TA54(P1)	-	-	<b>2B5V58(B)</b>	2TB58(P1)	2B58Q(Q1)	2B58SDS
5.5	5.9	2AK59	2AK59H	-	2BK65	2BK65H	-	-	-	-
5.6	6.0	-	-	2TA56(P1)	-	-	<b>2B5V60(B)</b>	2TB60(P1)	2B60Q(Q1)	2B60SDS
5.7	6.1	2AK61	2AK61H	-	2BK67	2BK67H	-	-	-	-
5.8	6.2	-	-	2TA58(P1)	-	-	<b>2B5V62(B)</b>	2TB62(P1)	2B62Q(Q1)	2B62SDS
6.0	6.4	2AK64	2AK64H	2TA60(P1)	2BK70	2BK70H	<b>2B5V64(B)</b>	2TB64(P1)	2B64Q(Q1)	2B64SDS
6.2	6.6	-	-	2TA62(P1)	-	-	<b>2B5V66(B)</b>	2TB66(P1)	2B66Q(Q1)	2B66SDS
6.4	6.8	-	-	2TA64(P1)	-	-	<b>2B5V68(B)</b>	2TB68(P1)	2B68Q(Q1)	2B68SDS
6.6	7.0	-	-	-	-	-	<b>2B5V70(B)</b>	2TB70(Q1)	-	2B70SK
7.0	7.4	2AK74	2AK74H	2TA70(Q1)	2BK80	2BK80H	<b>2B5V74(B)</b>	2TB74(Q1)	-	2B74SK
7.6	8.0	-	-	-	-	-	<b>2B5V80(B)</b>	2TB80(Q1)	-	2B80SK
8.0	8.4	2AK84	2AK84H	-	2BK90	2BK90H	-	-	-	-
8.2	8.6	-	-	2TA82(Q1)	-	-	<b>2B5V86(B)</b>	2TB86(Q1)	-	2B86SK
8.6	9.0	-	-	-	-	-	<b>2B5V90(B)</b>	2TB90(Q1)	-	-
9.0	9.4	2AK94	2AK94H	2TA90(Q1)	2BK100	2BK100H	<b>2B5V94(B)</b>	2TB94(Q1)	-	2B94SK
10.0	10.4	2AK104	2AK104H	-	2BK110	2BK110H	-	-	-	-
10.6	11.0	-	-	2TA106(Q1)	-	-	<b>2B5V110(B)</b>	2TB110(Q1)	-	2B110SK
11.0	11.4	2AK114	2AK114H	-	2BK120	2BK120H	-	-	-	-
12.0	12.4	2AK124	2AK124H	2TA120(Q1)	2BK130	2BK130H	<b>2B5V124(B)</b>	2TB124(Q1)	-	2B124SK
13.0	13.4	2AK134	2AK134H	-	2BK140	2BK140H	-	-	-	-
13.2	13.6	-	-	-	-	-	<b>2B5V136(B)</b>	2TB136(Q1)	-	2B136SK
14.0	-	2AK144	2AK144H	-	-	-	-	-	-	-
15.0	15.4	2AK154	2AK154H	2TA150(Q1)	2BK160	2BK160H	<b>2B5V154(B)</b>	2TB154(Q1)	2B154R(R1)	2B154SK
15.6	16.0	-	-	-	-	-	<b>2B5V160(B)</b>	2TB160(Q1)	2B160R(R1)	2B160SK
18.0	18.4	2AK184	2AK184H	2TA180(Q1)	2BK190	2BK190H	<b>2B5V184(B)</b>	2TB184(Q1)	2B184R(R1)	2B184SK
19.5	20.0	-	-	2TA195(Q1)	-	-	<b>2B5V200(B)</b>	2TB200(Q1)	2B200R(R1)	2B200SF
22.9	23.4	-	-	-	-	-	<b>2B5V234(B)</b>	-	-	-
24.5	25.0	-	-	2TA245(Q1)	-	-	<b>2B5V250(B)</b>	2TB250(Q1)	2B250R(R1)	2B250SF
27.3	27.8	-	-	-	-	-	<b>2B5V278(B)</b>	-	-	-
29.5	30.0	-	-	-	-	-	-	2TB300(Q1)	2B300R(R1)	2B300SF
37.5	38.0	-	-	-	-	-	-	2TB380(Q1)	2B380R(R1)	2B380SF

Sheaves shown use "A" and "B" Belts.

"TB" and "B" Sheaves cannot be used with "5V" Belts.

Letter suffix on Part Number 2AKH, 2BKH and Q-D Sheaves indicate bushing size; bushing size is shown in parenthesis for B5V®, TB and B Sheaves.

Discontinued - Grey Columns in chart above are no longer available.

**Table No.2 Browning® Split Taper® Bushing Bores**

Bushing	Bore Range (in.)
H	3/8-1 1/2
P1	1/2-1 3/4
B	1/2-2 7/16
Q1	3/4-2 11/16
R1	1 1/8-3 3/4

**Table No.3 Q-D® Bushing Bores**

Bushing	Bore Range (in.)
SH	1/2-1 5/8
SDS	1/2-2
SK	1/2-2 5/8
SF	1/2-2 15/16

For additional product information, visit [www.regalrexnord.com/Browning](http://www.regalrexnord.com/Browning)

# STOCK SHEAVE LISTING

**Table No.1 3 Groove "A" and "B" Sheaves**

Datum Diameters		To 10 hp			Over 10 hp			
"A" Belts	"B" Belts	TA	3BK	3BKH	B5V® Page 46	TB Page 49	B	Q-D® Page 72
1.9"	2.3"	-	3BK25	-	-	-	-	-
2.1	2.5	-	3BK27	-	-	-	-	-
2.2	2.6	-	3BK28	-	-	-	-	-
2.4	2.6	-	3BK30	-	-	-	-	-
2.6	3.0	-	3BK32	-	-	-	-	-
2.8	3.2	-	3BK34	-	-	-	-	-
3.0	3.4	3TA30(P1)	3BK36	-	-	3TB34(P2)	-	3B34SH
3.2	3.6	3TA32(P1)	3BK40	-	-	3TB36(P2)	-	3B36SH
3.4	3.8	3TA34(P1)	-	-	-	3TB38(P1)	-	3B38SH
3.5	3.9	-	-	3BK45H	-	-	-	-
3.6	4.0	3TA36(P1)	-	-	-	3TB40(P1)	-	3B40SH
3.7	4.1	-	-	3BK47H	-	-	-	-
3.8	4.2	3TA38(P1)	-	-	<b>3B5V42(P1)</b>	3TB42(P1)	-	3B42SH
4.0	4.4	3TA40(P1)	-	3BK50H	<b>3B5V44(P1)</b>	3TB44(P1)	-	3B44SH
4.2	4.6	3TA42(P1)	-	3BK52H	<b>3B5V46(B)</b>	3TB46(P1)	-	3B46SD
4.4	4.8	3TA44(P1)	-	-	<b>3B5V48(B)</b>	3TB48(P1)	-	3B48SD
4.5	4.9	-	-	3BK55H	-	-	-	-
4.6	5.0	3TA46(P1)	-	-	<b>3B5V50(B)</b>	3TB50(P1)	-	3B50SD
4.7	5.1	-	-	3BK57H	-	-	-	-
4.8	5.2	3TA48(P1)	-	-	<b>3B5V52(B)</b>	3TB52(P1)	-	3B52SD
5.0	5.4	3TA50(P1)	-	3BK60H	<b>3B5V54(B)</b>	3TB54(P1)	3B54Q(Q1)	3B54SD
5.2	5.6	3TA52(P1)	-	3BK62H	<b>3B5V56(B)</b>	3TB56(P1)	3B56Q(Q1)	3B56SD
5.4	5.8	3TA54(P1)	-	-	<b>3B5V58(B)</b>	3TB58(P1)	3B58Q(Q1)	3B58SD
5.5	5.9	-	-	3BK65H	-	-	-	-
5.6	6.0	3TA56(P1)	-	-	<b>3B5V60(B)</b>	3TB60(P1)	3B60Q(Q1)	3B60SD
5.7	6.1	-	-	3BK67H	-	-	-	-
5.8	6.2	3TA58(P1)	-	-	<b>3B5V62(B)</b>	3TB62(P1)	3B62Q(Q1)	3B62SD
6.0	6.4	3TA60(P1)	-	3BK70H	<b>3B5V64(B)</b>	3TB64(P1)	3B64Q(Q1)	3B64SD
6.2	6.6	3TA62(P1)	-	-	<b>3B5V66(B)</b>	3TB66(P1)	3B66Q(Q1)	3B66SD
6.4	6.8	3TA64(P1)	-	-	<b>3B5V68(B)</b>	3TB68(P1)	3B68Q(Q1)	3B68SD
6.6	7.0	-	-	-	<b>3B5V70(B)</b>	3TB70(Q1)	-	3B70SK
7.0	7.4	3TA70(Q1)	-	3BK80H	<b>3B5V74(B)</b>	3TB74(Q1)	-	3B74SK
7.6	8.0	-	-	-	<b>3B5V80(B)</b>	3TB80(Q1)	-	3B80SK
8.0	8.4	-	-	3BK90H	-	-	-	-
8.2	8.6	3TA82(Q1)	-	-	<b>3B5V86(B)</b>	3TB86(Q1)	-	3B86SK
8.6	9.0	-	-	-	<b>3B5V90(B)</b>	3TB90(Q1)	-	-
9.0	9.4	3TA90(Q1)	-	3BK100H	<b>3B5V94(B)</b>	3TB94(Q1)	-	3B94SK
10.0	10.4	-	-	3BK110H	-	-	-	-
10.6	11.0	3TA106(Q1)	-	-	<b>3B5V110(B)</b>	3TB110(Q1)	-	3B110SK
11.0	11.4	-	-	3BK120H	-	-	-	-
12.0	12.4	3TA120(Q1)	-	3BK130H	<b>3B5V124(B)</b>	3TB124(Q1)	-	3B124SK
13.0	13.4	-	-	3BK140H	-	-	-	-
13.2	13.6	-	-	-	<b>3B5V136(B)</b>	3TB136(Q1)	-	3B136SK
15.0	15.4	3TA150(Q1)	-	3BK160H	<b>3B5V154(B)</b>	3TB154(Q1)	3B154R(R1)	3B154SK
15.6	16.0	-	-	-	<b>3B5V160(B)</b>	3TB160(Q1)	3B160R(R1)	3B160SK
18.0	18.4	3TA180(Q1)	-	3BK190H	<b>3B5V184(B)</b>	3TB184(Q1)	3B184R(R1)	3B184SK
19.5	20.0	3TA195(Q1)	-	-	<b>3B5V200(B)</b>	3TB200(Q1)	3B200R(R1)	3B200SF
22.9	23.4	-	-	-	<b>3B5V234(B)</b>	-	-	-
24.5	25.0	3TA245(Q1)	-	-	<b>3B5V250(B)</b>	3TB250(Q1)	3B250R(R1)	3B250SF
27.3	27.8	-	-	-	<b>3B5V278(B)</b>	-	-	-
29.5	30.0	-	-	-	-	3TB300(Q1)	3B300R(R1)	3B300SF
37.5	38.0	-	-	-	-	3TB380(Q1)	3B380R(R1)	3B380E

"TB" and "B" Sheaves cannot be used with "5V" Belts.  
Letter suffix on Part Number 3BKH and Q-D Sheaves indicate bushing size; bushing size is shown in parenthesis for B5V, TB and B Sheaves.

 Discontinued - Grey Columns in chart above are no longer available.

**Table No.2  
Browning® Split Taper® Bushing Bores**

Bushing	Bore Range (in.)
H	3/8-1 1/2
P1	1/2-1 3/4
P2	3/4-1 3/4
B	1/2-2 7/16
Q1	3/4-2 11/16
R1	1 1/8-3 3/4

**Table No.3  
Q-D® Bushing Bores**

Bushing	Bore Range (in.)
SH	1/2-1 5/8
SD	1/2-2
SK	1/2-2 5/8
SF	1/2-2 15/16
E	7/8-3 1/2



## STOCK SHEAVE LISTING

**Table No.1** **4 Groove "A" and "B" Sheaves**

Datum Diameters		To 10 hp	Over 10 hp			
"A" Belts	"B" Belts	TA	B5V® Page 45	TB Page 49	B	Q-D® Page 72
3.0	3.4	4TA30(P2)	-	4TB34(P2)	-	4B34SD
3.2	3.6	4TA32(P2)	-	4TB36(P2)	-	4B36SD
3.4	3.8	4TA34(P2)	-	4TB38(P1)	-	4B38SD
3.6	4.0	4TA36(P2)	-	4TB40(P1)	-	4B40SD
3.8	4.2	4TA38(P1)	<b>4B5V42(P1)</b>	4TB42(P1)	-	4B42SD
4.0	4.4	4TA40(P1)	<b>4B5V44(P1)</b>	4TB44(P1)	-	4B44SD
4.2	4.6	4TA42(P1)	<b>4B5V46(B)</b>	4TB46(P1)	-	4B46SD
4.4	4.8	4TA44(P1)	<b>4B5V48(B)</b>	4TB48(P1)	-	4B48SD
4.6	5.0	4TA46(P1)	<b>4B5V50(B)</b>	4TB50(P1)	-	4B50SD
4.8	5.2	4TA48(P1)	<b>4B5V52(B)</b>	4TB52(P1)	-	4B52SD
5.0	5.4	4TA50(P1)	<b>4B5V54(B)</b>	4TB54(P1)	4BQ54(Q1)	4B54SD
5.2	5.6	4TA52(P1)	<b>4B5V56(B)</b>	4TB56(P1)	4BQ56(Q1)	4B56SD
5.4	5.8	4TA54(P1)	<b>4B5V58(B)</b>	4TB58(P1)	4BQ58(Q1)	4B58SD
5.6	6.0	4TA56(P1)	<b>4B5V60(B)</b>	4TB60(P1)	4BQ60(Q1)	4B60SD
5.8	6.2	4TA58(P1)	<b>4B5V62(B)</b>	4TB62(P1)	4BQ62(Q1)	4B62SD
6.0	6.4	4TA60(P1)	<b>4B5V64(B)</b>	4TB64(P1)	4BQ64(Q1)	4B64SD
6.2	6.6	4TA62(P1)	<b>4B5V66(B)</b>	4TB66(P1)	4BQ66(Q1)	4B66SD
6.4	6.8	4TA64(P1)	<b>4B5V68(B)</b>	4TB68(P1)	4BQ68(Q1)	4B68SD
6.6	7.0	-	<b>4B5V70(B)</b>	4TB70(Q1)	-	4B70SK
7.0	7.4	4TA70(Q1)	<b>4B5V74(B)</b>	4TB74(Q1)	-	4B74SK
7.6	8.0	-	<b>4B5V80(B)</b>	4TB80(Q1)	-	4B80SK
8.2	8.6	4TA82(Q1)	<b>4B5V86(B)</b>	4TB86(Q1)	-	4B86SK
8.6	9.0	-	<b>4B5V90(B)</b>	4TB90(Q1)	-	-
9.0	9.4	4TA90(Q1)	<b>4B5V94(B)</b>	4TB94(Q1)	-	4B94SK
10.6	11.0	4TA106(Q1)	<b>4B5V110(B)</b>	4TB110(Q1)	-	4B110SK
12.0	12.4	4TA120(Q1)	<b>4B5V124(B)</b>	4TB124(Q1)	-	4B124SK
13.2	13.6	-	<b>4B5V136(B)</b>	4TB136(Q1)	-	4B136SK
15.0	15.4	4TA150(Q1)	<b>4B5V154(B)</b>	4TB154(Q1)	4B154R(R1)	4B154SF
15.6	16.0	-	<b>4B5V160(B)</b>	4TB160(Q1)	4B160R(R1)	4B160SF
18.0	18.4	4TA180(Q1)	<b>4B5V184(B)</b>	4TB184(Q1)	4B184R(R1)	4B184SF
19.5	20.0	4TA195(Q1)	<b>4B5V200(B)</b>	4TB200(Q1)	4B200R(R1)	4B200SF
22.9	23.4	-	<b>4B5V234(B)</b>	-	-	-
24.5	25.0	4TA245(Q1)	<b>4B5V250(B)</b>	4TB250(Q1)	4B250R(R1)	4B250E
27.3	27.8	-	<b>4B5V278(B)</b>	-	-	-
29.5	30.0	-	-	4TB300(Q1)	4B300R(R1)	4B300E
37.5	38.0	-	-	4TB380(Q1)	4B380R(R1)	4B380E

"TB" and "B" Sheaves cannot be used with "5V" Belts.  
Letter suffix on Part Number 3BKH and Q-D Sheaves indicate bushing size; bushing size is shown in parenthesis for B5V, TB and B Sheaves.

**Discontinued - Grey Columns in chart above are no longer available.**

**For additional product information, visit [www.regalrexnord.com/Browning](http://www.regalrexnord.com/Browning)**

# STOCK SHEAVE LISTING

**Table No.1** 5, 6 and 8 Groove "A-B" Sheaves

Datum		5 Grooves				6 Grooves				8 Grooves	
Diameters		TB	B	Q-D®	B5V®	TB	B	Q-D	B5V	B	Q-D
"A" Belts	"B" Belts	Page 51	Page 53	Page 74	Page 45	Page 49	Page 53	Page 75	Page 47	Page 54	Page 75
3.0"	3.4	5TB34(P2)	-	5B34SD	-	6TB34(P2)	-	6B34SD	-	-	-
3.2	3.6	5TB36(P2)	-	5B36SD	-	6TB36(P2)	-	6B36SD	-	-	-
3.4	3.8	5TB38(P2)	-	5B38SD	-	6TB38(P2)	-	6B38SD	-	-	-
3.6	4.0	5TB40(P2)	-	5B40SD	-	6TB40(P2)	-	6B40SD	-	-	-
3.8	4.2	5TB42(P2)	-	5B42SD	5B5V42(P1)	6TB42(P2)	-	6B42SD	6B5V42(P2)	-	-
4.0	4.4	5TB44(P2)	-	5B44SD	5B5V44(P2)	6TB44(P2)	-	6B44SD	6B5V44(P2)	-	-
4.2	4.6	5TB46(P2)	-	5B46SD	5B5V46(P2)	6TB46(P2)	-	6B46SD	6B5V46(P2)	-	-
4.4	4.8	5TB48(P2)	-	5B48SD	5B5V48(P2)	6TB48(P2)	-	6B48SD	6B5V48(P2)	-	-
4.6	5.0	5TB50(P2)	-	5B50SD	5B5V50(Q1)	6TB50(P2)	-	6B50SD	6B5V50(Q2)	-	-
4.8	5.2	5TB52(P2)	-	5B52SD	5B5V52(Q1)	6TB52(P2)	-	6B52SD	6B5V52(Q2)	-	-
5.0	5.4	5TB54(Q1)	-	5B54SK	5B5V54(Q1)	6TB54(Q1)	-	6B54SK	6B5V54(Q2)	8B54Q	8B54SK
5.2	5.6	5TB56(Q1)	-	5B56SK	5B5V55(Q1)	6TB56(Q1)	-	6B56SK	6B5V56(Q2)	8B56Q	8B56SK
5.4	5.8	5TB58(Q1)	-	5B58SK	5B5V58(Q1)	6TB58(Q1)	-	6B58SK	6B5V58(Q1)	8B58Q	-
5.6	6.0	5TB60(Q1)	-	5B60SK	5B5V60(Q1)	6TB60(Q1)	-	6B60SK	6B5V60(Q1)	8B60Q	8B60SF
5.8	6.2	5TB62(Q1)	-	5B62SK	5B5V62(Q1)	6TB62(Q1)	-	6B62SK	6B5V62(Q1)	8B62Q	-
6.0	6.4	5TB64(Q1)	-	5B64SK	5B5V64(Q1)	6TB64(Q1)	-	6B64SK	6B5V64(Q1)	8B64Q	8B64SF
6.2	6.6	5TB66(Q1)	-	5B66SK	5B5V66(Q1)	6TB66(Q1)	-	6B66SK	6B5V66(Q1)	8B66Q	-
6.4	6.8	5TB68(Q1)	-	5B68SK	5B5V68(Q1)	6TB68(Q1)	-	6B68SK	6B5V68(Q1)	8B68Q	8B68SF
6.6	7.0	5TB70(Q2)	5B70R(R1)	5B70SF	5B5V70(Q1)	6TB70(Q2)	6B70R(R1)	6B70SF	6B5V70(Q2)	8B70R	-
7.0	7.4	5TB74(Q2)	5B74R(R1)	5B74SF	5B5V74(Q1)	6TB74(Q2)	6B74R(R1)	6B74SF	6B5V74(Q2)	8B74R	8B74SF
7.6	8.0	5TB80(Q2)	5B80R(R1)	5B80SF	5B5V80(R1)	6TB80(Q2)	6B80R(R1)	6B80SF	6B5V80(R1)	8B80R	-
8.2	8.6	5TB86(Q2)	5B86R(R1)	5B86SF	5B5V86(R1)	6TB86(Q2)	6B86R(R1)	6B86SF	6B5V86(R1)	8B86R	8B86E
8.6	9.0	5TB90(Q2)	5B90R(R1)	-	5B5V90(R1)	6TB90(Q2)	6B90R(R1)	-	6B5V90(R1)	8B90R	-
9.0	9.4	5TB94(Q2)	5B94R(R1)	5B94SF	5B5V94(R1)	6TB94(Q2)	6B94R(R1)	6B94SF	6B5V94(R1)	8B94R	8B94E
10.6	11.0	5TB110(Q2)	5B110R(R1)	5B110SF	5B5V110(R1)	6TB110(Q2)	6B110R(R1)	6B110SF	6B5V110(R1)	8B110R	8B110E
12.0	12.4	5TB124(Q2)	5B124R(R1)	5B124SF	5B5V124(R1)	6TB124(Q2)	6B124R(R1)	6B124SF	6B5V124(R1)	8B124R	8B124E
13.2	13.6	5TB136(Q2)	5B136R(R1)	5B136SF	5B5V136(R1)	6TB136(Q2)	6B136R(R1)	6B136SF	-	8B136R	-
15.0	15.4	5TB154(Q2)	5B154R(R1)	5B154SF	5B5V154(R1)	6TB154(Q2)	6B154R(R1)	6B154SF	6B5V154(R1)	8B154R	8B154E
15.6	16.0	5TB160(Q2)	5B160R(R1)	5B160SF	5B5V160(R1)	6TB160(Q2)	6B160R(R1)	6B160SF	6B5V160(R1)	8B160R	-
18.0	18.4	5TB184(Q2)	5B184R(R1)	5B184SF	5B5V184(R1)	6TB184(Q2)	6B184R(R1)	6B184SF	6B5V184(R1)	8B184R	8B184F
19.5	20.0	5TB200(Q2)	5B200R(R1)	5B200E	5B5V200(R1)	6TB200(Q2)	6B200R(R1)	6B200E	6B5V200(R1)	8B200R	8B200F
24.5	25.0	5TB250(Q2)	5B250R(R1)	5B250E	5B5V250(R1)	6TB250(Q2)	6B250R(R1)	6B250E	6B5V250(R1)	8B250R	8B250F
29.5	30.0	5TB300(Q2)	5B300R(R1)	5B300E	-	6TB300(Q2)	6B300R(R1)	6B300E	-	8B300R	8B300F
29.5	30.0	-	-	-	-	-	-	-	-	8B300S	-
37.5	38.0	5TB380(Q2)	5B380R(R1)	5B380E	-	6TB380(Q2)	6B380R(R1)	6B380E	-	8B380R	8B380F
37.5	38.0	-	-	-	-	-	-	-	-	8B380S	-

**Table No.2** Browning® Split Taper® Bushing Bores

Bushing	Bore Range (in.)
P2	3/4 - 1 3/4
Q1	3/4 - 2 11/16
Q2	1 - 2 5/8
R1	1 1/8 - 3 3/4
R2	1 3/8 - 3 5/8
S1	1 11/16 - 4 1/4
U0	2 3/8 - 5 1/2

**Table No.3** Q-D® Bushing Bores

Bushing	Bore Range (in.)
SD	1/2 - 2
SK	1/2 - 2 5/8
SF	1/2 - 2 15/16
E	7/8 - 3 1/2
F	1 - 4
J	1 1/2 - 4 1/2



## STOCK SHEAVE LISTING

Table No.1

1-4 Groove "C" Sheaves

Datum	1 Groove			2 Grooves			3 Grooves			4 Grooves			
	Dia.	TC	C	Q-D®	TC	C	Q-D	TC	C	Q-D	TC	C	Q-D
"C" Belts	Page 55	Page 76	Page 76	Page 56	Page 76	Page 76	Page 56	Page 77	Page 77	Page 77	Page 57	Page 77	Page 77
5.0"	-	-	-	-	-	-	-	-	-	3C50SD	-	-	4C50SD
5.5	-	-	-	-	-	-	-	-	-	3C55SD	-	-	4C55SD
5.6	-	-	-	-	-	-	-	-	-	-	-	-	-
6.0	-	1C56P(P1)	-	-	2C56P(P1)	-	-	3C56P(P1)	-	-	-	4C56P(P2)	-
6.0	-	1C60Q(Q1)	-	-	2C60Q(Q1)	-	-	3C60Q(Q1)	-	-	-	4C60Q(Q2)	-
7.0	1TC70(Q1)	-	1C70SF	2TC70(Q1)	-	2C70SF	3TC70(Q1)	-	-	3C60SF	-	-	4C60SF
7.0	1TC70(Q1)	-	1C70SF	2TC70(Q1)	-	2C70SF	3TC70(Q1)	-	-	3C70SF	4TC70(Q2)	-	4C70SF
7.2	1TC72(Q1)	-	-	2TC72(Q1)	-	-	3TC72(Q1)	-	-	-	4TC72(Q2)	-	-
7.4	1TC74(Q1)	-	-	2TC74(Q1)	-	-	3TC74(Q1)	-	-	-	4TC74(Q2)	-	-
7.5	-	-	1C75SF	-	-	2C75SF	-	-	-	3C75SF	-	-	4C75SF
7.6	1TC76(Q1)	-	-	2TC76(Q1)	-	-	3TC76(Q1)	-	-	-	4TC76(Q2)	-	-
7.8	1TC78(Q1)	-	-	2TC78(Q1)	-	-	3TC78(Q1)	-	-	-	4TC78(Q2)	-	-
8.0	1TC80(Q1)	-	1C80SF	2TC80(Q1)	-	2C80SF	3TC80(Q1)	-	-	3C80E	-	-	4C80E
8.2	1TC82(Q1)	-	-	2TC82(Q1)	-	-	3TC82(Q1)	-	-	-	4TC82(Q2)	-	-
8.4	1TC84(Q1)	-	-	2TC84(Q1)	-	-	3TC84(Q1)	-	-	-	4TC84(Q2)	-	-
8.5	-	-	1C85SF	-	-	2C85SF	-	-	-	3C85E	-	-	4C85E
8.6	1TC86(Q1)	-	-	2TC86(Q1)	-	-	3TC86(Q1)	-	-	-	4TC86(Q2)	-	-
8.8	1TC88(Q1)	-	-	2TC88(Q1)	-	-	3TC88(Q1)	-	-	-	4TC88(Q2)	-	-
9.0	1TC90(Q1)	-	1C90SF	2TC90(Q1)	-	2C90SF	3TC90(Q1)	3C90R(R1)	3C90E	4TC90(Q2)	4C90R(R1)	4C90E	4C90E
9.2	1TC92(Q1)	-	-	2TC92(Q1)	-	-	3TC92(Q1)	3C92R(R1)	-	4TC92(Q2)	4C92R(R1)	-	-
9.4	1TC94(Q1)	-	-	2TC94(Q1)	-	-	3TC94(Q1)	3C94R(R1)	-	4TC94(Q2)	4C94R(R1)	-	-
9.5	-	-	1C95SF	-	-	2C95SF	-	-	-	3C95E	-	-	4C95E
9.6	1TC96(Q1)	-	-	2TC96(Q1)	-	-	3TC96(Q1)	3C96R(R1)	-	4TC96(Q2)	4C96R(R1)	-	-
9.8	1TC98(Q1)	-	-	2TC98(Q1)	-	-	3TC98(Q1)	3C98R(R1)	-	4TC98(Q2)	4C98R(R1)	-	-
10.0	1TC100(Q1)	-	1C100SF	2TC100(Q1)	-	2C100SF	3TC100(Q1)	3C100R(R1)	3C100E	4TC100(Q2)	4C100R(R1)	4C100E	4C100E
10.2	1TC102(Q1)	-	-	2TC102(Q1)	-	-	3TC102(Q1)	3C102R(R1)	-	4TC102(Q2)	4C102R(R1)	-	-
10.5	-	-	1C105SF	-	-	2C105SF	-	-	-	3C105E	-	-	4C105E
10.6	1TC106(Q1)	-	-	2TC106(Q1)	-	-	3TC106(Q1)	3C106R(R1)	-	4TC106(Q2)	4C106R(R1)	-	-
11.0	1TC110(Q1)	-	1C110SF	2TC110(Q1)	-	2C110SF	3TC110(Q1)	3C110R(R1)	3C110E	4TC110(Q2)	4C110R(R1)	4C110E	4C110E
11.4	1TC114(Q1)	-	-	2TC114(Q1)	-	-	3TC114(Q1)	-	-	4TC114(Q2)	-	-	-
12.0	1TC120(Q1)	-	1C120SF	2TC120(Q1)	-	2C120SF	3TC120(Q1)	3C120R(R1)	3C120E	4TC120(Q2)	4C120R(R1)	4C120E	4C120E
13.0	1TC130(Q1)	-	1C130SF	2TC130(Q1)	-	2C130SF	3TC130(Q1)	3C130R(R1)	3C130E	4TC130(Q2)	4C130R(R1)	4C130E	4C130E
14.0	-	-	1C140SF	-	2C140R(R1)	2C140SF	-	3C140R(R1)	3C140E	-	4C140R(R1)	4C140E	4C140E
15.0	-	-	-	-	-	-	-	3C150R(R1)	-	-	4C150R(R1)	-	-
16.0	1TC160(Q1)	-	1C160SF	2TC160(Q1)	-	2C160SF	3TC160(Q1)	3C160R(R1)	3C160E	4TC160(Q2)	4C160R(R1)	4C160E	4C160E
18.0	-	-	1C180SF	-	2C180R(R1)	2C180SF	-	3C180R(R1)	3C180E	-	4C180R(R1)	4C180E	4C180E
18.0	-	-	-	-	-	-	-	-	-	-	4C180S(S1)	-	-
20.0	1TC200(Q1)	-	1C200SF	2TC200(Q1)	-	2C200SF	3TC200(Q1)	3C200R(R1)	3C200E	4TC200(Q2)	4C200R(R1)	4C200E	4C200E
20.0	-	-	-	-	-	-	-	-	-	-	4C200S(S1)	-	-
24.0	1TC240(Q1)	-	1C240SF	2TC240(Q1)	-	2C240SF	3TC240(Q1)	3C240R(R1)	3C240E	4TC240(Q2)	4C240R(R1)	4C240F	4C240F
24.0	-	-	-	-	-	-	-	-	-	-	4C240S(S1)	-	-
27.0	-	-	-	-	2C270R(R1)	-	-	3C270R(R1)	3C270E	-	4C270R(R1)	4C270F	4C270F
27.0	-	-	-	-	-	-	-	-	-	-	4C270S(S1)	-	-
30.0	-	-	-	-	-	2C300R(R1)	2C300F	-	-	-	4C300R(R1)	4C300F	4C300F
30.0	-	-	-	-	-	-	-	-	-	-	4C300S(S1)	-	-
36.0	-	-	-	-	-	2C360R(R1)	-	-	-	3C360F	4C360R(R1)	4C360F	4C360F
36.0	-	-	-	-	-	-	-	-	-	-	4C360S(S1)	-	-
44.0	-	-	-	-	2C440R(R1)	-	-	3C440R(R1)	3C440F	-	4C440R(R1)	4C440J	4C440J
44.0	-	-	-	-	-	-	-	-	-	-	4C440U(U0)	-	-
50.0	-	-	-	-	-	-	-	3C500R(R1)	3C500F	-	4C500R(R1)	4C500J	4C500J
50.0	-	-	-	-	-	-	-	3C500S(S1)	-	-	4C500U(U0)	-	-

Bushing size is shown in parentheses for TC and C Sheaves; letter suffix on part number for Q-D Sheaves indicates bushing size.

Table No.2  
Browning® Split Taper® Bushing Bores

Bushing	Bore Range (in.)
P1	1/2 - 1 3/4
P2	3/4 - 1 3/4
Q1	3/4 - 2 11/16
Q2	1 - 2 5/8
R1	1 1/8 - 3 3/4
R2	1 3/8 - 3 5/8
S1	1 11/16 - 4 1/4
U0	2 3/8 - 5 1/2

Table No.3  
Q-D® Bushing Bores

Bushing	Bore Range (in.)
SD	1/2 - 2
SF	1/2 - 2 15/16
E	7/8 - 3 1/2
F	1 - 4
J	1 1/2 - 4 1/2

For additional product information, visit [www.regalrexnord.com/Browning](http://www.regalrexnord.com/Browning)

# STOCK SHEAVE LISTING

**Table No.1**

**5, 6, 7 and 8 Groove "C" Sheaves**

Datum Dia.	5 Grooves			6 Grooves			7 Grooves	8 Grooves	
	TC	C	Q-D*	TC	C	Q-D	C	C	Q-D
"C" Belts	Page 58	Page 60	Page 77	Page 58	Page 60	Page 78	Page 60	Page 61	Page 78
6.0"	-	-	5C60SF	-	-	6C60SF	-	-	-
7.0	5TC70(Q2)	-	5C70SF	6TC70(Q2)	-	6C70SF	7C70Q(Q3)	8C70Q(Q3)	-
7.2	5TC72(Q2)	-	-	6TC72(Q2)	-	-	-	-	-
7.4	5TC74(Q2)	-	-	6TC74(Q2)	-	-	-	-	-
7.5	-	-	5C75SF	-	-	6C75SF	-	-	-
7.6	5TC76(Q2)	-	-	6TC76(Q2)	-	-	-	-	-
7.8	5TC78(Q2)	-	-	6TC78(Q2)	-	-	-	-	-
8.0	5TC80(Q2)	-	5C80E	6TC80(Q2)	-	6C80E	7C80R(R2)	8C80R(R2)	8C80E
8.2	5TC82(Q2)	-	-	6TC82(Q2)	-	-	-	-	-
8.4	5TC84(Q2)	-	-	6TC84(Q2)	-	-	-	-	-
8.5	-	-	5C85E	-	-	6C85E	-	-	8C85E
8.6	5TC86(Q2)	-	-	6TC86(Q2)	-	-	7C86R(R2)	8C86R(R2)	-
8.8	5TC88(Q2)	-	-	6TC88(Q2)	-	-	-	-	-
9.0	5TC90(Q2)	5C90R(R1)	5C90E	6TC90(Q2)	6C90R(R2)	6C90F	7C90R(R2)	8C90R(R2)	8C90F
9.2	5TC92(Q2)	5C92R(R1)	-	6TC92(Q2)	6C92R(R2)	-	7C92R(R2)	8C92R(R2)	-
9.4	5TC94(Q2)	5C94R(R1)	-	6TC94(Q2)	6C94R(R2)	-	7C94R(R2)	8C94R(R2)	-
9.5	-	-	5C95E	-	-	6C95F	-	-	8C95F
9.6	5TC96(Q2)	5C96R(R1)	-	6TC98(Q2)	6C96R(R2)	-	-	8C96R(R2)	-
9.8	5TC98(Q2)	5C98R(R1)	-	6TC98(Q2)	6C98R(R2)	-	7C98R(R2)	8C98R(R2)	-
10.0	5TC100(Q2)	5C100R(R1)	5C100E	6TC100(Q2)	6C100R(R2)	6C100F	7C100R(R2)	8C100R(R2)	8C100F
10.2	5TC102(Q2)	5C102R(R1)	-	6TC102(Q2)	6C102R(R2)	-	7C102R(R2)	8C102R(R2)	-
10.5	-	-	5C105E	-	-	6C105F	-	-	8C105F
10.6	5TC106(Q2)	5C106R(R1)	-	6TC106(Q2)	6C106R(R2)	-	7C106R(R2)	8C106R(R2)	-
11.0	5TC110(Q2)	5C110R(R1)	5C110E	6TC110(Q2)	6C110R(R2)	6C110F	7C110R(R2)	8C110R(R2)	8C110F
11.4	5TC114(Q2)	-	-	6TC114(Q2)	-	-	-	-	-
12.0	5TC120(Q2)	5C120R(R1)	5C120E	6TC120(Q2)	6C120R(R2)	6C120F	7C120R(R2)	8C120R(R2)	8C120F
13.0	5TC130(Q2)	5C130R(R1)	5C130E	6TC130(Q2)	6C130R(R2)	6C130F	7C130R(R2)	8C130R(R2)	8C130F
14.0	-	5C140R(R1)	5C140E	-	6C140R(R2)	6C140F	7C140R(R2)	8C140R(R2)	8C140F
15.0	-	5C150R(R1)	-	-	6C150R(R2)	-	7C150R(R2)	8C150R(R2)	-
16.0	5TC160(Q2)	5C160R(R1)	5C160E	6TC160(Q2)	6C160R(R2)	6C160F	7C160R(R2)	8C160R(R2)	8C160F
18.0	-	5C180R(R1)	5C180E	-	6C180R(R2)	6C180F	7C180S(S2)	8C180S(S2)	8C180F
18.0	-	5C180S(S1)	-	-	6C180S(S1)	-	7C180U(U0)	8C180U(U0)	-
20.0	5TC200(Q2)	5C200R(R1)	5C200F	6TC200(Q2)	6C200R(R2)	6C200F	7C200S(S2)	8C200S(S2)	8C200J
20.0	-	5C200S(S1)	-	-	6C200S(S1)	-	7C200U(U0)	8C200U(U0)	-
24.0	5TC240(Q2)	5C240R(R1)	5C240F	6TC240(Q2)	6C240R(R2)	6C240F	7C240S(S2)	8C240S(S2)	8C240J
24.0	-	5C240S(S1)	-	-	6C240S(S1)	-	-	8C240U(U0)	-
27.0	-	5C270R(R2)	5C270F	-	6C270R(R2)	6C270J	7C270S(S2)	8C270S(S2)	8C270J
27.0	-	-	-	-	6C270S(S1)	-	7C270U(U0)	-	-
30.0	-	5C300R(R2)	5C300F	-	6C300R(R2)	6C300J	7C300S(S2)	8C300S(S2)	8C300J
30.0	-	5C300S(S1)	-	-	6C300U(U0)	-	7C300U(U0)	8C300U(U0)	-
36.0	-	5C360R(R2)	5C360J	-	6C360R(R2)	6C360J	7C360S(S2)	8C360S(S2)	8C360M
36.0	-	-	-	-	6C360U(U0)	-	-	8C360U(U0)	-
44.0	-	5C440R(R2)	5C440J	-	6C440R(R2)	6C440J	7C440S(S2)	8C440S(S2)	8C440M
44.0	-	-	-	-	-	-	-	8C440U(U0)	-
50.0	-	5C500R(R2)	5C500J	-	6C500R(R2)	6C500M	7C500S(S2)	8C500S(S2)	8C500M

Bushing size is shown in parentheses for TC and C Sheaves; letter suffix on part number for Q-D Sheaves indicates bushing size.

**Table No.2**  
**Browning® Split Taper® Bushing Bores**

Bushing	Bore Range (in.)
Q2	1 - 2 5/8
Q3	1 3/8 - 2 1/2
R1	1 1/8 - 3 3/4
R2	1 3/8 - 3 5/8
S1	1 11/16 - 4 1/4
S2	1 7/8 - 4 3/16
U0	2 3/8 - 5 1/2
U1	2 3/8 - 5 1/2

**Table No.3**  
**Q-D® Bushing Bores**

Bushing	Bore Range (in.)
SF	1/2 - 2 15/16
E	7/8 - 3 1/2
F	1 - 4
J	1 1/2 - 4 1/2
M	2 - 5 1/2



## STOCK SHEAVE LISTING

**Table No.1** 1 to 8 Groove "3V" Sheaves

Nom. Pitch Dia.	1 Groove			2 Grooves			3 Grooves			4 Grooves		
	Split Taper Bushing	Finished Bore	Q-D® Bushing	Split Taper Bushing	Finished Bore	Q-D Bushing	Split Taper Bushing	Finished Bore	Q-D Bushing	Split Taper Bushing	Finished Bore	Q-D Bushing
	Page 63	Page 63	Page 79	Page 63	Page 63	Page 79	Page 63	Page 63	Page 80	Page 63	Page 63	Page 80
2.2"	-	-	13V220JA	-	-	23V220JA	-	-	-	-	-	-
2.3	-	-	13V235JA	-	-	23V235JA	-	-	-	-	-	-
2.5	-	-	13V250JA	-	-	23V250JA	-	-	33V250JA	-	-	-
2.6	1G3V26(G)	1F3V26	13V265JA	2G3V26(G)	2F3V26	23V265JA	3G3V26(G)	3F3V26	33V265JA	4G3V26(G)	4F3V26	43V265JA
2.8	1G3V28(G)	1F3V28	13V280JA	2G3V28(G)	2F3V28	23V280JA	3G3V28(G)	3F3V28	33V280JA	4G3V28(G)	4F3V28	43V280JA
3.0	1G3V30(G)	1F3V30	13V300JA	2G3V30(G)	2F3V30	23V300JA	3G3V30(G)	3F3V30	33V300SH	4G3V30(G)	4F3V30	43V300SH
3.1	1H3V31(H)	1F3V31	13V315JA	2H3V31(H)	2F3V31	23V315JA	3H3V31(H)	3F3V31	33V315SH	4H3V31(H)	4F3V31	43V315SH
3.3	1H3V33(H)	1F3V33	13V335JA	2H3V33(H)	2F3V33	23V335SH	3H3V33(H)	3F3V33	33V335SH	4H3V33(H)	4F3V33	43V335SH
3.6	1H3V36(H)	-	13V365SH	2H3V36(H)	-	23V365SH	3P3V36(P1)	-	33V365SH	4P3V36(P1)	-	43V365SH
3.6	1P3V36(P1)	-	-	2P3V36(P1)	-	-	-	-	-	-	-	-
4.1	1H3V41(H)	-	13V412SH	2H3V41(H)	-	23V412SH	3P3V41(P1)	-	33V412SH	4P3V41(P1)	-	43V412SH
4.1	1H3V45(H)	-	-	2P3V41(P1)	-	-	-	-	-	-	-	-
4.5	1P3V45(P1)	-	13V450SH	2H3V45(H)	-	23V450SH	3P3V45(P1)	-	33V450SDS	4P3V45(P1)	-	43V450SDS
4.5	1H3V47(H)	-	-	2P3V45(P1)	-	-	-	-	-	-	-	-
4.7	1P3V47(P1)	-	13V475SH	2H3V47(H)	-	23V475SH	3P3V47(P1)	-	33V475SDS	4P3V47(P1)	-	43V475SDS
4.7	1H3V47(H)	-	-	2P3V47(P1)	-	-	-	-	-	-	-	-
5.0	1H3V50(H)	-	13V500SH	2H3V50(H)	-	23V500SH	3P3V50(P1)	-	33V500SDS	4P3V50(P1)	-	43V500SDS
5.0	1P3V50(P1)	-	-	2P3V50(P1)	-	-	-	-	-	-	-	-
5.3	1H3V53(H)	-	13V530SH	2H3V53(H)	-	23V530SH	3P3V53(P1)	-	33V530SDS	4P3V53(P1)	-	43V530SDS
5.3	1P3V53(P1)	-	-	2P3V53(P1)	-	-	-	-	-	-	-	-
5.6	1H3V56(H)	-	13V560SH	2H3V56(H)	-	23V560SH	3P3V56(P1)	-	33V560SDS	4P3V56(P1)	-	43V560SDS
5.6	1P3V56(P1)	-	-	2P3V56(P1)	-	-	-	-	-	-	-	-
6.0	1H3V60(H)	-	13V600SH	2H3V60(H)	-	23V600SH	3P3V60(P1)	-	33V600SDS	4Q3V60(Q1)	-	43V600SK
6.0	1P3V60(P1)	-	-	2P3V60(P1)	-	-	-	-	-	-	-	-
6.5	1P3V65(P1)	-	13V650SH	2Q3V65(Q1)	-	23V650SDS	3Q3V65(Q1)	-	33V650SDS	4Q3V65(Q1)	-	43V650SK
6.9	1P3V69(P1)	-	13V690SH	2Q3V69(Q1)	-	23V690SDS	3Q3V69(Q1)	-	33V690SDS	4Q3V69(Q1)	-	43V690SK
8.0	1P3V80(P1)	-	13V800SDS	2Q3V80(Q1)	-	23V800SDS	3Q3V80(Q1)	-	33V800SK	4Q3V80(Q1)	-	43V800SK
10.6	1P3V106(P1)	-	13V1060SDS	2Q3V106(Q1)	-	23V1060SK	3Q3V106(Q1)	-	33V1060SK	4Q3V106(Q1)	-	43V1060SK
14.0	1Q3V140(Q1)	-	13V1400SK	2Q3V140(Q1)	-	23V1400SK	3Q3V140(Q1)	-	33V1400SK	4Q3V140(Q1)	-	43V1400SK
19.0	1Q3V190(Q1)	-	13V1900SK	2Q3V190(Q1)	-	23V1900SK	3R3V190(R1)	-	33V1900SF	4R3V190(R1)	-	43V1900SF
25.0	1Q3V250(Q1)	-	-	2Q3V250(Q1)	-	23V2500SK	3R3V250(R1)	-	33V2500SF	4R3V250(R1)	-	43V2500SF
33.5	-	-	-	-	-	-	3R3V335(R1)	-	33V3350SF	4R3V335(R1)	-	43V3350E

Nom. Pitch Dia.	5 Grooves		6 Grooves		8 Grooves	
	Split Taper Bushing	Q-D Bushing	Split Taper Bushing	Q-D Bushing	Split Taper Bushing	Q-D Bushing
	Page 63	Page 78	Page 63	Page 78	Page 63	Page 78
4.7"	5P3V47(P1)	53V475SDS	6Q3V47(Q1)	63V475SK	8Q3V47(Q2)	83V475SK
5.0	5P3V50(P1)	53V500SDS	6Q3V50(Q1)	63V500SK	8Q3V50(Q2)	83V500SK
5.3	5P3V53(P1)	53V530SK	6Q3V53(Q1)	63V530SK	8Q3V53(Q2)	83V530SK
5.6	5P3V56(P1)	53V560SK	6Q3V56(Q1)	63V560SK	8Q3V56(Q2)	83V560SK
6.0	5Q3V60(Q1)	53V600SK	6Q3V60(Q1)	63V600SK	8Q3V60(Q2)	83V600SK
6.5	5Q3V65(Q1)	53V650SK	6Q3V65(Q1)	63V650SK	8Q3V65(Q2)	83V650SK
6.9	5Q3V69(Q1)	53V690SK	6Q3V69(Q1)	63V690SK	8Q3V69(Q2)	83V690SK
8.0	5Q3V80(Q1)	53V800SK	6Q3V80(Q1)	63V800SK	8Q3V80(R1)	83V800SF
10.6	5Q3V106(Q1)	53V1060SK	6R3V106(R1)	63V1060SF	8R3V106(R1)	83V1060SF
14.0	5Q3V140(Q1)	53V1400SF	6R3V140(R1)	63V1400SF	8R3V140(R1)	83V1400E
19.0	5R3V190(R1)	53V1900SF	6R3V190(R1)	63V1900E	8R3V190(R1)	83V1900E
25.0	5R3V250(R1)	53V2500E	6R3V250(R1)	63V2500E	8R3V250(R1)	83V2500E
33.5	5R3V335(R1)	53V3350E	6R3V335(R1)	63V3350E	8R3V335(S1)	83V3350F

Bushing size is shown in parentheses for Split Taper Bushing Sheaves; letter suffix on part number for Q-D Sheaves indicates bushing size.

**Table No.2** Browning® Split Taper® Bushing Bores

Bushing	Bore Range (in.)	Bushing	Bore Range (in.)
G	3/8 - 1	S1	1 11/16 - 4 1/4
H	3/8 - 1 1/2	S1	1 7/8 - 4 3/16
P1	1/2 - 1 3/4	U0	2 3/8 - 5 1/2
Q1	3/4 - 2 11/16	U1	2 3/8 - 5 1/2
Q2	1 - 2 5/8	U2	2 7/16 - 5
R1	1 1/8 - 3 3/4	W1	3 3/8 - 7 7/16
R2	1 3/8 - 3 5/8	W2	3 3/8 - 7 7/16

**Table No.3** Q-D® Bushing Bores

Bushing	Bore Range (in.)	Bushing	Bore Range (in.)
JA	1/2 - 1 1/4	E	7/8 - 3 1/2
SH	1/2 - 1 5/8	F	1 - 4
SDS	1/2 - 2	J	1 1/2 - 4 1/2
SD	1/2 - 2	M	2 - 5 1/2
SK	1/2 - 2 5/8	N	2 7/16 - 5 7/8
SF	1/2 - 2 15/16	P	2 15/16 - 7

For additional product information, visit [www.regalrexnord.com/Browning](http://www.regalrexnord.com/Browning)

# STOCK SHEAVE LISTING

Table No.1

1 to 4 Groove "5V" Sheaves

Pitch Diameter	2 Grooves				3 Grooves			4 Grooves		
	B5V® Page 45	B5V Page 45	5V Page 67	Q-D® Page 82	B5V Page 46	5V Page 67	Q-D Page 82	B5V Page 46	5V Page 68	Q-D Page 82
4.3"	1B5V42(P1)	2B5V42(P1)	2P5V44(P1)	25V440SH	3B5V42(P1)	3P5V44(P1)	35V440SDS	4B5V42(P1)	4P5V44(P1)	45V440SD
4.5	1B5V44(P1)	2B5V44(P1)	2Q5V46(Q1)	25V465SDS	-	3Q5V46(Q1)	35V465SDS	-	4Q5V46(Q1)	45V465SD
4.7	1B5V46(P1)	2B5V46(P1)	-	-	3B5V46(B)	-	-	4B5V46(B)	-	-
4.8	-	-	2Q5V49(Q1)	25V490SDS	-	3Q5V49(Q1)	35V490SDS	-	4Q5V49(Q1)	45V490SD
4.9	1B5V48(B)	2B5V48(B)	-	-	3B5V48(B)	-	-	4B5V48(B)	-	-
5.1	1B5V50(B)	2B5V50(B)	2Q5V52(Q1)	25V520SDS	3B5V50(B)	3Q5V52(Q1)	35V520SDS	4B5V50(B)	4Q5V52(Q1)	45V520SD
5.3	1B5V52(B)	2B5V52(B)	-	-	3B5V52(B)	-	-	4B5V52(B)	-	-
5.4	-	-	2Q5V55(Q1)	25V550SDS	-	3Q5V55(Q1)	35V550SDS	-	4Q5V55(Q1)	45V550SD
5.5	1B5V54(B)	2B5V54(B)	-	-	3B5V54(B)	-	-	4B5V54(B)	-	-
5.7	1B5V56(B)	2B5V56(B)	-	-	3B5V56(B)	-	-	4B5V56(B)	-	-
5.8	-	-	2Q5V59(Q1)	25V59SDS	-	3Q5V59(Q1)	35V59SDS	-	4Q5V59(Q1)	45V59SD
5.9	1B5V58(B)	2B5V58(B)	-	-	3B5V58(B)	-	-	4B5V58(B)	-	-
6.1	1B5V60(B)	2B5V60(B)	-	-	3B5V60(B)	-	-	4B5V60(B)	-	-
6.2	-	-	2Q5V63(Q1)	25V630SK	-	3Q5V63(Q1)	35V630SK	-	4Q5V63(Q1)	45V630SK
6.3	1B5V62(B)	2B5V62(B)	-	-	3B5V62(B)	-	-	4B5V62(B)	-	-
6.5	1B5V64(B)	2B5V64(B)	-	-	3B5V64(B)	-	-	4B5V64(B)	-	-
6.6	-	-	2Q5V67(Q1)	25V670SK	-	3Q5V67(Q1)	35V670SK	-	4Q5V67(Q1)	45V670SK
6.7	1B5V66(B)	2B5V66(B)	-	-	3B5V66(B)	-	-	4B5V66(B)	-	-
6.9	1B5V68(B)	2B5V68(B)	-	-	3B5V68(B)	-	-	4B5V68(B)	-	-
7.0	-	-	2Q5V71(Q1)	25V710SK	-	3Q5V71(Q1)	35V710SF	-	4Q5V71(Q1)	45V710SF
7.1	1B5V70(B)	2B5V70(B)	-	-	3B5V70(B)	-	-	4B5V70(B)	-	-
7.4	-	-	2Q5V75(Q1)	25V750SK	-	3Q5V75(Q1)	35V750SF	-	4Q5V75(Q1)	45V750SF
7.5	1B5V74(B)	2B5V74(B)	-	-	3B5V74(B)	-	-	4B5V74(B)	-	-
7.9	-	-	2Q5V80(Q1)	25V800SK	-	3R5V80(R1)	35V800SF	-	4R5V80(R1)	45V800E
8.1	1B5V80(B)	2B5V80(B)	-	-	3B5V80(B)	-	-	4B5V80(B)	-	-
8.4	-	-	2Q5V85(Q1)	25V850SK	-	3R5V85(R1)	35V850SF	-	4R5V85(R1)	45V850E
8.7	1B5V86(B)	2B5V86(B)	-	-	3B5V86(B)	-	-	4B5V86(B)	-	-
8.9	-	-	2Q5V90(Q1)	25V900SK	-	3R5V90(R1)	35V900SF	-	4R5V90(R1)	45V900E
9.1	1B5V90(B)	2B5V90(B)	2Q5V92(Q1)	25V925SK	3B5V90(B)	3R5V92(R1)	35V925SF	4B5V90(B)	4R5V92(R1)	45V925E
9.5	1B5V94(B)	2B5V94(B)	-	-	3B5V94(B)	-	-	4B5V94(B)	-	-
9.7	-	-	2Q5V97(Q1)	25V975SK	-	3R5V97(R1)	35V975SF	-	4R5V97(R1)	45V975E
10.2	-	-	2Q5V103(Q1)	25V1030SK	-	3R5V103(R1)	35V1030SF	-	4R5V103(R1)	45V1030E
10.8	-	-	2Q5V109(Q1)	25V1090SK	-	3R5V109(R1)	35V1090SF	-	4R5V109(R1)	45V1090E
11.1	1B5V110(B)	2B5V110(B)	-	-	3B5V110(B)	-	-	4B5V110(B)	-	-
11.2	-	-	-	25V1130SK	-	-	35V1130SF	-	-	45V1130E
11.7	-	-	2Q5V118(Q1)	25V1180SK	-	3R5V118(R1)	35V1180SF	-	4R5V118(R1)	45V1180E
12.4	-	-	2Q5V125(Q1)	25V1250SK	-	3R5V125(R1)	35V1250E	-	4R5V125(R1)	45V1250E
12.5	1B5V124(B)	2B5V124(B)	-	-	3B5V124(B)	-	-	4B5V124(B)	-	-
13.1	-	-	2Q5V132(Q1)	25V1320SF	-	3R5V132(R1)	35V1320E	-	4R5V132(R1)	45V1320E
13.7	1B5V136(B)	2B5V136(B)	-	-	3B5V136(B)	-	-	4B5V136(B)	-	-
13.9	-	-	2R5V140(R1)	25V1400SF	-	3R5V140(R1)	35V1400E	-	4R5V140(R1)	45V1400E
14.9	-	-	2R5V150(R1)	25V1500SF	-	3R5V150(R1)	35V1500E	-	4R5V150(R1)	45V1500E
15.5	1B5V154(B)	2B5V154(B)	-	-	3B5V154(B)	-	-	4B5V154(B)	-	-
15.9	-	-	2R5V160(R1)	25V1600SF	-	3R5V160(R1)	35V1600E	-	4R5V160(R1)	45V1600E
16.1	1B5V160(B)	2B5V160(B)	-	-	3B5V160(B)	-	-	4B5V160(B)	-	-
18.5	1B5V184(B)	2B5V184(B)	-	-	3B5V184(B)	-	-	4B5V184(B)	-	-
18.6	-	-	-	25V1870SF	-	-	35V1870E	-	-	45V1870E
20.1	1B5V200(B)	2B5V200(B)	-	-	3B5V200(B)	-	-	4B5V200(B)	-	-
21.1	-	-	2R5V212(R1)	25V2120SF	-	3R5V212(R1)	35V2120E	-	4S5V212(S1)	45V2120E
23.5	1B5V234(B)	2B5V234(B)	-	25V2360E	3B5V234(B)	-	35V2360E	4B5V234(B)	-	45V2360F
25.1	1B5V250(B)	2B5V250(B)	-	-	3B5V250(B)	-	-	4B5V250(B)	-	-
27.9	1B5V278(B)	2B5V278(B)	2R5V280(R1)	25V2800E	3B5V278(B)	3R5V280(R1)	35V3800E	4B5V278(B)	4S5V280(S1)	45V2800F
31.4	-	-	-	-	-	-	35V3150F	-	-	45V3150F
37.4	-	-	-	-	-	3S5V375(S1)	35V3750F	-	4S5V375(S1)	45V3750F
49.9	-	-	-	-	-	3U5V500(U0)	35V5000F	-	4U5V500(U0)	45V5000J

Letter suffix on part numbers for Q-D Sheaves indicates bushing size; bushing size is shown in parentheses for B5V and 5V Sheaves.



## STOCK SHEAVE LISTING

Table No.1

### 5 to 8 Groove "5V" Sheaves

Pitch Diameter	5 Grooves			6 Grooves			8 Grooves	
	5V Page 68	Q-D® Page 84	B5V® Page 47	5V Page 68	Q-D Page 84	B5V Page 47	5V Page 68	Q-D Page 85
4.3"	-	55V440SD	5B5V42(P2)	-	65V440SD	6B5V42(P2)	-	-
4.5	5Q5V46(Q2)	55V465SD	5B5V44(P2)	-	65V465SD	6B5V44(P2)	-	-
4.8	5Q5V49(Q2)	55V490SD	5B5V46(P2)	-	65V490SD	6B5V46(P2)	-	-
4.9	-	-	5B5V48(P2)	-	-	6B5V48(P2)	-	-
5.1	5Q5V52(Q2)	55V520SD	5B5V50(Q1)	-	65V520SD	6B5V50(Q2)	-	-
5.4	5Q5V55(Q2)	55V550SD	5B5V52(Q1)	-	65V550SD	6B5V52(Q2)	-	-
5.5	-	-	5B5V54(Q1)	-	-	6B5V54(Q2)	-	-
5.8	5Q5V59(Q2)	55V590SK	5B5V56(Q1)	-	65V590SK	6B5V56(Q2)	-	-
5.9	-	-	5B5V58(Q1)	-	-	6B5V58(Q1)	-	-
6.2	5Q5V63(Q2)	55V630SK	5B5V60(Q1)	-	65V630SK	6B5V60(Q1)	-	-
6.3	-	-	5B5V62(Q1)	-	-	6B5V62(Q1)	-	-
6.6	5Q5V67(Q2)	55V670SF	5B5V64(Q1)	-	65V670SF	6B5V64(Q1)	-	-
6.7	-	-	5B5V66(Q1)	-	-	6B5V66(Q1)	-	-
7.0	5Q5V71(Q2)	55V710SF	5B5V68(Q1)	6Q5V71(Q2)	65V710SF	6B5V68(Q1)	8Q5V71(Q2)	85V710SF
7.1	-	-	5B5V70(Q1)	-	-	6B5V70(Q2)	-	-
7.4	5Q5V75(Q2)	55V750SF	-	6Q5V75(Q2)	65V750SF	-	8Q5V75(Q2)	85V750SF
7.5	-	-	5B5V74(Q1)	-	-	6B5V74(Q2)	-	-
7.9	5R5V80(R1)	55V800E	-	6R5V80(R1)	65V800E	-	8R5V80(R2)	85V800E
8.1	-	-	5B5V80(R1)	-	-	6B5V80(R1)	-	-
8.4	5R5V85(R1)	55V850E	-	6R5V85(R1)	65V850E	-	8R5V85(R2)	85V850E
8.9	5R5V90(R1)	55V900E	5B5V86(R1)	6R5V90(R1)	65V900E	6B5V86(R1)	8R5V90(R2)	85V900E
9.2	5R5V92(R1)	55V925E	5B5V90(R1)	6R5V92(R1)	65V925E	6B5V90(R1)	8S5V92(S1)	85V925F
9.7	5R5V97(R1)	55V975E	5B5V94(R1)	6R5V97(R1)	65V975E	6B5V94(R1)	8S5V97(S1)	85V975F
10.2	5R5V103(R1)	55V1030E	-	6R5V103(R1)	65V1030E	-	8S5V103(S1)	85V1030F
10.8	5R5V109(R1)	55V1090E	-	6R5V109(R1)	65V1090E	-	8S5V109(S1)	85V1090F
11.1	-	-	5B5V110(R1)	-	-	6B5V110(R1)	-	-
11.2	-	55V1130E	-	-	65V1130E	-	-	85V1130F
11.7	5R5V118(R1)	55V1180E	-	6R5V118(R1)	65V1180E	-	8S5V118(S1)	85V1180F
12.4	5R5V125(R1)	55V1250E	-	6S5V125(S1)	65V1250E	-	8S5V125(S1)	85V1250F
12.5	-	-	5B5V124(R1)	-	-	6B5V124(R1)	-	-
13.1	5R5V132(R1)	55V1320E	-	6S5V132(S1)	65V1320F	-	8S5V132(S1)	85V1320F
13.9	5R5V140(R1)	55V1400E	5B5V136(R1)	6S5V140(S1)	65V1400F	6B5V136(R1)	8S5V140(S1)	85V1400F
14.9	5R5V150(R1)	55V1500E	-	6S5V150(S1)	65V1500F	-	8S5V150(S1)	85V1500F
15.5	-	-	5B5V154(R1)	-	-	6B5V154(R1)	-	-
15.9	5R5V160(R1)	55V1600E	-	6S5V160(S1)	65V1600F	-	8S5V160(S1)	85V1600F
16.1	-	-	5B5V160(R1)	-	-	6B5V160(R1)	-	-
18.5	-	-	5B5V184(R1)	-	-	6B5V184(R1)	-	-
18.6	-	55V1870F	-	-	65V1870F	-	-	85V1870J
20.1	-	-	5B5V200(R1)	-	-	6B5V200(R1)	-	-
21.1	5S5V212(S1)	55V2120F	-	6S5V212(S1)	65V2120F	-	8U5V212(U1)	85V2120J
23.5	-	55V2360F	-	-	65V2360J	-	-	85V2360J
24.9	5S5V250(S1)	-	-	6S5V250(S1)	-	-	8U5V250(U1)	-
25.1	-	-	5B5V250(R1)	-	-	6B5V250(R1)	-	-
27.9	5S5V280(S1)	55V2800F	-	6S5V280(S1)	65V2800J	-	8U5V280(U1)	85V2800J
31.4	-	55V3150J	-	-	65V3150J	-	-	85V3150M
37.4	5U5V375(U0)	55V3750J	-	6U5V375(U0)	65V3750J	-	8U5V375(U1)	85V3750M
49.9	5U5V500(U0)	55V5000J	-	6U5V500(U0)	65V5000M	-	8U5V500(U1)	85V5000M

Letter suffix on part numbers for Q-D Sheaves indicates bushing size; bushing size is shown in parentheses for B5V and 5V Sheaves.

For additional product information, visit [www.regalrexnord.com/Browning](http://www.regalrexnord.com/Browning)

# STOCK SHEAVE LISTING

Table No.1

4 to 8 Groove "8V" Sheaves

Datum Diameters	4 Grooves		5 Grooves		6 Grooves		8 Grooves	
	Split Taper Bushing Page 70	Q-D® Bushing Page 86	Split Taper Bushing Page 70	Q-D Bushing Page 86	Split Taper Bushing Page 70	Q-D Bushing Page 86	Split Taper Bushing Page 70	Q-D Bushing Page 87
12.3"	4S8V125(S1)	48V1250F	5S8V125(S1)	58V1250F	6S8V125(S1)	68V1250F	8S8V125(S2)	88V1250J
13.0	4S8V132(S1)	48V1320F	5S8V132(S1)	58V1320F	6S8V132(S1)	68V1320F	8S8V132(S2)	88V1320J
13.8	4S8V140(S1)	48V1400F	5S8V140(S1)	58V1400F	6S8V140(S1)	68V1400F	8S8V140(S2)	88V1400J
14.8	4S8V150(S1)	48V1500F	5S8V150(S1)	58V1500F	6S8V150(S1)	68V1500J	8S8V150(S2)	88V1500J
15.8	4S8V160(S1)	48V1600F	5S8V160(S1)	58V1600F	6S8V160(S1)	68V1600J	8S8V160(S20)	88V1600J
16.8	4S8V170(S1)	48V1700F	5S8V170(S1)	58V1700J	6S8V170(S1)	68V1700J	8U8V170(U1)	88V1700M
17.8	4S8V180(S1)	48V1800F	5S8V180(S1)	58V1800J	6S8V180(S1)	68V1800J	8U8V180(U1)	88V1800M
18.8	4S8V190(S1)	48V1900F	5S8V190(S1)	58V1900J	6S8V190(S1)	68V1900J	8U8V190(U1)	88V1900M
19.8	4S8V200(S1)	48V2000J	5S8V200(S1)	58V2000J	6S8V200(S1)	68V2000M	8U8V200(U1)	88V2000M
21.0	4S8V212(S1)	48V2120J	5S8V212(S1)	58V2120J	6S8V212(S1)	68V2120M	8U8V212(U1)	88V2120M
22.2	4U8V224(U0)	48V2240J	5U8V224(U0)	58V2240M	6U8V224(U0)	68V2240M	8U8V224(U1)	88V2240M
24.6	-	48V2480M	-	58V2480M	-	68V2480M	-	88V2480N
29.8	4U8V300(U0)	48V3000M	5U8V300(U0)	58V3000M	6U8V300(U0)	68V3000M	8U8V300(U1)	88V3000N
35.3	-	48V3550M	-	58V3550M	-	68V3550N	-	88V3550N
39.8	4U8V400(U0)	48V4000M	5U8V400(U0)	58V4000M	6U8V400(U0)	68V4000N	8W8V400(W1)	88V4000N
44.3	-	48V4550M	-	58V4550N	-	68V4550N	-	88V4550P
47.8	4U8V480(U0)	-	5U8V480(U0)	-	6U8V480(U0)	-	8W8V480(W1)	-
52.8	4U8V530(U0)	48V5300M	5U8V530(U0)	58V5300N	6U8V530(U0)	68V5300N	8W8V530(W1)	88V5300P
57.8	4U8V580(U0)	-	5U8V580(U0)	-	6U8V580(U0)	-	8W8V580(W1)	-
62.8	-	-	-	-	-	-	-	88V6300P
63.8	4U8V640(U0)	-	5U8V640(U0)	-	6U8V640(U0)	-	8W8V640(W1)	-

Table No.3  
Browning® Split Taper® Bushing Bores

Bushing	Bore Range (in.)	Bushing	Bore Range (in.)
G	3/8 - 1	S1	1 11/16 - 4 1/4
H	3/8 - 1 1/2	S2	1 7/8 - 4 3/16
P1	1/2 - 1 3/4	U0	2 3/8 - 5 1/2
B	1/2 - 2 7/16	U1	2 3/8 - 5 1/2
Q1	3/4 - 2 11/16	U2	2 7/16 - 5
Q2	1 - 2 5/8	W1	3 3/8 - 7 7/16
R1	1 1/8 - 3 3/4	W2	3 3/8 - 7 7/16
R2	1 3/8 - 3 5/8		

Table No.4  
Q-D® Bushing Bores

Bushing	Bore Range (in.)	Bushing	Bore Range (in.)
JA	1/2 - 1 1/4	E	7/8 - 3 1/2
SH	1/2 - 1 5/8	F	1 - 4
SDS	1/2 - 2	J	1 1/2 - 4 1/2
SD	1/2 - 2	M	2 - 5 1/2
SK	1/2 - 2 5/8	N	2 7/16 - 5 7/8
SF	1/2 - 2 15/16	P	2 15/16 - 7

# Browning®

## Bushings...

### **BROWNING® SPLIT TAPER® BUSHING**

- Solid flange to maintain concentric bores
- 3/4" taper per foot – self locking
- Double split barrel for positive clamping
- External key on most sizes for positive drive and greater torque carrying capabilities
- Available in inch, metric and spline bores
- Bore range from 3/8" to 7 7/16"

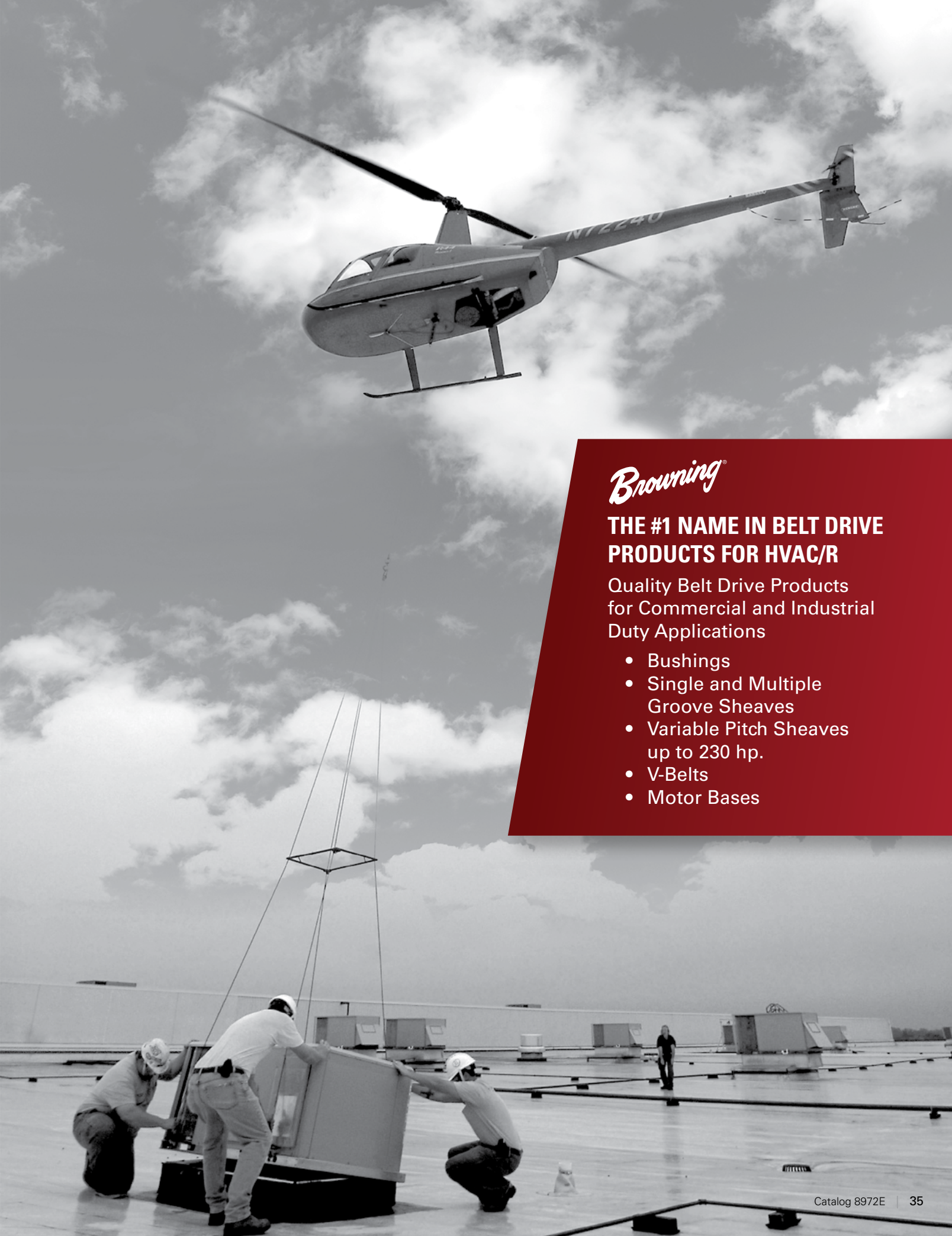

*Browning*<sup>®</sup>

**THE #1 NAME IN BELT DRIVE  
PRODUCTS FOR HVAC/R**

Quality Belt Drive Products  
for Commercial and Industrial  
Duty Applications

- Bushings
- Single and Multiple Groove Sheaves
- Variable Pitch Sheaves up to 230 hp.
- V-Belts
- Motor Bases

### AK CAST IRON SHEAVES

#### Single Groove Sheaves for "4L" or "A" Belts

"3L" Belts may also be used with these sheaves as indicated in the table below.

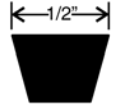

Table No.1

Stock Sizes - Finished Bore

Part No.	DIAMETERS			Type	STOCK BORES MARKED "X" (in.)											DIMENSIONS				Wt. Lbs.
	Outside	Datum "A"	Pitch "3L"		1/2	5/8	3/4	7/8	15/16	1	1 1/8	1 3/16	1 1/4	1 3/8	1 7/16	F	L	P	C	
▲ AK17	1.75	1.50	1.16	1	X	X	-	-	-	-	-	-	-	-	-	0.75	1.12	0.48	0.11	.2
▲ AK20	2.00	1.80	1.46	1	X	X	X	-	-	-	-	-	-	-	-	0.75	1.11	0.48	0.12	.3
▲ AK21	2.10	1.90	1.56	1	X	X	X	-	-	-	-	-	-	-	-	0.75	1.07	0.48	0.16	.4
▲ AK22	2.20	2.00	1.66	1	X	X	X	-	-	-	-	-	-	-	-	0.75	1.07	0.48	0.16	.5
▲ AK23	2.30	2.10	1.76	1	X	X	X	-	-	-	-	-	-	-	-	0.75	1.07	0.48	0.16	.5
▲ AK25	2.50	2.30	1.96	2	X	X	X	-	-	-	-	-	-	-	-	0.75	1.07	0.48	0.16	.5
▲ AK26	2.60	2.40	2.06	2	X	X	X	-	-	-	-	-	-	-	-	0.75	1.07	0.48	0.16	.5
▲ AK27	2.70	2.50	2.16	2	X	X	X	-	-	-	-	-	-	-	-	0.75	1.07	0.48	0.16	.6
▲ AK28	2.80	2.60	2.26	2	X	X	X	-	-	-	-	-	-	-	-	0.75	1.07	0.48	0.16	.7
▲ AK30	3.05	2.80	2.46	2	X	X	X	X	-	-	-	-	-	-	-	0.75	1.07	0.48	0.16	.7
▲ AK32	3.25	3.00	2.66	2	X	X	X	X	-	-	-	-	-	-	-	0.75	1.07	0.48	0.16	.7
▲ AK34	3.45	3.20	2.86	2	X	X	X	X	-	-	-	-	-	-	-	0.75	1.07	0.48	0.16	.9
AK39	3.75	3.50	3.16	2	X	X	X	X	X	-	-	-	-	-	-	0.75	1.16	0.47	0.06	1.4
AK41	3.95	3.70	3.36	2	X	X	X	X	X	-	-	-	-	-	-	0.75	1.16	0.47	0.06	1.5
AK44	4.25	4.00	3.66	3	X	X	X	X	X	X	-	-	-	-	-	0.75	1.16	0.47	0.06	1.5
AK46	4.45	4.20	3.86	3	X	X	X	X	X	X	-	-	-	-	-	0.75	1.16	0.47	0.06	1.5
AK49	4.75	4.50	4.16	3	X	X	X	X	X	X	-	-	-	-	-	0.75	1.16	0.47	0.06	1.7
AK51	4.95	4.70	4.36	3	X	X	X	X	X	X	-	-	-	-	-	0.75	1.16	0.47	0.06	1.7
AK54	5.25	5.00	4.66	3	X	X	X	X	X	X	X	-	-	-	-	0.75	1.16	0.47	0.06	1.8
AK56	5.45	5.20	4.86	3	X	X	X	X	X	X	X	-	-	-	-	0.75	1.16	0.47	0.06	1.9
AK59	5.75	5.50	5.16	3	X	X	X	X	X	X	X	-	-	-	-	0.75	1.16	0.47	0.06	2.0
AK61	5.95	5.70	5.36	3	X	X	X	X	X	X	X	-	-	-	-	0.75	1.16	0.47	0.06	2.1
AK64	6.25	6.00	5.66	3	X	X	X	X	X	X	X	-	-	-	-	0.75	1.16	0.47	0.06	2.2
AK66	6.45	6.20	5.86	3	-	X	X	-	-	X	X	-	-	-	-	0.75	1.16	0.47	0.06	2.3
AK69	6.75	6.50	6.16	3	-	-	X	-	-	X	X	-	-	-	-	0.75	1.469	0.72	0	3.5
AK71	6.95	6.70	6.36	3	-	X	X	-	-	X	X	-	-	X	-	0.75	1.469	0.72	0	3.8
▲ AK74	7.25	7.00	6.66	3	X	X	X	-	X	X	X	X	-	X	-	0.75	1.531 1.469	0.78 0.72	0.06 0	3.4
▲ AK79	7.75	7.50	7.16	3	-	-	X	-	-	X	X	-	-	X	-	0.75	1.469	0.72	0	4.0
▲ AK84	8.25	8.00	7.66	3	X	X	X	-	X	X	X	-	-	X	-	0.75	1.469	0.72	0	3.8
▲ AK89	8.75	8.50	8.16	3	-	-	X	-	-	X	X	-	-	X	-	0.75	1.469	0.72	0	4.3
▲ AK94	9.25	9.00	8.66	3	X	X	X	-	X	X	-	X	-	X	-	0.75	1.47 1.469	0.78 0.72	0.06 0	4.5
▲ AK99	9.75	9.50	9.16	3	-	-	X	-	-	X	-	-	-	X	-	0.75	1.469	0.72	0	5.3
▲ AK104	10.25	10.00	9.66	3	-	X	X	-	-	X	-	X	-	X	-	0.75	1.469	0.72	0	5.1
▲ AK109	10.75	10.50	10.16	3	-	-	X	-	-	X	-	-	-	X	-	0.75	1.469	0.72	0	5.8
▲ AK114	11.25	11.00	10.66	3	-	-	X	-	-	X	-	-	-	X	-	0.75	1.469	0.72	0	5.6
▲ AK124	12.25	12.00	11.66	3	-	X	X	-	-	X	-	X	-	X	-	0.75	1.531 1.469	0.78 0.72	0.06 0	6.5
AK134	13.25	13.00	12.66	3	-	-	X	-	-	X	-	-	-	X	-	0.75	1.469	0.72	0	7.5
AK144	14.25	14.00	13.66	3	-	-	X	-	-	X	-	-	-	X	-	0.75	1.471	0.72	0	8.5
AK154	15.25	15.00	14.66	3	-	-	X	-	-	X	-	-	-	X	-	0.75	1.469	0.72	0	9.8
AK184	18.25	18.00	17.66	3	-	-	X	-	-	X	-	-	-	X	-	0.75	1.469	0.72	0	12.1

▲ Note: Do not use these "AK" Sheaves with bores 1" and under with Gripotch® belt ratings.

Table No.2  
Standard Keyseats

Bore Range (in.)	Keyseat (in.)
1/2	None
5/8 to 7/8	3/16 x 3/32
15/16 to 1 1/4	1/4 x 1/8
1 7/16	3/8 x 3/16

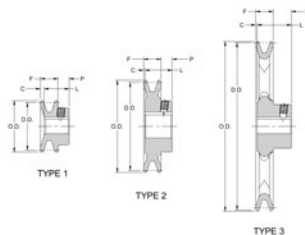

The extensive Browning® V-drive line means maximum economy, versatility and prompt availability for your every application - truly the right drive every time...for every service.

Browning "AK" Sheaves are accurately machined from fine grained cast iron, statically balanced, painted and individually packaged. They are furnished with standard keyseats and hollow head setscrews.

## AKH CAST IRON SHEAVES

Single Groove Sheaves for "4L" or "A" Belts  
 "3L" Belts may also be used with these sheaves as indicated in the table below.



Table No.1 Stock Sizes with Browning® Split Taper® Bushings

Part No.	DIAMETER (in.)			Type	DIMENSIONS								Wt. Less Bush
	O.D.	Datum "A"	Pitch "3L"		O.L.	F	L	P	C	X	G	F	
AK30H	3.05	2.80	2.46	1	1.78	0.75	1.28	0.88	-	1.19	0.44	0.16	1.12
AK32H	3.25	3.00	2.66	1	1.78	0.75	1.28	0.88	-	1.19	0.44	0.16	1.35
AK34H	3.45	3.20	2.86	1	1.47	0.75	1.28	0.56	-	0.88	0.44	0.16	1.25
AK39H	3.75	3.50	3.16	1	1.47	0.75	1.28	0.56	-	0.88	0.44	0.16	1.44
AK41H	3.95	3.70	3.36	1	1.47	0.75	1.28	0.56	-	0.88	0.44	0.16	1.64
AK44H	4.25	4.00	3.66	1	1.47	0.75	1.28	0.56	-	0.88	0.44	0.16	1.64
AK46H	4.45	4.20	3.86	2	1.47	0.75	1.28	0.56	-	0.88	0.44	0.16	2.20
AK49H	4.75	4.50	4.16	2	1.47	0.75	1.28	0.56	-	0.88	0.44	0.16	2.10
AK51H	4.95	4.70	4.36	2	1.47	0.75	1.28	0.56	-	0.88	0.44	0.16	2.35
AK54H	5.25	5.00	4.66	2	1.47	0.75	1.28	0.56	-	0.88	0.44	0.16	2.62
AK56H	5.45	5.20	4.86	2	1.47	0.75	1.28	0.56	-	0.88	0.44	0.16	2.34
AK59H	5.75	5.50	5.16	3	1.47	0.75	1.28	0.56	-	0.88	0.44	0.16	2.54
AK61H	5.95	5.70	5.36	3	1.47	0.75	1.28	0.56	-	0.88	0.44	0.16	2.35
AK64H	6.25	6.00	5.66	3	1.47	0.75	1.28	0.56	-	0.88	0.44	0.16	2.60
AK66H	6.45	6.20	5.86	3	1.47	0.75	1.28	0.56	-	0.88	0.44	0.16	2.67
AK69H	6.75	6.50	6.16	3	1.47	0.75	1.28	0.56	-	0.88	0.44	0.16	3.00
AK71H	6.95	6.70	6.36	3	1.47	0.75	1.28	0.56	-	0.88	0.44	0.16	3.55
AK74H	7.25	7.00	6.66	3	1.47	0.75	1.28	0.56	-	0.88	0.44	0.16	3.12
AK79H	7.75	7.50	7.16	3	1.47	0.75	1.28	0.56	-	0.88	0.44	0.16	3.45
AK84H	8.25	8.00	7.66	3	1.47	0.75	1.28	0.56	-	0.88	0.44	0.16	4.24
AK89H	8.75	8.50	8.16	3	1.47	0.75	1.28	0.56	-	0.88	0.44	0.16	4.50
AK94H	9.25	9.00	8.66	3	1.47	0.75	1.28	0.56	-	0.88	0.44	0.16	5.17
AK99H	9.75	9.50	9.16	3	1.47	0.75	1.28	0.56	-	0.88	0.44	0.16	5.60
AK104H	10.25	10.00	9.66	3	1.47	0.75	1.28	0.56	-	0.88	0.44	0.16	5.91
AK109H	10.75	10.50	10.16	3	1.47	0.75	1.28	0.56	-	0.88	0.44	0.16	6.29
AK114H	11.25	11.00	10.66	3	1.47	0.75	1.28	0.56	-	0.88	0.44	0.16	6.67
AK124H	12.25	12.00	11.66	3	1.47	0.75	1.28	0.56	-	0.88	0.44	0.16	7.57
AK134H	13.25	13.00	12.66	3	1.47	0.75	1.28	0.56	-	0.88	0.44	0.16	8.15
AK144H	14.25	14.00	13.66	3	1.47	0.75	1.28	0.56	-	0.88	0.44	0.16	7.83
AK154H	15.25	15.00	14.66	3	1.47	0.75	1.28	0.44	-	0.88	0.44	0.16	9.57
AK184H	18.25	18.00	17.66	3	1.47	0.75	1.28	0.56	-	0.88	0.44	0.16	12.34

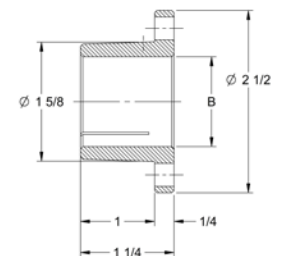
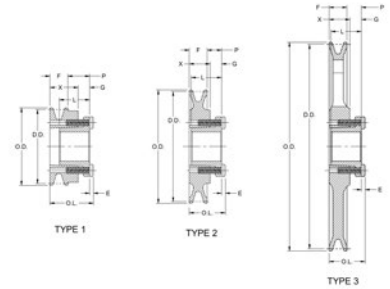

### Browning Split Taper Bushings

- Highest torque carrying capacity in the Browning bushing product line
- Double split barrel assures true concentricity
- Inch, metric and spline bores available from stock

Table No.2 H bushing

Bushing	L	U	T	D		H	V	W	X	Y	R	S	Bore Range (in.)		Cap Screws		Avg. Wt. Lbs	Wrench Torque in-lbs	Capscrew Head Projection
				Large End	Small End								Type 1	Type 2	No.	Size			
				H	1 1/4								1/4	1	1.625	1.571			

For additional product information, visit [www.regalrexnord.com/Browning](http://www.regalrexnord.com/Browning)

### 2AK CAST IRON SHEAVES

Two Groove Sheaves for "4L" or "A" Belts

"3L" Belts may also be used with these sheaves as indicated in the table below.

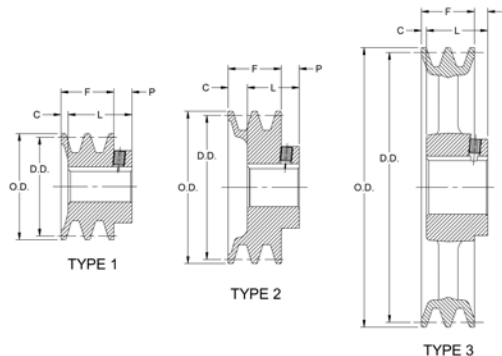

Table No.1 Stock Sizes - Finished Bore

Part No.	DIAMETERS			Type	STOCK BORES MARKED "X" (in.)										DIMENSIONS				Wt. Lbs.
	Outside	Datum "A"	Pitch "3L"		1/2	5/8	3/4	7/8	15/16	1	1 1/8	1 3/16	1 3/8	1 7/16	F	L	P	C	
2AK20	2.00	1.80	1.46	1	X	X	X	-	-	-	-	-	-	-	1.375	1.66	0.47	0.19	0.89
2AK21	2.15	1.90	1.56	1	X	X	X	-	-	-	-	-	-	-	1.375	1.66	0.47	0.19	0.88
2AK22	2.25	2.00	1.66	1	X	X	X	X	-	-	-	-	-	-	1.375	1.66	0.47	0.19	1
2AK23	2.35	2.10	1.76	1	-	X	-	X	-	X	-	-	-	-	1.375	1.66	0.47	0.19	1.15
2AK25	2.55	2.30	1.96	1	-	X	X	X	-	X	-	-	-	-	1.375	1.66	0.47	0.19	1.23
2AK26	2.65	2.40	2.06	1	-	X	X	X	-	X	-	-	-	-	1.375	1.66	0.47	0.19	1.55
2AK27	2.75	2.50	2.16	1	-	X	X	X	-	X	-	-	-	-	1.375	1.66	0.47	0.19	1.6
2AK28	2.85	2.60	2.26	1	-	X	X	X	-	X	-	-	-	-	1.375	1.66	0.47	0.19	1.8
2AK30	3.05	2.80	2.46	1	X	X	X	X	-	X	X	-	-	-	1.375	1.66	0.47	0.19	2
2AK32	3.25	3.00	2.66	1	-	X	X	X	-	X	X	-	-	-	1.375	1.66	0.47	0.19	2.2
2AK34	3.45	3.20	2.86	1	-	X	X	X	-	X	X	-	-	-	1.375	1.65	0.47	0.19	2.45
2AK39	3.75	3.50	3.16	2	-	X	X	X	-	X	X	-	-	-	1.375	1.34	0.47	0.5	2.04
2AK41	3.95	3.70	3.36	2	-	X	X	X	-	X	X	-	-	-	1.375	1.34	0.47	0.5	2.95
2AK44	4.25	4.00	3.66	2	-	X	X	X	-	X	X	-	-	-	1.375	1.34	0.47	0.5	3.15
2AK46	4.45	4.20	3.86	2	-	-	-	X	-	X	X	-	-	-	1.375	1.34	0.47	0.5	3.93
2AK49	4.75	4.50	4.16	2	-	-	X	X	-	X	X	-	X	-	1.375	1.34	0.47	0.5	3.83
2AK51	4.95	4.70	4.36	2	-	-	X	X	-	X	X	-	X	-	1.375	1.34	0.47	0.5	4.45
2AK54	5.25	5.00	4.66	3	-	X	X	X	-	X	X	-	X	-	1.375	1.34	0.47	0.5	3.72
2AK56	5.45	5.20	4.86	3	-	X	X	-	-	X	X	-	X	-	1.375	1.34	0.47	0.5	3.75
2AK59	5.75	5.50	5.16	3	-	-	-	-	-	X	X	-	X	-	1.375	1.34	0.47	0.5	3.97
2AK61	5.95	5.70	5.36	3	-	-	X	X	-	X	X	-	X	-	1.375	1.34	0.47	0.5	3.95
2AK64	6.25	6.00	5.66	3	-	-	X	-	-	X	X	X	X	X	1.375	1.59	0.34	0.13	4.97
2AK74	7.25	7.00	6.66	3	-	-	X	-	-	X	X	X	X	X	1.375	1.59	0.34	0.13	5.41
2AK84	8.25	8.00	7.66	3	-	-	X	-	X	X	X	X	X	X	1.375	1.59	0.34	0.13	7.6
2AK94	9.25	9.00	8.66	3	-	-	X	-	-	X	X	X	X	X	1.375	1.59	0.34	0.13	7.48
2AK104	10.25	10.00	9.66	3	-	-	X	-	X	X	-	X	-	X	1.375	1.59	0.34	0.13	8.99
2AK114	11.25	11.00	10.66	3	-	-	X	-	-	X	-	X	X	X	1.375	1.59	0.34	0.12	8.92
2AK124	12.25	12.00	11.66	3	-	-	X	-	-	X	-	X	-	X	1.375	1.59	0.34	0.13	11.52
2AK134	13.25	13.00	12.66	3	-	-	-	-	-	-	-	X	-	X	1.375	1.59	0.34	0.13	11.88
2AK144	14.25	14.00	13.66	3	-	-	-	-	-	X	-	-	-	X	1.375	1.59	0.34	0.13	11.17
2AK154	15.25	15.00	14.66	3	-	-	-	-	-	-	-	X	-	X	1.375	1.59	0.53	0.32	14.22
2AK184	18.25	18.00	17.66	3	-	-	-	-	-	-	-	X	-	X	1.375	1.59	0.53	0.31	18.33

Table No.2 Standard Keyseats

Bore Range (in.)	Keyseat (in.)
1/2	None
5/8 to 7/8	3/16 x 3/32
15/16 to 1 1/4	1/4 x 1/8
1 7/16	3/8 x 3/16



The extensive Browning® V-drive line means maximum economy, versatility and prompt availability for your every application - truly the right drive every time...for every service.

## 2AKH CAST IRON SHEAVES

Two Groove Sheaves for "4L" or "A" Belts

"3L" Belts may also be used with these sheaves as indicated in the table below.



**Table No.1 Stock Sizes with Browning® Split Taper® Bushings**

Part No.	DIAMETER			Type	DIMENSIONS								Wt. Less Bush
	O.D.	Datum "A"	Pitch "3L"		O.L.	F	L	P	C	X	G	E	
2AK30H	3.05	2.80	2.46	1	2.40	1.38	1.25	0.87	0.94	0.88	0.43	0.16	1.62
2AK32H	3.25	3.00	2.66	1	2.40	1.38	1.25	0.87	0.94	0.88	0.43	0.16	1.88
2AK34H	3.45	3.20	2.86	1	1.97	1.38	1.25	0.43	0.50	0.88	0.43	0.16	1.52
2AK39H	3.75	3.50	3.16	1	1.97	1.38	1.25	0.43	0.50	0.88	0.43	0.16	1.90
2AK41H	3.95	3.70	3.36	2	1.47	1.38	1.25	-0.07	-	0.88	0.43	0.16	2.09
2AK44H	4.25	4.00	3.66	2	1.47	1.38	1.25	-0.07	-	0.88	0.43	0.16	2.59
2AK46H	4.45	4.20	3.86	2	1.47	1.38	1.25	-0.07	-	0.88	0.43	0.16	2.64
2AK49H	4.75	4.50	4.16	2	1.47	1.38	1.25	-0.07	-	0.88	0.43	0.16	3.13
2AK51H	4.95	4.70	4.36	2	1.47	1.38	1.25	-0.07	-	0.88	0.43	0.16	3.28
2AK54H	5.25	5.00	4.66	2	1.47	1.38	1.25	-0.07	-	0.88	0.43	0.16	3.29
2AK56H	5.45	5.20	4.86	2	1.47	1.38	1.25	-0.07	-	0.88	0.43	0.16	3.42
2AK59H	5.75	5.50	5.16	3	1.47	1.38	1.25	-0.07	-	0.88	0.43	0.16	3.52
2AK61H	5.95	5.70	5.36	3	1.47	1.38	1.25	-0.07	-	0.88	0.43	0.16	3.43
2AK64H	6.25	6.00	5.66	3	1.47	1.38	1.25	-0.07	-	0.88	0.43	0.16	3.89
2AK74H	7.25	7.00	6.66	3	1.47	1.38	1.25	-0.07	-	0.88	0.43	0.16	4.38
2AK84H	8.25	8.00	7.66	3	1.47	1.38	1.25	-0.07	-	0.88	0.43	0.16	5.99
2AK94H	9.25	9.00	8.66	3	1.47	1.38	1.25	-0.07	-	0.88	0.43	0.16	7.28
2AK104H	10.25	10.00	9.66	3	1.47	1.38	1.25	-0.07	-	0.88	0.43	0.16	8.40
2AK114H	11.25	11.00	10.66	3	1.47	1.38	1.25	-0.07	-	0.88	0.43	0.16	8.96
2AK124H	12.25	12.00	11.66	3	1.47	1.38	1.25	-0.07	-	0.88	0.43	0.16	10.21
2AK134H	13.25	13.00	12.66	3	1.47	1.38	1.25	-0.07	-	0.88	0.43	0.16	11.17
2AK144H	14.25	14.00	13.66	3	1.47	1.38	1.25	-0.06	-	0.88	0.43	0.16	12.21
2AK154H	15.25	15.00	14.66	3	1.46	1.38	1.25	-0.07	-	0.87	0.43	0.16	14.00
2AK184H	18.25	18.00	17.66	3	1.46	1.38	1.25	-0.07	-	0.87	0.43	0.16	14.54



### Browning Split Taper Bushings

- Highest torque carrying capacity in the Browning bushing product line
- Double split barrel assures true concentricity
- Inch, metric and spline bores available from stock

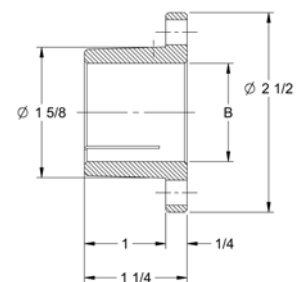
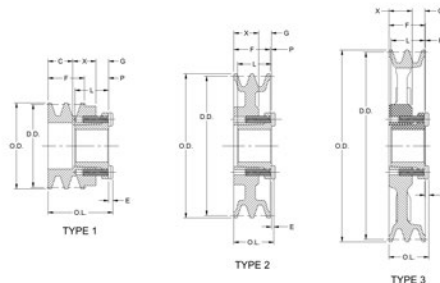

**Table No.2 H bushing**

Bushing	L	U	T	D		H	V	W	X	Y	R	S	Bore Range (in.)		Cap Screws		Avg. Wt. Lbs	Wrench Torque in-lbs	Capscrew Head Projection
				Large End	Small End								Type 1	Type 2	No.	Size			
				H	1 1/4								1/4	1	1.625	1.571			

For additional product information, visit [www.regalrexnord.com/Browning](http://www.regalrexnord.com/Browning)

### BK CAST IRON SHEAVES

Single Groove Sheaves  
Combination Groove  
for "4L" or "A" Belts and "5L" or "B" Belts



Table No.1 Stock Sizes - Finished Bore

Part No.	DIAMETER			Type	STOCK BORES MARKED "X" (in.)											DIMENSIONS				Wt. Lbs.
	Outside	Datum "A"	Datum "B"		1/2	5/8	3/4	7/8	15/16	1	1 1/8	1 3/16	1 1/4	1 3/8	1 7/16	F	L	P	C	
▲BK24	2.40	1.80	2.20	1	X	X	X	-	-	-	-	-	-	-	0.88	1.16	0.44	0.16	0.69	
▲BK25	2.50	1.90	2.30	1	X	X	X	X	-	-	-	-	-	-	0.88	1.16	0.44	0.16	0.74	
▲BK26	2.60	2.00	2.40	1	X	X	X	X	-	-	-	-	-	-	0.88	1.16	0.44	0.16	0.8	
▲BK27	2.70	2.10	2.50	2	X	X	X	X	-	-	-	-	-	-	0.88	1.16	0.44	0.16	0.86	
▲BK28	2.95	2.20	2.60	2	X	X	X	X	-	-	-	-	-	-	0.88	1.16	0.44	0.16	1.03	
▲BK30	3.15	2.40	2.80	2	X	X	X	X	-	-	-	-	-	-	0.88	1.16	0.44	0.16	1.17	
▲BK32	3.35	2.60	3.00	2	X	X	X	X	-	-	-	-	-	-	0.88	1.16	0.44	0.15	1.28	
BK34	3.55	2.80	3.20	2	X	X	X	X	-	X	X	-	-	-	0.88	1.16	0.41	0.13	1.5	
BK36	3.75	3.00	3.40	2	X	X	X	X	-	X	X	-	-	-	0.88	1.16	0.41	0.12	1.7	
BK40	3.95	3.20	3.60	2	X	X	X	X	-	X	X	-	-	-	0.88	1.15	0.41	0.13	1.81	
BK45	4.25	3.50	3.90	2	X	X	X	X	-	X	X	-	-	-	0.88	1.16	0.41	0.13	2.01	
BK47	4.45	3.70	4.10	2	X	X	X	X	-	X	X	-	-	-	0.88	1.16	0.41	0.12	2.35	
BK50	4.75	4.00	4.40	3	X	X	X	X	X	X	x	-	-	-	0.88	1.16	0.41	0.12	2.29	
BK52	4.95	4.20	4.60	3	X	X	X	X	-	X	X	-	-	-	0.88	1.16	0.41	0.13	2.23	
BK55	5.25	4.50	4.90	3	X	X	X	X	-	X	X	X	-	-	0.88	1.16	0.41	0.12	2.6	
BK57	5.45	4.70	5.10	3	-	X	X	X	X	X	X	-	-	-	0.88	1.16	0.41	0.12	2.54	
BK60	5.75	5.00	5.40	3	X	X	X	X	-	X	X	X	-	-	0.88	1.16	0.41	0.13	3.04	
BK62	5.95	5.20	5.60	3	X	X	X	X	X	X	X	X	-	-	0.88	1.16	0.41	0.13	2.98	
BK65	6.25	5.50	5.90	3	-	X	X	-	-	X	X	-	-	-	0.88	1.16	0.41	0.13	3.16	
BK67	6.45	5.70	6.10	3	-	X	X	-	-	X	X	-	-	-	0.88	1.16	0.41	0.13	3.73	
BK70	6.75	6.00	6.40	3	-	X	X	-	X	X	X	-	-	X	0.88	1.47	0.66	0.06	4.28	
																1.16	0.41	0.13	3.39	
BK72	6.95	6.20	6.60	3	-	-	X	-	-	X	X	-	-	X	0.88	1.47	0.66	0.06	4.44	
BK75	7.25	6.50	6.90	3	-	-	X	-	-	X	X	-	-	X	0.88	1.47	0.66	0.06	4.1	
BK77	7.45	6.70	7.10	3	-	-	X	-	-	X	X	-	-	X	0.88	1.47	0.66	0.06	5.31	
BK80	7.75	7.00	7.40	3	-	X	X	X	-	X	X	X	X	X	0.88	1.47	0.66	0.06	5.01	
BK85	8.25	7.50	7.90	3	-	-	X	-	-	X	X	-	-	X	0.88	1.47	0.66	0.06	5.59	
BK90	8.75	8.00	8.40	3	-	-	X	X	X	X	X	X	-	X	0.88	1.47	0.66	0.06	6.02	
BK95	9.25	8.50	8.90	3	-	-	X	-	-	X	X	-	-	X	0.88	1.47	0.66	0.06	6.77	
BK100	9.75	9.00	9.40	3	-	-	X	X	-	X	X	X	X	x	0.88	1.47	0.66	0.06	5.99	
BK105	10.25	9.50	9.90	3	-	-	-	-	-	X	-	-	-	X	0.88	1.47	0.66	0.06	7.15	
BK110	10.75	10.00	10.40	3	-	-	X	-	-	X	X	X	-	X	0.88	1.47	0.66	0.06	8.07	
BK115	11.25	10.50	10.90	3	-	-	-	-	-	X	-	-	-	X	0.88	1.47	0.66	0.06	8.29	
BK120	11.75	11.00	11.40	3	-	-	X	-	-	X	-	-	-	X	0.88	1.47	0.66	0.06	8.79	
BK130	12.75	12.00	12.40	3	-	-	X	-	-	X	X	X	-	-	0.88	1.47	0.66	0.06	10.62	
BK140	13.75	13.00	13.40	3	-	-	X	-	-	X	-	X	-	-	0.88	1.47	0.66	0.06	10.16	
BK160	15.75	15.00	15.40	3	-	-	-	-	-	X	X	X	X	-	0.88	1.47	0.66	0.06	13.7	
BK190	18.75	18.00	18.40	3	-	-	-	-	-	X	-	X	X	-	0.88	1.47	0.66	0.06	16.19	

▲ Note: Do not use these "BK" Sheaves with "B" Gripnotch® belt ratings.

Table No.2 Standard Keyseats

Bore Range (in.)	Keyseat (in.)
1/2"	None
5/8 to 7/8	3/16 x 3/32
15/16 to 1 1/4	1/4 x 1/8
1 7/16	3/8 x 3/16

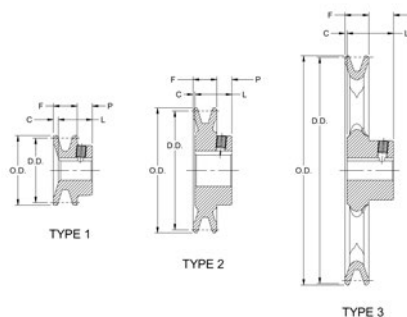

The extensive Browning® V-drive line means maximum economy, versatility and prompt availability for your every application - truly the right drive every time...for every service.

## BKH CAST IRON SHEAVES

Single Groove Sheaves  
Combination Groove  
for "4L" or "A" Belts and "5L" or "B" Belts



Table No.1 Stock Sizes with Browning® Split Taper® Bushings

Part No.	DIAMETER			Type	DIMENSIONS								Wt. Less Bush
	O.D.	Datum "A"	Datum "B"		O.L.	F	L	P	C	X	G	E	
BK30H	3.15	2.40	2.80	1	1.91	0.88	1.28	0.87	-	1.31	0.44	0.16	1.24
BK32H	3.35	2.60	3.00	1	1.91	0.88	1.28	0.87	-	1.31	0.44	0.16	1.42
BK34H	3.55	2.80	3.20	1	1.91	0.88	1.28	0.87	-	1.31	0.44	0.16	1.61
BK36H	3.75	3.00	3.40	1	1.47	0.88	1.28	0.44	-	0.88	0.44	0.16	1.25
BK40H	3.95	3.20	3.60	1	1.47	0.88	1.28	0.44	-	0.88	0.44	0.16	1.47
BK45H	4.25	3.50	3.90	1	1.47	0.88	1.28	0.44	-	0.88	0.44	0.16	1.83
BK47H	4.45	3.70	4.10	1	1.47	0.88	1.28	0.44	-	0.88	0.44	0.16	2.08
BK50H	4.75	4.00	4.40	2	1.47	0.88	1.28	0.44	-	0.88	0.44	0.16	2.25
BK52H	4.95	4.20	4.60	2	1.47	0.88	1.28	0.44	-	0.88	0.44	0.16	2.56
BK55H	5.25	4.50	4.90	2	1.47	0.88	1.28	0.44	-	0.88	0.44	0.16	2.66
BK57H	5.45	4.70	5.10	2	1.47	0.88	1.28	0.44	-	0.88	0.44	0.16	3.06
BK60H	5.75	5.00	5.40	2	1.47	0.88	1.28	0.44	-	0.88	0.44	0.16	3.30
BK62H	5.95	5.20	5.60	2	1.47	0.88	1.28	0.44	-	0.88	0.44	0.16	3.41
BK65H	6.25	5.50	5.90	2	1.47	0.88	1.28	0.44	-	0.88	0.44	0.16	3.09
BK67H	6.45	5.70	6.10	2	1.47	0.88	1.28	0.44	-	0.88	0.44	0.16	3.90
BK70H	6.75	6.00	6.40	3	1.53	0.88	1.28	0.50	-	0.88	0.44	0.16	3.89
BK72H	6.95	6.20	6.60	3	1.53	0.88	1.28	0.50	0.06	0.88	0.44	0.16	4.00
BK75H	7.25	6.50	6.90	3	1.53	0.88	1.28	0.50	0.06	0.88	0.44	0.16	3.57
BK77H	7.45	6.70	7.10	3	1.53	0.88	1.28	0.50	0.06	0.88	0.44	0.16	4.48
BK80H	7.75	7.00	7.40	3	1.53	0.88	1.28	0.50	0.06	0.88	0.44	0.16	4.50
BK85H	8.25	7.50	7.90	3	1.53	0.88	1.28	0.50	0.06	0.88	0.44	0.16	4.87
BK90H	8.75	8.00	8.40	3	1.53	0.88	1.28	0.50	0.06	0.87	0.44	0.16	5.43
BK95H	9.25	8.50	8.90	3	1.53	0.88	1.28	0.50	0.06	0.88	0.44	0.16	5.83
BK100H	9.75	9.00	9.40	3	1.53	0.88	1.28	0.50	0.06	0.88	0.44	0.16	6.38
BK105H	10.25	9.50	9.90	3	1.53	0.88	1.28	0.50	0.06	0.88	0.44	0.16	6.68
BK110H	10.75	10.00	10.40	3	1.53	0.88	1.28	0.50	0.06	0.88	0.44	0.16	7.17
BK115H	11.25	10.50	10.90	3	1.53	0.88	1.28	0.50	0.06	0.88	0.44	0.16	7.01
BK120H	11.75	11.00	11.40	3	1.53	0.88	1.28	0.50	0.06	0.88	0.44	0.16	8.34
BK130H	12.75	12.00	12.40	3	1.53	0.88	1.28	0.50	0.06	0.88	0.44	0.16	7.99
BK140H	13.75	13.00	13.40	3	1.53	0.88	1.28	0.50	0.06	0.88	0.44	0.16	9.50
BK150H	14.75	14.00	14.40	3	1.53	0.88	1.28	0.50	0.06	0.88	0.44	0.16	10.35
BK160H	15.75	15.00	15.40	3	1.53	0.88	1.28	0.50	0.06	0.88	0.44	0.16	11.11
BK190H	18.75	18.00	18.40	3	1.53	0.88	1.28	0.50	0.06	0.88	0.44	0.16	14.45

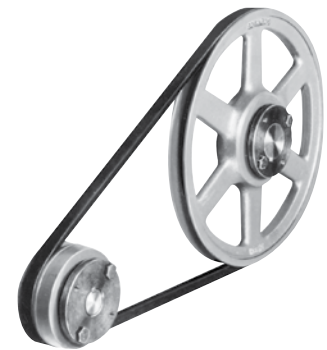
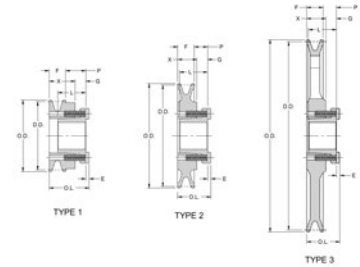

### Browning Split Taper Bushings

- Highest torque carrying capacity in the Browning bushing product line
- Double split barrel assures true concentricity
- Inch, metric and spline bores available from stock

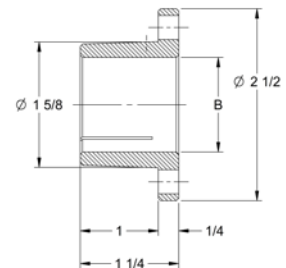

Table No.2 H bushing

Bushing	L	U	T	D		H	V	W	X	Y	R	S	Bore Range (in.)		Cap Screws		Avg. Wt. Lbs	Wrench Torque in-lbs	Capscrew Head Projection
				Large End	Small End								Type 1	Type 2	No.	Size			
				H	1 1/4								1/4	1	1.625	1.571			

For additional product information, visit [www.regalrexnord.com/Browning](http://www.regalrexnord.com/Browning)

### 2BK CAST IRON SHEAVES

Two Groove Sheaves  
Combination Groove  
for "4L" or "A" Belts and "5L" or "B" Belts

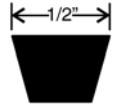

Table No.1

Stock Sizes - Finished Bore

Part No.	DIAMETERS			Type	STOCK BORES MARKED "X" (in.)									DIMENSIONS				Wt. Lbs.
	Outside	Datum "A"	Datum "B"		1/2	5/8	3/4	7/8	1	1 1/8	1 3/16	1 3/8	1 7/16	F	L	P	C	
2BK25	2.50	1.90	2.30	1	X	X	X	X	-	-	-	-	-	1.75	1.97	0.47	0.25	1.56
2BK27	2.70	2.10	2.50	1	X	X	X	X	X	-	-	-	-	1.75	1.97	0.47	0.25	2.01
2BK28	2.95	2.20	2.60	1	X	X	X	X	X	X	-	-	-	1.75	1.97	0.47	0.25	2.14
2BK30	3.15	2.40	2.80	1	X	X	X	X	X	X	-	-	-	1.75	1.97	0.47	0.25	2.4
2BK32	3.35	2.60	3.00	1	-	X	-	X	X	X	-	-	-	1.75	1.97	0.47	0.25	2.62
2BK34	3.55	2.80	3.20	1	-	X	X	X	X	X	-	-	-	1.75	1.97	0.47	0.25	2.92
2BK36	3.75	3.00	3.40	1	-	-	X	X	X	X	-	X	-	1.75	1.97	0.47	0.25	3.42
2BK40	3.95	3.20	3.60	2	-	X	X	X	X	X	-	-	-	1.75	1.47	0.47	0.75	3.36
2BK45	4.25	3.50	3.90	2	-	-	-	-	X	X	-	X	-	1.75	1.47	0.47	0.75	3.65
2BK47	4.45	3.70	4.10	2	-	-	-	X	X	X	-	X	-	1.75	1.47	0.47	0.75	3.86
2BK50	4.75	4.00	4.40	2	-	-	X	-	X	X	-	X	-	1.75	1.47	0.47	0.75	4.42
2BK52	4.95	4.20	4.60	2	-	-	-	X	X	X	-	X	-	1.75	1.47	0.47	0.75	5.59
2BK55	5.25	4.50	4.90	2	-	-	-	-	-	X	-	X	-	1.75	1.47	0.47	0.75	4.74
2BK57	5.45	4.70	5.20	2	-	-	-	-	X	X	-	X	-	1.75	1.47	0.47	0.75	5.14
2BK60	5.75	5.00	5.40	3	-	-	X	X	X	X	-	X	-	1.75	1.47	0.47	0.75	4.9
2BK62	5.95	5.20	5.60	3	-	-	-	-	X	X	-	X	-	1.75	1.47	0.47	0.75	5.5
2BK65	6.25	5.50	5.90	3	-	-	-	-	X	X	-	X	-	1.75	1.47	0.47	0.75	6.69
2BK67	6.45	5.70	6.10	3	-	-	-	-	X	X	-	X	-	1.75	1.46	0.47	0.76	6.35
2BK70	6.75	6.00	6.40	3	-	-	X	-	X	X	X	X	X	1.75	1.59	0.34	0.50	8.42
2BK80	7.75	7.00	7.40	3	-	-	X	-	X	X	X	X	X	1.75	1.59	0.34	0.50	9.31
2BK90	8.75	8.00	8.40	3	-	-	X	-	X	X	X	X	X	1.75	1.59	0.34	0.50	8.62
2BK100	9.75	9.00	9.40	3	-	-	X	-	X	-	X	X	X	1.75	1.59	0.34	0.50	12.56
2BK110	10.75	10.00	10.40	3	-	-	-	-	X	-	X	-	X	1.75	1.59	0.34	0.50	12.84
2BK120	11.75	11.00	11.40	3	-	-	-	-	X	-	X	-	X	1.75	1.75	0.34	0.50	16.8
2BK130	12.75	12.00	12.40	3	-	-	-	-	X	-	X	-	X	1.75	1.59	0.34	0.50	16.04
2BK140	13.75	13.00	13.40	3	-	-	-	-	X	-	X	-	X	1.75	1.59	0.34	0.50	18.37
2BK160	15.75	15.00	15.40	3	-	-	-	-	X	-	X	-	X	1.75	1.59	0.34	0.50	18.69
2BK190	18.75	18.00	18.40	3	-	-	-	-	-	-	X	-	X	1.75	1.59	0.34	0.50	25.5

Table No.2  
Standard Keyseats

Bore Range (in.)	Keyseat (in.)
1/2	None
5/8 to 7/8	3/16 x 3/32
15/16 to 1 3/16	1/4 x 1/8
1 3/8	5/16 x 5/32
1 7/16	3/8 x 3/16

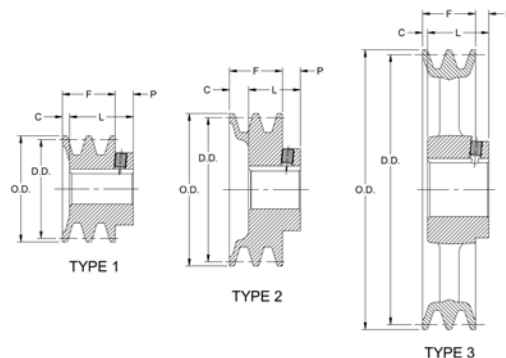

The extensive Browning® V-drive line means maximum economy, versatility and prompt availability for your every application - truly the right drive every time...for every service.

## 2BKH CAST IRON SHEAVES

**Two Groove Sheaves  
Combination Groove**  
for "4L" or "A" Belts and "5L" or "B" Belts

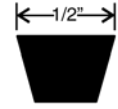

**Table No.1 Stock Sizes with Browning® Split Taper® Bushings**

Part No.	DIAMETER			Type	DIMENSIONS									Wt. Less Bush
	O.D.	Datum "A"	Pitch 3L		O.L.	F	L	P	C	X	G	E		
2BK32H	3.35	2.60	3.00	1	2.78	1.75	1.28	0.88	1.31	0.88	0.44	0.16	2.25	
2BK34H	3.55	2.80	3.20	1	2.78	1.75	1.28	0.88	1.31	0.88	0.44	0.16	2.58	
2BK36H	3.75	3.00	3.40	1	2.78	1.75	1.28	0.88	1.31	0.88	0.44	0.16	2.08	
2BK40H	3.95	3.20	3.60	1	2.78	1.75	1.28	0.88	1.31	0.88	0.44	0.16	2.41	
2BK45H	4.25	3.50	3.90	1	2.78	1.75	1.28	0.88	1.31	0.88	0.44	0.16	3.09	
2BK47H	4.45	3.70	4.10	2	1.75	1.75	1.28	0.44	-	0.88	0.44	0.16	3.04	
2BK50H	4.75	4.00	4.40	2	1.75	1.75	1.28	0.44	-	0.88	0.44	0.16	3.42	
2BK52H	4.95	4.20	4.60	2	1.75	1.75	1.28	0.44	-	0.88	0.44	0.16	3.60	
2BK55H	5.25	4.50	4.90	2	1.75	1.75	1.28	0.44	-	0.88	0.44	0.16	3.84	
2BK57H	5.45	4.70	5.10	2	1.75	1.75	1.28	0.44	-	0.88	0.44	0.16	4.39	
2BK60H	5.75	5.00	5.40	2	1.75	1.75	1.28	0.44	-	0.88	0.44	0.16	4.55	
2BK62H	5.95	5.20	5.60	2	1.75	1.75	1.28	0.44	-	0.88	0.44	0.16	5.05	
2BK65H	6.25	5.50	5.90	3	1.75	1.75	1.28	0.19	0.25	0.88	0.44	0.16	4.75	
2BK67H	6.45	5.70	6.10	3	1.75	1.75	1.28	0.19	0.25	0.88	0.44	0.16	4.85	
2BK70H	6.75	6.00	6.40	3	1.75	1.75	1.28	0.19	0.25	0.88	0.44	0.16	5.13	
2BK80H	7.75	7.00	7.40	3	1.75	1.75	1.28	0.19	0.25	0.88	0.44	0.16	6.90	
2BK90H	8.75	8.00	8.40	3	1.75	1.75	1.28	0.19	0.25	0.88	0.44	0.16	7.31	
2BK100H	9.75	9.00	9.40	3	1.75	1.75	1.28	0.19	0.25	0.88	0.44	0.16	9.83	
2BK110H	10.75	10.00	10.40	3	1.75	1.75	1.28	0.19	0.24	0.89	0.44	0.16	11.91	
2BK120H	11.75	11.00	11.40	3	1.75	1.75	1.28	0.19	0.25	0.88	0.44	0.16	13.30	
2BK130H	12.75	12.00	12.40	3	1.75	1.75	1.28	0.19	0.25	0.88	0.44	0.16	15.25	
2BK140H	13.75	13.00	13.40	3	1.75	1.75	1.28	0.19	0.25	0.88	0.44	0.16	16.61	
2BK160H	15.75	15.00	15.40	3	1.75	1.75	1.28	0.19	0.25	0.88	0.44	0.16	19.27	
2BK190H	18.75	18.00	18.40	3	1.75	1.75	1.28	0.20	0.24	0.88	0.44	0.16	23.53	

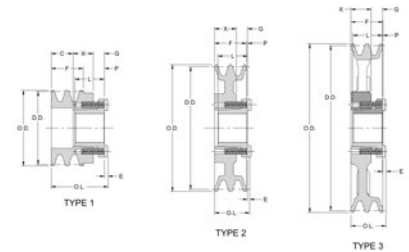

### Browning Split Taper Bushings

- Highest torque carrying capacity in the Browning bushing product line
- Double split barrel assures true concentricity
- Inch, metric and spline bores available from stock

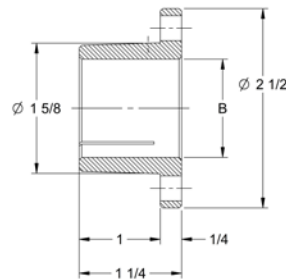

### Combination Groove

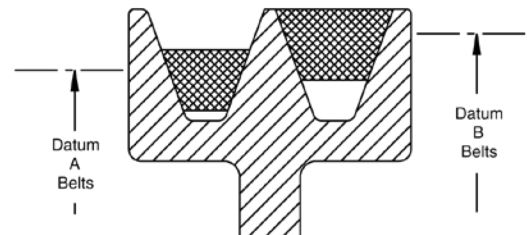

**Table No.2 H bushing**

Bushing	L	U	T	D		H	V	W	X	Y	R	S	Bore Range (in.)		Cap Screws		Avg. Wt. Lbs	Wrench Torque in-lbs	Capscrew Head Projection
				Large End	Small End								Type 1	Type 2	No.	Size			
H	1 1/4	1/4	1	1.625	1.571	2 1/2	2	-	14/16	3/16	1/8	3/16	3/8 - 1 1/8	1 7/16 - 1 1/2	2	1/4-20 x 5/8	0.8	95	0.16

For additional product information, visit [www.regalrexnord.com/Browning](http://www.regalrexnord.com/Browning)



## PROVEN B5V<sup>®</sup> TECHNOLOGY

*Offers the greatest value in the belt drive industry*

**\*Available 1 Through 6 Grooves, Up to 125 hp**

### Same sheave accommodates A, B & 5V Belts!

- Simplifies selection
- Reduces inventories
- 5V performance - B groove economy

### Created through CAD and Finite Element Analysis resulting in:

- Lighter weight
- Higher Strength
- Better Balance than traditional "old style" multiple sheaves

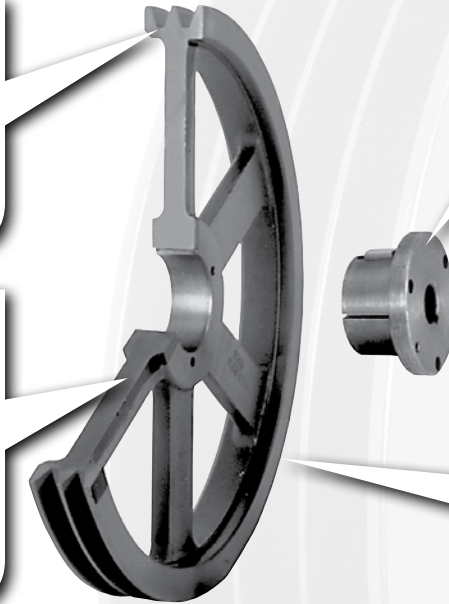

### Utilizes the popular Split Taper design

- Bore range - 1/2" - 3 3/4"
- Shorter barrell length than other competitors, uses less shaft space
- Used extensively throughout line

### Increased capacity

- Expanded offering
- Now through 125 hp
- 1 through 6 groove
- Accommodates 1/2" - 3 3/4" shafts

The B5V line packs into just 180 components what previously comprised some 700 different items of various types and configurations. And it does it without sacrificing flexibility, capacity or economy. In fact, the B5V design directly addresses and solves many of the challenges that have faced buyers and specifiers since V-drives were invented.

### This breakthrough in V-drive technology means you can...

- Experience fewer false starts in drive selection
- Reduce the need to oversize a drive to meet shaft capacity
- Substantially reduce component inventories
- Get more horsepower for your V-drive dollar

### Single groove 5V sheaves – never before available

Because the B5V line offers a full range of sizes 1 through 6 grooves, for the first time you can select the higher capacity of 5V drives in a single groove sheave. This greatly expands 5V application possibilities and further enhances cost savings potential.

### Mix and match with present drive components

Using the new B5V sheave does not make present V-drive components obsolete. In fact, a B5V sheave may be used at any time as the driver or the driven sheave in the same drive with a traditional A/B or B5V sheave, and of course use the same belts. Because B and 5V sheaves utilize different groove spacing, B5V sheaves are not designed for use with banded belts.

## B5V® GRIPBELT® SHEAVES WITH BROWNING® SPLIT TAPER® BUSHINGS

**Table No.1 Specifications - Stock B5V Sheaves**

DIAMETERS				Part Number		Dimensions (in.)	Wt. (Lbs.) Less Bush.
Datum "A" Belts	Datum "B" Belts	Pitch "5V" Belts	Outside	Sheave	Bushing	OL	
<b>1 Groove, Face Width = 1"</b>							
3.8	4.2	4.3	4.48	<b>1B5V42</b>	<b>P1</b>	2 3/16	2.5
4.0	4.4	4.5	4.68	<b>1B5V44</b>	<b>P1</b>	2 3/16	2.8
4.2	4.6	4.7	4.88	<b>1B5V46</b>	<b>B</b>	2 3/16	2.5
4.4	4.8	4.9	5.08	<b>1B5V48</b>	<b>B</b>	2 3/16	2.9
4.6	5.0	5.1	5.28	<b>1B5V50</b>	<b>B</b>	2 3/16	3.3
4.8	5.2	5.3	5.48	<b>1B5V52</b>	<b>B</b>	2 3/16	3.7
5.0	5.4	5.5	5.68	<b>1B5V54</b>	<b>B</b>	2 3/16	4.1
5.2	5.6	5.7	5.88	<b>1B5V56</b>	<b>B</b>	2 3/16	4.5
5.4	5.8	5.9	6.08	<b>1B5V58</b>	<b>B</b>	2 3/16	5.0
5.6	6.0	6.1	6.28	<b>1B5V60</b>	<b>B</b>	2 3/16	5.4
5.8	6.2	6.3	6.48	<b>1B5V62</b>	<b>B</b>	2 3/16	5.3
6.0	6.4	6.5	6.48	<b>1B5V64</b>	<b>B</b>	2 3/16	5.6
6.2	6.6	6.7	6.88	<b>1B5V66</b>	<b>B</b>	2 3/16	6.0
6.4	6.8	6.9	7.08	<b>1B5V68</b>	<b>B</b>	2 3/16	6.4
6.6	7.0	7.1	7.28	<b>1B5V70</b>	<b>B</b>	2 3/16	6.8
7.0	7.4	7.5	7.68	<b>1B5V74</b>	<b>B</b>	2 3/16	7.7
7.6	8.0	8.1	8.28	<b>1B5V80</b>	<b>B</b>	2 5/16	7.5
8.2	8.6	8.7	8.88	<b>1B5V86</b>	<b>B</b>	2 5/16	7.9
8.6	9.0	9.1	9.28	<b>1B5V90</b>	<b>B</b>	2 5/16	8.2
9.0	9.4	9.5	9.68	<b>1B5V94</b>	<b>B</b>	2 5/16	8.5
10.6	11.0	11.1	11.28	<b>1B5V110</b>	<b>B</b>	2 5/16	10.3
12.0	12.4	12.5	12.68	<b>1B5V124</b>	<b>B</b>	2 5/16	11.5
13.2	13.6	13.7	13.88	<b>1B5V136</b>	<b>B</b>	2 5/16	13.3
15.0	15.4	15.5	15.68	<b>1B5V154</b>	<b>B</b>	2 5/16	15.5
15.6	16.0	16.1	16.28	<b>1B5V160</b>	<b>B</b>	2 5/16	16.6
18.0	18.4	18.5	18.68	<b>1B5V184</b>	<b>B</b>	2 5/16	20.0
19.5	20.0	20.1	20.28	<b>1B5V200</b>	<b>B</b>	2 5/16	21.8
22.9	23.4	23.5	23.68	<b>1B5V234</b>	<b>B</b>	2 5/16	28.2
24.5	25.0	25.1	25.28	<b>1B5V250</b>	<b>B</b>	2 5/16	31.4
27.3	27.8	27.9	28.08	<b>1B5V278</b>	<b>B</b>	2 5/16	36.5



- 5V Performance - B Groove Economy
- Combination groove will accept:
  - 4L - A - AX Belts
  - 5L - B - BX Belts
  - 5V - 5VX Belts
- 40% more hp per dollar of cost than traditional 5V sheaves (40% cost reduction)
- Reduced need for duplicate inventory of B and 5V Sheaves

**2 Grooves, Face Width = 1 23/32**

3.8	4.2	4.3	4.48	<b>2B5V42</b>	<b>P1</b>	2 9/32	3.7
4.0	4.4	4.5	4.68	<b>2B5V44</b>	<b>P1</b>	2 3/16	4.1
4.2	4.6	4.7	4.88	<b>2B5V46</b>	<b>B</b>	2 31/64	3.3
4.4	4.8	4.9	5.08	<b>2B5V48</b>	<b>B</b>	2 31/64	3.9
4.6	5.0	5.1	5.28	<b>2B5V50</b>	<b>B</b>	2 31/64	4.6
4.8	5.2	5.3	5.48	<b>2B5V52</b>	<b>B</b>	2 31/64	5.3
5.0	5.4	5.5	5.68	<b>2B5V54</b>	<b>B</b>	2 31/64	6.0
5.2	5.6	5.7	5.88	<b>2B5V56</b>	<b>B</b>	2 31/64	6.7
5.4	5.8	5.9	6.08	<b>2B5V58</b>	<b>B</b>	2 31/64	7.4
5.6	6.0	6.1	6.28	<b>2B5V60</b>	<b>B</b>	2 31/64	8.2
5.8	6.2	6.3	6.48	<b>2B5V62</b>	<b>B</b>	2 31/64	9.2
6.0	6.4	6.5	6.48	<b>2B5V64</b>	<b>B</b>	2 31/64	8.4
6.2	6.6	6.7	6.88	<b>2B5V66</b>	<b>B</b>	2 31/64	11.4

**Table No.2 Bushing Specifications**

Part No.	Bore Range (in.)		Wt. (Lbs.)
	Type 1	Type 2	
<b>P1</b>	1/2 - 1 7/16	1 1/2 - 1 3/4	1.3
<b>B</b>	1/2 - 1 15/16	2 - 2 7/16	1.8

**Browning Split Taper Bushings**

- Keyed to shaft and hub. External key provides positive drive with no torque on the cap screws
- Highest torque carrying capacity in the Browning bushing product line
- Double split barrel assures true concentricity
- Inch, metric and spline bores available from stock

## B5V® GRIPBELT® SHEAVES WITH BROWNING® SPLIT TAPER® BUSHINGS

DIAMETERS				Part Number		Dimensions (in.)	Wt. (Lbs.) Less Bush.
Datum "A" Belts	Datum "B" Belts	Pitch "5V" Belts	Outside	Sheave	Bushing	OL	
<b>2 Grooves (Cont.), Face Width = 1 23/32"</b>							
6.4	6.8	6.9	7.08	2B5V68	B	2 31/64	10.2
6.6	7.0	7.1	7.28	2B5V70	B	2 31/64	12.3
7.0	7.4	7.5	7.68	2B5V74	B	2 31/64	14.2
7.6	8.0	8.1	8.28	2B5V80	B	2 31/64	11.3
8.2	8.6	8.7	8.88	2B5V86	B	2 31/64	10.6
8.6	9.0	9.1	9.28	2B5V90	B	2 31/64	11.1
9.0	9.4	9.5	9.68	2B5V94	B	2 31/64	11.6
10.6	11.0	11.1	11.28	2B5V110	B	2 31/64	14.4
12.0	12.4	12.5	12.68	2B5V124	B	2 31/64	17.1
13.2	13.6	13.7	13.88	2B5V136	B	2 31/64	19.3
15.0	15.4	15.5	15.68	2B5V154	B	2 31/64	23.2
15.6	16.0	16.1	16.28	2B5V160	B	2 31/64	24.2
18.0	18.4	18.5	18.68	2B5V184	B	2 31/64	33.2
19.5	20.0	20.1	20.28	2B5V200	B	2 31/64	34.8
22.9	23.4	23.5	23.68	2B5V234	B	2 31/64	37.9
24.5	25.0	25.1	25.28	2B5V250	B	2 31/64	47.0
27.3	27.8	27.9	28.08	2B5V278	B	2 31/64	55.9
<b>3 Grooves, Face Width = 2 7/16"</b>							
3.8	4.2	4.3	4.48	3B5V42	P1	3 5/16	4.8
4.0	4.4	4.5	4.68	3B5V44	P1	2 23/32	5.2
4.2	4.6	4.7	4.88	3B5V46	B	3 7/16	4.9
4.4	4.8	4.9	5.08	3B5V48	B	3 7/16	5.5
4.6	5.0	5.1	5.28	3B5V50	B	3 7/16	6.1
4.8	5.2	5.3	5.48	3B5V52	B	3 7/16	6.7
5.0	5.4	5.5	5.68	3B5V54	B	2 27/32	7.4
5.2	5.6	5.7	5.88	3B5V56	B	2 27/32	8.4
5.4	5.8	5.9	6.08	3B5V58	B	2 27/32	9.5
5.6	6.0	6.1	6.28	3B5V60	B	2 27/32	10.6
5.8	6.2	6.3	6.48	3B5V62	B	2 27/32	9.8
6.0	6.4	6.5	6.68	3B5V64	B	2 27/32	10.5
6.2	6.6	6.7	6.88	3B5V66	B	2 27/32	10.4
6.4	6.8	6.9	7.08	3B5V68	B	2 27/32	10.9
6.6	7.0	7.1	7.28	3B5V70	B	2 27/32	11.5
7.0	7.4	7.5	7.68	3B5V74	B	2 27/32	12.6
7.6	8.0	8.1	8.28	3B5V80	B	2 27/32	14.2
8.2	8.6	8.7	8.88	3B5V86	B	2 27/32	13.7
8.6	9.0	9.1	9.28	3B5V90	B	2 27/32	14.5
9.0	9.4	9.5	9.68	3B5V94	B	2 27/32	17.0
10.6	11.0	11.1	11.28	3B5V110	B	2 27/32	19.8
12.0	12.4	12.5	12.68	3B5V124	B	2 27/32	22.1
13.2	13.6	13.7	13.88	3B5V136	B	2 27/32	24.9
15.0	15.4	15.5	15.68	3B5V154	B	2 27/32	30.4
15.6	16.0	16.1	16.28	3B5V160	B	2 27/32	31.7
18.0	18.4	18.5	18.68	3B5V184	B	2 27/32	40.9
19.5	20.0	20.1	20.28	3B5V200	B	2 27/32	47.6
22.9	23.4	23.5	23.68	3B5V234	B	2 27/32	61.5
24.5	25.0	25.1	25.28	3B5V250	B	2 27/32	66.6
27.3	27.8	27.9	28.08	3B5V278	B	2 27/32	79.1
<b>4 Grooves, Face Width = 3 5/32"</b>							
3.8	4.2	4.3	4.48	4B5V42	P1	4 1/32	5.9
4.0	4.4	4.5	4.68	4B5V44	P1	3 29/64	6.3
4.2	4.6	4.7	4.88	4B5V46	B	4 5/32	6.1
4.4	4.8	4.9	5.08	4B5V48	B	4 5/32	6.7
4.6	5.0	5.1	5.28	4B5V50	B	4 5/32	7.4
4.8	5.2	5.3	5.48	4B5V52	B	4 5/32	8.0
5.0	5.4	5.5	5.68	4B5V54	B	3 13/64	8.9
5.2	5.6	5.7	5.88	4B5V56	B	3 13/64	9.5
5.4	5.8	5.9	6.08	4B5V58	B	3 13/64	10.3
5.6	6.0	6.1	6.28	4B5V60	B	3 13/64	11.0
5.8	6.2	6.3	6.48	4B5V62	B	3 13/64	11.3
6.0	6.4	6.5	6.68	4B5V64	B	3 13/64	12.1
6.2	6.6	6.7	6.88	4B5V66	B	3 13/64	12.0
6.4	6.8	6.9	7.08	4B5V68	B	3 13/64	12.6
6.6	7.0	7.1	7.28	4B5V70	B	3 13/64	13.2
7.0	7.4	7.5	7.68	4B5V74	B	3 13/64	14.5
7.6	8.0	8.1	8.28	4B5V80	B	3 13/64	15.2
8.2	8.6	8.7	8.88	4B5V86	B	3 13/64	16.6
8.6	9.0	9.1	9.28	4B5V90	B	3 13/64	17.6
9.0	9.4	9.5	9.68	4B5V94	B	3 13/64	20.0
10.6	11.0	11.1	11.28	4B5V110	B	3 13/64	22.8
12.0	12.4	12.5	12.68	4B5V124	B	3 13/64	26.5
13.2	13.6	13.7	13.88	4B5V136	B	3 13/64	30.7
15.0	15.4	15.5	15.68	4B5V154	B	3 13/64	37.9
15.6	16.0	16.1	16.28	4B5V160	B	3 13/64	40.5
18.0	18.4	18.5	18.68	4B5V184	B	3 13/64	50.7
19.5	20.0	20.1	20.28	4B5V200	B	3 13/64	58.5
22.9	23.4	23.5	23.68	4B5V234	B	3 13/64	73.9
24.5	25.0	25.1	25.28	4B5V250	B	3 13/64	83.8
27.3	27.8	27.9	28.08	4B5V278	B	3 13/64	94.3



**Browning B5V Sheaves...**  
**The most significant advance in belt drives since the V-groove!**  
**The introduction of the revolutionary Browning B5V line brings up-to-the minute technology to drive design, operation and inventory control. Now - more than ever - when you specify Browning, you select from one of the most extensive V-belt drive lines in the world.**

- **Combination groove B5V Sheaves - with 170 plus components covering 10-125 hp range. Mix and match with conventional A, B and 5V components.**

**B5V sheaves serve 90% of all 10-125 hp applications!**

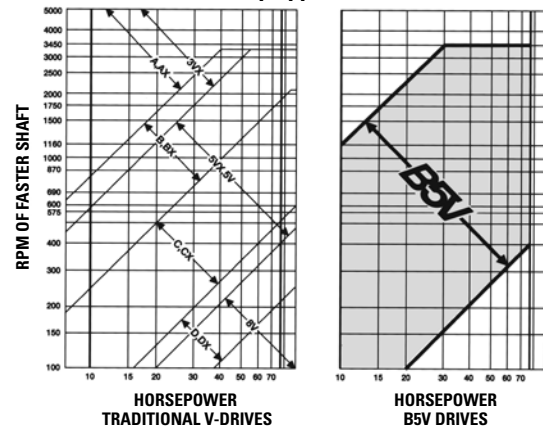

## B5V® GRIPBELT® SHEAVES WITH BROWNING® SPLIT TAPER® BUSHINGS

**Table No.1 Specifications - Stock "B5V" Sheaves**

DIAMETERS				Part Number		Dimensions (in.)	Wt. (Lbs.) Less Bush.
Datum "A" Belts	Datum "B" Belts	Pitch "5V" Belts	Outside	Sheave	Bushing	OL	
<b>5 Grooves, Face Width = 3 7/8"</b>							
3.8	4.2	4.3	4.48	5B5V42	P2	4 3/4	7.83
4.0	4.4	4.5	4.68	5B5V44	P2	4 3/4	8.73
4.2	4.6	4.7	4.88	5B5V46	P2	4 3/4	9.46
4.4	4.8	4.9	5.08	5B5V48	P2	4 3/4	10.31
4.6	5.0	5.1	5.28	5B5V50	Q1	4 29/32	9.63
4.8	5.2	5.3	5.48	5B5V52	Q1	4 29/32	10.79
5.0	5.4	5.5	5.68	5B5V54	Q1	4 29/32	11.98
5.2	5.6	5.7	5.88	5B5V56	Q1	4 9/32	10.41
5.4	5.8	5.9	6.08	5B5V58	Q1	4 9/32	12.35
5.6	6.0	6.1	6.28	5B5V60	Q1	4 9/32	13.86
5.8	6.2	6.3	6.48	5B5V62	Q1	4 9/32	14.94
6.0	6.4	6.5	6.48	5B5V64	Q1	4 9/32	16.78
6.2	6.6	6.7	6.88	5B5V66	Q1	4 9/32	17.19
6.4	6.8	6.9	7.08	5B5V68	Q1	4 9/32	18.09
6.6	7.0	7.1	7.28	5B5V70	Q1	4 1/4	21.05
7.0	7.4	7.5	7.68	5B5V74	Q1	4 1/4	20.95
7.6	8.0	8.1	8.28	5B5V80	R1	4 5/32	28.44
8.2	8.6	8.7	8.88	5B5V86	R1	4 5/32	26.89
8.6	9.0	9.1	9.28	5B5V90	R1	4 5/32	87.84
9.0	9.4	9.5	9.68	5B5V94	R1	4 5/32	28.61
10.6	11.0	11.1	11.28	5B5V110	R1	4 3/32	42.31
12.0	12.4	12.5	12.68	5B5V124	R1	4 3/32	52.15
13.2	13.6	13.7	13.88	5B5V136	R1	4 3/32	45.12
15.0	15.4	15.5	15.68	5B5V154	R1	4 3/32	55.98
15.6	16.0	16.1	16.28	5B5V160	R1	4 3/32	60.19
18.0	18.4	18.5	18.68	5B5V184	R1	4 3/32	77.25
19.5	20.0	20.1	20.28	5B5V200	R1	4 3/32	91.21
24.5	25.0	25.1	25.28	5B5V250	R1	4 3/32	130.19



- 5V Performance - B Groove Economy
- Combination groove will accept:
  - 4L - A - AX Belts
  - 5L - B - BX Belts
  - 5V - 5VX Belts
- 40% more hp per dollar of cost than traditional 5V sheaves (40% cost reduction)
- Reduced need for duplicate inventory of B and 5V Sheaves to support traditional multiple sheave v-belt drive needs.

**6 Grooves, Face Width = 4 19/32"**

3.8	4.2	4.3	4.48	6B5V42	P2	5 15/32	8.97
4.0	4.4	4.5	4.68	6B5V44	P2	5 15/32	9.93
4.2	4.6	4.7	4.88	6B5V46	P2	5 15/32	10.64
4.4	4.8	4.9	5.08	6B5V48	P2	5 15/32	11.53
4.6	5.0	5.1	5.28	6B5V50	Q2	5 5/8	10.91
4.8	5.2	5.3	5.48	6B5V52	Q2	5 5/8	12.13
5.0	5.4	5.5	5.68	6B5V54	Q2	5 5/8	13.39
5.2	5.6	5.7	5.88	6B5V56	Q2	5 5/8	12.86
5.4	5.8	5.9	6.08	6B5V58	Q1	5 5/8	13.65
5.6	6.0	6.1	6.28	6B5V60	Q1	5 5/8	14.86
5.8	6.2	6.3	6.48	6B5V62	Q1	5 5/8	16.51
6.0	6.4	6.5	6.68	6B5V64	Q1	5 5/8	17.38
6.2	6.6	6.7	6.88	6B5V66	Q1	5 5/8	18.52
6.4	6.8	6.9	7.08	6B5V68	Q1	5 5/8	20.14
6.6	7.0	7.1	7.28	6B5V70	Q2	4 39/64	23.01
7.0	7.4	7.5	7.68	6B5V74	Q2	4 39/64	22.93
7.6	8.0	8.1	8.28	6B5V80	R1	4 19/32	32.55
8.2	8.6	8.7	8.88	6B5V86	R1	4 19/32	29.63
8.6	9.0	9.1	9.28	6B5V90	R1	4 19/32	30.67
9.0	9.4	9.5	9.68	6B5V94	R1	4 19/32	31.35
10.6	11.0	11.1	11.28	6B5V110	R1	4 19/32	45.69
12.0	12.4	12.5	12.68	6B5V124	R1	4 19/32	52.23
13.2	13.6	13.7	13.88	6B5V136	R1	4 19/32	48.81
15.0	15.4	15.5	15.68	6B5V154	R1	4 19/32	60.36
15.6	16.0	16.1	16.28	6B5V160	R1	4 19/32	63.72
18.0	18.4	18.5	18.68	6B5V184	R1	4 19/32	82.89
19.5	20.0	20.1	20.28	6B5V200	R1	4 19/32	100.23
24.5	25.0	25.1	25.28	6B5V250	R1	4 19/32	140.18

Mix and match with present drive components.

Using the B5V sheave does not make present V-drive components obsolete. In fact, a B5V sheave may be used at any time as the driver or the driven sheave in the same drive with a traditional A/B or 5V sheave, and of course use the same belts.

Note: Because B and 5V sheaves utilize different groove spacing, B5V sheaves are not designed for use with banded belts.

## TB GRIPBELT® SHEAVES WITH BROWNING® SPLIT TAPER® BUSHINGS

For Use with All "A" and "B" Section Belts

**Table No.1 Specifications - Stock "TB" Sheaves**

DIAMETERS (in.)				1 Groove, Face Width = 1"			
Datum "A"	Datum "B"	Outside	Inside	Part Number		Dimensions (in.)	Wt. Less Bush.
				Sheave	Bushing	OL	
3.0	3.4	3.75	-	1TB34	P1	2 5/16	2.0
3.2	3.6	3.95	-	1TB36	P1	2 5/16	2.3
3.4	3.8	4.15	-	1TB38	P1	2 5/16	2.6
3.6	4.0	4.35	-	1TB40	P1	2 3/16	2.1
3.8	4.2	4.55	-	1TB42	P1	2 3/16	2.4
4.0	4.4	4.75	-	1TB44	P1	2 3/16	2.8
4.2	4.6	4.95	-	1TB46	P1	2 3/16	3.1
4.4	4.8	5.15	-	1TB48	P1	2 3/16	3.5
4.6	5.0	5.35	-	1TB50	P1	2 3/16	3.9
4.8	5.2	5.55	-	1TB52	P1	2 3/16	4.1
5.0	5.4	5.75	-	1TB54	P1	2 3/16	4.6
5.2	5.6	5.95	-	1TB56	P1	2 3/16	5.1
5.4	5.8	6.15	-	1TB58	P1	2 3/16	5.6
5.6	6.0	6.35	4 1/2	1TB60	P1	2 3/16	6.0
5.8	6.2	6.55	4 11/16	1TB62	P1	2 3/16	5.5
6.0	6.4	6.75	4 7/8	1TB64	P1	2 3/16	5.8
6.2	6.6	6.95	5 1/16	1TB66	P1	2 3/16	5.9
6.4	6.8	7.15	5 5/16	1TB68	P1	2 3/16	6.1
6.6	7.0	7.35	5 1/2	1TB70	P1	2 3/16	6.4
7.0	7.4	7.75	5 15/16	1TB74	P1	2 3/16	7.3
7.6	8.10	8.35	6 1/2	1TB80	P1	2 3/16	7.8
8.2	8.6	8.95	7 1/16	1TB86	P1	2 3/16	8.6
8.6	9.0	9.35	7 1/2	1TB90	P1	2 3/16	8.9
9.0	9.4	9.75	7 15/16	1TB94	P1	2 3/16	9.1
10.6	11.0	11.35	9 7/16	1TB110	P1	2 3/16	11.1
12.0	12.4	12.75	10 15/16	1TB124	Q1	2 25/32	17.8
13.2	13.6	13.95	12 1/16	1TB136	Q1	2 25/32	18.2
15.0	15.4	15.75	13 15/16	1TB154	Q1	2 25/32	20.3
15.6	16.0	16.35	14 1/2	1TB160	Q1	2 25/32	22.0
18.0	18.4	18.75	16 15/16	1TB184	Q1	2 25/32	27.5
19.5	20.0	20.35	18 1/2	1TB200	Q1	2 25/32	27.2
24.5	25.0	25.35	23 1/2	1TB250	Q1	2 25/32	42.4
29.5	30.0	30.35	28 1/2	1TB300	Q1	2 25/32	56.0
37.5	38.0	38.35	36 1/2	1TB380	Q1	2 25/32	78.0

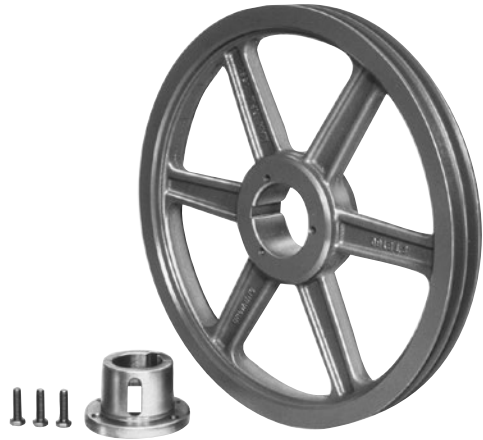
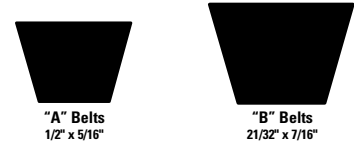

- 1 - 6 grooves
- 3.75" - 38.35" O.D.
- 1/2" - 2 11/16" bore range
- Machined from fine grain cast iron
- Precision balanced
- Easy on - easy off

**Table No.2 Standard Keyseats**

Bore Range (in.)	Keyseat (in.)
1/2 - 9/16	1/8 x 1/16
5/8 - 7/8	3/16 x 3/32
15/16 - 1 1/4	1/4 x 1/8
15/16 - 1 3/8	5/16 x 5/32
1 7/16 - 1 3/4	3/8 x 3/16
1 13/16 - 2 1/4	1/2 x 1/4
2 5/16 - 2 11/16	5/8 x 5/16

1 3/8" bore bushings also available with 3/8" x 3/16" keyseat.

**Table No.3 Bushing Dimensions**

Part No.	Bore Range (in.)	Wt. Lbs.
P1	1/2 - 1 3/4	1 1/4
P2	3/4 - 1 3/4	1 1/2
Q1	3/4 - 2 11/16	3 1/2

### Browning Split Taper Bushings

- Keyed to shaft and hub. External key provides positive drive with no torque on the cap screws
- Highest torque carrying capacity in the Browning bushing product line
- Double split barrel assures true concentricity
- Inch, metric and spline bores available from stock

## TB GRIPBELT® SHEAVES WITH BROWNING® SPLIT TAPER® BUSHINGS

For Use with All "A" and "B" Section Belts

**Table No.1 Specifications - Stock "TB" Sheaves**

DIAMETERS (in.)				2 Grooves, Face Width = 1 3/4"			
Datum "A"	Datum "B"	Outside	Inside	Part Number		Dimensions (in.)	Wt. Less Bush.
				Sheave	Bushing	OL	
3.0	3.4	3.75	-	2TB34	P1	3 1/16	2.9
3.2	3.6	3.95	-	2TB36	P1	3 1/16	3.8
3.4	3.8	4.15	1 5/16	2TB38	P1	2 5/8	3.0
3.6	4.0	4.35	2 1/2	2TB40	P1	2 5/8	3.8
3.8	4.2	4.55	2 11/16	2TB42	P1	2 5/8	3.9
4.0	4.4	4.75	2 7/8	2TB44	P1	2 3/16	3.9
4.2	4.6	4.95	3 1/16	2TB46	P1	2 3/16	4.5
4.4	4.8	5.15	3 5/16	2TB48	P1	2 3/16	5.3
4.6	5.0	5.35	3 1/2	2TB50	P1	2 3/16	5.6
4.8	5.2	5.55	3 11/16	2TB52	P1	2 3/16	6.1
5.0	5.4	5.75	3 7/8	2TB54	P1	2 3/16	6.5
5.2	5.6	5.95	4 1/16	2TB56	P1	2 3/16	7.4
5.4	5.8	6.15	4 5/16	2TB58	P1	2 3/16	8.0
5.6	6.0	6.35	4 1/2	2TB60	P1	2 3/16	8.9
5.8	6.2	6.55	4 11/16	2TB62	P1	2 3/16	7.6
6.0	6.4	6.75	4 7/8	2TB64	P1	2 3/16	7.8
6.2	6.6	6.95	5 1/16	2TB66	P1	2 3/16	8.3
6.4	6.8	7.15	5 5/16	2TB68	P1	2 3/16	8.8
6.6	7.0	7.35	5 1/2	2TB70	Q1	2 25/32	11.1
7.0	7.4	7.75	5 15/16	2TB74	Q1	2 25/32	11.5
7.6	8.0	8.35	6 1/2	2TB80	Q1	2 25/32	12.8
8.2	8.6	8.95	7 1/16	2TB86	Q1	2 25/32	16.0
8.6	9.0	9.35	7 1/2	2TB90	Q1	2 25/32	15.1
9.0	9.4	9.75	7 15/16	2TB94	Q1	2 25/32	15.5
10.6	11.0	11.35	9 7/16	2TB110	Q1	2 25/32	18.9
12.0	12.4	12.75	10 15/16	2TB124	Q1	2 25/32	21.1
13.2	13.6	13.95	12 1/16	2TB136	Q1	2 25/32	23.0
15.0	15.4	15.75	13 15/16	2TB154	Q1	2 25/32	24.8
15.6	16.0	16.35	14 1/2	2TB160	Q1	2 25/32	27.0
18.0	18.4	18.75	16 15/16	2TB184	Q1	2 25/32	32.3
19.5	20.0	20.35	18 1/2	2TB200	Q1	2 25/32	42.3
24.5	25.0	25.35	23 1/2	2TB250	Q1	2 25/32	50.3
29.5	30.0	30.35	28 1/2	2TB300	Q1	2 25/32	68.8
37.5	38.0	38.35	35 1/2	2TB380	Q1	2 25/32	95.5

For optimum sheave selection, see B5V® Stock Sheave Listing on pages 19-23.

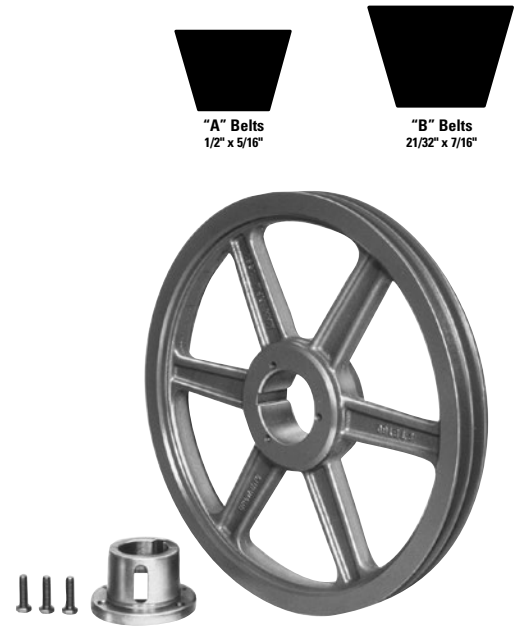

- 1 - 6 grooves
- 3.75" - 38.35" O.D.
- 1/2" - 2 11/16" bore range
- Machined from fine grain cast iron
- Precision balanced
- Easy on - easy off

**Table No.2**

DIAMETERS (in.)				3 Grooves, Face Width = 2 1/2"			
Datum "A"	Datum "B"	Outside	Inside	Part Number		Dimensions (in.)	Wt. Less Bush.
				Sheave	Bushing	OL	
3.0	3.4	3.75	2	3TB34	P2	3 13/16	3.8
3.2	3.6	3.95	2 1/16	3TB36	P2	3 13/16	4.4
3.4	3.8	4.15	2 5/16	3TB38	P1	3 3/8	3.8
3.6	4.0	4.35	2 1/2	3TB40	P1	3 3/8	4.5
3.8	4.2	4.55	2 11/16	3TB42	P1	3 3/8	4.9
4.0	4.4	4.75	2 7/8	3TB44	P1	2 3/4	5.1
4.2	4.6	4.95	3 1/16	3TB46	P1	2 3/4	6.0
4.4	4.8	5.15	3 5/16	3TB48	P1	2 3/4	6.3
4.6	5.0	5.35	3 1/2	3TB50	P1	2 3/4	6.9
4.8	5.2	5.55	3 11/16	3TB52	P1	2 3/4	7.5
5.0	5.4	5.75	3 7/8	3TB54	P1	2 3/4	8.3
5.2	5.6	5.95	4 1/16	3TB56	P1	2 3/4	9.0
5.4	5.8	6.15	4 5/16	3TB58	P1	2 3/4	9.6
5.6	6.0	6.35	4 1/2	3TB60	P1	2 3/4	10.5
5.8	6.2	6.55	4 11/16	3TB62	P1	2 3/4	9.4
6.0	6.4	6.75	4 7/8	3TB64	P1	2 3/4	9.5
6.2	6.6	6.95	5 1/16	3TB66	P1	2 3/4	10.0
6.4	6.8	7.15	5 5/16	3TB68	P1	2 3/4	10.4
6.6	7.0	7.35	5 1/2	3TB70	Q1	3 5/32	13.0
7.0	7.4	7.75	5 15/16	3TB74	Q1	3 5/32	13.3
7.6	8.0	8.35	6 1/2	3TB80	Q1	3 5/32	15.3
8.2	8.6	8.95	7 1/16	3TB86	Q1	3 5/32	18.9
8.6	9.0	9.35	7 1/2	3TB90	Q1	3 5/32	18.1
9.0	9.4	9.75	7 15/16	3TB94	Q1	3 5/32	18.0
10.6	11.0	11.35	9 7/16	3TB110	Q1	3 5/32	21.3
12.0	12.4	12.75	10 15/16	3TB124	Q1	3 5/32	25.4
13.2	13.6	13.95	12 1/16	3TB136	Q1	3 5/32	27.4
15.0	15.4	15.75	13 15/16	3TB154	Q1	3 5/32	29.8
15.6	16.0	16.35	14 1/2	3TB160	Q1	3 5/32	32.0
18.0	18.4	18.75	16 15/16	3TB184	Q1	3 5/32	37.8
19.5	20.0	20.35	18 1/2	3TB200	Q1	3 5/32	49.9
24.5	25.0	25.35	23 1/2	3TB250	Q1	3 5/32	61.0
29.5	30.0	30.35	28 1/2	3TB300	Q1	3 5/32	78.5
37.5	38.0	38.35	36 1/2	3TB380	Q1	3 5/32	110.0

For optimum sheave selection, see B5V Stock Sheave Listing on pages 19-23.

**Table No.3 Bushing Dimensions**

Part No.	Bore Range (in.)	Wt. Lbs.
P1	1/2 - 1 3/4	1 1/4
P2	3/4 - 1 3/4	1 1/2
Q1	3/4 - 2 11/16	3 1/2

**Browning Split Taper Bushings**

- Keyed to shaft and hub. External key provides positive drive with no torque on the cap screws
- Highest torque carrying capacity in the Browning bushing product line
- Double split barrel assures true concentricity
- Inch, metric and spline bores available from stock

## TB GRIPBELT® SHEAVES WITH BROWNING® SPLIT TAPER® BUSHINGS

For Use with All "A" and "B" Section Belts

**Table No.1 Specifications - Stock "TB" Sheaves**

DIAMETERS (in.)				4 Grooves, Face Width = 13/4"			
Datum "A"	Datum "B"	Outside	Inside	Part Number		Dimensions (in.) OL	Wt. Less Bush.
				Sheave	Bushing		
3.0	3.4	3.75	2	4TB34	P2	4 9/16	4.5
3.2	3.6	3.95	2 1/16	4TB36	P2	4 9/16	5.3
3.4	3.8	4.15	2 5/16	4TB38	P1	4 1/8	4.8
3.6	4.0	4.35	2 1/2	4TB40	P1	4 1/8	5.5
3.8	4.2	4.55	2 11/16	4TB42	P1	4 1/8	5.9
4.0	4.4	4.75	2 7/8	4TB44	P1	3 1/2	6.5
4.2	4.6	4.95	3 1/6	4TB46	P1	3 1/2	7.1
4.4	4.8	5.15	3 5/16	4TB48	P1	3 1/2	7.5
4.6	5.0	5.35	3 1/2	4TB50	P1	3 1/2	8.3
4.8	5.2	5.55	3 11/16	4TB52	P1	3 1/2	9.1
5.0	5.4	5.75	3 7/8	4TB54	P1	3 1/2	9.6
5.2	5.6	5.95	4 1/16	4TB56	P1	3 1/2	10.6
5.4	5.8	6.15	4 5/16	4TB58	P1	3 1/2	11.6
5.6	6.0	6.35	4 1/2	4TB60	P1	3 1/2	11.9
5.8	6.2	6.55	4 11/16	4TB62	P1	3 1/2	11.1
6.0	6.4	6.75	4 7/8	4TB64	P1	3 1/2	11.8
6.2	6.6	6.95	5 1/16	4TB66	P1	3 1/2	12.0
6.4	6.8	7.15	5 5/16	4TB68	P1	3 1/2	12.5
6.6	7.0	7.35	5 1/2	4TB70	Q1	3 17/32	15.3
7.0	7.4	7.75	5 15/16	4TB74	Q1	3 17/32	15.3
7.6	8.0	8.35	6 1/2	4TB80	Q1	3 17/32	17.0
8.2	8.6	8.95	7 1/16	4TB86	Q1	3 17/32	20.8
8.6	9.0	9.35	7 1/2	4TB90	Q1	3 17/32	20.6
9.0	9.4	9.75	7 15/16	4TB94	Q1	3 17/32	20.1
10.6	11.0	11.35	9 7/16	4TB110	Q1	3 17/32	25.8
12.0	12.4	12.75	10 15/16	4TB124	Q1	3 17/32	27.5
13.2	13.6	13.95	12 1/16	4TB136	Q1	3 17/32	31.5
15.0	15.4	15.75	13 15/16	4TB154	Q1	3 17/32	36.0
15.6	16.0	16.35	14 1/2	4TB160	Q1	3 17/32	39.0
18.0	18.4	18.75	16 15/16	4TB184	Q1	3 17/32	44.8
19.5	20.0	20.35	18 1/2	4TB200	Q1	3 17/32	57.0
24.5	25.0	25.35	23 1/2	4TB250	Q1	3 17/32	69.5
29.5	30.0	30.35	28 1/2	4TB300	Q1	3 17/32	90.8
37.5	38.0	38.35	36 1/2	4TB380	Q1	3 17/32	125.0

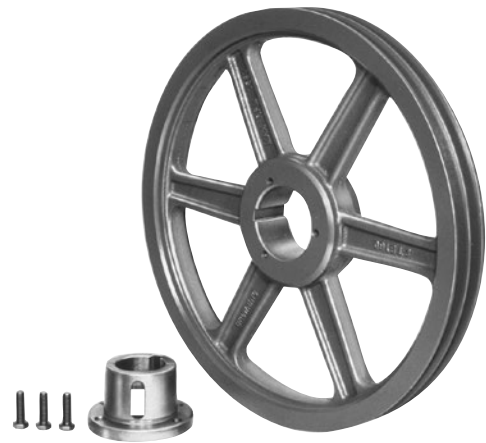
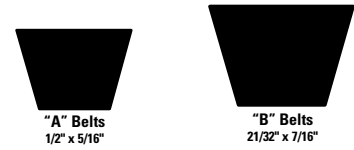

- 1 - 6 grooves
- 3.75" - 38.35" O.D.
- 1/2" - 2 11/16" bore range
- Machined from fine grain cast iron
- Precision balanced
- Easy on - easy off

For optimum sheave selection, see B5V® Stock Sheave Listing on pages 23-35.

**Table No.2 Standard Keyseats**

Bore Range (in.)	Keyseat (in.)
1/2 - 9/16	1/8 x 1/16
5/8 - 7/8	3/16 x 3/32
15/16 - 1 1/4	1/4 x 1/8
15/16 - 1 3/8	5/16 x 5/32
1 7/16 - 1 3/4	3/8 x 3/16
1 13/16 - 2 1/4	1/2 x 1/4
2 5/16 - 2 11/16	5/8 x 5/16

1 3/8" bore bushings also available with 3/8" x 3/16" keyseat.

**Table No.3 Bushing Dimensions**

Part No.	Bore Range (in.)	Wt. Lbs.
P1	1/2 - 1 3/4	1 1/4
P2	3/4 - 1 3/4	1 1/2
Q1	3/4 2 11/16	3 1/2

### Browning Split Taper Bushings

- Keyed to shaft and hub. External key provides positive drive with no torque on the cap screws
- Highest torque carrying capacity in the Browning bushing product line
- Double split barrel assures true concentricity
- Inch, metric and spline bores available from stock

## TB GRIPBELT® SHEAVES WITH BROWNING® SPLIT TAPER® BUSHINGS

For Use with All "A" and "B" Section Belts

**Table No.1 Specifications - Stock "TB" Sheaves**

DIAMETERS (in.)				5 Grooves, Face Width = 4"			
Datum "A"	Datum "B"	Outside	Inside	Part Number		Dimensions (in.)	Wt. Less Bush.
				Sheave	Bushing	OL	
3.0	3.4	3.75	2	5TB34	P2	5 5/16	5.3
3.2	3.6	3.95	2 1/16	5TB36	P2	5 5/16	6.1
3.4	3.8	4.15	1 5/16	5TB38	P2	4 7/8	6.1
3.6	4.0	4.35	2 1/2	5TB40	P2	4 7/8	7.0
3.8	4.2	4.55	2 11/16	5TB42	P2	4 7/8	7.8
4.0	4.4	4.75	2 7/8	5TB44	P2	4 1/4	8.5
4.2	4.6	4.95	3 1/16	5TB46	P2	4 1/4	9.8
4.4	4.8	5.15	3 5/16	5TB48	P2	4 1/4	10.5
4.6	5.0	5.35	3 1/2	5TB50	P2	4 1/4	11.6
4.8	5.2	5.55	3 11/16	5TB52	P2	4 1/4	12.5
5.0	5.4	5.75	3 7/8	5TB54	Q1	4 9/32	10.4
5.2	5.6	5.95	4 1/16	5TB56	Q1	4 9/32	11.8
5.4	5.8	6.15	4 5/16	5TB58	Q1	4 9/32	12.8
5.6	6.0	6.35	4 1/2	5TB60	Q1	4 9/32	13.8
5.8	6.2	6.55	4 11/16	5TB62	Q1	4 9/32	14.8
6.0	6.4	6.75	4 7/8	5TB64	Q1	4 9/32	16.4
6.2	6.6	6.95	5 1/16	5TB66	Q1	4 9/32	17.1
6.4	6.8	7.15	5 5/16	5TB68	Q1	4 9/32	17.9
6.6	7.0	7.35	5 1/2	5TB70	Q2	4 13/32	20.9
7.0	7.4	7.75	5 15/16	5TB74	Q2	4 13/32	19.8
7.6	8.0	8.35	6 1/2	5TB80	Q2	4 13/32	22.3
8.2	8.6	8.95	7 1/16	5TB86	Q2	4 13/32	29.5
8.6	9.0	9.35	7 1/2	5TB90	Q2	4 13/32	28.6
9.0	9.4	9.75	7 15/16	5TB94	Q2	4 13/32	29.5
10.6	11.0	11.35	9 7/16	5TB110	Q2	4 13/32	32.8
12.0	12.4	12.75	10 15/16	5TB124	Q2	4 13/32	35.4
13.2	13.6	13.95	12 1/16	5TB136	Q2	4 13/32	41.0
15.0	15.4	15.75	13 15/16	5TB154	Q2	4 13/32	45.3
15.6	16.0	16.35	14 1/2	5TB160	Q2	4 13/32	48.0
18.0	18.4	18.75	16 15/16	5TB184	Q2	4 13/32	57.3
19.5	20.0	20.35	18 1/2	5TB200	Q2	4 13/32	66.0
24.5	25.0	25.35	23 1/2	5TB250	Q2	4 13/32	82.5
29.5	30.0	30.35	28 1/2	5TB300	Q2	4 13/32	117.0
37.5	38.0	38.35	36 1/2	5TB380	Q2	4 13/32	159.0

For optimum sheave selection, see B5V® Stock Sheave Listing on pages 19-23.

**Table No.2**

DIAMETERS (in.)				6 Grooves, Face Width = 4 3/4"			
Datum "A"	Datum "B"	Outside	Inside	Part Number		Dimensions (in.)	Wt. Less Bush.
				Sheave	Bushing	OL	
3.0	3.4	3.75	2	6TB34	P2	6 1/16	6.1
3.2	3.6	3.95	2 1/16	6TB36	P2	6 1/16	7.3
3.4	3.8	4.15	2 5/16	6TB38	P2	5 5/8	7.0
3.6	4.0	4.35	2 1/2	6TB40	P2	5 5/8	8.1
3.8	4.2	4.55	2 11/16	6TB42	P2	5 5/8	9.3
4.0	4.4	4.75	2 7/8	6TB44	P2	5	9.9
4.2	4.6	4.95	3 1/16	6TB46	P2	5	11.0
4.4	4.8	5.15	3 5/16	6TB48	P2	5	11.8
4.6	5.0	5.35	3 1/2	6TB50	P2	5	12.9
4.8	5.2	5.55	3 11/16	6TB52	P2	5	14.8
5.0	5.4	5.75	3 7/8	6TB54	Q1	5 1/32	11.8
5.2	5.6	5.95	4 1/16	6TB56	Q1	5 1/32	17.3
5.4	5.8	6.15	4 5/16	6TB58	Q1	5 1/32	14.5
5.6	6.0	6.35	4 1/2	6TB60	Q1	5 1/32	15.4
5.8	6.2	6.55	4 11/16	6TB62	Q1	5 1/32	16.4
6.0	6.4	6.75	4 7/8	6TB64	Q1	5 1/32	18.6
6.2	6.6	6.95	5 1/16	6TB66	Q1	5 1/32	18.5
6.4	6.8	7.15	5 5/16	6TB68	Q1	5 1/32	20.8
6.6	7.0	7.35	5 1/2	6TB70	Q2	4 25/32	22.8
7.0	7.4	7.75	5 15/16	6TB74	Q2	4 25/32	26.5
7.6	8.0	8.35	6 1/2	6TB80	Q2	4 25/32	24.1
8.2	8.6	8.95	7 1/16	6TB86	Q2	4 25/32	27.1
8.6	9.0	9.35	7 1/2	6TB90	Q2	4 25/32	30.6
9.0	9.4	9.75	7 15/16	6TB94	Q2	4 25/32	32.8
10.6	11.0	11.35	9 7/16	6TB110	Q2	4 25/32	36.6
12.0	12.4	12.75	10 15/16	6TB124	Q2	4 25/32	39.8
13.2	13.6	13.95	12 1/16	6TB136	Q2	4 25/32	44.9
15.0	15.4	15.75	13 15/16	6TB154	Q2	4 25/32	49.9
15.6	16.0	16.35	14 1/2	6TB160	Q2	4 25/32	54.0
18.0	18.4	18.75	16 15/16	6TB184	Q2	4 25/32	62.0
19.5	20.0	20.35	18 1/2	6TB200	Q2	4 25/32	74.0
24.5	25.0	25.35	23 1/2	6TB250	Q2	4 25/32	89.5
29.5	30.0	30.35	28 1/2	6TB300	Q2	4 25/32	128.0
37.5	38.0	38.35	36 1/2	6TB380	Q2	4 25/32	179.0

For optimum sheave selection, see B5V Stock Sheave Listing on pages 23-35.

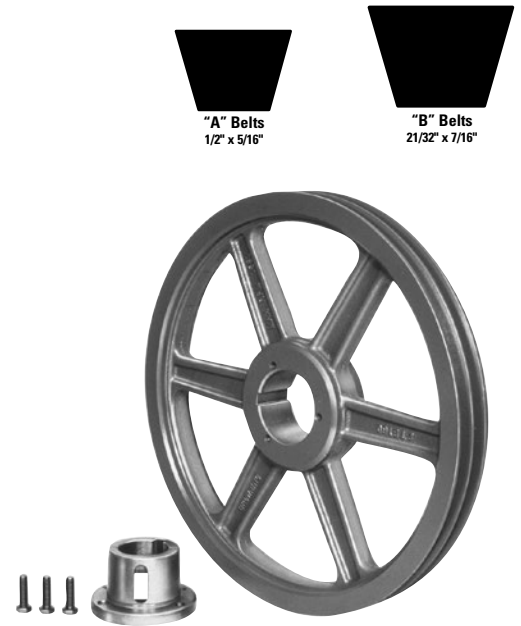

- 1 - 6 grooves
- 3.75" - 38.35" O.D.
- 1/2" - 2 11/16" bore range
- Machined from fine grain cast iron
- Precision balanced
- Easy on - easy off

**Table No.3 Bushing Dimensions**

Part No.	Bore Range (in.)	Wt. Lbs.
P1	1/2 - 1 3/4	1 1/4
P2	3/4 - 1 3/4	1 1/2
Q1	3/4 2 11/16	3 1/2
Q2	1 - 2 5/8	4 1/2

**Browning Split Taper Bushings**

- Keyed to shaft and hub. External key provides positive drive with no torque on the cap screws
- Highest torque carrying capacity in the Browning bushing product line
- Double split barrel assures true concentricity
- Inch, metric and spline bores available from stock

### B GRIPBELT® SHEAVES WITH BROWNING® SPLIT TAPER® BUSHINGS For Use with All "A" and "B" Section Belts

**Table No.1 Specifications - Stock "B" Sheaves**

DIAMETERS (in.)				2 Grooves, Face Width = 1 3/4"			
Datum "A"	Datum "B"	Outside	Inside	Part Number		Dimensions (in.)	Wt. Less Bush.
				Sheave	Bushing	OL	
5.0	5.4	5.75	-	2B54Q	Q1	2 25/32	6.0
5.2	5.6	5.95	-	2B56Q	Q1	2 25/32	7.3
5.4	5.8	6.15	-	2B58Q	Q1	2 25/32	7.9
5.6	6.0	6.35	-	2B60Q	Q1	2 25/32	8.9
5.8	6.2	6.55	-	2B62Q	Q1	2 25/32	9.4
6.0	6.4	6.75	-	2B64Q	Q1	2 25/32	10.1
6.2	6.6	6.95	-	2B66Q	Q1	2 25/32	11.1
6.4	6.8	7.15	-	2B68Q	Q1	2 25/32	12.3
15.0	15.4	15.75	13 7/8	2B154R	R1	3 5/32	30.6
15.6	16.0	16.35	14 1/2	2B160R	R1	3 5/32	32.0
18.0	18.4	18.75	16 7/8	2B184R	R1	3 5/32	39.1
19.5	20.0	20.35	18 1/2	2B200R	R1	3 5/32	43.5
24.5	25.0	25.35	23 1/2	2B250R	R1	3 5/32	58.0
29.5	30.0	30.35	28 1/2	2B300R	R1	3 5/32	81.0
37.5	38.0	38.35	36 1/2	2B380R	R1	3 5/32	92.0

For optimum sheave selection, see B5V® Stock Sheave Listing on pages 23-35.

**Table No.2**

DIAMETERS (in.)				3 Grooves, Face Width = 2 1/2"			
Datum "A"	Datum "B"	Outside	Inside	Part Number		Dimensions (in.)	Wt. Less Bush.
				Sheave	Bushing	OL	
5.0	5.4	5.75"	3 7/8	3B54Q	Q1	3 17/32	7.9
5.2	5.6	5.95	4 1/16	3B56Q	Q1	3 17/32	9.0
5.4	5.8	6.15	4 1/4	3B58Q	Q1	3 5/32	9.4
5.6	6.0	6.35	4 7/16	3B60Q	Q1	3 5/32	10.4
5.8	6.2	6.55	4 11/16	3B62Q	Q1	3 5/32	11.3
6.0	6.4	6.75	4 7/8	3B64Q	Q1	3 5/32	12.1
6.2	6.6	6.95	5 1/16	3B66Q	Q1	3 5/32	13.0
6.4	6.8	7.15	5 1/4	3B68Q	Q1	3 5/32	14.3
15.0	15.4	15.75	13 7/8	3B154R	R1	3 13/32	35.5
15.6	16.0	16.35	14 1/2	3B160R	R1	3 13/32	38.0
18.0	18.4	18.75	16 7/8	3B184R	R1	3 13/32	44.8
19.5	20.0	20.35	18 1/2	3B200R	R1	3 13/32	50.3
24.5	25.0	25.35	23 1/2	3B250R	R1	3 13/32	65.0
29.5	30.0	30.35	28 1/2	3B300R	R1	3 13/32	89.0
37.5	38.0	38.35	36 1/2	3B380R	R1	3 13/32	106

For optimum sheave selection, see B5V® Stock Sheave Listing on pages 23-35.

**Table No.3 Standard Keyseats**

Bore Range (in.)	Keyseat (in.)
3/4-7/8	3/16 X 3/32
15/16-1 1/4	1/4 X 1/8
1 5/16-1 3/8	5/16 X 5/32
1 7/16-1 3/4	3/8 X 3/16
1 13/16-2 1/4	1/2 X 1/4
2 5/16-2 3/4	5/8 X 5/16
2 13/16-3 1/4	3/4 X 3/8
3 3/8-3 3/4	7/8 X 7/16

1 3/8" bore bushings also available with 3/8" x 3/16" keyseat.

**Table No.4 Bushing Dimensions**

Part No.	Bore Range (in.)	Wt. Lbs.
Q1	3/4-2 11/16	3 1/2
R1	1 1/8-3 3/4	7 1/2



- 2 - 8 grooves
- 5.75" - 38.35" O.D.
- 1/2" - 2 5/8" bore range
- Machined from fine grain cast iron
- Precision balanced
- Easy on - easy off

#### Browning Split Taper Bushings

- Keyed to shaft and hub  
External key provides positive drive with no torque on the cap screws
- Highest torque carrying capacity in the Browning bushing product line
- Double split barrel assures true concentricity
- Inch, metric and spline bores available from stock

## B GRIPBELT® SHEAVES WITH BROWNING® SPLIT TAPER® BUSHINGS

For Use with All "A" and "B" Section Belts

**Table No.1 Specifications - Stock "B" Sheaves**

DIAMETERS (in.)				4 Grooves, Face Width = 3 1/4"			
Datum "A"	Datum "B"	Outside	Inside	Part Number		Dimensions (in.)	Wt. Less Bush
				Sheave	Bushing	OL	
5.0	5.4	5.75	3 7/8	4B54Q	Q1	4 9/32	9.3
5.2	5.6	5.95	4 1/16	4B56Q	Q1	4 9/32	10.5
5.4	5.8	6.15	4 1/4	4B58Q	Q1	3 17/32	11.5
5.6	6.0	6.35	4 7/16	4B60Q	Q1	3 17/32	12.6
5.8	6.2	6.55	4 11/16	4B62Q	Q1	3 17/32	12.6
6.0	6.4	6.75	4 7/8	4B64Q	Q1	3 17/32	14.1
6.2	6.6	6.95	5 1/16	4B66Q	Q1	3 17/32	14.8
6.4	6.8	7.15	5 1/4	4B68Q	Q1	3 17/32	16.9
15.0	15.4	15.75	13 7/8	4B154R	R1	3 25/32	40.1
15.6	16.0	16.35	14 1/2	4B160R	R1	3 25/32	44.0
18.0	18.4	18.75	16 7/8	4B184R	R1	3 25/32	50.3
19.5	20.0	20.35	18 1/2	4B200R	R1	3 25/32	54.0
24.5	25.0	25.35	23 1/2	4B250R	R1	3 25/32	71.0
29.5	30.0	30.35	28 1/2	4B300R	R1	3 25/32	99.0
37.5	38.0	38.35	36 1/2	4B380R	R1	3 25/32	126

For optimum sheave selection, see B5V® Stock Sheave Listing on pages 23-35.

**Table No.2**

DIAMETERS (in.)				5 Grooves, Face Width = 4"			
Datum "A"	Datum "B"	Outside	Inside	Part Number		Dimensions (in.)	Wt. Less Bush
				Sheave	Bushing	OL	
6.6	7.0	7.35	5 1/2	5B70R	R1	4 3/4	17.0
7.0	7.4	7.75	5 7/8	5B74R	R1	4 3/4	20.3
7.6	8.0	8.35	6 1/2	5B80R	R1	4 3/4	24.8
8.2	8.6	8.95	7 1/16	5B86R	R1	4 3/4	27.3
8.6	9.0	9.35	7 1/2	5B90R	R1	4 3/4	29.1
9.0	9.4	9.75	7 7/8	5B94R	R1	4 3/4	30.0
10.6	11.0	11.35	9 1/2	5B110R	R1	4 3/4	32.8
12.0	12.4	12.75	10 7/8	5B124R	R1	4 3/4	36.0
13.2	13.6	13.95	12 1/16	5B136R	R1	4 3/4	40.3
15.0	15.4	15.75	13 7/8	5B154R	R1	4 3/4	45.0
15.6	16.0	16.35	14 1/2	5B160R	R1	4 3/4	48.0
18.0	18.4	18.75	16 7/8	5B184R	R1	4 3/4	54.0
19.5	20.0	20.35	18 1/2	5B200R	R1	4 3/4	64.0
24.5	25.0	25.35	23 1/2	5B250R	R1	4 3/4	79.0
29.5	30.0	30.35	28 1/2	5B300R	R1	4 3/4	115
37.5	38.0	38.35	36 1/2	5B380R	R1	4 3/4	150

**Table No.3**

DIAMETERS (in.)				6 Grooves, Face Width = 4 3/4"			
Datum "A"	Datum "B"	Outside	Inside	Part Number		Dimensions (in.)	Wt. Less Bush
				Sheave	Bushing	OL	
6.6	7.0	7.35	5 1/2	6B70R	R1	4 3/4	19.0
7.0	7.4	7.75	5 7/8	6B74R	R1	4 3/4	21.8
7.6	8.0	8.35	6 1/2	6B80R	R1	4 3/4	26.8
8.2	8.6	8.95	7 1/16	6B86R	R1	4 3/4	29.4
8.6	9.0	9.35	7 1/2	6B90R	R1	4 3/4	31.4
9.0	9.4	9.75	7 7/8	6B94R	R1	4 3/4	32.8
10.6	11.0	11.35	9 1/2	6B110R	R1	4 3/4	37.0
12.0	12.4	12.75	10 7/8	6B124R	R1	4 3/4	39.4
13.2	13.6	13.95	12 1/16	6B136R	R1	4 3/4	45.3
15.0	15.4	15.75	13 7/8	6B154R	R1	4 3/4	49.1
15.6	16.0	16.35	14 1/2	6B160R	R1	4 3/4	52.0
18.0	18.4	18.75	16 7/8	6B184R	R1	4 3/4	59.0
19.5	20.0	20.35	18 1/2	6B200R	R1	4 3/4	69.0
24.5	25.0	25.35	23 1/2	6B250R	R1	4 3/4	83.0
29.5	30.0	30.35	28 1/2	6B300R	R1	4 3/4	126
37.5	38.0	38.35	36 1/2	6B380R	R1	4 3/4	170



- 2 - 8 grooves
- 5.75" - 38.35" O.D.
- 1/2" - 2 5/8" bore range
- Machined from fine grain cast iron
- Precision balanced
- Easy on - easy off

**Table No.4 Bushing Dimensions**

Part No.	Bore Range (in.)	Wt. Lbs.
Q1	3/4-2 11/16	3 1/2
R1	1 1/8-3 3/4	7 1/2

**Browning Split Taper Bushings**

- Keyed to shaft and hub. External key provides positive drive with no torque on the cap screws
- Highest torque carrying capacity in the Browning bushing product line
- Double split barrel assures true concentricity
- Inch, metric and spline bores available from stock

### B GRIPBELT® SHEAVES WITH BROWNING® SPLIT TAPER® BUSHINGS For Use with All "A" and "B" Section Belts

**Table No.1 Specifications - Stock "B" Sheaves**

DIAMETERS (in.)				Part Number		Dimensions (in.)		Wt. Less Bush.
Datum "A"	Datum "B"	Outside	Inside	Sheave	Bushing	O.L.		
<b>8 Grooves, Face Width = 6 1/4"</b>								
5.0	5.4	5.75	3 7/8	<b>8B54Q</b>	<b>Q2</b>	7 9/32	18.1	
5.2	5.6	5.95	4 1/16	<b>8B56Q</b>	<b>Q2</b>	7 9/32	20.6	
5.4	5.8	6.15	4 1/4	<b>8B58Q</b>	<b>Q2</b>	6 1/4	20.9	
5.6	6.0	6.35	4 7/16	<b>8B60Q</b>	<b>Q2</b>	6 1/4	23.0	
5.8	6.2	6.55	4 11/16	<b>8B62Q</b>	<b>Q2</b>	6 1/4	23.0	
6.0	6.4	6.75	4 7/8	<b>8B64Q</b>	<b>Q2</b>	6 1/4	25.0	
6.2	6.6	6.95	5 1/16	<b>8B66Q</b>	<b>Q2</b>	6 1/4	27.3	
6.4	6.8	7.15	5 1/4	<b>8B68Q</b>	<b>Q2</b>	6 1/4	31.1	
6.6	7.0	7.35	5 1/2	<b>8B70R</b>	<b>R2</b>	6 9/32	29.5	
7.0	7.4	7.75	5 7/8	<b>8B74R</b>	<b>R2</b>	6 9/32	34.9	
7.6	8.0	8.35	6 1/2	<b>8B80R</b>	<b>R2</b>	6 9/32	42.9	
8.2	8.6	8.95	7 1/16	<b>8B86R</b>	<b>R2</b>	6 9/32	52.0	
8.6	9.0	9.35	7 1/2	<b>8B90R</b>	<b>R2</b>	6 9/32	48.3	
9.0	9.4	9.75	7 7/8	<b>8B94R</b>	<b>R2</b>	6 9/32	49.3	
10.6	11.0	11.35	9 1/2	<b>8B110R</b>	<b>R2</b>	6 9/32	55.0	
12.0	12.4	12.75	10 7/8	<b>8B124R</b>	<b>R2</b>	6 9/32	60.0	
13.2	13.6	13.95	12 1/16	<b>8B136R</b>	<b>R2</b>	6 9/32	68.5	
15.0	15.4	15.75	13 7/8	<b>8B154R</b>	<b>R2</b>	6 9/32	77.3	
18.0	18.4	18.75	16 7/8	<b>8B184R</b>	<b>R2</b>	6 9/32	90.0	
19.5	20.0	20.35	18 1/2	<b>8B200R</b>	<b>R2</b>	6 9/32	96.0	
24.5	25.0	25.35	23 1/2	<b>8B250R</b>	<b>R2</b>	6 9/32	129	
29.5	30.0	30.35	28 1/2	<b>8B300R</b>	<b>R2</b>	6 9/32	163	
29.5	30.0	30.35	28 1/2	<b>8B300S</b>	<b>S1</b>	6 1/4	168	
37.5	38.0	38.35	36 1/2	<b>8B380R</b>	<b>R2</b>	6 9/32	228	
37.5	38.0	38.35	36 1/2	<b>8B380S</b>	<b>S1</b>	6 1/4	238	



- 2 - 8 grooves
- 5.75" - 38.35" O.D.
- 1/2" - 2 5/8" bore range
- Machined from fine grain cast iron
- Precision balanced
- Easy on - easy off

**Table No.2 Standard Keyseats**

Bore Range (in.)	Keyseat (in.)
1-1 1/4	1/4 x 1/8
1 5/16-1 3/8	5/16 x 5/32
1 7/16-1 3/4	3/8 x 3/16
1 13/16-2 1/4	1/2 x 1/4
2 5/16-2 3/4	5/8 x 5/16
2 13/16-3 1/4	3/4 x 3/8
3 3/8-3 5/8	7/8 x 7/16
3 7/8-4 1/2	1 x 1/2
4 5/8-5 1/2	1 1/4 x 5/8

1 3/8" bore bushings also available with 3/8" x 3/16" keyseat.

**Table No.3 Bushing Dimensions**

Part No.	Bore Range (in.)	Wt. Lbs.
<b>Q2</b>	1-2 5/8	4 1/2
<b>R2</b>	1 3/8-3 5/8	11
<b>S1</b>	1 11/16-4 1/4	13 1/2
<b>U0</b>	2 3/8-3 3/16	30
<b>U0</b>	3 1/4-5 1/2	27

**Browning Split Taper Bushings**

- Keyed to shaft and hub. External key provides positive drive with no torque on the cap screws
- Highest torque carrying capacity in the Browning bushing product line
- Double split barrel assures true concentricity
- Inch, metric and spline bores available from stock

## TC GRIPBELT® SHEAVES WITH BROWNING® SPLIT TAPER® BUSHINGS

For Use with All "C" Section Belts

**Table No.1 Specifications - Stock "TC" Sheaves**

DIAMETERS (in.)			1 Groove, Face Width = 1 1/4"			
Datum "C"	Outside	Inside	Part Number		Dimensions (in.)	Wt. Less Bush.
			Sheave	Bushing	O.L.	
7.0	7.40	-	<b>1TC70</b>	<b>Q1</b>	2 25/32	9.3
7.2	7.60	-	<b>1TC72</b>	<b>Q1</b>	2 25/32	10.1
7.4	7.80	-	<b>1TC74</b>	<b>Q1</b>	2 25/32	10.8
7.6	8.00	-	<b>1TC76</b>	<b>Q1</b>	2 25/32	11.4
7.8	8.20	6	<b>1TC78</b>	<b>Q1</b>	2 25/32	9.8
8.0	8.40	6 1/4	<b>1TC80</b>	<b>Q1</b>	2 25/32	9.9
8.2	8.60	6 7/16	<b>1TC82</b>	<b>Q1</b>	2 25/32	10.1
8.4	8.80	6 5/8	<b>1TC84</b>	<b>Q1</b>	2 25/32	11.0
8.6	9.00	6 13/16	<b>1TC86</b>	<b>Q1</b>	2 25/32	10.6
8.8	9.20	7	<b>1TC88</b>	<b>Q1</b>	2 25/32	11.6
9.0	9.40	7 1/4	<b>1TC90</b>	<b>Q1</b>	2 25/32	11.4
9.2	9.60	7 7/16	<b>1TC92</b>	<b>Q1</b>	2 25/32	12.6
9.4	9.80	7 5/8	<b>1TC94</b>	<b>Q1</b>	2 25/32	14.8
9.6	10.00	7 13/16	<b>1TC96</b>	<b>Q1</b>	2 25/32	15.8
9.8	10.20	8	<b>1TC98</b>	<b>Q1</b>	2 25/32	15.9
10.0	10.40	8 1/4	<b>1TC100</b>	<b>Q1</b>	2 25/32	16.8
10.2	10.60	8 7/16	<b>1TC102</b>	<b>Q1</b>	2 25/32	16.1
10.6	11.00	8 13/16	<b>1TC106</b>	<b>Q1</b>	2 25/32	17.3
11.0	11.40	9 1/4	<b>1TC110</b>	<b>Q1</b>	2 25/32	17.5
11.4	11.80	9 5/8	<b>1TC114</b>	<b>Q1</b>	2 25/32	18.6
12.0	12.40	10 1/4	<b>1TC120</b>	<b>Q1</b>	2 25/32	19.5
13.0	13.40	11 1/4	<b>1TC130</b>	<b>Q1</b>	2 25/32	22.8
16.0	16.40	14 1/4	<b>1TC160</b>	<b>Q1</b>	2 25/32	28.5
20.0	20.40	18 1/4	<b>1TC200</b>	<b>Q1</b>	2 25/32	37.8
24.0	24.40	22 1/4	<b>1TC240</b>	<b>Q1</b>	2 25/32	49.5



- 1 - 6 grooves
- 7.40" - 24.40" O.D.
- 1/2" - 2 5/8" bore range
- Machined from fine grain cast iron
- Precision balanced
- Easy on - easy off

**Table No.2 Standard Keyseats**

Bore Range (in.)	Keyseat (in.)
3/4-7/8	3/16 x 3/32
15/16-1 1/4	1/4 x 1/8
1 5/16-1 3/8	5/16 x 5/32
1 7/16-1 3/4	3/8 x 3/16
1 13/16-2 1/4	1/2 x 1/4
2 5/16-2 11/16	5/8 x 5/16

1 3/8" bore bushings also available with 3/8" x 3/16" keyseat.

**Table No.3 Bushing Dimensions**

Part No.	Bore Range (in.)	Wt. Lbs.
<b>Q1</b>	3/4-2 11/16	3 1/2

### Browning Split Taper Bushings

- Keyed to shaft and hub.  
External key provides positive drive with no torque on the cap screws
- Highest torque carrying capacity in the Browning bushing product line
- Double split barrel assures true concentricity
- Inch, metric and spline bores available from stock

### TC GRIPBELT® SHEAVES WITH BROWNING® SPLIT TAPER® BUSHINGS

For Use with All "C" Section Belts

**Table No.1 Specifications - Stock "TC" Sheaves**

DIAMETERS (in.)			2 Grooves, Face Width = 2 1/4"			
Datum "C"	Outside	Inside	Part Number		Dimensions (in.)	Wt. Less Bush.
			Sheave	Bushing	O.L.	
7.0	7.40	5 1/4	2TC70	Q1	3 1/32	14.0
7.2	7.60	5 7/16	2TC72	Q1	3 1/32	15.4
7.4	7.80	5 5/8	2TC74	Q1	3 1/32	16.6
7.6	8.00	5 13/16	2TC76	Q1	3 1/32	17.6
7.8	8.20	6	2TC78	Q1	3 1/32	14.1
8.0	8.40	6 1/4	2TC80	Q1	3 1/32	14.3
8.2	8.60	6 7/16	2TC82	Q1	3 1/32	14.8
8.4	8.80	6 5/8	2TC84	Q1	3 1/32	16.4
8.6	9.00	6 13/16	2TC86	Q1	3 1/32	16.1
8.8	9.20	7	2TC88	Q1	3 1/32	17.1
9.0	9.40	7 1/4	2TC90	Q1	3 1/32	16.8
9.2	9.60	7 7/16	2TC92	Q1	3 1/32	18.4
9.4	9.80	7 5/8	2TC94	Q1	3 1/32	19.1
9.6	10.00	7 13/16	2TC96	Q1	3 1/32	20.6
9.8	10.20	8	2TC98	Q1	3 1/32	19.5
10.0	10.40	8 1/4	2TC100	Q1	3 1/32	22.0
10.2	10.60	8 7/16	2TC102	Q1	3 1/32	21.3
10.6	11.00	8 13/16	2TC106	Q1	3 1/32	22.4
11.0	11.40	9 1/4	2TC110	Q1	3 1/32	22.4
11.4	11.80	9 5/8	2TC114	Q1	3 1/32	23.5
12.0	12.40	10 1/4	2TC120	Q1	3 1/32	24.9
13.0	13.40	11 1/4	2TC130	Q1	3 1/32	28.6
16.0	16.40	14 1/4	2TC160	Q1	3 1/32	36.0
20.0	20.40	18 1/4	2TC200	Q1	3 1/32	46.0
24.0	24.40	22 1/4	2TC240	Q1	3 1/32	59.5



"C" Belts  
7/8" x 17/32"



- 1 - 6 grooves
- 7.40" - 24.40" O.D.
- 1/2" - 2 5/8" bore range
- Machined from fine grain cast iron
- Precision balanced
- Easy on - easy off

**Table No.2**

DIAMETERS (in.)			3 Grooves, Face Width = 3 1/4"			
Datum "C"	Outside	Inside	Part Number		Dimensions (in.)	Wt. Less Bush.
			Sheave	Bushing	O.L.	
7.0	7.40	5 1/4	3TC70	Q1	3 17/32	16.8
7.2	7.60	5 7/16	3TC72	Q1	3 17/32	18.0
7.4	7.80	5 5/8	3TC74	Q1	3 17/32	19.1
7.6	8.00	5 13/16	3TC76	Q1	3 17/32	21.3
7.8	8.20	6	3TC78	Q1	3 17/32	17.4
8.0	8.40	6 1/4	3TC80	Q1	3 17/32	17.8
8.2	8.60	6 7/16	3TC82	Q1	3 17/32	17.9
8.4	8.80	6 5/8	3TC84	Q1	3 17/32	20.4
8.6	9.00	6 13/16	3TC86	Q1	3 17/32	19.5
8.8	9.20	7	3TC88	Q1	3 17/32	22.5
9.0	9.40	7 1/4	3TC90	Q1	3 17/32	20.4
9.2	9.60	7 7/16	3TC92	Q1	3 17/32	22.8
9.4	9.80	7 5/8	3TC94	Q1	3 17/32	23.0
9.6	10.00	7 13/16	3TC96	Q1	3 17/32	25.3
9.8	10.20	8	3TC98	Q1	3 17/32	24.4
10.0	10.40	8 1/4	3TC100	Q1	3 17/32	27.6
10.2	10.60	8 7/16	3TC102	Q1	3 17/32	24.9
10.6	11.00	8 13/16	3TC106	Q1	3 17/32	26.9
11.0	11.40	9 1/4	3TC110	Q1	3 17/32	27.4
11.4	11.80	9 5/8	3TC114	Q1	3 17/32	28.3
12.0	12.40	10 1/4	3TC120	Q1	3 17/32	30.3
13.0	13.40	11 1/4	3TC130	Q1	3 17/32	34.9
16.0	16.40	14 1/4	3TC160	Q1	3 17/32	46.0
20.0	20.40	18 1/4	3TC200	Q1	3 17/32	54.5
24.0	24.40	22 1/4	3TC240	Q1	3 17/32	71.0

**Table No.3 Bushing Dimensions**

Part No.	Bore Range (in.)	Wt. Lbs.
Q1	3/4-2 11/16	3 1/2

**Browning Split Taper Bushings**

- Keyed to shaft and hub. External key provides positive drive with no torque on the cap screws
- Highest torque carrying capacity in the Browning bushing product line
- Double split barrel assures true concentricity
- Inch, metric and spline bores available from stock

For additional product information, visit [www.regalrexnord.com/Browning](http://www.regalrexnord.com/Browning)

## TC GRIPBELT® SHEAVES WITH BROWNING® SPLIT TAPER® BUSHINGS

For Use with All "C" Section Belts

**Table No.1 Specifications - Stock "TC" Sheaves**

DIAMETERS (in.)			4 Grooves, Face Width = 4 1/4"			
Datum "C"	Outside	Inside	Part Number		Dimensions (in.)	Wt. Less Bush.
			Sheave	Bushing	O.L.	
7.0	7.40	5 1/4	4TC70	Q2	4 17/32	23.8
7.2	7.60	5 7/16	4TC72	Q2	4 17/32	26.8
7.4	7.80	5 5/8	4TC74	Q2	4 17/32	27.5
7.6	8.00	5 13/16	4TC76	Q2	4 17/32	30.3
7.8	8.20	6	4TC78	Q2	4 17/32	26.4
8.0	8.40	6 1/4	4TC80	Q2	4 17/32	29.0
8.2	8.60	6 7/16	4TC82	Q2	4 17/32	26.8
8.4	8.80	6 5/8	4TC84	Q2	4 17/32	28.8
8.6	9.00	6 13/16	4TC86	Q2	4 17/32	27.9
8.8	9.20	7	4TC88	Q2	4 17/32	31.6
9.0	9.40	7 1/4	4TC90	Q2	4 17/32	28.4
9.2	9.60	7 7/16	4TC92	Q2	4 17/32	32.3
9.4	9.80	7 5/8	4TC94	Q2	4 17/32	31.8
9.6	10.00	7 13/16	4TC96	Q2	4 17/32	35.2
9.8	10.20	8	4TC98	Q2	4 17/32	33.0
10.0	10.40	8 1/4	4TC100	Q2	4 17/32	37.0
10.2	10.60	8 7/16	4TC102	Q2	4 17/32	33.5
10.6	11.00	8 13/16	4TC106	Q2	4 17/32	36.3
11.0	11.40	9 1/4	4TC110	Q2	4 17/32	36.3
11.4	11.80	9 5/8	4TC114	Q2	4 17/32	38.4
12.0	12.40	10 1/4	4TC120	Q2	4 17/32	40.5
13.0	13.40	11 1/4	4TC130	Q2	4 17/32	43.6
16.0	16.40	14 1/4	4TC160	Q2	4 17/32	56.0
20.0	20.40	18 1/4	4TC200	Q2	4 17/32	72.0
24.0	24.40	22 1/4	4TC240	Q2	4 17/32	85.3



"C" Belts  
7/8" x 17/32"

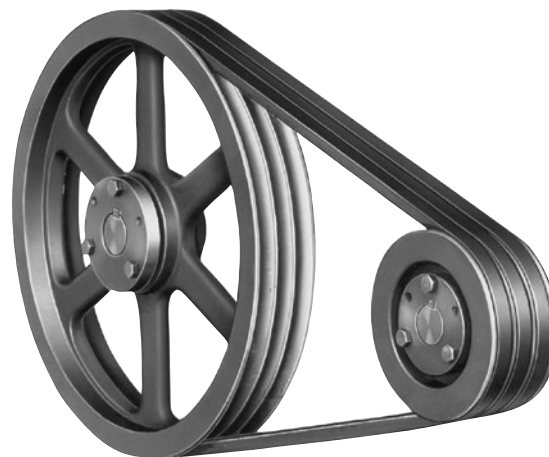

- 1 - 6 grooves
- 7.40" - 24.40" O.D.
- 1/2" - 2 5/8" bore range
- Machined from fine grain cast iron
- Precision balanced
- Easy on - easy off

**Table No.2 Standard Keyseats**

Bore Range (in.)	Keyseat (in.)
1-1 1/4	1/4 x 1/8
1 5/16-1 3/8	5/16 x 5/32
1 7/16-1 3/4	3/8 x 3/16
1 13/16-2 1/4	1/2 x 1/4
2 5/16-2 5/8	5/8 x 5/16

1 3/8" bore bushings also available with 3/8" x 3/16" keyseat.

**Table No.3 Bushing Dimensions**

Part No.	Bore Range (in.)	Wt. Lbs.
Q2	1-2 5/8	4 1/2

### Browning Split Taper Bushings

- Keyed to shaft and hub. External key provides positive drive with no torque on the cap screws
- Highest torque carrying capacity in the Browning bushing product line
- Double split barrel assures true concentricity
- Inch, metric and spline bores available from stock

## TC GRIPBELT® SHEAVES WITH BROWNING® SPLIT TAPER® BUSHINGS

For Use with All "C" Section Belts

**Table No.1 Specifications - Stock "TC" Sheaves**

DIAMETERS (in.)			5 Grooves, Face Width = 5 1/4"			
Datum "C"	Outside	Inside	Part Number		Dimensions (in.)	Wt. Less Bush.
			Sheave	Bushing	O.L.	
7.0	7.40	5 1/4	5TC70	Q2	5 1/4	27.5
7.2	7.60	5 7/16	5TC72	Q2	5 1/4	29.8
7.4	7.80	5 5/8	5TC74	Q2	5 1/4	31.0
7.6	8.00	5 13/16	5TC76	Q2	5 1/4	34.3
7.8	8.20	6	5TC78	Q2	5 1/4	30.0
8.0	8.40	6 1/4	5TC80	Q2	5 1/4	33.4
8.2	8.60	6 7/16	5TC82	Q2	5 1/4	30.3
8.4	8.80	6 5/8	5TC84	Q2	5 1/4	32.8
8.6	9.00	6 13/16	5TC86	Q2	5 1/4	31.0
8.8	9.20	7	5TC88	Q2	5 1/4	34.9
9.0	9.40	7 1/4	5TC90	Q2	5 1/4	32.6
9.2	9.60	7 7/16	5TC92	Q2	5 1/4	36.4
9.4	9.80	7 5/8	5TC94	Q2	5 1/4	35.6
9.6	10.00	7 13/16	5TC96	Q2	5 1/4	39.1
9.8	10.20	8	5TC98	Q2	5 1/4	37.3
10.0	10.40	8 1/4	5TC100	Q2	5 1/4	42.3
10.2	10.60	8 7/16	5TC102	Q2	5 1/4	39.4
10.6	11.00	8 13/16	5TC106	Q2	5 1/4	41.0
11.0	11.40	9 1/4	5TC110	Q2	5 1/4	42.4
11.4	11.80	9 5/8	5TC114	Q2	5 1/4	42.8
12.0	12.40	10 1/4	5TC120	Q2	5 1/4	46.3
13.0	13.40	11 1/4	5TC130	Q2	5 1/4	49.5
16.0	16.40	14 1/4	5TC160	Q2	5 1/4	64.5
20.0	20.40	18 1/4	5TC200	Q2	5 1/4	78.0
24.0	24.40	22 1/4	5TC240	Q2	5 1/4	96.0



"C" Belts  
7/8" x 17/32"

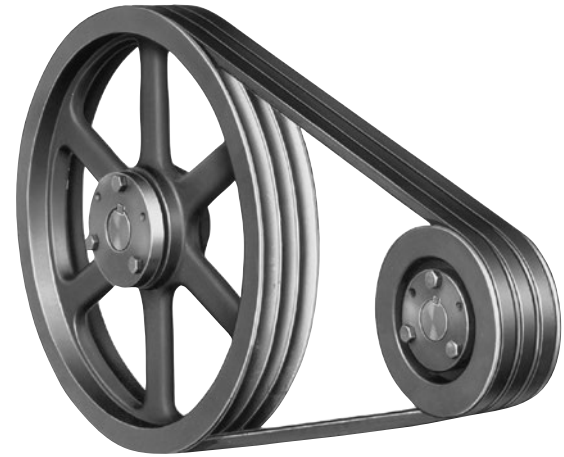

- 1 - 6 grooves
- 7.40" - 24.40" O.D.
- 1/2" - 2 5/8" bore range
- Machined from fine grain cast iron
- Precision balanced
- Easy on - easy off

**Table No.2**

DIAMETERS (in.)			6 Grooves, Face Width = 5 1/4"			
Datum "C"	Outside	Inside	Part Number		Dimensions (in.)	Wt. Less Bush.
			Sheave	Bushing	O.L.	
7.0	7.40	5 1/4	6TC70	Q2	6 1/4	29.9
7.2	7.60	5 7/16	6TC72	Q2	6 1/4	33.6
7.4	7.80	5 5/8	6TC74	Q2	6 1/4	33.3
7.6	8.00	5 13/16	6TC76	Q2	6 1/4	37.9
7.8	8.20	6	6TC78	Q2	6 1/4	33.5
8.0	8.40	6 1/4	6TC80	Q2	6 1/4	37.6
8.2	8.60	6 7/16	6TC82	Q2	6 1/4	34.0
8.4	8.80	6 5/8	6TC84	Q2	6 1/4	37.0
8.6	9.00	6 13/16	6TC86	Q2	6 1/4	35.0
8.8	9.20	7	6TC88	Q2	6 1/4	39.4
9.0	9.40	7 1/4	6TC90	Q2	6 1/4	36.8
9.2	9.60	7 7/16	6TC92	Q2	6 1/4	41.0
9.4	9.80	7 5/8	6TC94	Q2	6 1/4	39.4
9.6	10.00	7 13/16	6TC96	Q2	6 1/4	43.6
9.8	10.20	8	6TC98	Q2	6 1/4	42.0
10.0	10.40	8 1/4	6TC100	Q2	6 1/4	47.3
10.2	10.60	8 7/16	6TC102	Q2	6 1/4	44.4
10.6	11.00	8 13/16	6TC106	Q2	6 1/4	45.4
11.0	11.40	9 1/4	6TC110	Q2	6 1/4	47.0
11.4	11.80	9 5/8	6TC114	Q2	6 1/4	49.6
12.0	12.40	10 1/4	6TC120	Q2	6 1/4	51.0
13.0	13.40	11 1/4	6TC130	Q2	6 1/4	56.0
16.0	16.40	14 1/4	6TC160	Q2	6 1/4	72.0
20.0	20.40	18 1/4	6TC200	Q2	6 1/4	88.3
24.0	24.40	22 1/4	6TC240	Q2	6 1/4	108

**Table No.3 Bushing Dimensions**

Part No.	Bore Range (in.)	Wt. Lbs.
Q2	1-2 5/8	4 1/2

**Browning Split Taper Bushings**

- Keyed to shaft and hub. External key provides positive drive with no torque on the cap screws
- Highest torque carrying capacity
- Double split barrel assures true concentricity
- Inch, metric and spline bores available from stock

For additional product information, visit [www.regalrexnord.com/Browning](http://www.regalrexnord.com/Browning)

## C GRIPBELT® SHEAVES WITH BROWNING® SPLIT TAPER® BUSHINGS

For Use with All "C" Section Belts

**Table No.1 Specifications - Stock "C" Sheaves**

DIAMETERS (in.)			Part Number		Dimensions (in.)	Wt. (lbs.) less Bush.
Datum "C"	Outside	Inside	Sheave	Bushing	OL	
<b>1 Groove, Face Width = 1 1/4"</b>						
5.6	6.00	-	1C56P	P1	2 3/16	6.0
6.0	6.40	-	1C60Q	Q1	2 25/32	6.1
<b>2 Grooves, Face Width = 2 1/4"</b>						
5.6	6.00	3 13/16	2C56P	P1	2 1/2	8.4
6.0	6.40	4 1/4	2C60Q	Q1	2 25/32	9.5
14.0	14.40	12 1/4	2C140R	R1	3 9/32	33.5
18.0	18.40	16 1/4	2C180R	R1	3 9/32	42.3
27.0	27.40	25 1/4	2C270R	R1	3 9/32	77.0
30.0	30.40	28 1/8	2C300R	R1	3 9/32	93.0
36.0	36.40	34 1/8	2C360R	R1	3 9/32	117.0
44.0	44.40	42 1/8	2C440R	R1	3 9/32	164.0
<b>3 Grooves, Face Width = 3 1/4"</b>						
5.0	5.40	-	3C50Q	Q1	4 9/32	8.4
5.6	6.00	3 13/16	3C56P	P2	3 1/2	12.9
6.0	6.40	4 1/4	3C60Q	Q1	3 17/32	11.8
9.0	9.40	7 3/16	3C90R	R1	3 25/32	27.3
9.2	9.60	7 3/8	3C92R	R1	3 25/32	27.5
9.4	9.80	7 5/8	3C94R	R1	3 25/32	26.9
9.6	10.00	7 13/16	3C96R	R1	3 25/32	28.4
9.8	10.20	8	3C98R	R1	3 25/32	29.3
10.0	10.40	8 3/16	3C100R	R1	3 25/32	29.0
10.2	10.60	8 3/8	3C102R	R1	3 25/32	31.4
10.6	11.00	8 13/16	3C106R	R1	3 25/32	31.8
11.0	11.40	9 1/4	3C110R	R1	3 25/32	29.3
12.0	12.40	10 1/4	3C120R	R1	3 25/32	36.9
13.0	13.40	11 1/4	3C130R	R1	3 25/32	34.8
14.0	14.40	12 1/4	3C140R	R1	3 25/32	39.4
15.0	15.40	13 1/4	3C150R	R1	3 25/32	43.8
16.0	16.40	14 1/4	3C160R	R1	3 25/32	47.0
18.0	18.40	16 1/4	3C180R	R1	3 25/32	51.5
20.0	20.40	18 1/4	3C200R	R1	3 25/32	58.0
24.0	24.40	22 1/4	3C240R	R1	3 25/32	71.0
27.0	27.40	25 1/4	3C270R	R1	3 25/32	92.0
30.0	30.40	28 1/8	3C300R	R1	3 25/32	110.0
36.0	36.40	34 1/8	3C360R	R1	3 25/32	135.0
44.0	44.40	42 1/8	3C440R	R1	3 25/32	196.0
50.0	50.40	48 1/8	3C500R	R1	3 25/32	213.0
50.0	50.40	48 1/8	3C500S	S1	4 3/4	224.0
<b>4 Grooves, Face Width = 4 1/4"</b>						
5.0	5.40	-	4C50Q	Q2	5 9/32	10.9
5.6	6.00	3 13/16	4C56P	P2	4 1/2	15.4
6.0	6.40	4 1/4	4C60Q	Q2	4 17/32	17.0
9.0	9.40	7 3/16	4C90R	R1	4 9/32	30.0
9.2	9.60	7 3/8	4C92R	R1	4 9/32	31.6
9.4	9.80	7 5/8	4C94R	R1	4 9/32	31.6
9.6	10.00	7 13/16	4C96R	R1	4 9/32	31.1
9.8	10.20	8	4C98R	R1	4 9/32	33.4
10.0	10.40	8 3/16	4C100R	R1	4 9/32	34.1
10.2	10.60	8 3/8	4C102R	R1	4 9/32	36.5
10.6	11.00	8 13/16	4C106R	R1	4 9/32	36.5
11.0	11.40	9 1/4	4C110R	R1	4 9/32	33.0
12.0	12.40	10 1/4	4C120R	R1	4 9/32	42.9
13.0	13.40	11 1/4	4C130R	R1	4 9/32	40.1
14.0	14.40	12 1/4	4C140R	R1	4 9/32	46.6
15.0	15.40	13 1/4	4C150R	R1	4 9/32	52.0
16.0	16.40	14 1/4	4C160R	R1	4 9/32	55.0
18.0	18.40	16 1/4	4C180R	R1	4 9/32	60.0
18.0	18.40	16 1/4	4C180S	S1	5 7/32	92.0
20.0	20.40	18 1/4	4C200R	R1	4 9/32	69.0
20.0	20.40	18 1/4	4C200S	S1	5 7/32	103.0
24.0	24.40	22 1/4	4C240R	R1	4 9/32	86.0
24.0	24.40	22 1/4	4C240S	S1	5 7/32	120.0
27.0	27.40	25 1/4	4C270R	R1	4 9/32	110.0
27.0	27.40	25 1/4	4C270S	S1	5 7/32	123.0
30.0	30.40	28 1/8	4C300R	R1	4 9/32	123.0
30.0	30.40	28 1/8	4C300S	S1	5 7/32	142.0
36.0	36.40	34 1/8	4C360R	R1	4 9/32	156.0
36.0	36.40	34 1/8	4C360S	S1	5 7/32	183.0
44.0	44.40	42 1/8	4C440R	R1	4 9/32	218.0
44.0	44.40	42 1/8	4C440U	U0	5 13/32	241.0
50.0	50.40	48 1/8	4C500R	R1	4 9/32	240.0
50.0	50.40	48 1/8	4C500U	U0	5 13/32	283.0



"C" Belts  
7/8" x 17/32"



- 1 - 8 grooves
- 6.00" - 50.40" O.D.
- 1/2" - 5 1/2" bore range
- Machined from fine grain cast iron
- Precision balanced
- Easy on - easy off

**Table No.2 Standard Keyseats**

Bore Range (in.)	Keyseat (in.)
1/2-1 3/4	1/8 x 1/16
5/8-7/8	3/16 x 3/32
15/16-1 1/4	1/4 x 1/8
1 5/16-1 3/8	5/16 x 5/32
1 7/16-1 3/4	3/8 x 3/16
1 13/16-2 1/4	1/2 x 1/4
2 5/16-2 3/4	5/8 x 5/16
2 13/16-3 1/4	3/4 x 3/8
3 3/8-3 3/4	7/8 x 7/16
3 7/8-4 1/2	1 x 1/2

1 3/8" bore bushings also available with 3/8" x 3/16" keyseat.

**Table No.3 Bushing Dimensions**

Part No.	Bore Range (in.)	Wt. Lbs.
P1	1/2-1 3/4	1 1/4
P2	3/4-1 3/4	1 1/2
Q1	3/4-2 11/16	3 1/2
Q2	1-2 5/8	4 1/2
Q3	1 3/8-2 1/2	5 1/2
R1	1 1/8-3 3/4	7 1/2
R2	1 3/8-3 5/8	11
S1	1 11/16-4 1/4	13 1/2
S2	1 7/8-4 3/16	19
U0	2 3/8-3 3/16	30
U0	3 1/4-5 1/2	27

**Browning Split Taper Bushings**

- Keyed to shaft and hub. External key provides positive drive with no torque on the cap screws
- Highest torque carrying capacity in the Browning bushing product line
- Double split barrel assures true concentricity
- Inch, metric and spline bores available from stock

## C GRIPBELT® SHEAVES WITH BROWNING® SPLIT TAPER® BUSHINGS

For Use with All "C" Section Belts

**Table No.1 Specifications - Stock "C" Sheaves**

DIAMETERS (in.)			Part Number		Dimensions (in.)	Wt.
Datum "C"	Outside	Inside	Sheave	Bushing	OL	Less Bush.
<b>5 Grooves, Face Width = 5 1/4"</b>						
9.0	9.40	7 3/16	5C90R	R1	5 1/4	33.4
9.2	9.60	7 3/8	5C92R	R1	5 1/4	36.8
9.4	9.80	7 5/8	5C94R	R1	5 1/4	35.8
9.6	10.00	7 13/16	5C96R	R1	5 1/4	35.4
9.8	10.20	8	5C98R	R1	5 1/4	37.6
10.0	10.40	8 3/16	5C100R	R1	5 1/4	38.9
10.2	10.60	8 3/8	5C102R	R1	5 1/4	40.6
10.6	11.00	8 13/16	5C106R	R1	5 1/4	39.0
11.0	11.40	9 1/4	5C110R	R1	5 1/4	38.8
12.0	12.40	10 1/4	5C120R	R1	5 1/4	47.5
13.0	13.40	11 1/4	5C130R	R1	5 1/4	46.0
14.0	14.40	12 1/4	5C140R	R1	5 1/4	52.0
15.0	15.40	13 1/4	5C150R	R1	5 1/4	54.0
16.0	16.40	14 1/4	5C160R	R1	5 1/4	63.0
18.0	18.40	16 1/4	5C180R	R1	5 1/4	69.0
18.0	18.40	16 1/4	5C180S	S1	5 23/32	100
20.0	20.40	18 1/4	5C200R	R1	5 1/4	77.0
20.0	20.40	18 1/4	5C200S	S1	5 23/32	99.0
24.0	24.40	22 1/4	5C240R	R1	5 1/4	110
24.0	24.40	22 1/4	5C240S	S1	5 23/32	129
27.0	27.40	25 1/4	5C270R	R2	5 25/32	131
30.0	30.40	28 1/8	5C300R	R2	5 25/32	150
30.0	30.40	28 1/8	5C300S	S1	5 23/32	160
36.0	36.40	34 1/8	5C360R	R2	5 25/32	194
44.0	44.40	42 1/8	5C440R	R2	5 25/32	243
50.0	50.40	48 1/8	5C500R	R2	5 25/32	273
<b>6 Grooves, Face Width = 6 1/4"</b>						
9.0	9.40	7 3/16	6C90R	R2	6 9/32	53.0
9.2	9.60	7 3/8	6C92R	R2	6 9/32	58.0
9.4	9.80	7 5/8	6C94R	R2	6 9/32	63.5
9.6	10.00	7 13/16	6C96R	R2	6 9/32	55.0
9.8	10.20	8	6C98R	R2	6 9/32	65.0
10.0	10.40	8 3/16	6C100R	R2	6 9/32	62.0
10.2	10.60	8 3/8	6C102R	R2	6 9/32	68.0
10.6	11.00	8 13/16	6C106R	R2	6 9/32	55.0
11.0	11.40	9 1/4	6C110R	R2	6 9/32	51.5
12.0	12.40	10 1/4	6C120R	R2	6 9/32	64.0
13.0	13.40	11 1/4	6C130R	R2	6 9/32	61.0
14.0	14.40	12 1/4	6C140R	R2	6 9/32	69.0
15.0	15.40	13 1/4	6C150R	R2	6 9/32	68.0
16.0	16.40	14 1/4	6C160R	R2	6 9/32	77.0
18.0	18.40	16 1/4	6C180R	R2	6 9/32	84.0
18.0	18.40	16 1/4	6C180S	S1	6 1/4	107
20.0	20.40	18 1/4	6C200R	R2	6 9/32	91.5
20.0	20.40	18 1/4	6C200S	S1	6 1/4	127
24.0	24.40	22 1/4	6C240R	R2	6 9/32	116
24.0	24.40	22 1/4	6C240S	S1	6 1/4	125
27.0	27.40	25 1/4	6C270R	R2	6 9/32	144
27.0	27.40	25 1/4	6C270S	S1	6 1/4	151
30.0	30.40	28 1/8	6C300R	R2	6 9/32	160
30.0	30.40	28 1/8	6C300U	U0	6 1/4	191
36.0	36.40	34 1/8	6C360R	R2	6 9/32	211
36.0	36.40	34 1/8	6C360U	U0	6 1/4	233
44.0	44.40	42 1/8	6C440R	R2	6 9/32	286
50.0	50.40	48 1/8	6C500R	R2	6 9/32	303
<b>7 Grooves, Face Width = 7 1/4"</b>						
7.0	7.40	5 3/8	7C70Q	Q3	7 1/4	37.5
8.0	8.40	6 3/8	7C80R	R2	7 1/4	45.6
8.6	9.00	6 15/16	7C86R	R2	7 1/4	52.8
9.0	9.40	7 3/16	7C90R	R2	7 1/4	58.0
9.2	9.60	7 3/8	7C92R	R2	7 1/4	63.0
9.4	9.80	7 5/8	7C94R	R2	7 1/4	68.0
9.8	10.20	8	7C98R	R2	7 1/4	73.0
10.0	10.40	8 3/16	7C100R	R2	7 1/4	71.0
10.2	10.60	8 3/8	7C102R	R2	7 1/4	76.0
10.6	11.00	8 13/16	7C106R	R2	7 1/4	71.0
11.0	11.40	9 1/4	7C110R	R2	7 1/4	68.0
12.0	12.40	10 1/4	7C120R	R2	7 1/4	67.0
13.0	13.40	11 1/4	7C130R	R2	7 1/4	84.0
14.0	14.40	12 1/4	7C140R	R2	7 1/4	83.0
15.0	15.40	13 1/4	7C150R	R2	7 1/4	86.0
16.0	16.40	14 1/4	7C160R	R2	7 1/4	88.0
18.0	18.40	16 1/4	7C180S	S2	7 29/32	137
18.0	18.40	16 1/4	7C180U	U0	7 1/4	133
20.0	20.40	18 1/4	7C200S	S2	7 29/32	152
20.0	20.40	18 1/4	7C200U	U0	7 1/4	144
24.0	24.40	22 1/4	7C240S	S2	7 29/32	173
27.0	27.40	25 1/4	7C270S	S2	7 29/32	197
27.0	27.40	25 1/4	7C270U	U0	7 1/4	196
30.0	30.40	28 1/8	7C300S	S2	7 29/32	220
30.0	30.40	28 1/8	7C300U	U0	7 1/4	217
36.0	36.40	34 1/8	7C360S	S2	7 29/32	279
44.0	44.40	42 1/8	7C440S	S2	7 29/32	337
50.0	50.40	48 1/8	7C500S	S2	7 29/32	382



"C" Belts  
7/8" x 17/32"

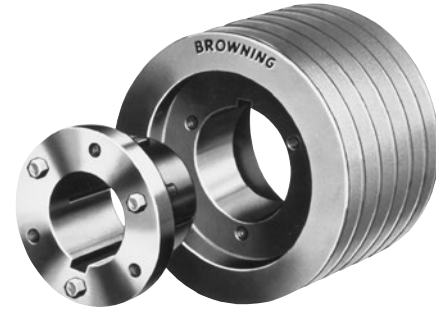

- 1 - 8 grooves
- 6.00" - 50.40" O.D.
- 1/2" - 5 1/2" bore range
- Machined from fine grain cast iron
- Precision balanced
- Easy on - easy off

**Table No.2 Standard Keyseats**

Bore Range (in.)	Keyseat (in.)
1/2-1 3/4	1/8 x 1/16
5/8-7/8	3/16 x 3/32
15/16-1 1/4	1/4 x 1/8
1 5/16-1 3/8	5/16 x 5/32
1 7/16-1 3/4	3/8 x 3/16
1 13/16-2 1/4	1/2 x 1/4
2 5/16-2 3/4	5/8 x 5/16
2 13/16-3 1/4	3/4 x 3/8
3 3/8-3 3/4	7/8 x 7/16
3 7/8-4 1/2	1 x 1/2
4 5/8-5 1/2	1 1/4 x 5/8

1 3/8" bore bushings also available with 3/8" x 3/16" keyseat.

**Table No.3 Bushing Dimensions**

Part No.	Bore Range (in.)	Wt. Lbs.
P1	1/2-1 3/4	1 1/4
P2	3/4-1 3/4	1 1/2
Q1	3/4-2 11/16	3 1/2
Q2	1-2 5/8	4 1/2
Q3	1 3/8-2 1/2	5 1/2
R1	1 1/8-3 3/4	7 1/2
R2	1 3/8-3 5/8	11
S1	1 11/16-4 1/4	13 1/2
S2	1 7/8-4 3/16	19
U0	2 3/8-3 3/16	30
U0	3 1/4-5 1/2	27

**Browning Split Taper Bushings**

- Keyed to shaft and hub. External key provides positive drive with no torque on the cap screws
- Highest torque carrying capacity in the Browning bushing product line
- Double split taper assures true concentricity
- Inch, metric and spline bores available from stock

## C GRIPBELT® SHEAVES WITH BROWNING® SPLIT TAPER® BUSHINGS

For Use with All "C" Section Belts

**Table No.1 Specifications - Stock "C" Sheaves**

DIAMETERS (in.)			Part Number		Dimensions (in.)	Wt.
Datum "C"	Outside	Inside	Sheave	Bush- ing	O.L.	Less Bush.
<b>8 Grooves, Face Width = 8 1/4"</b>						
7.0	7.40	5 3/8	<b>8C70Q</b>	<b>Q3</b>	8 1/4	40
8.0	8.40	6 3/8	<b>8C80R</b>	<b>R2</b>	8 1/4	49
8.6	9.00	6 15/16	<b>8C86R</b>	<b>R2</b>	8 1/4	57
9.0	9.40	7 3/16	<b>8C90R</b>	<b>R2</b>	8 1/4	62
9.2	9.60	7 3/8	<b>8C92R</b>	<b>R2</b>	8 1/4	68
9.4	9.80	7 5/8	<b>8C94R</b>	<b>R2</b>	8 1/4	73
9.6	10.00	7 13/16	<b>8C96R</b>	<b>R2</b>	8 1/4	70
9.8	10.20	8	<b>8C98R</b>	<b>R2</b>	8 1/4	76
10.0	10.40	8 3/16	<b>8C100R</b>	<b>R2</b>	8 1/4	72
10.2	10.60	8 3/8	<b>8C102R</b>	<b>R2</b>	8 1/4	79
10.6	11.00	8 13/16	<b>8C106R</b>	<b>R2</b>	8 1/4	76
11.0	11.40	9 1/4	<b>8C110R</b>	<b>R2</b>	8 1/4	73
12.0	12.40	10 1/4	<b>8C120R</b>	<b>R2</b>	8 1/4	74
13.0	13.40	11 1/4	<b>8C130R</b>	<b>R2</b>	8 1/4	80
14.0	14.40	12 1/4	<b>8C140R</b>	<b>R2</b>	8 1/4	84
15.0	15.40	13 1/4	<b>8C150R</b>	<b>R2</b>	8 1/4	93
16.0	16.40	14 1/4	<b>8C160R</b>	<b>R2</b>	8 1/4	100
18.0	18.40	16 1/4	<b>8C180S</b>	<b>S2</b>	8 13/32	140
18.0	18.40	16 1/4	<b>8C180U</b>	<b>U0</b>	8 1/4	141
20.0	20.40	18 1/4	<b>8C200S</b>	<b>S2</b>	8 13/32	163
20.0	20.40	18 1/4	<b>8C200U</b>	<b>U0</b>	8 1/4	160
24.0	24.40	22 1/4	<b>8C240S</b>	<b>S2</b>	8 13/32	194
24.0	24.40	22 1/4	<b>8C240U</b>	<b>U0</b>	8 1/4	184
27.0	27.40	25 1/4	<b>8C270S</b>	<b>S2</b>	8 13/32	224
30.0	30.40	28 1/4	<b>8C300S</b>	<b>S2</b>	8 13/32	212
30.0	30.40	28 1/8	<b>8C300U</b>	<b>U0</b>	8 1/4	227
36.0	36.40	34 1/8	<b>8C360S</b>	<b>S2</b>	8 13/32	261
36.0	36.40	34 1/8	<b>8C360U</b>	<b>U0</b>	8 1/4	288
44.0	44.40	42 1/8	<b>8C440S</b>	<b>S2</b>	8 13/32	368
44.0	44.40	42 1/8	<b>8C440U</b>	<b>U0</b>	8 1/4	358
50.0	50.40	48 1/8	<b>8C500S</b>	<b>S2</b>	8 13/32	429
50.0	50.40	48 1/8	<b>8C500U</b>	<b>U0</b>	8 1/4	417



"C" Belts  
7/8" x 17/32"



- 1 - 8 grooves
- 6.00" - 50.40" O.D.
- 1/2" - 5 1/2" bore range
- Machined from fine grain cast iron
- Precision balanced
- Easy on - easy off

**Table No.2 Standard Keyseats**

Bore Range (in.)	Keyseat (in.)
1 3/8	5/16 X 5/32
1 7/16 - 1 3/4	3/8 X 3/16
1 13/16 - 2 1/4	1/2 X 1/4
2 5/16 - 2 3/4	5/8 X 5/16
2 13/16 - 3 1/4	3/4 X 3/8
3 3/8 - 3 3/4	7/8 X 7/16
3 7/8 - 4 1/2	1 X 1/2
4 5/8 - 5 1/2	1 1/4 X 5/8

1 3/8" bore bushings also available with 3/8" x 3/16" keyseat.

**Table No.3 Bushing Dimensions**

Part Number	Bore Range (in.)	Wt. Lbs.
<b>Q3</b>	1 3/8 - 2 1/2	5 1/2
<b>R2</b>	1 3/8 - 3 5/8	11
<b>S2</b>	1 7/8 - 4 3/16	19
<b>U0</b>	2 3/8 - 3 3/16	30
<b>U0</b>	3 1/4 - 5 1/2	27
<b>U1</b>	2 3/4 - 5 1/2	40

**Browning Split Taper Bushings**

- Keyed to shaft and hub. External key provides positive drive with no torque on the cap screws
- Highest torque carrying capacity in the Browning bushing product line
- Double split barrel assures true concentricity
- Inch, metric and spline bores available from stock

## "358" GRIPBELT® DRIVES

### MORE HORSEPOWER IN LESS SPACE

Browning® "358" Gripbelt Drives combine the improved performance characteristics of today's higher quality synthetic materials with a more compact cross-section to provide an efficient mode of power transmission. Because of the significantly higher capacity of these belts, drives are designed with shorter center distances and smaller sheaves. Overall drive dimensions are reduced by as much as 40%; weight savings of up to 25% are achievable. All material savings are reflected in the lower cost of the drives.

Browning "358" Gripbelt Drives are furnished in only three cross-sections to cover the entire range of drive requirements. This results in a substantial reduction of both belt and sheave inventories.

The belt cross-section approaches a true "V" as shown. The groove walls of the sheaves provide more equalized support to the tension members since there is more side wall contact area. These factors, plus the tougher, more resilient belt materials, provide V-belts with exceptional transmission capacity.

1. The "3V" belt measures 3/8" across the top and 5/16" in thickness and is available in lengths from 25" through 140".
2. The "5V" belt measures 5/8" across the top and 17/32" in thickness and is available in lengths from 45" through 355".
3. The "8V" belt measures 1" across the top and 7/8" in thickness and is available in lengths from 100" to 500".

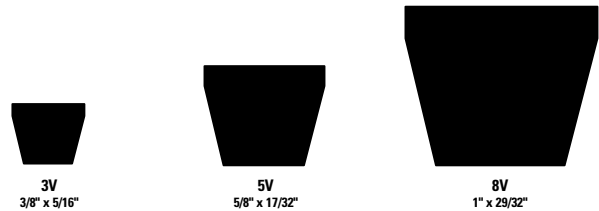
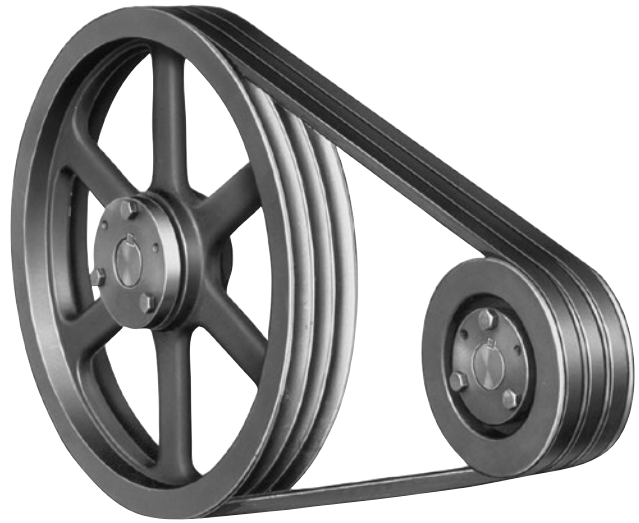

### "358" Gripbelt® Sheaves

Belt Size	Type		Number of Grooves							
			1	2	3	4	5	6	8	
<b>3V</b>	Bushing Type	PD Bore	2.60-24.95 3/8"-2 11/16"	2.60-24.95 3/8"-2 11/16"	2.60-33.45 3/8"-3 3/4"	4.70-33.45 3/8"-3 3/4"	4.70-33.45 1/2"-3 3/4"	4.70-33.45 3/4"-3 3/4"	4.70-33.45 1" - 4 1/4"	
	Finished Bore	PD Bore	2.60-3.30 5/8-7/8	2.60-3.30 3/4-1 1/8	2.60-3.30 7/8-1 1/8	2.60-3.30 7/8-1 3/8				
<b>5V</b>	Bushing Type	PD Bore	4.3-27.90 1/2-2 7/16	4.3-27.90 1/2-3 3/4	4.3-49.90 1/2-5	4.3-49.90 1/2-5	4.3-49.90 3/4-5	7.90-49.90 1-5	7.90-49.90 1-5	
<b>8V</b>	Bushing Type	PD Bore				12.3-63.8 1 11/16-5	12.3-63.8 1 11/16-5	12.3-63.8 1 7/8-7 7/16	12.3-63.8 1 7/8-7 7/16	

Classical and "358" Gripbelt Sheaves are available with either Browning Split Taper® or Q-D® bushings.

## 3V FINISHED BORE "358" GRIPBELT® SHEAVES

**Table No.1 Specifications - Stock "3V" Sheaves**

DIAMETERS (in.)			Part No.	Dimensions (in.)	Stock Bores Marked "X" (in.)							Wt. Lbs.
Pitch "3V" Belts	Outside	Inside		O.L.	C	5/8	3/4	7/8	1	1 1/8	1 3/8	
<b>1 Groove</b>												
2.60	2.65	-	1F3V26	1 7/64	11/64	X	X	-	-	-	-	.7
2.75	2.80	-	1F3V28	1 7/64	11/64	X	X	-	-	-	-	.8
2.95	300	-	1F3V30	1 7/64	11/64	-	X	X	-	-	-	.8
3.10	3.15	-	1F3V31	1 7/64	11/64	-	-	X	-	-	-	.8
3.30	3.35	-	1F3V33	1 7/64	11/64	-	-	X	-	-	-	1.0
<b>2 Grooves</b>												
2.60	2.65	-	2F3V26	1 9/16	3/16	-	X	X	X	-	-	1.3
2.75	2.80	-	2F3V28	1 9/16	3/16	-	X	X	X	-	-	1.4
2.95	300	-	2F3V30	1 9/16	3/16	-	-	X	X	-	-	1.4
3.10	3.15	-	2F3V31	1 9/16	3/16	-	-	X	X	X	-	1.0
3.30	3.35	-	2F3V33	1 9/16	3/16	-	-	X	X	X	-	1.9
<b>3 Grooves</b>												
2.60	2.65	-	3F3V26	1 31/32	1/4	-	-	X	X	X	-	1.5
2.75	2.80	-	3F3V28	1 31/32	1/4	-	-	X	X	X	-	1.7
2.95	300	-	3F3V30	1 31/32	1/4	-	-	-	X	X	-	1.9
3.10	3.15	-	3F3V31	1 31/32	1/4	-	-	-	X	X	-	2.1
3.30	3.35	-	3F3V33	1 31/32	1/4	-	-	-	X	X	-	2.5
<b>4 Grooves</b>												
2.60	2.65	-	4F3V26	2 3/8	1/4	-	-	X	X	X	-	1.9
2.75	2.80	-	4F3V28	2 3/8	1/4	-	-	X	X	X	-	2.4
2.90	3.00	-	4F3V30	2 3/8	1/4	-	-	-	X	X	X	2.5
3.10	3.15	-	4F3V31	2 3/8	1/4	-	-	-	X	X	X	2.8
3.30	3.35	-	4F3V33	2 3/8	1/4	-	-	-	X	X	X	3.4



- 1 - 8 grooves
- 2.65" - 33.50" O.D.
- 1/2" - 3 3/4" bore range
- Machined from fine grain cast iron
- Precision balanced
- Easy on - easy off

"358" Drives can reduce overall dimensions by as much as 40% and drive weight up to 25%. Material savings reflects in lower drive cost.

**Table No.2 Standard Keyseats**

Bore Range (in.)	Keyseat (in.)
5/8 - 7/8	3/16 x 3/32
1 - 1 1/8	1/4 X 1/8

### Browning® SplitTaper® Bushings

- Keyed to shaft and hub. External key provides positive drive with no torque on the cap screws
- Highest torque carrying capacity in the Browning bushing product line
- Double split barrel assures true concentricity
- Inch, metric and spline bores available from stock

For additional product information, visit [www.regalrexnord.com/Browning](http://www.regalrexnord.com/Browning)

## 3V GRIPBELT® SHEAVES WITH BROWNING® SPLIT TAPER® BUSHINGS

**Table No.1 Specifications - Stock "3V" Sheaves**

DIAMETERS (in.)			Part Number		Dimensions (in.)	Wt. Incl. Bush.
Pitch "3V" Belts	Outside	Inside	Sheave	Bushing	OL	
<b>1 Groove, Face Width = 11/16"</b>						
2.60	2.65	-	1G3V26	G	1 5/16	.6
2.75	2.80	-	1G3V28	G	1 5/16	.7
2.95	3.00	-	1G3V30	G	1 5/16	.9
3.10	3.15	-	1H3V31	H	1 7/16	.8
3.30	3.35	-	1H3V33	H	1 7/16	.9
3.60	3.65	-	1H3V36	H	1 1/2	1.4
3.60	3.65	-	1P3V36	P1	2 3/16	2.0
4.07	4.12	-	1H3V41	H	1 1/2	1.9
4.07	4.12	-	1P3V41	P1	2 3/16	2.6
4.45	4.50	-	1H3V45	H	1 1/2	2.2
4.45	4.50	-	1P3V45	P1	2 3/16	3.0
4.70	4.75	-	1H3V47	H	1 1/2	2.4
4.70	4.75	-	1P3V47	P1	2 3/16	3.5
4.95	5.00	-	1H3V50	H	1 1/2	2.6
4.95	5.00	-	1P3V50	P1	2 3/16	3.8
5.25	5.30	-	1H3V53	H	1 1/2	2.5
5.25	5.30	-	1P3V53	P1	2 3/16	4.2
5.55	5.60	-	1H3V56	H	1 1/2	2.6
5.55	5.60	-	1P3V56	P1	2 3/16	4.6
5.95	6.00	-	1H3V60	H	1 1/2	2.9
5.95	6.00	-	1P3V60	P1	2 3/16	5.3
6.45	6.50	5 1/4	1P3V65	P1	2 3/16	5.5
6.85	6.90	5 5/8	1P3V69	P1	2 3/16	4.9
7.95	8.00	6 1/2	1P3V80	P1	2 3/16	6.5
10.55	10.60	9 3/8	1P3V106	P1	2 3/16	7.8
13.95	14.00	12 3/4	1Q3V140	Q1	2 25/32	18.1
18.95	19.00	17 3/4	1Q3V190	Q1	2 25/32	26.3
24.95	25.00	23 5/8	1Q3V250	Q1	2 25/32	38.3



- 1 - 8 grooves
- 2.65" - 33.50" O.D.
- 1/2" - 3 3/4" bore range
- Machined from fine grain cast iron
- Precision balanced
- Easy on - easy off

**Table No.2 Standard Keyseats (in.)**

Bore Range	Keyseat	Bore Range	Keyseat
3/8-7/16	None	1 7/16-1 3/4	3/8 x 3/16
1/2-9/16	1/8 x 1/16	1 13/16-2 1/4	1/2 x 1/4
5/8-7/8	3/16 x 3/32	2 5/16-2 3/4	5/8 x 5/16
15/16-1 1/4	1/4 x 1/8	2 13/16-3 1/4	3/4 x 3/8
1 5/16-1 3/8	5/16 x 5/32	3 3/8-3 3/4	7/8 x 7/16

1 3/8" bore bushings also available with 3/8" x 3/16" keyseat.

**Table No.3 Bore Range**

Bushing	Bore Range (in.)
G	3/8-1
H	3/8-1 1/2
P1	1/2-1 3/4
Q1	3/4-2 11/16
R1	1 1/8-3 3/4

### Browning Split Taper Bushings

- Keyed to shaft and hub.  
External key provides positive drive with no torque on the cap screws
- Highest torque carrying capacity in the Browning bushing product line
- Double split barrel assures true concentricity
- Inch, metric and spline bores available from stock

## 3V GRIPBELT® SHEAVES WITH BROWNING® SPLIT TAPER® BUSHINGS

**Table No.1 Specifications - Stock "3V" Sheaves**

DIAMETERS (in.)			Part Number		Dimensions (in.)		Wt. Less Bush.
Pitch "3V" Belts	Outside	Inside	Sheave	Bushing	OL		
<b>2 Grooves, Face Width = 1 3/32"</b>							
2.60	2.65	-	2G3V26	G	1 19/32	.8	
2.75	2.80	-	2G3V28	G	1 19/32	.9	
2.95	3.00	-	2G3V30	G	1 19/32	1.3	
3.10	3.15	2	2H3V31	H	1 19/32	.9	
3.30	3.35	2	2H3V33	H	1 19/32	1.3	
3.60	3.65	-	2H3V36	H	1 1/2	1.6	
3.60	3.65	-	2P3V36	P1	2 3/16	2.0	
4.07	4.12	-	2H3V41	H	1 1/2	2.3	
4.07	4.12	-	2P3V41	P1	2 3/16	2.8	
4.45	4.50	-	2H3V45	H	1 1/2	2.8	
4.45	4.50	-	2P3V45	P1	2 3/16	3.5	
4.70	4.75	-	2H3V47	H	1 1/2	3.1	
4.70	4.75	-	2P3V47	P1	2 3/16	4.0	
4.95	5.00	-	2H3V50	H	1 1/2	3.4	
4.95	5.00	-	2P3V50	P1	2 3/16	4.6	
5.25	5.30	-	2H3V53	H	1 1/2	3.7	
5.25	5.30	-	2P3V53	P1	2 3/16	5.6	
5.55	5.60	-	2H3V56	H	1 1/2	3.1	
5.55	5.60	-	2P3V56	P1	2 3/16	6.0	
5.95	6.00	-	2H3V60	H	1 1/2	3.6	
5.95	6.00	-	2P3V60	P1	2 3/16	6.8	
6.45	6.50	5 1/4	2Q3V65	Q1	2 25/32	8.3	
6.85	6.90	5 5/8	2Q3V69	Q1	2 25/32	9.8	
7.95	8.00	6 1/2	2Q3V80	Q1	2 25/32	10.8	
10.55	10.60	9 3/8	2Q3V106	Q1	2 25/32	13.5	
13.95	14.00	12 3/4	2Q3V140	Q1	2 25/32	22.5	
18.95	19.00	17 3/4	2Q3V190	Q1	2 25/32	28.9	
24.95	25.00	23 5/8	2Q3V250	Q1	2 25/32	43.5	
<b>3 Grooves, Face Width = 1 1/2"</b>							
2.60	2.65	-	3G3V26	G	2	1.1	
2.75	2.80	-	3G3V28	G	2	1.6	
2.95	3.00	-	3G3V30	G	2	1.8	
3.10	3.15	-	3H3V31	H	2	1.4	
3.30	3.35	-	3H3V33	H	2	1.8	
3.60	3.65	2 3/16	3P3V36	P1	2 3/8	2.5	
4.07	4.12	2 9/16	3P3V41	P1	2 3/8	3.0	
4.45	4.5	3 5/16	3P3V45	P1	2 3/16	3.9	
4.70	4.75	3 1/2	3P3V47	P1	2 3/16	4.4	
4.95	5.00	3 13/16	3P3V50	P1	2 3/16	4.9	
5.25	5.30	4 1/8	3P3V53	P1	2 3/16	5.9	
5.55	5.60	4 3/8	3P3V56	P1	2 3/16	7.5	
5.95	6.00	4 13/16	3P3V60	P1	2 3/16	8.0	
6.45	6.50	5 1/4	3Q3V65	Q1	2 25/32	9.9	
6.85	6.90	5 5/8	3Q3V69	Q1	2 25/32	11.3	
7.95	8.00	6 1/2	3Q3V80	Q1	2 25/32	11.9	
10.55	10.60	9 3/8	3Q3V106	Q1	2 25/32	15.1	
13.95	14.00	12 3/4	3Q3V140	Q1	2 25/32	24.5	
18.95	19.00	17 3/4	3R3V190	R1	3 5/32	35.1	
24.95	25.00	23 5/8	3R3V250	R1	3 5/32	55.0	
33.45	33.50	32 1/4	3R3V335	R1	3 5/32	80.0	
<b>4 Grooves, Face Width = 1 29/32"</b>							
2.60	2.65	1 3/8	4G3V26	G	2 13/32	1.4	
2.75	2.80	1 3/8	4G3V28	G	2 13/32	1.8	
2.95	3.00	1 3/8	4G3V30	G	2 13/32	2.1	
3.10	3.15	1 3/4	4H3V31	H	2 13/32	1.8	
3.30	3.35	2	4H3V33	H	2 13/32	2.3	
3.60	3.65	2 3/16	4P3V36	P1	2 25/32	2.8	
4.07	4.12	2 9/16	4P3V41	P1	2 25/32	3.7	
4.45	4.50	3 5/16	4P3V45	P1	2 3/16	4.4	
4.70	4.75	3 1/2	4P3V47	P1	2 3/16	5.1	
4.95	5.00	3 13/16	4P3V50	P1	2 3/16	5.8	
5.25	5.30	4 1/8	4P3V53	P1	2 3/16	6.5	
5.55	5.60	4 3/8	4P3V56	P1	2 3/16	8.1	
5.95	6.00	4 3/4	4Q3V60	Q1	2 25/32	9.0	
6.45	6.50	5 1/4	4Q3V65	Q1	2 55/64	11.1	
6.85	6.90	5 5/8	4Q3V69	Q1	2 55/64	12.9	
7.95	8.00	6 1/2	4Q3V80	Q1	2 55/64	13.1	
10.55	10.60	9 3/8	4Q3V106	Q1	2 55/64	15.9	
13.95	14.00	12 3/4	4Q3V140	Q1	2 55/64	25.4	
18.95	19.00	17 3/4	4R3V190	R1	3 5/32	37.3	
24.95	25.00	23 5/8	4R3V250	R1	3 5/32	60.0	
33.45	33.50	32 1/4	4R3V335	R1	3 5/32	88.0	



- 1 - 8 grooves
- 2.65" - 33.50" O.D.
- 1/2" - 3 3/4" bore range
- Machined from fine grain cast iron
- Precision balanced
- Easy on - easy off

**Table No.3 Bore Range**

Bushing	Bore Range (in.)
G	3/8 - 1
H	3/8 - 1 1/2
P1	1/2 - 1 3/4
Q1	3/4 - 2 11/16
R1	1 1/8 - 3 3/4

- Browning Split Taper Bushings
- Keyed to shaft and hub. External key provides positive drive with no torque on the cap screws
- Highest torque carrying capacity in the Browning bushing product line
- Double split barrel assures true concentricity
- Inch, metric and spline bores available from stock

### 3V GRIPBELT® SHEAVES WITH BROWNING® SPLIT TAPER® BUSHINGS

**Table No.1 Specifications - Stock "3V" Sheaves**

DIAMETERS (in.)			Part Number		Dimensions (in.)	Wt. Less Bush.
Pitch "3V" Belts	Outside	Inside	Sheave	Bushing	OL	
<b>5 Grooves, Face Width = 2 5/16"</b>						
4.70	4.75	3 1/2	5P3V47	P1	2 9/16	5.6
4.95	5.00	3 13/16	5P3V50	P1	2 9/16	6.0
5.25	5.30	4 1/8	5P3V53	P1	2 9/16	7.1
5.55	5.60	4 3/8	5P3V56	P1	2 9/16	8.1
5.95	6.00	4 3/4	5Q3V60	Q1	2 25/32	9.5
6.45	6.50	5 1/4	5Q3V65	Q1	3 1/16	11.6
6.85	6.90	5 5/8	5Q3V69	Q1	3 1/16	13.9
7.95	8.00	6 1/2	5Q3V80	Q1	3 1/16	14.3
10.55	10.60	9 3/8	5Q3V106	Q1	3 1/16	17.5
13.95	14.00	12 3/4	5Q3V140	Q1	3 1/16	27.5
18.95	19.00	17 3/4	5R3V190	R1	3 5/16	40.9
24.95	25.00	23 5/8	5R3V250	R1	3 5/16	64.0
33.45	33.50	32 1/4	5R3V335	R1	3 5/16	92.0
<b>6 Grooves, Face Width = 2 23/32"</b>						
4.70	4.75	3 1/2	6Q3V47	Q1	3 3/4	5.6
4.95	5.00	3 13/16	6Q3V50	Q1	3 3/4	6.1
5.25	5.30	4 1/8	6Q3V53	Q1	3 3/4	7.3
5.55	5.60	4 1/4	6Q3V56	Q1	3	8.8
5.95	6.00	4 3/4	6Q3V60	Q1	3	10.1
6.45	6.50	5 1/4	6Q3V65	Q1	3 17/64	12.9
6.85	6.90	5 5/8	6Q3V69	Q1	3 17/64	14.4
7.95	8.00	6 1/2	6Q3V80	Q1	3 17/64	16.1
10.55	10.60	9 3/8	6R3V106	R1	3 33/64	22.4
13.95	14.00	12 3/4	6R3V140	R1	3 33/64	32.1
18.95	19.00	17 3/4	6R3V190	R1	3 33/64	42.8
24.95	25.00	23 5/8	6R3V250	R1	3 33/64	64.0
33.45	33.50	32 1/4	6R3V335	R1	3 33/64	99.0
<b>8 Grooves, Face Width = 3 17/32"</b>						
4.70	4.75	3 1/2	8Q3V47	Q2	4 9/16	7.3
4.95	5.00	3 13/16	8Q3V50	Q2	4 9/16	8.6
5.25	5.30	4 1/8	8Q3V53	Q2	4 9/16	10.3
5.55	5.60	4 1/4	8Q3V56	Q2	3 25/32	12.3
5.95	6.00	4 3/4	8Q3V60	Q2	3 25/32	15.1
6.45	6.50	5 1/4	8Q3V65	Q2	4 11/64	18.3
6.85	6.90	5 5/8	8Q3V69	Q2	4 11/64	21.4
7.95	8.00	6 1/2	8R3V80	R1	3 59/64	23.2
10.55	10.60	9 3/8	8R3V106	R1	3 59/64	24.5
13.95	14.00	12 3/4	8R3V140	R1	3 59/64	39.0
18.95	19.00	17 3/4	8R3V190	R1	3 59/64	49.0
24.95	25.00	23 5/8	8R3V250	R1	3 59/64	76.0
33.45	33.50	32 1/4	8S3V335	S1	4 55/64	126

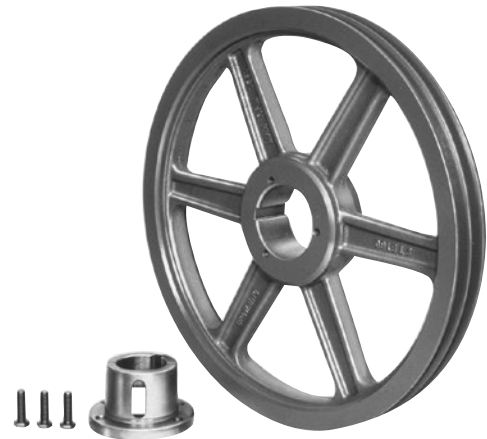

- 1 - 8 grooves
- 2.65" - 33.50" O.D.
- 1/2" - 3 3/4" bore range
- Machined from fine grain cast iron
- Precision balanced
- Easy on - easy off

**Table No.2 Standard Keyseats**

Bore Range (in.)	Keyseat (in.)
1/2-9/16	1/8 x 1/16
5/8-7/8	3/16 x 3/32
15/16-1 1/4	1/4 x 1/8
1 5/16-1 3/8	5/16 x 5/32
1 7/16-1 3/4	3/8 x 3/16
1 13/16-2 1/4	1/2 x 1/4
2 5/16-2 3/4	5/8 x 5/16
2 13/16-3 1/4	3/4 x 3/8
3 3/8-3 3/4	7/8 x 7/16
3 7/8-4 1/4	1 x 1/2

1 3/8" bore bushings also available with 3/8" x 3/16" keyseat.

**Table No.3 Bore Range**

Bushing No.	Bore Range (in.)
P1	1/2-1 3/4
Q1	3/4-2 11/16
R1	1 1/8-3 3/4
S1	1 11/16-4 1/4

**Browning Split Taper Bushings**

- Keyed to shaft and hub. External key provides positive drive with no torque on the cap screws
- Highest torque carrying capacity in the Browning bushing product line
- Double split barrel assures true concentricity
- Inch, metric and spline bores available from stock

## 5V GRIPBELT® SHEAVES WITH BROWNING® SPLIT TAPER® BUSHINGS

**Table No.1 Specifications - Stock "5V" Sheaves**

DIAMETERS (in.)			PART NUMBER		DIMENSIONS (in.)		Wt. Less Bush.
Pitch 5V Belts	Outside	Inside	Sheave	Bushing	O.L.		
<b>2 Grooves, Face Width = 1 1/16"</b>							
▲4.30	4.40	3 3/16	2P5V44	P1	2 3/16		3.8
▲4.50	4.60	2 7/8	2Q5V46	Q1	3 7/8		6.6
▲4.80	4.90	3 1/8	2Q5V49	Q1	3 5/16		6.2
▲5.10	5.20	-	2Q5V52	Q1	2 25/32		5.6
▲5.40	5.50	-	2Q5V55	Q1	2 25/32		6.6
▲5.80	5.90	-	2Q5V59	Q1	2 25/32		7.6
▲6.20	6.30	-	2Q5V63	Q1	2 25/32		9.4
▲6.60	6.7	-	2Q5V67	Q1	2 25/32		11.0
7.00	7.10	-	2Q5V71	Q1	2 25/32		12.3
7.40	7.50	-	2Q5V75	Q1	2 25/32		14.1
7.90	8.00	6 1/4	2Q5V80	Q1	2 25/32		11.6
8.40	8.50	6 3/4	2Q5V85	Q1	2 25/32		12.9
8.90	9.00	7 1/4	2Q5V90	Q1	2 25/32		16.3
9.15	9.25	7 3/8	2Q5V92	Q1	2 25/32		15.1
9.65	9.75	7 7/8	2Q5V97	Q1	2 25/32		16.1
10.20	10.30	8 7/16	2Q5V103	Q1	2 25/32		18.8
10.80	10.90	9	2Q5V109	Q1	2 25/32		19.3
11.70	11.80	10	2Q5V118	Q1	2 25/32		21.4
12.40	12.50	10 3/4	2Q5V125	Q1	2 25/32		23.8
13.10	13.20	11 7/16	2Q5V132	Q1	2 25/32		25.5
13.90	14.00	12 1/4	2R5V140	R1	3 5/32		27.6
14.90	15.00	13 1/4	2R5V150	R1	3 5/32		30.9
15.90	16.00	14 1/4	2R5V160	R1	3 5/32		33.3
21.10	21.20	19 3/8	2R5V212	R1	3 5/32		47.5
27.90	28.00	26 1/4	2R5V280	R1	3 5/32		71.0
<b>3 Grooves, Face Width = 2 3/8"</b>							
▲4.30	4.40	3 3/16	3P5V44	P1	2 23/32		3.1
▲4.50	4.60	2 7/8	3Q5V46	Q1	4 3/4		7.6
▲4.80	4.90	3 1/8	3Q5V49	Q1	3 13/32		7.3
▲5.10	5.20	-	3Q5V52	Q1	3 13/32		5.8
▲5.40	5.50	-	3Q5V55	Q1	3 13/32		7.5
▲5.80	5.90	-	3Q5V59	Q1	2 31/32		8.6
▲6.20	6.30	-	3Q5V63	Q1	2 31/32		10.3
▲6.60	6.7	-	3Q5V67	Q1	2 31/32		12.0
7.00	7.10	-	3Q5V71	Q1	2 31/32		13.9
7.40	7.50	-	3Q5V75	Q1	2 31/32		16.0
7.90	8.00	6 1/4"	3R5V80	R1	3 11/32		17.2
8.40	8.50	6 3/4	3R5V85	R1	3 11/32		20.5
8.90	9.00	7 1/4	3R5V90	R1	3 11/32		22.2
9.15	9.25	7 3/8	3R5V92	R1	3 11/32		24.1
9.65	9.75	7 7/8	3R5V97	R1	3 11/32		24.8
10.20	10.30	8 7/16	3R5V103	R1	3 11/32		26.4
10.80	10.90	9	3R5V109	R1	3 11/32		28.0
11.70	11.80	10	3R5V118	R1	3 11/32		31.9
12.40	12.50	10 3/4	3R5V125	R1	3 11/32		35.1
13.10	13.20	11 7/16	3R5V132	R1	3 11/32		29.0
13.90	14.00	12 1/4	3R5V140	R1	3 11/32		32.3
14.90	15.00	13 1/4	3R5V150	R1	3 11/32		35.0
15.90	16.00	14 1/4	3R5V160	R1	3 11/32		38.7
21.10	21.20	19 3/8	3R5V212	R1	3 11/32		52.0
27.90	28.00	26 1/4	3R5V280	R1	3 11/32		80.0
37.40	37.50	35 3/4	3S5V375	S1	4 3/4		147
49.90	50.00	48 1/4	3U5V500	U0	5 13/32		216

▲ For use only with 358 Gripnotch® Belts.



5V  
5/8" x 17/32"

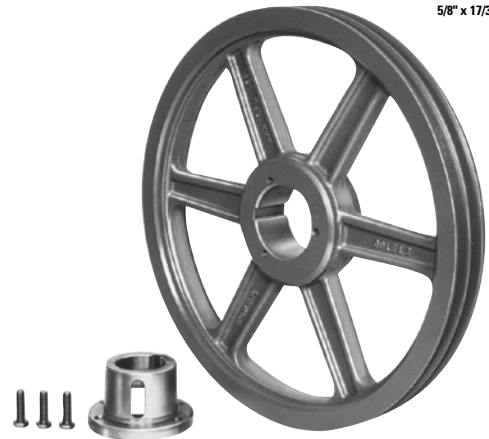

- 2 - 8 grooves
- 4.40" - 50.00" O.D.
- 1/2" - 5 1/2" bore range
- Machined from fine grain cast iron
- Precision balanced
- Easy on - easy off

**Table No.2 Standard Keyseats**

Bore Range (in.)	Keyseat (in.)
1/2-9/16	1/8 x 1/16
5/8-7/8	3/16 x 3/32
15/16-1 1/4	1/4 x 1/8
1 5/16-1 3/8	5/16 x 5/32
1 7/16-1 3/4	3/8 x 3/16
1 13/16-2 1/4	1/2 x 1/4
2 5/16-2 3/4	5/8 x 5/16
2 13/16-3 1/4	3/4 x 3/8
3 3/8-3 3/4	7/8 x 7/16
3 7/8-4 1/4	1 x 1/2

1 3/8" bore bushings also available with 3/8" x 3/16" keyseat.

**Table No.3 Bore Range**

Bushing No.	Bore Range (in.)
P1	1/2-1 3/4
Q1	3/4-2 11/16
R1	1 1/8-3 3/4
S1	1 11/16-4 1/4

**Browning Split Taper Bushings**

- Keyed to shaft and hub. External key provides positive drive with no torque on the cap screws
- Highest torque carrying capacity in the Browning bushing product line
- Double split barrel assures true concentricity
- Inch, metric and spline bores available from stock

### 5V GRIPBELT® SHEAVES WITH BROWNING® SPLIT TAPER® BUSHINGS

Table No.1 Specifications - Stock "5V" Sheaves

DIAMETERS (in.)			Part Number		Dimensions (in.)	Wt. Less Bush.
Pitch 3V Belts	Outside	Inside	Sheave	Bushing	O.L.	
<b>4 Grooves, Face Width = 3 1/16"</b>						
▲4.30	4.40	3	4P5V44	P1	3 3/16	3.2
▲4.50	4.60	2 7/8	4Q5V46	Q2	5 1/4	8.6
▲4.80	4.90	3 1/8	4Q5V49	Q1	4 3/32	8.5
▲5.10	5.20	3 1/2	4Q5V52	Q1	4 3/32	7.8
▲5.40	5.50	3 3/4	4Q5V55	Q1	4 3/32	8.3
▲5.80	5.90	4 3/16	4Q5V59	Q1	4 3/32	10.1
▲6.20	6.30	4 9/16	4Q5V63	Q1	4 3/32	11.8
▲6.60	6.70	5	4Q5V67	Q1	4 3/32	13.6
7.00	7.10	5 3/8	4Q5V71	Q1	3 11/32	15.9
7.40	7.50	5 3/4	4Q5V75	Q1	3 11/32	18.4
7.90	8.00	6 1/4	4R5V80	R1	3 11/16	19.4
8.40	8.50	6 3/4	4R5V85	R1	3 11/16	22.8
8.90	9.00	7 1/4	4R5V90	R1	3 11/16	24.5
9.15	9.25	7 3/8	4R5V92	R1	3 11/16	26.6
9.65	9.75	7 7/8	4R5V97	R1	3 11/16	28.0
10.20	10.30	8 7/16	4R5V103	R1	3 11/16	30.8
10.80	10.90	9	4R5V109	R1	3 11/16	31.7
11.70	11.80	10	4R5V118	R1	3 11/16	35.3
12.40	12.50	10 3/4	4R5V125	R1	3 11/16	37.9
13.10	13.20	11 7/16	4R5V132	R1	3 11/16	33.3
13.90	14.00	12 1/4	4R5V140	R1	3 11/16	36.5
14.90	15.00	13 1/4	4R5V150	R1	3 11/16	40.9
15.90	16.00	14 1/4	4R5V160	R1	3 11/16	43.3
21.10	21.20	19 3/8	4R5V212	R1	3 11/16	59.0
27.90	28.00	26 1/4	4S5V280	S1	4 3/4	135
37.40	37.50	35 3/4	4S5V375	S1	4 3/4	157
49.90	50.00	48 1/4	4U5V500	U0	5 13/32	239

**5 Grooves, Face Width = 3 3/4"**

▲4.30	4.40	3	5P5V44	P1	3 3/16	3.2
▲4.50	4.60	2 7/8	5Q5V46	Q2	5 1/4	8.6
▲4.80	4.90	3 1/8	5Q5V49	Q1	4 3/32	8.5
▲5.10	5.20	3 1/2	5Q5V52	Q1	4 3/32	7.8
▲5.40	5.50	3 3/4	5Q5V55	Q1	4 3/32	8.3
▲5.80	5.90	4 3/16	5Q5V59	Q1	4 3/32	10.1
▲6.20	6.30	4 9/16	5Q5V63	Q1	4 3/32	11.8
▲6.60	6.70	5	5Q5V67	Q1	4 3/32	13.6
7.00	7.10	5 3/8	5Q5V71	Q1	3 11/32	15.9
7.40	7.50	5 3/4	5Q5V75	Q1	3 11/32	18.4
7.90	8.00	6 1/4	5R5V80	R1	3 11/16	19.4
8.40	8.50	6 3/4	5R5V85	R1	3 11/16	22.8
8.90	9.00	7 1/4	5R5V90	R1	3 11/16	24.5
9.15	9.25	7 3/8	5R5V92	R1	3 11/16	26.6
9.65	9.75	7 7/8	5R5V97	R1	3 11/16	28.0
10.20	10.30	8 7/16	5R5V103	R1	3 11/16	30.8
10.80	10.90	9	5R5V109	R1	3 11/16	31.7
11.70	11.80	10	5R5V118	R1	3 11/16	35.3
12.40	12.50	10 3/4	5R5V125	R1	3 11/16	37.9
13.10	13.20	11 7/16	5R5V132	R1	3 11/16	33.3
13.90	14.00	12 1/4	5R5V140	R1	3 11/16	36.5
14.90	15.00	13 1/4	5R5V150	R1	3 11/16	40.9
15.90	16.00	14 1/4	5R5V160	R1	3 11/16	43.3
21.10	21.20	19 3/8	5S5V212	R1	3 11/16	59.0
27.90	28.00	26 1/4	5S5V280	S1	4 3/4	135
37.40	37.50	35 3/4	5U5V375	S1	4 3/4	157
49.90	50.00	48 1/4	5U5V500	U0	5 13/32	239

▲ For use only with 358 Gripnotch® Belts.



5V  
5/8" x 17/32"

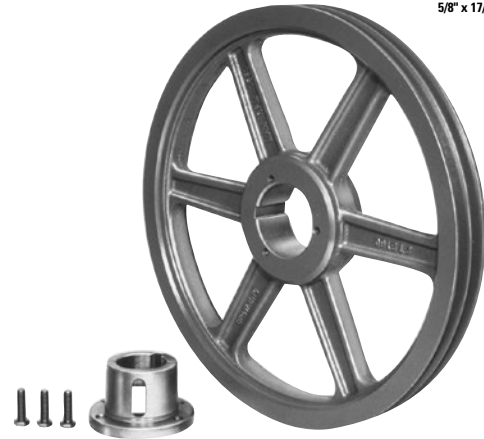

- 2 - 8 grooves
- 4.40" - 50.00" O.D.
- 1/2" - 5 1/2" bore range
- Machined from fine grain cast iron
- Precision balanced
- Easy on - easy off

Table No.2 Standard Keyseats

Bore Range (in.)	Keyseat (in.)
1/2-9/16	1/8 x 1/16
5/8-7/8	3/16 x 3/32
15/16-1 1/4	1/4 x 1/8
1 5/16-1 3/8	5/16 x 5/32
1 7/16-1 3/4	3/8 x 3/16
1 13/16-2 1/4	1/2 x 1/4
2 5/16-2 3/4	5/8 x 5/16
2 13/16-3 1/4	3/4 x 3/8
3 3/8-3 3/4	7/8 x 7/16
3 7/8-4 1/2	1 x 1/2
4 9/16-5 1/2	1 1/4 x 5/8

1 3/8" bore bushings also available with 3/8" x 3/16" keyseat.

Table No.3 Bore Range

Bushing No.	Bore Range (in.)
P1	1/2-1 3/4
Q1	3/4-2 11/16
Q2	1-2 5/8
R1	1 1/8-3 3/4
S1	1 11/16-4 1/4
U0	2 3/8-5 1/2
U1	2 3/8-5 1/2

**Browning Split Taper Bushings**

- Keyed to shaft and hub. External key provides positive drive with no torque on the cap screws
- Highest torque carrying capacity in the Browning bushing product line
- Double split barrel assures true concentricity
- Inch, metric and spline bores available from stock

## 5V GRIPBELT® SHEAVES WITH BROWNING® SPLIT TAPER® BUSHINGS

**Table No.1 Specifications - Stock "5V" Sheaves**

DIAMETERS (in.)			Part Number		Dimensions (in.)	Wt. Less Bush.
Pitch "3V" Belts	Outside	Inside	Sheave	Bushing	O.L.	
<b>6 Grooves, Face Width = 4 7/16"</b>						
7.00	7.10	5 3/8	6Q5V71	Q2	4 7/16	23.6
7.40	7.50	5 3/4	6Q5V75	Q2	4 7/16	27.3
7.90	8.00	6 1/4	6R5V80	R1	4 7/16	23.3
8.40	8.50	6 3/4	6R5V85	R1	4 7/16	27.3
8.90	9.00	7 1/4	6R5V90	R1	4 7/16	28.8
9.15	9.25	7 3/8	6R5V92	R1	4 7/16	31.1
9.65	9.75	7 7/8	6R5V97	R1	4 7/16	34.5
10.20	10.30	8 7/16	6R5V103	R1	4 7/16	36.8
10.80	10.90	9	6R5V109	R1	4 7/16	39.6
11.70	11.80	10	6R5V118	R1	4 7/16	42.5
12.40	12.50	10 3/4	6S5V125	S1	5 5/16	65.0
13.10	13.20	11 7/16	6S5V132	S1	5 5/16	71.0
13.90	14.00	12 1/4	6S5V140	S1	5 5/16	70.0
14.90	15.00	13 1/4	6S5V150	S1	5 5/16	69.0
15.90	16.00	14 1/4	6S5V160	S1	5 5/16	79.0
21.10	21.20	19 3/8	6S5V212	S1	5 5/16	97.0
24.90	25.00	23 1/4	6S5V250	S1	5 5/16	113
27.90	28.00	26 1/4	6S5V280	S1	5 5/16	128
37.40	37.50	35 3/4	6U5V375	U0	5 3/4	206
49.90	50.00	48 1/4	6U5V500	U0	5 3/4	271
<b>8 Grooves, Face Width = 5 13/16"</b>						
7.00	7.10	5 3/8	8Q5V71	Q2	4 7/16	23.6
7.40	7.50	5 3/4	8Q5V75	Q2	4 7/16	27.3
7.90	8.00	6 1/4	8R5V80	R1	4 7/16	23.3
8.40	8.50	6 3/4	8R5V85	R1	4 7/16	27.3
8.90	9.00	7 1/4	8R5V90	R1	4 7/16	28.8
9.15	9.25	7 3/8	8R5V92	R1	4 7/16	31.1
9.65	9.75	7 7/8	8R5V97	R1	4 7/16	34.5
10.20	10.30	8 7/16	8R5V103	R1	4 7/16	36.8
10.80	10.90	9	8R5V109	R1	4 7/16	39.6
11.70	11.80	10	8R5V118	R1	4 7/16	42.5
12.40	12.50	10 3/4	8S5V125	S1	5 5/16	65.0
13.10	13.20	11 7/16	8S5V132	S1	5 5/16	71.0
13.90	14.00	12 1/4	8S5V140	S1	5 5/16	70.0
14.90	15.00	13 1/4	8S5V150	S1	5 5/16	69.0
15.90	16.00	14 1/4	8S5V160	S1	5 5/16	79.0
21.10	21.20	19 3/8	8S5V212	S1	5 5/16	97.0
24.90	25.00	23 1/4	8S5V250	S1	5 5/16	113
27.90	28.00	26 1/4	8S5V280	S1	5 5/16	128
37.40	37.50	35 3/4	8U5V375	U0	5 3/4	206
49.90	50.00	48 1/4	8U5V500	U0	5 3/4	271



5V  
5/8" x 17/32"

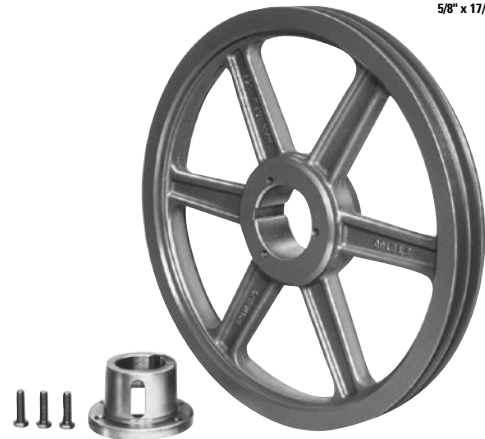

- 2 - 8 grooves
- 4.40" - 50.00" O.D.
- 1/2" - 5 1/2" bore range
- Machined from fine grain cast iron
- Precision balanced
- Easy on - easy off

**Table No.2 Standard Keyseats**

Bore Range (in.)	Keyseat (in.)
1/2-9/16	1/8 x 1/16
5/8-7/8	3/16 x 3/32
15/16-1 1/4	1/4 x 1/8
1 5/16-1 3/8	5/16 x 5/32
1 7/16-1 3/4	3/8 x 3/16
1 13/16-2 1/4	1/2 x 1/4
2 5/16-2 3/4	5/8 x 5/16
2 13/16-3 1/4	3/4 x 3/8
3 3/8-3 3/4	7/8 x 7/16
3 7/8-4 1/2	1 x 1/2
4 9/16-5 1/2	1 1/4 x 5/8

1 3/8" bore bushings also available with 3/8" x 3/16" keyseat.

**Table No.3 Bore Range**

Bushing No.	Bore Range (in.)
P1	1/2-1 3/4
Q1	3/4-2 11/16
Q2	1-2 5/8
R1	1 1/8-3 3/4
S1	1 11/16-4 1/4
U0	2 3/8-5 1/2
U1	2 3/8-5 1/2

**Browning Split Taper Bushings**

- Keyed to shaft and hub. External key provides positive drive with no torque on the cap screws
- Highest torque carrying capacity in the Browning bushing product line
- Double split barrel assures true concentricity
- Inch, metric and spline bores available from stock

### 8V GRIPBELT® SHEAVES WITH BROWNING® SPLIT TAPER® BUSHINGS

**Table No.1 Specifications - Stock "8V" Sheaves**

DIAMETERS (in.)			4 Grooves, Face Width = 4 7/8"			
Pitch "8V" Belts	Outside	Inside	Part Number		Dimensions (in.)	Wt. Less Bush.
			Sheave	Bushing	O.L.	
12.3	12.5	9 1/2	4S8V125	S1	4 7/8	94
13.0	13.2	10 1/4	4S8V132	S1	4 7/8	99
13.8	14.0	11	4S8V140	S1	4 7/8	114
14.8	15.0	12	4S8V150	S1	4 7/8	107
15.8	16.0	13	4S8V160	S1	4 7/8	113
16.8	17.0	14	4S8V170	S1	4 7/8	115
17.8	18.0	15	4S8V180	S1	4 7/8	123
18.8	19.0	16	4S8V190	S1	4 7/8	132
19.8	20.0	17	4S8V200	S1	4 7/8	147
21.0	21.2	18 1/4	4S8V212	S1	4 7/8	159
22.2	22.4	19 3/8	4U8V224	U0	5 31/32	159
29.8	30.0	27	4U8V300	U0	5 31/32	218
39.8	40.0	37	4U8V400	U0	5 31/32	296
47.8	48.0	45	4U8V480	U0	5 31/32	405
52.8	53.0	49 3/4	4U8V530	U0	5 31/32	450
57.8	58.0	54 3/4	4U8V580	U0	5 31/32	495
63.8	64.0	60 3/4	4U8V640	U0	5 31/32	520

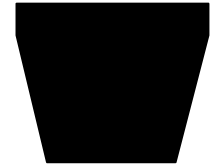

8V  
1" x 29/32"



**Table No.2**

DIAMETERS (in.)			5 Grooves, Face Width = 6"			
Pitch "8V" Belts	Outside	Inside	Part Number		Dimensions (in.)	Wt. Less Bush.
			Sheave	Bushing	O.L.	
12.3	12.5	9 1/2	5S8V125	S1	5	100
13.0	13.2	10 1/4	5S8V132	S1	6	109
13.8	14.0	11	5S8V140	S1	6	127
14.8	15.0	12	5S8V150	S1	6	120
15.8	16.0	13	5S8V160	S1	6	121
16.8	17.0	14	5S8V170	S1	6	133
17.8	18.0	15	5S8V180	S1	6	140
18.8	19.0	16	5S8V190	S1	6	158
19.8	20.0	17	5S8V200	S1	6	166
21.0	21.2	18 1/4	5S8V212	S1	6	174
22.2	22.4	19 3/8	5U8V224	U0	6 17/32	157
29.8	30.0	27	5U8V300	U0	6 17/32	243
39.8	40.0	37	5U8V400	U0	6 17/32	325
47.8	48.0	45	5U8V480	U0	6 17/32	440
52.8	53.0	49 3/4	5U8V530	U0	6 17/32	480
57.8	58.0	54 3/4	5U8V580	U0	6 17/32	525
63.8	64.0	60 3/4	5U8V640	U0	6 17/32	555

- 4 - 8 grooves
- 12.5" - 64.0" O.D.
- 1 11/16" - 7 7/16" bore range
- Machined from fine grain cast iron
- Precision balanced
- Easy on - easy off

**Table No.3 Standard Keyseats**

Bore Range (in.)	Keyseat (in.)
1 7/8 - 2 1/4	1/2 x 1/4
2 5/16 - 2 3/4	5/8 x 5/16
2 13/16 - 3 1/4	3/4 x 3/8
3 3/8 - 3 3/4	7/8 x 7/16
3 7/8 - 4 1/2	1 x 1/2
4 9/16 - 5 1/2	1 1/4 x 5/8

**Table No.4 Bore Range**

Bushing No.	Bore Range (in.)
S1	1 11/16 - 4 1/4
U0	2 3/8 - 5 1/2

**Browning Split Taper Bushings**

- Keyed to shaft and hub.  
External key provides positive drive with no torque on the cap screws
- Highest torque carrying capacity in the Browning bushing product line
- Double split barrel assures true concentricity
- Inch, metric and spline bores available from stock

## 8V GRIPBELT® SHEAVES WITH BROWNING® SPLIT TAPER® BUSHINGS

**Table No.1 Specifications - Stock "8V" Sheaves**

DIAMETERS (in.)			6 Grooves, Face Width = 7 1/8"			
Pitch "8V" Belts	Outside	Inside	Part Number		Dimensions (in.)	Wt. Less Bush.
			Sheave	Bushing	O.L.	
12.3	12.5	9 1/2	6S8V125	S1	7 1/8	109
13.0	13.2	10 1/4	6S8V132	S1	7 1/8	119
13.8	14.0	11	6S8V140	S1	7 1/8	135
14.8	15.0	12	6S8V150	S1	7 1/8	129
15.8	16.0	13	6S8V160	S1	7 1/8	133
16.8	17.0	14	6S8V170	S1	7 1/8	147
17.8	18.0	15	6S8V180	S1	7 1/8	154
18.8	19.0	16	6S8V190	S1	7 1/8	167
19.8	20.0	17	6S8V200	S1	7 1/8	178
21.0	21.2	18 1/4	6S8V212	S1	7 1/8	186
22.2	22.4	19 3/8	6U8V224	U0	7 1/8	195
29.8	30.0	27	6U8V300	U0	7 1/8	263
39.8	40.0	37	6U8V400	U0	7 1/8	363
47.8	48.0	45	6U8V480	U0	7 1/8	478
52.8	53.0	49 3/4	6U8V530	U0	7 1/8	510
57.8	58.0	54 3/4	6U8V580	U0	7 1/8	555
63.8	64.0	60 3/4	6U8V640	U0	7 1/8	585

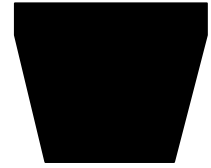

8V  
1" x 29/32"



**Table No.2**

DIAMETERS (in.)			8 Grooves, Face Width = 9 3/8"			
Pitch "8V" Belts	Outside	Inside	Part Number		Dimensions (in.)	Wt. Less Bush.
			Sheave	Bushing	O.L.	
12.3	12.5	9 1/2	8S8V125	S2	9 3/8	140
13.0	13.2	10 1/4	8S8V132	S2	9 3/8	176
13.8	14.0	11	8S8V140	S2	9 3/8	205
14.8	15.0	12	8S8V150	S2	9 3/8	186
15.8	16.0	13	8S8V160	S2	9 3/8	210
16.8	17.0	14	8U8V170	U1	9 3/8	248
17.8	18.0	15	8U8V180	U1	9 3/8	249
18.8	19.0	16	8U8V190	U1	9 3/8	235
19.8	20.0	17	8U8V200	U1	9 3/8	251
21.0	21.2	18 1/4	8U8V212	U1	9 3/8	268
22.2	22.4	19 3/8	8U8V224	U1	9 15/32	253
29.8	30.0	27	8U8V300	U1	9 15/32	358
39.8	40.0	37	8W8V400	W1	10 5/16	567
47.8	48.0	45	8W8V480	W1	10 5/16	715
52.8	53.0	49 3/4	8W8V530	W1	10 5/16	762
57.8	58.0	54 3/4	8W8V580	W1	10 5/16	914
63.8	64.0	60 3/4	8W8V640	W1	10 5/16	970

- 4 - 8 grooves
- 12.5" - 64.0" O.D.
- 1 11/16" - 7 7/16" bore range
- Machined from fine grain cast iron
- Precision balanced
- Easy on - easy off

**Table No.3 Standard Keyseats**

Bore Range (in.)	Keyseat (in.)
1 7/8 - 2 1/4	1/2 x 1/4
2 5/16 - 2 3/4	5/8 x 5/16
2 13/16 - 3 1/4	3/4 x 3/8
3 3/8 - 3 3/4	7/8 x 7/16
3 7/8 - 4 1/2	1 x 1/2
4 9/16 - 5 1/2	1 1/4 X 5/8
5 9/16 - 6 1/2	1 1/2 X 3/4
6 9/16 - 7 7/16	1 3/4 X 3/4

**Table No.4 Bore Range**

Bushing No.	Bore Range (in.)
S1	1 11/16 - 4 1/4
S2	1 7/8 - 4 3/16
U0	2 3/8 - 5 1/2
U1	2 3/8 - 5 1/2
U2	2 7/16 - 5
W1	3 3/8 - 7 7/16

**Browning Split Taper Bushings**

- Keyed to shaft and hub. External key provides positive drive with no torque on the cap screws
- Highest torque carrying capacity in the Browning bushing product line
- Double split barrel assures true concentricity
- Inch, metric and spline bores available from stock

## Q-D® SHEAVES FOR "A" AND "B" BELTS

**Table No.1 Specifications - Stock "B" Sheaves**

Part No.	Bushing	Bore Range (in.)	D.D. (in.)		O.D. (in.)	Wt. Less Bushing
			"B" Belts	"A" Belts		
<b>1 Groove, Face Width = 7/8" (1B34SH - 1B70SDS)</b>						
<b>Face Width = 1" (1B74SDS - 1B200SK)</b>						
1B34SH	SH	1/2 - 1 5/8	3.4	3.0	3.75	2.0
1B36SH	SH	1/2 - 1 5/8	3.6	3.2	3.95	2.2
1B38SH	SH	1/2 - 1 5/8	3.8	3.4	4.15	2.4
1B40SH	SH	1/2 - 1 5/8	4.0	3.6	4.35	2.7
1B42SH	SH	1/2 - 1 5/8	4.2	3.8	4.55	2.9
1B44SH	SH	1/2 - 1 5/8	4.4	4.0	4.75	3.4
1B46SDS	SDS	1/2 - 2	4.6	4.2	4.95	4.0
1B48SDS	SDS	1/2 - 2	4.8	4.4	5.15	4.3
1B50SDS	SDS	1/2 - 2	5.0	4.6	5.35	4.7
1B52SDS	SDS	1/2 - 2	5.2	4.8	5.55	5.0
1B54SDS	SDS	1/2 - 2	5.4	5.0	5.75	5.3
1B56SDS	SDS	1/2 - 2	5.6	5.2	5.95	5.6
1B58SDS	SDS	1/2 - 2	5.8	5.4	6.15	5.9
1B60SDS	SDS	1/2 - 2	6.0	5.6	6.35	6.2
1B62SDS	SDS	1/2 - 2	6.2	5.8	6.55	6.5
1B64SDS	SDS	1/2 - 2	6.4	6.0	6.75	6.8
1B65SDS	SDS	1/2 - 2	6.6	6.2	6.95	7.2
1B68SDS	SDS	1/2 - 2	6.8	6.4	7.15	7.5
1B70SDS	SDS	1/2 - 2	7.0	6.6	7.35	7.8
1B74SDS	SDS	1/2 - 2	7.4	7.0	7.75	8.8
1B80SDS	SDS	1/2 - 2	8.0	7.6	8.35	9.6
1B86SDS	SDS	1/2 - 2	8.6	8.2	8.95	10.0
1B94SDS	SDS	1/2 - 2	9.4	9.0	9.75	10.5
1B110SDS	SDS	1/2 - 2	11.0	10.6	11.35	11.0
1B124SDS	SDS	1/2 - 2	12.4	12.0	12.75	12.0
1B136SDS	SDS	1/2 - 2	13.6	13.2	13.95	14.0
1B154SK	SK	1/2 - 2 5/8	15.4	15.0	15.75	16.0
1B160SK	SK	1/2 - 2 5/8	16.0	15.6	16.35	16.6
1B184SK	SK	1/2 - 2 5/8	18.4	18.0	18.75	18.0
1B200SK	SK	1/2 - 2 5/8	20.0	19.6	20.28	21.4
<b>2 Grooves, Face Width = 1 3/4"</b>						
2B34SH	SH	1/2 - 1 5/8	3.4	3.0	3.75	3.2
2B36SH	SH	1/2 - 1 5/8	3.6	3.2	3.95	3.4
2B38SH	SH	1/2 - 1 5/8	3.8	3.4	4.15	3.9
2B40SH	SH	1/2 - 1 5/8	4.0	3.6	4.35	4.1
2B42SH	SH	1/2 - 1 5/8	4.2	3.8	4.55	4.4
2B44SH	SH	1/2 - 1 5/8	4.4	4.0	4.75	4.6
2B46SDS	SDS	1/2 - 2	4.6	4.2	4.95	5.0
2B48SDS	SDS	1/2 - 2	4.8	4.4	5.15	5.4
2B50SDS	SDS	1/2 - 2	5.0	4.6	5.35	6.0
2B52SDS	SDS	1/2 - 2	5.2	4.8	5.55	6.3
2B54SDS	SDS	1/2 - 2	5.4	5.0	5.75	6.6
2B56SDS	SDS	1/2 - 2	5.6	5.2	5.95	6.9
2B58SDS	SDS	1/2 - 2	5.8	5.4	6.15	7.2
2B60SDS	SDS	1/2 - 2	6.0	5.6	6.35	7.5
2B62SDS	SDS	1/2 - 2	6.2	5.8	6.55	7.8
2B64SDS	SDS	1/2 - 2	6.4	6.0	6.75	8.2
2B66SDS	SDS	1/2 - 2	6.6	6.2	6.95	8.6
2B68SDS	SDS	1/2 - 2	6.8	6.4	7.15	9.0
2B70SK	SK	1/2 - 2 5/8	7.0	6.6	7.35	9.3
2B74SK	SK	1/2 - 2 5/8	7.4	7.0	7.75	10.6



- 1 - 8 grooves
- 3.75" - 38.35" O.D.
- 1/2" - 4 1/2" bore range
- Machined from fine grain cast iron
- Precision balanced
- Easy on - easy off

**Table No.2 Standard Keyseats**

Bore Range (in.)	Keyseat (in.)
1/2 - 9/16	1/8 X 1/16
5/8 - 7/8	3/16 X 3/32
15/16 - 1 1/4	1/4 X 1/8
1 5/16 - 1 3/8	5/16 X 5/32
1 7/16 - 1 3/4	3/8 X 3/16
1 13/16 - 2 1/4	1/2 X 1/4
2 5/16 - 2 3/4	5/8 X 5/16
2 13/16 - 3 1/4	3/4 X 3/8
3 3/8 - 3 3/4	7/8 X 7/16

**Q-D Bushings**

- Can be reverse mounted.
- Setscrew over keyway except JA.
- Stock metric bores - 25 mm - 100 mm.

For optimum sheave selection, see B5V® Stock Sheave Listing on pages 23-27, 31-33.

For additional product information, visit [www.regalrexnord.com/Browning](http://www.regalrexnord.com/Browning)

## Q-D® SHEAVES FOR "A" AND "B" BELTS

**Table No.1 Specifications - Stock "B" Sheaves**

Part No.	Bushing	Bore Range (in.)	D.D. (in.)		O.L. (in.)	Wt. Less Bushing
			"B" Belts	"A" Belts		
<b>2 Grooves (Cont.), Face Width = 1 3/4"</b>						
2B80SK	SK	1/2 - 2 5/8	8.0	7.6	8.35	11.0
2B86SK	SK	1/2 - 2 5/8	8.6	8.2	8.95	11.6
2B94SK	SK	1/2 - 2 5/8	9.4	9.0	9.75	13.0
2B110SK	SK	1/2 - 2 5/8	11.0	10.6	11.35	14.0
2B124SK	SK	1/2 - 2 5/8	12.4	12.0	12.75	18.0
2B136SK	SK	1/2 - 2 5/8	13.6	13.2	13.95	20.0
2B154SK	SK	1/2 - 2 5/8	15.4	15.0	15.75	23.0
2B160SK	SK	1/2 - 2 5/8	16.0	15.6	16.35	24.0
2B184SK	SK	1/2 - 2 5/8	18.4	18.0	18.75	29.0
2B200SF	SF	1/2 - 2 15/16	20.0	4.8	20.35	33.0
2B250SF	SF	1/2 - 2 15/16	25.0	5.0	25.35	41.0
2B300SF	SF	1/2 - 2 15/16	30.0	5.2	30.35	51.0
2B380SF	SF	1/2 - 2 15/16	38.0	5.4	38.35	64.0
<b>3 Grooves, Face Width = 2 1/2"</b>						
3B34SH	SH	1/2 - 1 5/8	3.4	3.0	3.75	434
3B36SH	SH	1/2 - 1 5/8	3.6	3.2	3.95	4.7
3B38SH	SH	1/2 - 1 5/8	3.8	3.4	4.15	5.3
3B40SH	SH	1/2 - 1 5/8	4.0	3.6	4.35	5.6
3B42SH	SH	1/2 - 1 5/8	4.2	3.8	4.55	5.9
3B44SH	SH	1/2 - 1 5/8	4.4	4.0	4.75	6.3
3B46SD	SD	1/2 - 2	4.6	4.2	4.95	6.7
3B48SD	SD	1/2 - 2	4.8	4.4	5.15	7.1
3B50SD	SD	1/2 - 2	5.0	4.6	5.35	7.4
3B52SD	SD	1/2 - 2	5.2	4.8	5.55	7.8
3B54SD	SD	1/2 - 2	5.4	5.0	5.75	8.2
3B56SD	SD	1/2 - 2	5.6	5.2	5.95	8.5
3B58SD	SD	1/2 - 2	5.8	5.4	6.15	8.8
3B60SD	SD	1/2 - 2	6.0	5.6	6.35	9.1
3B62SD	SD	1/2 - 2	6.2	5.8	6.55	9.4
3B64SD	SD	1/2 - 2	6.4	6.0	6.75	9.7
3B66SD	SD	1/2 - 2	6.6	6.2	6.95	10.0
3B68SD	SD	1/2 - 2	6.8	6.4	7.15	10.5
3B70SK	SK	1/2 - 2 5/8	7.0	6.6	7.35	11.0
3B74SK	SK	1/2 - 2 5/8	7.4	7.0	7.75	12.0
3B80SK	SK	1/2 - 2 5/8	8.0	7.6	8.35	12.5
3B86SK	SK	1/2 - 2 5/8	8.6	8.2	8.95	13.0
3B94SK	SK	1/2 - 2 5/8	9.4	9.0	9.75	16.0
3B110SK	SK	1/2 - 2 5/8	11.0	10.6	11.35	19.0
3B124SK	SK	1/2 - 2 5/8	12.4	12.0	12.75	24.0
3B136SK	SK	1/2 - 2 5/8	13.6	13.2	13.95	27.0
3B154SK	SK	1/2 - 2 5/8	15.4	15.0	15.75	30.0
3B160SK	SK	1/2 - 2 5/8	16.0	15.6	16.35	33.0
3B184SK	SK	1/2 - 2 5/8	18.4	18.0	18.75	38.0
3B200SF	SF	1/2 - 2 15/16	20.0	19.6	20.35	43.0
3B250SF	SF	1/2 - 2 15/16	25.0	24.6	25.35	54.0
3B300SF	SF	1/2 - 2 15/16	30.0	29.6	30.35	67.0
3B380E	E	7/8 - 3 1/2	38.0	37.6	38.35	90.0



- 1 - 8 grooves
- 3.75" - 38.035" O.D.
- 1/2" - 4 1/2" bore range
- Machined from fine grain cast iron
- Precision balanced
- Easy on - easy off

For optimum sheave selection, see B5V® Stock Sheave Listing on pages 23-27, 31-33.

**Table No.2 Standard Keyseats**

Bore Range (in.)	Keyseat (in.)
1/2 - 9/16	1/8 X 1/16
5/8 - 7/8	3/16 X 3/32
15/16 - 1 1/4	1/4 X 1/8
1 5/16 - 1 1/4	5/16 X 5/32
1 7/16 - 1 3/8	3/8 X 3/16
1 13/16 - 2 1/4	1/2 X 1/4
2 5/16 - 2 3/4	5/8 X 5/16
2 13/16 - 3 1/4	3/4 X 3/8
3 3/8 - 3 3/4	7/8 X 7/16
3 7/8 - 4 1/2	1 X 1/2

1 3/8" bore bushings also available with 3/8" x 3/16" keyseat.

**Q-D Bushings**

- Can be reverse mounted.
- Setscrew over keyway except JA.
- Stock metric bores - 25 mm - 100 mm.

### Q-D® SHEAVES FOR "A" AND "B" BELTS

Table No.1 Specifications - Stock "B" Sheaves

Part No.	Bushing	Bore Range (in.)	D.D. (in.)		O.L. (in.)	Wt. Less Bushing
			"B" Belts	"A" Belts		
<b>4 Grooves, Face Width = 3 1/4"</b>						
4B34SD	SD	1/2-2	3.4	3.0	3.75	5.5
4B36SD	SD	1/2-2	3.6	3.2	3.95	5.8
4B38SD	SD	1/2-2	3.8	3.4	4.15	6.2
4B40SD	SD	1/2-2	4.0	3.6	4.35	6.6
4B42SD	SD	1/2-2	4.2	3.8	4.55	6.9
4B44SD	SD	1/2-2	4.4	4.0	4.75	7.2
4B46SD	SD	1/2-2	4.6	4.2	4.95	7.6
4B48SD	SD	1/2-2	4.8	4.4	5.15	8.0
4B50SD	SD	1/2-2	5.0	4.6	5.35	8.4
4B52SD	SD	1/2-2	5.2	4.8	5.55	8.8
4B54SD	SD	1/2-2	5.4	5.0	5.75	9.2
4B56SD	SD	1/2-2	5.6	5.2	5.95	9.6
4B58SD	SD	1/2-2	5.8	5.4	6.15	10.0
4B60SD	SD	1/2-2	6.0	5.6	6.35	10.4
4B62SD	SD	1/2-2	6.2	5.8	6.55	10.8
4B64SD	SD	1/2-2	6.4	6.0	6.75	12.0
4B66SD	SD	1/2-2	6.6	6.2	6.95	12.4
4B68SD	SD	1/2-2	6.8	6.4	7.15	13.0
4B70SK	SK	1/2 - 2 5/8	7.0	6.6	7.35	13.5
4B74SK	SK	1/2 - 2 5/8	7.4	7.0	7.75	14.0
4B80SK	SK	1/2 - 2 5/8	8.0	7.6	8.35	15.5
4B86SK	SK	1/2 - 2 5/8	8.6	8.2	8.95	17.0
4B94SK	SK	1/2 - 2 5/8	9.4	9.0	9.75	19.0
4B110SK	SK	1/2 - 2 5/8	11.0	10.6	11.35	22.0
4B124SK	SK	1/2 - 2 5/8	12.4	12.0	12.75	29.0
4B136SK	SK	1/2 - 2 5/8	13.6	13.2	13.95	34.0
4B154SF	SF	1/2 - 2 15/16	15.4	15.0	15.75	39.0
4B160SF	SF	1/2 - 2 15/16	16.0	15.6	16.35	42.0
4B184SF	SF	1/2 - 2 15/16	18.4	18.0	18.75	47.0
4B200SF	SF	1/2 - 2 15/16	20.0	19.6	20.35	51.0
4B250E	E	7/8 - 3 1/2	25.0	24.6	25.35	73.0
4B300E	E	7/8 - 3 1/2	30.0	29.6	30.35	86.0
4B380E	E	7/8 - 3 1/2	38.0	37.6	38.35	109
<b>5 Grooves, Face Width = 4"</b>						
5B34SD	SD	1/2-2	3.4	3.0	3.75	6.1
5B36SD	SD	1/2-2	3.6	3.2	3.95	6.6
5B38SD	SD	1/2-2	3.8	3.4	4.15	7.1
5B40SD	SD	1/2-2	4.0	3.6	4.35	7.4
5B42SD	SD	1/2-2	4.2	3.8	4.55	8.0
5B44SD	SD	1/2-2	4.4	4.0	4.75	8.5
5B46SD	SD	1/2-2	4.6	4.2	4.95	9.0
5B48SD	SD	1/2-2	4.8	4.4	5.15	9.4
5B50SD	SD	1/2-2	5.0	4.6	5.35	10.0
5B52SD	SD	1/2-2	5.2	4.8	5.55	10.4
5B54SK	SK	1/2-2 5/8	5.4	5.0	5.75	10.8
5B56SK	SK	1/2-2 5/8	5.6	5.2	5.95	11.3
5B58SK	SK	1/2-2 5/8	5.8	5.4	6.15	12.0
5B60SK	SK	1/2-2 5/8	6.0	5.6	6.35	14.0
5B62SK	SK	1/2-2 5/8	6.2	5.8	6.55	15.0
5B64SK	SK	1/2-2 5/8	6.4	6.0	6.75	16.0
5B66SK	SK	1/2-2 5/8	6.6	6.2	6.95	17.0
5B68SK	SK	1/2-2 5/8	6.8	6.4	7.15	18.0
5B70SF	SF	1/2 - 2 15/16	7.0	6.6	7.35	19.0
5B74SF	SF	1/2 - 2 15/16	7.4	7.0	7.75	20.0
5B80SF	SF	1/2 - 2 15/16	8.0	7.6	8.35	21.0
5B86SF	SF	1/2 - 2 15/16	8.6	8.2	8.95	22.0
5B94SF	SF	1/2 - 2 15/16	9.4	9.0	9.75	24.0
5B110SF	SF	1/2 - 2 15/16	11.0	10.6	11.35	29.0
5B124SF	SF	1/2 - 2 15/16	12.4	12.0	12.75	34.0
5B136SF	SF	1/2 - 2 15/16	13.6	13.2	13.95	38.0
5B154SF	SF	1/2 - 2 15/16	15.4	15.0	15.75	46.0
5B160SF	SF	1/2 - 2 15/16	16.0	15.6	16.35	49.0
5B184SF	SF	1/2 - 2 15/16	18.4	18.0	18.75	55.0
5B200E	E	7/8 - 3 1/2	20.0	19.6	20.35	65.0
5B250E	E	7/8 - 3 1/2	25.0	24.6	25.35	86.0
5B300E	E	7/8 - 3 1/2	30.0	29.6	30.35	102
5B380E	E	7/8 - 3 1/2	38.0	37.6	38.35	132



- 1 - 8 grooves
- 3.75" - 38.35" O.D.
- 1/2" - 4 1/2" bore range
- Machined from fine grain cast iron
- Precision balanced
- Easy on - easy off

#### Q-D Bushings

- Can be reverse mounted.
- Setscrew over keyway except JA.
- Stock metric bores - 25 mm - 100 mm.

## Q-D® SHEAVES FOR "A" AND "B" BELTS

**Table No.1 Specifications - Stock "B" Sheaves**

Part No.	Bushing	Bore Range (in.)	D.D. (in.)		O.L. (in.)	Wt. Less Bushing
			"B" Belts	"A" Belts		
<b>6 Grooves, Face Width = 4 3/4"</b>						
6B34SD	SD	1/2 - 2	3.4	3.0	3.75	6.7
6B36SD	SD	1/2 - 2	3.6	3.2	3.95	7.4
6B38SD	SD	1/2 - 2	3.8	3.4	4.15	8.0
6B40SD	SD	1/2 - 2	4.0	3.6	4.35	8.4
6B42SD	SD	1/2 - 2	4.2	3.8	4.55	9.0
6B44SD	SD	1/2 - 2	4.4	4.0	4.75	9.7
6B46SD	SD	1/2 - 2	4.6	4.2	4.95	10.1
6B48SD	SD	1/2 - 2	4.8	4.4	5.15	10.6
6B50SD	SD	1/2 - 2	5.0	4.6	5.35	11.0
6B52SD	SD	1/2 - 2	5.2	4.8	5.55	12.0
6B54SK	SK	1/2 - 2 5/8	5.4	5.0	5.75	13.0
6B56SK	SK	1/2 - 2 5/8	5.6	5.2	5.95	14.0
6B58SK	SK	1/2 - 2 5/8	5.8	5.4	6.15	14.6
6B60SK	SK	1/2 - 2 5/8	6.0	5.6	6.35	15.0
6B62SK	SK	1/2 - 2 5/8	6.2	5.8	6.55	16.0
6B64SK	SK	1/2 - 2 5/8	6.4	6.0	6.75	17.0
6B66SK	SK	1/2 - 2 5/8	6.6	6.2	6.95	18.0
6B68SK	SK	1/2 - 2 5/8	6.8	6.4	7.15	19.0
6B70SF	SF	1/2 - 2 15/16	7.0	6.6	7.35	20.0
6B74SF	SF	1/2 - 2 15/16	7.4	7.0	7.75	22.0
6B80SF	SF	1/2 - 2 15/16	8.0	7.6	8.35	24.0
6B86SF	SF	1/2 - 2 15/16	8.6	8.2	8.95	26.0
6B94SF	SF	1/2 - 2 15/16	9.4	9.0	9.75	27.0
6B110SF	SF	1/2 - 2 15/16	11.0	10.6	11.35	32.0
6B124SF	SF	1/2 - 2 15/16	12.4	12.0	12.75	39.0
6B136SF	SF	1/2 - 2 15/16	13.6	13.2	13.95	44.0
6B154SF	SF	1/2 - 2 15/16	15.4	15.0	15.75	50.0
6B160SF	SF	1/2 - 2 15/16	16.0	15.6	16.35	54.0
6B184SF	SF	1/2 - 2 15/16	18.4	18.0	18.75	62.0
6B200E	E	7/8 - 3 1/2	20.0	19.6	20.35	74.0
6B250E	E	7/8 - 3 1/2	25.0	24.6	25.35	96.0
6B300E	E	7/8 - 3 1/2	30.0	29.6	30.35	119
6B380E	E	7/8 - 3 1/2	38.0	37.6	38.35	134
<b>8 Grooves, Face Width = 6 1/4"</b>						
8B54SK	SK	1/2 - 2 5/8	5.4	5.0	5.75	15
8B56SK	SK	1/2 - 2 5/8	5.6	5.2	5.95	16
8B60SF	SF	1/2 - 2 15/16	6.0	5.6	6.35	20
8B64SF	SF	1/2 - 2 15/16	6.4	6.0	6.75	23
8B68SF	SF	1/2 - 2 15/16	6.8	6.4	7.15	25
8B74SF	SF	1/2 - 2 15/16	7.4	7.0	7.75	28
8B86E	E	7/8 - 3 1/2	8.6	8.2	8.95	40
8B94E	E	7/8 - 3 1/2	9.4	9.0	9.75	43
8B110E	E	7/8 - 3 1/2	11.0	10.6	11.35	49
8B124F	F	7/8 - 3 1/2	12.4	12.0	12.75	56
8B154E	E	7/8 - 3 1/2	15.4	15.0	15.75	69
8B184F	F	1 - 4	18.4	18.0	18.75	91
8B200F	F	1 - 4	20.0	19.6	20.35	98
8B250F	F	1 - 4	25.0	24.6	25.35	121
8B300F	F	1 - 4	30.0	29.6	30.35	148
8B380F	F	1 1/4 - 4	38.0	37.6	38.35	194



- 1 - 8 grooves
- 3.75" - 38.35" O.D.
- 1/2" - 4 1/2" bore range
- Machined from fine grain cast iron
- Precision balanced
- Easy on - easy off

**Q-D Bushings**

- Can be reverse mounted.
- Setscrew over keyway except JA.
- Stock metric bores - 25 mm - 100 mm.

## Q-D® SHEAVES FOR "C" BELTS

**Table No.1 Specifications - Stock "C" Sheaves**

Part No.	Bushing	Bore Range (in.)	DATUM "C" (in.)	O.D. (in.)	Wt. Less Bushing
<b>1 Groove, Face Width = 1/4"</b>					
1C70SF	SF	1/2 - 2 15/16	7.0	7.40	10
1C75SF	SF	1/2 - 2 15/16	7.5	7.90	12
1C80SF	SF	1/2 - 2 15/16	8.0	8.40	13
1C85SF	SF	1/2 - 2 15/16	8.5	8.90	14
1C90SF	SF	1/2 - 2 15/16	9.0	9.40	15
1C95SF	SF	1/2 - 2 15/16	9.5	9.90	16
1C100SF	SF	1/2 - 2 15/16	10.0	10.40	17
1C105SF	SF	1/2 - 2 15/16	10.5	10.90	18
1C110SF	SF	1/2 - 2 15/16	11.0	11.40	19
1C120SF	SF	1/2 - 2 15/16	12.0	12.40	20
1C130SF	SF	1/2 - 2 15/16	13.0	13.40	22
1C140SF	SF	1/2 - 2 15/16	14.0	14.40	24
1C160SF	SF	1/2 - 2 15/16	16.0	16.40	26
1C180SF	SF	1/2 - 2 15/16	18.0	18.40	30
1C200SF	SF	1/2 - 2 15/16	20.0	20.40	35
1C240SF	SF	1/2 - 2 15/16	24.0	24.40	41
<b>2 Grooves, Face Width = 2 1/4"</b>					
2C70SF	SF	1/2 - 2 15/16	7.0	7.40	15
2C75SF	SF	1/2 - 2 15/16	7.5	7.90	17
2C80SF	SF	1/2 - 2 15/16	8.0	8.40	18
2C85SF	SF	1/2 - 2 15/16	8.5	8.90	19
2C90SF	SF	1/2 - 2 15/16	9.0	9.40	20
2C95SF	SF	1/2 - 2 15/16	9.5	9.90	21
2C100SF	SF	1/2 - 2 15/16	10.0	10.40	22
2C105SF	SF	1/2 - 2 15/16	10.5	10.90	23
2C110SF	SF	1/2 - 2 15/16	11.0	11.40	24
2C120SF	SF	1/2 - 2 15/16	12.0	12.40	25
2C130SF	SF	1/2 - 2 15/16	13.0	13.40	28
2C140SF	SF	1/2 - 2 15/16	14.0	14.40	31
2C160SF	SF	1/2 - 2 15/16	16.0	16.40	36
2C180SF	SF	1/2 - 2 15/16	18.0	18.40	39
2C200SF	SF	1/2 - 2 15/16	20.0	20.40	48
2C240SF	SF	1/2 - 2 15/16	24.0	24.40	60
2C300F	F	1 - 4	30.0	30.40	85



"C" Belts  
7/8" x 17/32"



- 1 - 8 grooves
- 7.40" - 50.40" O.D.
- 1/2" - 5 1/2" bore range
- Machined from fine grain cast iron
- Precision balanced
- Easy on - easy off

**Q-D Bushings**

- Can be reverse mounted.
- Setscrew over keyway except JA.
- Stock metric bores - 25 mm - 100 mm.

**Table No.2 Standard Keyseats**

Bore Range (in.)	Keyseat (in.)
1/2 - 9/16	1/8 X 1/16
5/8 - 7/8	3/16 X 3/32
15/16 - 1 1/4	1/4 X 1/8
1 5/16 - 1 3/8	5/16 X 5/32
1 7/16 - 1 3/4	3/8 X 3/16
1 13/16 - 2 1/4	1/2 X 1/4
2 5/16 - 2 3/4	5/8 X 5/16
2 13/16 - 3 1/4	3/4 X 3/8
3 3/8 - 3 3/4	7/8 X 7/16
3 7/8 - 4 1/4	1 X 1/2

1 3/8" bore bushings also available with 3/8" x 3/16" keyseat.

## Q-D® SHEAVES FOR "C" BELTS

**Table No.1 Specifications - Stock "C" Sheaves**

Part No.	Bushing	Bore Range (in.)	DATUM "C" (in.)	O.D. (in.)	Wt. Less Bushing
<b>3 Grooves, Face Width = 3 1/4"</b>					
3C50SD	SD	1/2 - 2	5.0	5.40	10
3C55SD	SD	1/2 - 2	5.5	5.90	12
3C60SF	SF	1/2 - 2 15/16	6.0	6.40	15
3C70SF	SF	1/2 - 2 15/16	7.0	7.40	18
3C75SF	SF	1/2 - 2 15/16	7.5	7.90	20
3C80E	E	7/8 - 3 1/2	8.0	8.40	26
3C85E	E	7/8 - 3 1/2	8.5	8.90	29
3C90E	E	7/8 - 3 1/2	9.0	9.40	32
3C95E	E	7/8 - 3 1/2	9.5	9.90	34
3C100E	E	7/8 - 3 1/2	10.0	10.40	36
3C105E	E	7/8 - 3 1/2	10.5	10.90	38
3C110E	E	7/8 - 3 1/2	11.0	11.40	40
3C120E	E	7/8 - 3 1/2	12.0	12.40	43
3C130E	E	7/8 - 3 1/2	13.0	13.40	45
3C140E	E	7/8 - 3 1/2	14.0	14.40	51
3C160E	E	7/8 - 3 1/2	16.0	16.40	59
3C180E	E	7/8 - 3 1/2	18.0	18.40	65
3C200E	E	7/8 - 3 1/2	20.0	20.40	70
3C240E	E	7/8 - 3 1/2	24.0	24.40	80
3C270F	F	1 - 4	27.0	27.40	105
3C300F	F	1 - 4	30.0	30.40	120
3C360F	F	1 - 4	36.0	36.40	140
3C440F	F	1 - 4	44.0	44.40	170
3C500F	F	1 - 4	50.0	50.40	190
<b>4 Grooves, Face Width = 4 1/4"</b>					
4C50SD	SD	1/2 - 2	5.0	5.40	12
4C55SD	SD	1/2 - 2	5.5	5.90	14
4C60SF	SF	1/2 - 2 15/16	6.0	6.40	17
4C70SF	SF	1/2 - 2 15/16	7.0	7.40	21
4C75SF	SF	1/2 - 2 15/16	7.5	7.90	25
4C80E	E	7/8 - 3 1/2	8.0	8.40	30
4C85E	E	7/8 - 3 1/2	8.5	8.90	33
4C90E	E	7/8 - 3 1/2	9.0	9.40	35
4C95E	E	7/8 - 3 1/2	9.5	9.90	48
4C100E	E	7/8 - 3 1/2	10.0	10.40	40
4C105E	E	7/8 - 3 1/2	10.5	10.90	43
4C110E	E	7/8 - 3 1/2	11.0	11.40	46
4C120E	E	7/8 - 3 1/2	12.0	12.40	50
4C130E	E	7/8 - 3 1/2	13.0	13.40	54
4C140E	E	7/8 - 3 1/2	14.0	14.40	59
4C160E	E	7/8 - 3 1/2	16.0	16.40	65
4C180E	E	7/8 - 3 1/2	18.0	18.40	73
4C200E	E	7/8 - 3 1/2	20.0	20.40	82
4C240F	F	1 - 4	24.0	24.40	105
4C270F	F	1 - 4	27.0	27.40	125
4C300F	F	1 - 4	30.0	30.40	142
4C360F	F	1 - 4	36.0	36.40	172
4C440J	J	1 1/2 - 4 1/2	44.0	44.40	225
4C500J	J	1 1/2 - 4 1/2	50.0	50.40	260
<b>5 Grooves, Face Width = 5 1/4"</b>					
5C60SF	SF	1/2 - 2 15/16	6.0	6.40	21
5C70SF	SF	1/2 - 2 15/16	7.0	7.40	26
5C75SF	SF	1/2 - 2 15/16	7.5	7.90	28
5C80E	E	7/8 - 3 1/2	8.0	8.40	33
5C85E	E	7/8 - 3 1/2	8.5	8.90	37
5C90E	E	7/8 - 3 1/2	9.0	9.40	40
5C95E	E	7/8 - 3 1/2	9.5	9.90	42
5C100E	E	7/8 - 3 1/2	10.0	10.40	45
5C105E	E	7/8 - 3 1/2	10.5	10.90	47
5C110E	E	7/8 - 3 1/2	11.0	11.40	50
5C120E	E	7/8 - 3 1/2	12.00	12.40	53
5C130E	E	7/8 - 3 1/2	13.0	13.40	58
5C140E	E	7/8 - 3 1/2	14.0	14.40	64
5C160E	E	7/8 - 3 1/2	16.0	16.40	73
5C180E	E	7/8 - 3 1/2	18.0	18.40	85
5C200F	E	1 - 4	20.0	20.40	98
5C240F	F	1 - 4	24.0	24.40	119
5C270F	F	1 - 4	27.0	27.40	153
5C300F	F	1 - 4	30.0	30.40	174
5C360J	J	1 1/2 - 4 1/2	36.0	36.40	206
5C440J	J	1 1/2 - 4 1/2	44.0	44.40	254
5C500J	J	1 1/2 - 4 1/2	50.0	50.40	274



"C" Belts  
7/8" x 17/32"



- 1 - 8 grooves
- 7.40" - 50.40" O.D.
- 1/2" - 5 1/2" bore range
- Machined from fine grain cast iron
- Precision balanced
- Easy on - easy off

### Q-D Bushings

- Can be reverse mounted.
- Setscrew over keyway except JA.
- Stock metric bores - 25 mm - 100 mm.

**Table No.2 Standard Keyseats**

Bore Range (in.)	Keyseat (in.)
1/2 - 9/16	1/8 X 1/16
5/8 - 7/8	3/16 X 3/32
15/16 - 1 1/4	1/4 X 1/8
1 5/16 - 1 3/8	5/16 X 5/32
1 7/16 - 1 3/4	3/8 X 3/16
1 13/16 - 2 1/4	1/2 X 1/4
2 5/16 - 2 3/4	5/8 X 5/16
2 13/16 - 3 1/4	3/4 X 3/8
3 3/8 - 3 3/4	7/8 X 7/16
3 7/8 - 4 1/2	1 X 1/2
4 5/8 - 5 1/2	1 1/4 X 5/8

1 3/8" bore bushings also available with 3/8" x 3/16" keyseat.

### Q-D® SHEAVES FOR "C" BELTS

Table No.1 Specifications - Stock "C" Sheaves

Part No.	Bushing	Bore Range (in.)	DATUM "C" (in.)	O.D (in.)	Wt. Less Bushing
<b>6 Grooves, Face Width = 6 1/4"</b>					
6C60SF	SF	1/2 - 2 15/16	6.0	6.40	20
6C70SF	SF	1/2 - 2 15/16	7.0	7.40	26
6C75SF	SF	1/2 - 2 15/16	7.5	7.90	29
6C80E	E	7/8 - 3 1/2	8.0	8.40	36
6C85E	E	1 - 4	8.5	8.90	39
6C90F	F	1 - 4	9.0	9.40	51
6C95F	F	1 - 4	9.5	9.90	55
6C100F	F	1 - 4	10.0	10.40	59
6C105F	F	1 - 4	10.5	10.90	62
6C110F	F	1 - 4	11.0	11.40	66
6C120F	F	1 - 4	12.0	12.40	70
6C130F	F	1 - 4	13.0	13.40	74
6C140F	F	1 - 4	14.0	14.40	80
6C160F	F	1 - 4	16.0	16.40	89
6C180F	F	1 - 4	18.0	18.40	102
6C200F	F	1 - 4	20.0	20.40	112
6C240F	F	1 - 4	24.0	24.40	131
6C270J	J	1 1/2 - 4 1/2	27.0	27.40	160
6C300J	J	1 1/2 - 4 1/2	30.0	30.40	190
6C360J	J	1 1/2 - 4 1/2	36.0	36.40	232
6C440J	J	1 1/2 - 4 1/2	44.0	44.40	299
6C500M	M	2 - 5 1/2	50.0	50.40	320
<b>8 Grooves, Face Width = 8 1/4"</b>					
8C80E	E	7/8 - 3 1/2	8.0	8.40	43
8C85E	E	7/8 - 3 1/2	8.5	8.90	48
8C90F	F	1 - 4	9.0	9.40	60
8C95F	F	1 - 4	9.5	9.90	65
8C100F	F	1 - 4	10.0	10.40	69
8C105F	F	1 - 4	10.5	10.90	73
8C110F	F	1 - 4	11.0	11.40	78
8C120F	F	1 - 4	12.0	12.40	83
8C130F	F	1 - 4	13.0	13.40	89
8C140F	F	1 - 4	14.0	14.40	97
8C160F	F	1 - 4	16.0	16.40	113
8C180F	F	1 - 4	18.0	18.40	131
8C200J	J	1/2 - 4 1/2	20.0	20.40	152
8C240J	J	1/2 - 4 1/2	24.0	24.40	185
8C270J	J	1/2 - 4 1/2	27.0	27.40	208
8C300J	J	1/2 - 4 1/2	30.0	30.40	230
8C360M	M	2 - 5 1/2	36.0	36.40	306
8C440M	M	2 - 5 1/2	44.0	44.40	400
8C500M	M	2 - 5 1/2	50.0	50.40	475



"C" Belts  
7/8" x 17/32"



- 1 - 8 grooves
- 7.40" - 50.40" O.D.
- 1/2" - 5 1/2" bore range
- Machined from fine grain cast iron
- Precision balanced
- Easy on - easy off

#### Q-D Bushings

- Can be reverse mounted.
- Setscrew over keyway except JA.
- Stock metric bores - 25 mm - 100 mm.

For additional product information, visit [www.regalrexnord.com/Browning](http://www.regalrexnord.com/Browning)

## Q-D® SHEAVES FOR "3V" BELTS

**Table No.1 Specifications - Stock "D" Sheaves**

Part No.	Bushing	Bore Range (in.)	P.D. "3V" Belts (in.)	O.D. (in.)	Wt. Less Bushing
<b>1 Groove, Face Width = 1/16"</b>					
13V220JA	JA	1/2 - 1 1/4	2.15	2.20	.4
13V235JA	JA	1/2 - 1 1/4	2.30	2.35	.4
13V250JA	JA	1/2 - 1 1/4	2.45	2.50	.5
13V265JA	JA	1/2 - 1 1/4	2.60	2.65	.6
13V280JA	JA	1/2 - 1 1/4	2.75	2.80	.7
13V300JA	JA	1/2 - 1 1/4	2.95	3.00	.8
13V315JA	JA	1/2 - 1 1/4	3.10	3.15	.9
13V335JA	JA	1/2 - 1 1/4	3.30	3.35	1.0
13V365SH	SH	1/2 - 1 5/8	3.60	3.65	1.3
13V412SH	SH	1/2 - 1 5/8	4.07	4.12	1.8
13V450SH	SH	1/2 - 1 5/8	4.45	4.50	2.1
13V475SH	SH	1/2 - 1 5/8	4.70	4.75	2.4
13V500SH	SH	1/2 - 1 5/8	4.95	5.00	2.7
13V530SH	SH	1/2 - 1 5/8	5.25	5.30	2.9
13V560SH	SH	1/2 - 1 5/8	5.55	5.60	3.0
13V600SH	SH	1/2 - 1 5/8	5.95	6.00	3.2
13V650SH	SH	1/2 - 1 5/8	6.45	6.50	4.2
13V690SH	SH	1/2 - 1 5/8	6.85	6.90	4.4
13V800SDS	SDS	1/2-2	7.95	8.00	5.8
13V1060SDS	SDS	1/2-2	10.55	10.60	7.9
13V1400SK	SK	1/2 - 2 5/8	13.95	14.00	14.8
13V1900SK	SK	1/2 - 2 5/8	18.95	19.00	24.0
<b>2 Grooves, Face Width = 1 3/32"</b>					
23V220JA	JA	1/2 - 1 1/4	2.15	2.20	.6
23V235JA	JA	1/2 - 1 1/4	2.30	2.35	.6
23V250JA	JA	1/2 - 1 1/4	2.45	2.50	.7
23V265JA	JA	1/2 - 1 1/4	2.60	2.65	.8
23V280JA	JA	1/2 - 1 1/4	2.75	2.80	.9
23V300JA	JA	1/2 - 1 1/4	2.95	3.00	1.2
23V315JA	JA	1/2 - 1 1/4	3.10	3.15	1.2
23V335SH	SH	1/2 - 1 5/8	3.30	3.35	1.3
23V365SH	SH	1/2 - 1 5/8	3.60	3.65	1.5
23V412SH	SH	1/2 - 1 5/8	4.07	4.12	2.2
23V450SH	SH	1/2 - 1 5/8	4.45	4.50	2.7
23V475SH	SH	1/2 - 1 5/8	4.70	4.75	3.1
23V500SH	SH	1/2 - 1 5/8	4.95	5.00	3.4
23V530SH	SH	1/2 - 1 5/8	5.25	5.30	3.9
23V560SH	SH	1/2 - 1 5/8	5.55	5.60	4.0
23V600SH	SH	1/2 - 1 5/8	5.95	6.00	4.4
23V650SDS	SDS	1/2 - 2	6.45	6.50	6.0
23V690SDS	SDS	1/2 - 2	6.85	6.90	7.5
23V800SDS	SDS	1/2 - 2	7.95	8.00	8.5
23V1060SK	SK	1/2 - 2 5/8	10.55	10.60	12.5
23V1400SK	SK	1/2 - 2 5/8	13.95	14.00	19.5
23V1900SK	SK	1/2 - 2 5/8	18.95	19.00	27.0
23V2500SF	SF	1/2 - 2 15/16	24.95	25.00	38.0



- 1 - 8 grooves
- 2.20" - 33.50" O.D.
- 1/2" - 5 1/2" bore range
- Machined from fine grain cast iron
- Precision balanced
- Easy on - easy off

### Q-D Bushings

- Can be reverse mounted.
- Setscrew over keyway except JA.
- Stock metric bores - 25 mm - 100 mm.

For additional product information, visit [www.regalrexnord.com/Browning](http://www.regalrexnord.com/Browning)

### Q-D® SHEAVES FOR "3V" BELTS

**Table No.1 Specifications - Stock "3V" Sheaves**

Part No.	Bushing	Bore Range (in.)	P.D. "3V" Belts (in.)	O.D. (in.)	Wt. Less Bushing
<b>3 Grooves, Face Width = 1 1/2"</b>					
33V250JA	JA	1/2 - 1 1/4	2.45	2.50	.8
33V265JA	JA	1/2 - 1 1/4	2.60	2.65	1.0
33V280JA	JA	1/2 - 1 1/4	2.75	2.80	1.4
33V300SH	SH	1/2 - 1 5/8	2.95	3.00	1.7
33V315SH	SH	1/2 - 1 5/8	3.10	3.15	1.8
33V335SH	SH	1/2 - 1 5/8	3.30	3.35	1.9
33V365SH	SH	1/2 - 1 5/8	3.60	3.65	2.3
33V412SH	SH	1/2 - 1 5/8	4.07	4.12	2.8
33V450SDS	SDS	1/2 - 2	4.45	4.50	3.5
33V475SDS	SDS	1/2 - 2	4.70	4.75	4.0
33V500SDS	SDS	1/2 - 2	4.95	5.00	4.5
33V530SDS	SDS	1/2 - 2	5.25	5.30	5.2
33V560SDS	SDS	1/2 - 2	5.55	5.60	6.0
33V600SDS	SDS	1/2 - 2	5.95	6.00	7.0
33V650SDS	SDS	1/2 - 2	6.45	6.50	8.1
33V690SDS	SDS	1/2 - 2	6.85	6.90	8.9
33V800SK	SK	1/2 - 2 5/8	7.95	8.00	11.3
33V1060SK	SK	1/2 - 2 5/8	10.55	10.60	14.0
33V1400SK	SK	1/2 - 2 5/8	13.95	14.00	21.6
33V1900SF	SF	1/2 - 2 15/16	18.95	19.00	32.1
33V2500SF	SF	1/2 - 2 15/16	24.95	25.00	50.0
33V3350SF	SF	1/2 - 2 15/16	33.45	33.50	78.0
<b>4 Grooves, Face Width = 1 29/32"</b>					
43V265JA	JA	1/2 - 1 1/4	2.60	2.65	1.3
43V280JA	JA	1/2 - 1 1/4	2.75	2.80	1.7
43V300SH	SH	1/2 - 1 5/8	2.95	3.00	2.0
43V315SH	SH	1/2 - 1 5/8	3.10	3.15	2.2
43V335SH	SH	1/2 - 1 5/8	3.30	3.35	2.3
43V365SH	SH	1/2 - 1 5/8	3.60	3.65	2.8
43V412SH	SH	1/2 - 1 5/8	4.07	4.12	3.4
43V450SDS	SDS	1/2 - 2	4.45	4.50	4.0
43V475SDS	SDS	1/2 - 2	4.70	4.75	4.6
43V500SDS	SDS	1/2 - 2	4.95	5.00	5.2
43V530SDS	SDS	1/2 - 2	5.25	5.30	5.8
43V560SDS	SDS	1/2 - 2	5.55	5.60	6.8
43V600SK	SK	1/2 - 2 5/8	5.95	6.00	8.3
43V650SK	SK	1/2 - 2 5/8	6.45	6.50	10.0
43V690SK	SK	1/2 - 2 5/8	6.85	6.90	11.9
43V800SK	SK	1/2 - 2 5/8	7.95	8.00	13.0
43V1060SK	SK	1/2 - 2 5/8	10.55	10.60	16.5
43V1400SK	SK	1/2 - 2 5/8	13.95	14.00	22.5
43V1900SF	SF	1/2 - 2 15/16	18.95	19.00	35.0
43V2500SF	SF	1/2 - 2 15/16	24.95	25.00	57.0
43V3350E	SF	1/2 - 3 1/2	33.45	33.50	84.0



- 1 - 8 grooves
- 2.20" - 33.50" O.D.
- 1/2" - 5 1/2" bore range
- Machined from fine grain cast iron
- Precision balanced
- Easy on - easy off

**Q-D Bushings**

- Can be reverse mounted.
- Setscrew over keyway except JA.
- Stock metric bores - 25mm - 100mm.

**Table No.2 Standard Keyseats**

Bore Range (in.)	Keyseat (in.)	Bore Range (in.)	Keyseat (in.)
1/2 - 9/16	1/8 x 1/16	1 3/16 - 2 1/4	1/2 x 1/4
5/8 - 7/8	3/16 x 3/32	2 5/16 - 2 - 3/4	5/8 x 5/16
15/16 - 1 1/4	1/4 x 1/8	2 13/16 - 3 1/4	3/4 x 3/8
1 5/16 - 1 3/8	5/16 x 5/32	3 3/8 - 3 3/4	7/8 x 7/16
1 7/16 - 1 3/4	3/8 x 3/16	3 7/8 - 4	1 x 1/2

1 3/8" bore bushings also available with 3/8" x 3/16" keyseat.

## Q-D® SHEAVES FOR "3V" BELTS

**Table No.1 Specifications - Stock "3V" Sheaves**

Part No.	Bushing	Bore Range (in.)	P.D. "3V" Belts (in.)	O.D. (in.)	Wt. Less Bushing
<b>5 Grooves, Face Width = 2 5/16"</b>					
53V475SDS	SDS	1/2 - 2	4.70	4.75	5.1
53V500SDS	SDS	1/2 - 2	4.95	5.00	5.7
53V530SK	SK	1/2 - 2 5/8	5.25	5.30	6.5
53V560SK	SK	1/2 - 2 5/8	5.55	5.60	7.5
53V600SK	SK	1/2 - 2 5/8	5.95	6.00	8.9
53V650SK	SK	1/2 - 2 5/8	6.45	6.50	10.6
53V690SK	SK	1/2 - 2 5/8	6.85	6.90	12.8
53V800SK	SK	1/2 - 2 5/8	7.95	8.00	13.6
53V1060SK	SK	1/2 - 2 5/8	10.55	10.60	17.0
53V1400SF	SF	1/2 - 2 15/16	13.95	14.00	26.0
53V1900SF	SF	1/2 - 2 15/16	18.95	19.00	41.0
53V2500E	E	7/8 - 3 1/2	24.95	25.00	63.0
53V3350E	E	7/8 - 3 1/2	33.45	33.50	95.0
<b>6 Grooves, Face Width = 2 23/32"</b>					
63V475SK	SK	1/2 - 2 5/8	4.70	4.75	6.0
63V500SK	SK	1/2 - 2 5/8	4.95	5.00	6.3
63V530SK	SK	1/2 - 2 5/8	5.25	5.30	6.9
63V560SK	SK	1/2 - 2 5/8	5.55	5.60	8.5
63V600SK	SK	1/2 - 2 5/8	5.95	6.00	9.8
63V650SK	SK	1/2 - 2 5/8	6.45	6.50	11.4
63V690SK	SK	1/2 - 2 5/8	6.85	6.90	13.4
63V800SK	SK	1/2 - 2 5/8	7.95	8.00	15.0
63V1060SF	SF	1/2 - 2 15/16	10.55	10.60	22.6
63V1400SF	SF	1/2 - 2 15/16	13.95	14.00	29.5
63V1900E	E	7/8 - 3 1/2	18.95	19.00	44.0
63V2500E	E	7/8 - 3 1/2	24.95	25.00	65.0
63V3350E	E	7/8 - 3 1/2	33.45	33.50	101.0
<b>8 Grooves, Face Width = 3 17/32"</b>					
83V475SK	SK	1/2 - 2 5/8	4.70	4.75	7.2
83V500SK	SK	1/2 - 2 5/8	4.95	5.00	7.8
83V530SK	SK	1/2 - 2 5/8	5.25	5.30	9.3
83V560SK	SK	1/2 - 2 5/8	5.55	5.60	10.5
83V600SK	SK	1/2 - 2 5/8	5.95	6.00	12.5
83V650SK	SK	1/2 - 2 5/8	6.45	6.50	16.0
83V690SK	SK	1/2 - 2 5/8	6.85	6.90	18.0
83V800SF	SF	1/2 - 2 15/16	7.95	8.00	21.0
83V1060SF	SF	1/2 - 2 15/16	10.55	10.60	25.5
83V1400E	E	7/8 - 3 1/2	13.95	14.00	38.5
83V1900E	E	7/8 - 3 1/2	18.95	19.00	54.0
83V2500E	E	7/8 - 3 1/2	24.95	25.00	80.0
83V3350F	F	1 - 4	33.45	33.50	132.0



- 1 - 8 grooves
- 2.20" - 33.50" O.D.
- 1/2" - 5 1/2" bore range
- Machined from fine grain cast iron
- Precision balanced
- Easy on - easy off

**Q-D Bushings**

- Can be reverse mounted.
- Setscrew over keyway except JA.
- Stock metric bores - 25 mm - 100 mm.

### Q-D® SHEAVES FOR "5V" BELTS

**Table No.1 Specifications - Stock "5V" Sheaves**

Part No.	Bushing	Bore Range (in.)	P.D. "5V" Belts (in.)	O.D. (in.)	Wt. Less Bushing
<b>2 Grooves, Face Width = 1 11/16"</b>					
25V440SH	SH	1/2-1 5/8	4.30	4.40	5.8
25V465SDS	SDS	1/2-2	4.55	4.65	6.6
25V490SDS	SDS	1/2-2	4.80	4.90	6.8
25V520SDS	SDS	1/2-2	5.10	5.20	7.0
25V550SDS	SDS	1/2-2	5.40	5.50	7.2
25V590SDS	SDS	1/2-2	5.80	5.90	7.6
25V630SK	SK	1/2-2 5/8	6.20	6.30	9.4
25V670SK	SK	1/2-2 5/8	6.60	6.70	10.5
25V710SK	SK	1/2-2 5/8	7.00	7.10	11.5
25V750SK	SK	1/2-2 5/8	7.40	7.50	12.5
25V800SK	SK	1/2-2 5/8	7.90	8.00	13.0
25V850SK	SK	1/2-2 5/8	8.40	8.50	14.0
25V900SK	SK	1/2-2 5/8	8.90	9.00	15.2
25V925SK	SK	1/2-2 5/8	9.15	9.25	15.3
25V975SK	SK	1/2-2 5/8	9.65	9.75	15.5
25V1030SK	SK	1/2-2 5/8	10.20	10.30	15.5
25V1090SK	SK	1/2-2 5/8	10.80	10.90	16.5
25V1130SK	SK	1/2-2 5/8	11.20	11.30	17.8
25V1180SK	SK	1/2-2 5/8	11.70	11.80	19.0
25V1250SF	SF	1/2-2 15/16	12.40	12.50	21.0
25V1320SF	SF	1/2-2 15/16	13.10	13.20	22.6
25V1400SF	SF	1/2-2 15/16	13.90	14.00	25.3
25V1500SF	SF	1/2-2 15/16	14.90	15.00	27.4
25V1600SF	SF	1/2-2 15/16	15.90	16.00	29.2
25V1870SF	SF	1/2-2 15/16	18.60	18.70	36.0
25V2120SF	SF	1/2-2 15/16	21.10	21.20	43.0
25V2360E	E	7/8-3 1/2	23.50	23.60	55.0
25V2800E	E	7/8-3 1/2	27.90	28.00	67.0



5V  
5/8" x 17/32"



- 2 - 8 grooves
- 4.40" - 50.00" O.D.
- 1/2" - 5 1/2" bore range
- Machined from fine grain cast iron
- Precision balanced
- Easy on - easy off

**3 Grooves, Face Width = 2 3/8" (Part)**

35V440SDS	SDS	1/2-2	4.30	4.40	6.5
35V465SDS	SDS	1/2-2	4.55	4.65	7.6
35V490SDS	SDS	1/2-2	4.80	4.90	7.8
35V520SDS	SDS	1/2-2	5.10	5.20	8.0
35V550SDS	SDS	1/2-2	5.40	5.50	8.2
35V590SDS	SDS	1/2-2	5.80	5.90	8.6
35V630SK	SK	1/2-2 5/8	6.20	6.30	10.4
35V670SK	SK	1/2-2 5/8	6.60	6.70	11.7
35V710SF	SF	1/2-2 15/16	7.00	7.10	12.7
35V750SF	SF	1/2-2 15/16	7.40	7.50	15.0
35V800SF	SF	1/2-2 15/16	7.90	8.00	16.5
35V850SF	SF	1/2-2 15/16	8.40	8.50	18.0
35V900SF	SF	1/2-2 15/16	8.90	9.00	19.8
35V925SF	SF	1/2-2 15/16	9.15	9.25	20.7
35V975SF	SF	1/2-2 15/16	9.65	9.75	22.6
35V1030SF	SF	1/2-2 15/16	10.20	10.30	24.6
35V1090SF	SF	1/2-2 15/16	10.80	10.90	26.7
35V1130SF	SF	1/2-2 15/16	11.20	11.30	28.2
35V1180SF	SF	1/2-2 15/16	11.70	11.80	29.7
35V1250E	E	7/8-3 1/2	12.40	12.50	34.0
35V1320E	E	7/8-3 1/2	13.10	13.20	35.0

**Q-D Bushings**

- Can be reverse mounted.
- Setscrew over keyway except JA.
- Stock metric bores - 25 mm - 100 mm.

**Table No.2 Standard Keyseats**

Bore Range (in.)	Keyseat (in.)
1/2-9/16	1/8 x 1/16
5/8-7/8	3/16 x 3/32
15/16-1 1/4	1/4 x 1/8
1 5/16-1 3/8	5/16 x 5/32
1 7/16-1 3/4	3/8 x 3/16
1 13/16-2 1/4	1/2 x 1/4
2 5/16-2 3/4	5/8 x 5/16
2 13/16-3 1/4	3/4 x 3/8
3 3/8-3 3/4	7/8 x 7/16
3 7/8-4 1/4	1 x 1/2
4 9/16-5 1/2	1 1/4 x 5/8

1 3/8" bore bushings also available with 3/8" x 3/16" keyseat.

## Q-D® SHEAVES FOR "5V" BELTS

**Table No.1 Specifications - Stock "5V" Sheaves**

Part No.	Bushing	Bore Range (in.)	P.D. "5V" Belts (in.)	O.D. (in.)	Wt. Less Bushing
<b>3 Grooves, Face Width = 2 3/8" (Part)</b>					
35V1400E	E	7/8-3 1/2	13.90	14.00	37
35V1500E	E	7/8-3 1/2	14.9	15	38
35V1600E	E	7/8-3 1/2	15.9	16	39.2
35V1870E	E	7/8-3 1/2	18.6	18.7	47.2
35V2120E	E	7/8-3 1/2	21.1	21.2	55
35V2360E	E	7/8-3 1/2	23.5	23.6	70.2
35V2800E	E	7/8-3 1/2	27.9	28	86.5
35V3150F	F	1-4	31.4	31.5	116
35V3750F	F	1-4	37.4	37.5	141
35V5000F	F	1-4	49.9	50	211
<b>4 Grooves, Face Width = 3 1/16"</b>					
45V440SD	SD	1/2-2	4.3	4.4	7.5
45V465SD	SD	1/2-2	4.55	4.65	8
45V490SD	SD	1/2-2	4.8	4.9	8.5
45V520SD	SD	1/2-2	5.1	5.2	8.8
45V550SD	SD	1/2-2	5.4	5.5	9.3
45V590SD	SD	1/2-2	5.8	5.9	10.1
45V630SK	SK	1/2-2 5/8	6.2	6.3	11.8
45V670SK	SK	1/2-2 5/8	6.6	6.7	13.6
45V710SF	SF	1/2-2 15/16	7	7.1	14.9
45V750SF	SF	1/2-2 15/16	7.4	7.5	17
45V800E	E	7/8-3 1/2	7.9	8	18.8
45V850E	E	7/8-3 1/2	8.4	8.5	21.9
45V900E	E	7/8-3 1/2	8.9	9	24.2
45V925E	E	7/8-3 1/2	9.15	9.25	25.8
45V975E	E	7/8-3 1/2	9.65	9.75	28.2
45V1030E	E	7/8-3 1/2	10.2	10.3	29.8
45V1090E	E	7/8-3 1/2	10.8	10.9	30.6
45V1130E	E	7/8-3 1/2	11.2	11.3	31.9
45V1180E	E	7/8-3 1/2	11.7	11.8	33
45V1250E	E	7/8-3 1/2	12.4	12.5	36.4
45V1320E	E	7/8-3 1/2	13.1	13.2	38.2
45V1400E	E	7/8-3 1/2	13.9	14	40.2
45V1500E	E	7/8-3 1/2	14.9	15	43.5
45V1600E	E	7/8-3 1/2	15.9	16	44.6
45V1870E	E	7/8-3 1/2	18.6	18.7	53.6
45V2120E	E	7/8-3 1/2	21.1	21.2	62.5
45V2360F	F	1-4	23.5	23.6	83.5
45V2800F	F	1-4	27.9	28	126
45V3150F	F	1-4	31.4	31.5	148
45V3750F	F	1-4	37.4	37.5	170
45V5000J	J	1 1/2-4 1/2	49.9	50	248



5V  
5/8" x 17/32"



- 2 - 8 grooves
- 4.40" - 50.00" O.D.
- 1/2" - 5 1/2" bore range
- Machined from fine grain cast iron
- Precision balanced
- Easy on - easy off

### Q-D Bushings

- Can be reverse mounted.
- Setscrew over keyway except JA.
- Stock metric bores - 25 mm - 100 mm.

### Q-D® SHEAVES FOR "5V" BELTS

**Table No.1 Specifications - Stock "5V" Sheaves**

Part No.	Bushing	Bore Range (in.)	P.D. "5V" Belts (in.)	O.D. (in.)	Wt. Less Bushing
<b>5 Grooves, Face Width = 3 3/4"</b>					
55V440SD	SD	1/2-2	4.30	4.40	8.9
55V465SD	SD	1/2-2	4.55	4.65	9.2
55V490SD	SD	1/2-2	4.8	4.9	10.1
55V520SD	SD	1/2-2	5.1	5.2	10.8
55V550SD	SD	1/2-2	5.4	5.5	12
55V590SK	SK	1/2-2 5/8	5.8	5.9	13.2
55V630SK	SK	1/2-2 5/8	6.2	6.3	15.9
55V670SF	SF	1/2-2 15/16	6.6	6.6	18.6
55V710SF	SF	1/2-2 15/16	7	7.1	21.7
55V750SF	SF	1/2-2 15/16	7.4	7.5	22.8
55V800E	E	7/8-3 1/2	7.9	8	23.7
55V850E	E	7/8-3 1/2	8.4	8.5	24.8
55V900E	E	7/8-3 1/2	8.9	9	26.3
55V925E	E	7/8-3 1/2	9.15	9.25	28.2
55V975E	E	7/8-3 1/2	9.65	9.75	32
55V1030E	E	7/8-3 1/2	10.2	10.3	33
55V1090E	E	7/8-3 1/2	10.8	10.9	35
55V1130E	E	7/8-3 1/2	11.2	11.3	36.5
55V1180E	E	7/8-3 1/2	11.7	11.8	38
55V1250E	E	7/8-3 1/2	12.4	12.5	40.8
55V1320E	E	7/8-3 1/2	13.1	13.2	42.3
55V1400E	E	7/8-3 1/2	13.9	14	44.6
55V1500E	E	7/8-3 1/2	14.9	15	48.2
55V1600E	E	7/8-3 1/2	15.9	16	51.2
55V1870F	F	1-4	18.6	18.7	70.2
55V2120F	F	1-4	21.1	21.2	89
55V2360F	F	1-4	23.5	23.6	105
55V2800F	F	1-4	27.9	28	123
55V3150J	J	1 1/2-4 1/2	31.4	31.5	151
55V3750J	J	1 1/2-4 1/2	37.4	37.5	190
55V5000J	J	1 1/2-4 1/2	49.9	50	278



5V  
5/8" x 17/32"



- 2 - 8 grooves
- 4.40" - 50.00" O.D.
- 1/2" - 5 1/2" bore range
- Machined from fine grain cast iron
- Precision balanced
- Easy on - easy off

**Q-D Bushings**

- Can be reverse mounted.
- Setscrew over keyway except JA.
- Stock metric bores - 25 mm - 100 mm.

**6 Grooves, Face Width = 4 7/16"**

65V440SD	SD	1/2-2	4.3	4.4	10.1
65V465SD	SD	1/2-2	4.55	4.65	10.4
65V490SD	SD	1/2-2	4.8	4.9	11.2
65V520SD	SD	1/2-2	5.1	5.2	12.1
65V550SD	SD	1/2-2	5.4	5.5	13.3
65V590SK	SK	1/2-2 5/8	5.8	5.9	14.6
65V630SK	SK	1/2-2 5/8	6.2	6.3	17.4
65V670SF	SF	1/2-2 15/16	6.6	6.7	20
65V710SF	SF	1/2-2 15/16	7	7.1	21.9
65V750SF	SF	1/2-2 15/16	7.4	7.5	23.4
65V800E	E	7/8-3 1/2	7.9	8	24.2
65V850E	E	7/8-3 1/2	8.4	8.5	26.7
65V900E	E	7/8-3 1/2	8.9	9	28.5
65V925E	E	7/8-3 1/2	9.15	9.25	30.2
65V975E	E	7/8-3 1/2	9.65	9.75	33.8
65V1030E	E	7/8-3 1/2	10.2	10.3	36.6
65V1090E	E	7/8-3 1/2	10.8	10.9	38.1
65V1130E	E	7/8-3 1/2	11.2	11.3	39.8
65V1180E	E	7/8-3 1/2	11.7	11.8	41.2
65V1250F	F	1-4	12.4	12.5	58.2
65V1320F	F	1-4	13.1	13.2	64
65V1400F	F	1-4	13.9	14	66
65V1500F	F	1-4	14.9	15	68
65V1600F	F	1-4	15.9	16	77.5
65V1870F	F	1-4	18.6	18.7	85.8
65V2120F	F	1-4	21.1	21.2	96
65V2360J	J	1 1/2-4 1/2	23.5	23.6	113
65V2800J	J	1 1/2-4 1/2	27.9	28	148
65V3150J	J	1 1/2-4 1/2	31.4	31.5	183
65V3750J	J	1 1/2-4 1/2	37.4	37.5	218
65V5000M	M	2-5 1/2	49.90	50.00	310

**Table No.2 Standard Keyseats**

Bore Range (in.)	Keyseat (in.)
1/2-9/16	1/8 x 1/16
5/8-7/8	3/16 x 3/32
15/16-1 1/4	1/4 x 1/8
1 5/16-1 3/8	5/16 x 5/32
1 7/16-1 3/4	3/8 x 3/16
1 13/16-2 1/4	1/2 x 1/4
2 5/16-2 3/4	5/8 x 5/16
2 13/16-3 1/4	3/4 x 3/8
3 3/8-3 3/4	7/8 x 7/16
3 7/8-4 1/4	1 x 1/2
4 9/16-5 1/2	1 1/4 x 5/8

1 3/8" bore bushings also available with 3/8" x 3/16" keyseat.

## Q-D® SHEAVES FOR "5V" BELTS

**Table No.1 Specifications - Stock "5V" Sheaves**

Part No.	Bushing	Bore Range (in.)	P.D. "5V" Belts (in.)	O.D. (in.)	Wt. Less Bushing
<b>8 Grooves, Face Width = 5 13/16"</b>					
85V710SF	SF	1/2-2 15/16	7.00	7.10	24.7
85V750SF	SF	1/2-2 15/16	7.40	7.50	28.2
85V800E	E	7/8-3 1/2	7.90	8.00	35.0
85V850E	E	7/8-3 1/2	8.40	8.50	37.2
85V900E	E	7/8-3 1/2	8.90	9.00	42.0
85V925F	F	1-4	9.15	9.25	44.0
85V975F	F	1-4	9.65	9.75	48.4
85V1030F	F	1-4	10.20	10.30	58.4
85V1090F	F	1-4	10.80	10.90	63.1
85V1130F	F	1-4	11.20	11.30	67.0
85V1180F	F	1-4	11.70	11.80	71.0
85V1250F	F	1-4	12.40	12.50	76.0
85V1320F	F	1-4	13.10	13.20	80.0
85V1400F	F	1-4	13.90	14.00	81.0
85V1500F	F	1-4	14.90	15.00	83.0
85V1600F	F	1-4	15.90	16.00	90.0
85V1870J	J	1 1/2-4 1/2	18.60	18.70	120
85V2120J	J	1 1/2-4 1/2	21.10	21.20	152
85V2360J	J	1 1/2-4 1/2	23.50	23.60	185
85V2800J	J	1 1/2-4 1/2	27.90	28.00	210
85V3150M	M	2-5 1/2	31.40	31.50	242
85V3750M	M	2-5 1/2	37.40	37.50	285
85V5000M	M	2-5 1/2	49.90	50.00	408



5V  
5/8" x 17/32"



- 2 - 8 grooves
- 4.40" - 50.00" O.D.
- 1/2" - 5 1/2" bore range
- Machined from fine grain cast iron
- Precision balanced
- Easy on - easy off

### Q-D Bushings

- Can be reverse mounted.
- Setscrew over keyway except JA.
- Stock metric bores - 25 mm - 100 mm.

For additional product information, visit [www.regalrexnord.com/Browning](http://www.regalrexnord.com/Browning)

### Q-D® SHEAVES FOR "8V" BELTS

**Table No.1 Specifications - Stock "8V" Sheaves**

Part No.	Bushing	Bore Range (in.)	P.D. "8V" Belts (in.)	O.D. (in.)	Wt. Less Bushing
<b>4 Grooves, Face Width = 4 7/8"</b>					
48V1250F	F	1-4	12.30	12.50	75
48V1320F	F	1-4	13.00	13.20	81
48V1400F	F	1-4	13.80	14.00	87
48V1500F	F	1-4	14.80	15.00	91
48V1600F	F	1-4	15.80	16.00	96
48V1700F	F	1-4	16.80	17.00	104
48V1800F	F	1-4	17.80	18.00	114
48V1900F	F	1-4	18.80	19.00	121
48V2000J	J	1 1/2-4 1/2	19.80	20.00	136
48V2120J	J	1 1/2-4 1/2	21.00	21.20	145
48V2240J	J	1 1/2-4 1/2	22.00	22.40	154
48V2480M	M	2-5 1/2	24.60	24.80	176
48V3000M	M	2-5 1/2	29.80	30.00	224
48V3550M	M	2-5 1/2	35.30	35.50	267
48V4000M	M	2-5 1/2	39.80	40.00	310
48V4450M	M	2-5 1/2	44.30	44.50	363
48V5300M	M	2-5 1/2	52.80	53.00	437
<b>5 Grooves, Face Width = 6"</b>					
58V1250F	F	1-4	12.30	12.50	82
58V1320F	F	1-4	13.00	13.20	89
58V1400F	F	1-4	13.80	14.00	99
58V1500F	F	1-4	14.80	15.00	103
58V1600F	F	1-4	15.80	16.00	111
58V1700J	J	1 1/2-4 1/2	16.80	17.00	119
58V1800J	J	1 1/2-4 1/2	17.80	18.00	131
58V1900J	J	1 1/2-4 1/2	18.80	19.00	142
58V2000J	J	1 1/2-4 1/2	19.80	20.00	151
58V2120J	J	1 1/2-4 1/2	21.00	21.20	167
58V2240M	M	2-5 1/2	22.20	22.40	178
58V2480M	M	2-5 1/2	24.60	24.80	201
58V3000M	M	2-5 1/2	29.80	30.00	243
58V3550M	M	2-5 1/2	35.30	35.50	278
58V4000M	M	2-5 1/2	39.80	40.00	340
58V4450N	N	2 7/16-5 7/8	44.30	44.50	418
58V5300N	N	2 7/16-5 7/8	52.80	53.00	496
<b>6 Grooves, Face Width = 7 1/8"</b>					
68V1250F	F	1-4	12.30	12.50	90
68V1320F	F	1-4	13.00	13.20	98
68V1400F	F	1-4	13.80	14.00	112
68V1500J	J	1 1/2-4 1/2	14.80	15.00	123
68V1600J	J	1 1/2-4 1/2	15.80	16.00	129
68V1700J	J	1 1/2-4 1/2	16.80	17.00	136
68V1800J	J	1 1/2-4 1/2	17.80	18.00	143
68V1900J	J	1 1/2-4 1/2	18.80	19.00	157
68V2000M	M	2-5 1/2	19.80	20.00	179
68V2120M	M	2-5 1/2	21.00	21.20	193
68V2240M	M	2-5 1/2	22.20	22.40	205
68V2480M	M	2-5 1/2	24.60	24.80	235
68V3000M	M	2-5 1/2	29.80	30.00	285
68V3550N	N	2 7/16-5 7/8	35.3	35.5	340
68V4000N	N	2 7/16-5 7/8	39.8	40	394
68V4450N	N	2 7/16-5 7/8	44.3	44.5	489
68V5300N	N	2 7/16-5 7/8	52.8	53	584

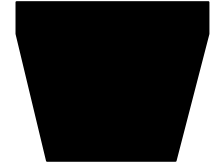

8V  
1" x 29/32"



- 4 - 8 grooves
- 12.50" - 53.00" O.D.
- 1" - 7" bore range
- Machined from fine grain cast iron
- Precision balanced
- Easy on - easy off

**Q-D Bushings**

- Can be reverse mounted.
- Setscrew over keyway except JA.
- Stock metric bores - 25 mm - 100 mm.

**Table No.2 Standard Keyseats**

Bore Range (in.)	Keyseat (in.)
1 - 1 1/4	1/4 x 1/8
1 5/16 - 1 3/8	5/16 x 5/32
1 7/16 - 1 3/4	3/8 x 3/16
1 13/16 - 2 1/4	1/2 x 1/4
2 5/16 - 2 3/4	5/8 x 5/16
2 13/16 - 3 1/4	3/4 x 3/8
3 3/8 - 3 3/4	7/8 x 7/16
3 7/8 - 4 1/4	1 x 1/2
4 9/16 - 5 1/2	1 1/4 x 5/8
5 9/16 - 6 1/2	1 1/2 x 3/4
6 9/16 - 7	1 3/4 x 5/8

1 3/8" bore bushings also available with 3/8" x 3/16" keyseat.

## Q-D® SHEAVES FOR "8V" BELTS

**Table No.1 Specifications - Stock "8V" Sheaves**

Part No.	Bushing	Bore Range (in.)	P.D "8V" Belts (in.)	O.D. (in.)	Wt. Less Bushing
<b>8 Grooves, Face Width = 9 3/8"</b>					
88V1250J	J	1 1/2-4 1/2	12.3	12.5	131
88V1320J	J	1 1/2-4 1/2	13	13.2	160
88V1400J	J	1 1/2-4 1/2	13.8	14	175
88V1500J	J	1 1/2-4 1/2	14.8	15	186
88V1600J	J	1 1/2-4 1/2	15.8	16	210
88V1700M	M	2-5 1/2	16.8	17	221
88V1800M	M	2-5 1/2	17.8	18	235
88V1900M	M	2-5 1/2	18.8	19	250
88V2000M	M	2-5 1/2	19.8	20	265
88V2120M	M	2-5 1/2	21	21.2	280
88V2240M	M	2-5 1/2	22.2	22.4	295
88V2480N	N	2 7/16-5 7/8	24.6	24.8	320
88V3000N	N	2 7/16-5 7/8	29.8	30	375
88V3550N	N	2 7/16-5 7/8	35.3	35.5	442
88V4000N	N	2 7/16-5 7/8	39.8	40	530
88V4450P	P	2 15/16-7	44.3	44.5	610
88V5300P	P	2 15/16-7	52.8	53	795
88V6300P	P	2 15/16-7	62.8	63	995

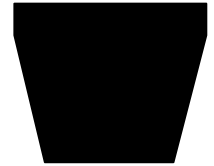

8V  
1" x 29/32"



- 4 - 8 grooves
- 12.50" - 53.00" O.D.
- 1" - 7" bore range
- Machined from fine grain cast iron
- Precision balanced
- Easy on - easy off

### Q-D Bushings

- Can be reverse mounted.
- Setscrew over keyway except JA.
- Stock metric bores - 25 mm - 100 mm.

## DESIGN AND INSTALLATION SUGGESTIONS

Browning® Gripbelt® "V" Drives are primarily intended for the transmission of power with relatively high speed driving units. Their acceptance by industry covers a broad field of applications including installations on a wide variety of different types of equipment, including speed increasing drives, V-flat drives, quarter-turn drives, multiple shaft drives and conveyors. Many such applications are regularly being designed and installed using stock parts.

Experience has proven that most drive applications fall within the range of the stock drives as covered by the Gripbelt Drive Selection Tables and the Sheave and Belt specifications contained within this catalog. For drives not falling within this category, it is necessary to review and use the Gripbelt Drive Engineering Data. Unusual applications should be referred to Application Engineering.

Regardless of whether drives consist of stock or special items there are certain primary conditions to consider with respect to the design of satisfactory drives. Those most commonly encountered are:

1. Drives should always be installed with provision for center distance adjustment. This is essential, because an adjustment is necessary after the belt has set and seated properly in the groove of the sheave. If centers must be fixed, idlers should be used.
2. If possible, centers should not exceed 3 times the sum of the sheave diameters nor be less than the diameter of the large sheave.
3. If possible, the arc of contact of the belt on the smaller sheave should not be less than 120°.
4. Belt speeds with cast iron sheaves cannot exceed 6500 feet per minute. Another type of drive is usually more desirable for speeds under 1000 feet per minute.
5. Special or dynamic balance may need consideration for belts speeds exceeding 5000 feet per minute.
6. Full consideration and allowance for overload capacity in drives increases belt life and improves operation. Study the Overload Service Factors in this section carefully.
7. Severe temperature can have a major effect on belt life. There should be a full and free circulation of air around the drive. All drives operating in explosive atmospheres should be well grounded and use static conducting belts.

Watch these points particularly when installing drives:

1. Be sure that shafts are parallel and sheaves are in proper alignment. Check after eight hours of operation.
2. Do not drive sheaves on or off shafts. Be sure shaft and keyway are smooth and that bore and key are of correct size. Remove burrs by dressing lightly with finishing file. Wipe shaft, key and bore clean with oil. Tighten screws carefully. Recheck and retighten after eight hours of operation.
3. Belts should never be forced over sheaves. More belts are broken from this cause than from actual failure in service. See Table No. 1.
4. In mounting belts, be sure that the slack in each and every belt is on the same side of the drive. This should be the slack side of the drive.
5. Belt tension should be reasonable. When in operation the tight side of belts should be in a straight line from sheave to sheave and with a slight bow on the slack side. Check belt tension after eight hours of operation. All drives should be inspected periodically to be sure belts are under proper tension and not slipping.

**For more detailed tensioning instructions and an inexpensive tension checker, see page 90.**

6. Do not install new sets of belts in drives where the sheaves have worn grooves. Such sheaves should be replaced with new sheaves to insure a proper fit of the belts in the grooves, thus help eliminate possibility of premature belt failure.
7. Keep belts clean. Do not use belt dressing.
8. When replacing belts on a drive, be sure to replace the entire set with a new set of matched belts. Failure to do this will probably result in premature breakage of new (and probably shorter) belts mixed with old ones.
9. Keep extra belts stored in a cool, dark, dry place.

**CAUTION! Install guards according to local and national codes.**

### Minimum Center Distance Allowance for Belt Installation and Take-Up

Belt No.	Allowance for Installation (in.)				Allowance for Initial Tensioning and Subsequent Take-Up (in.)
	A	B	C	D	All Sections
26 - 35	0.8	1.0	—	—	1
38 - 55	0.8	1.0	1.5	—	1.5
60 - 85	0.8	1.3	1.5	—	2
90 - 112	1	1.3	1.5	—	2.5
120 - 144	1	1.3	1.5	2.0	3
158 - 180	—	1.3	2.0	2.0	3.5
195 - 210	—	1.5	2.0	2.0	4
240	—	1.5	2.0	2.5	4.5
220 - 300	—	1.5	2.0	2.5	5
330 - 390	—	—	2.0	2.5	6
420 and over	—	—	2.3	3	1 1/2% of Belt Length
	<b>3V</b>	<b>5V</b>	<b>8V</b>		<b>All Sections</b>
250 - 475	0.5	—	—	—	1.0
500 - 710	0.8	1	—	—	1.2
750 - 1060	0.8	1	1.5	—	1.5
1120 - 1250	0.8	1	1.5	—	1.8
1320 - 1700	0.8	1	1.5	—	2.2
1800 - 2000	—	1	1.8	—	2.5
2120 - 2240	—	1.2	1.8	—	2.8
2360	—	1.2	1.8	—	3
2500 - 2650	—	1.2	1.8	—	3.2
2800 - 3000	—	1.2	1.8	—	3.5
3150	—	1.2	1.8	—	4.0
3350 - 3550	—	1.5	2	—	4.0
3750	—	—	2	—	4.5
4000 - 5000	—	—	2	—	5.5
5600	—	—	2	—	6.0

## BASIC DRIVE SELECTION PROCEDURE

Selections are based on horsepower ratings for single belt and are not corrected for arc of contact, belt length or ratio. Selections based on a 1.0 service factor. Drive calculations based on motor or smaller sheave operating at 1750 rpm.

Application characteristics: **Low horsepower**

- For single groove low horsepower application (under 3 hp)
- Ideal for fan applications

## FHP (FRACTIONAL HORSEPOWER) V-BELTS

Belt Type	Pitch Dia.	1.25*	1.5	1.75	2.0	2.5	3.0	3.5	4.0	4.5	5.0	-	-
	3L	hp Rating	0.09	0.15	0.23	0.29	0.43	0.55	0.61	0.67	0.73	0.78	-
Belt Type	Pitch Dia.	1.25*	1.5"	2.0"	2.5	3	3.5	4.0	4.5 1.49	5.0	5.5	6.0	-
	4L	hp Rating	0.09	0.14	0.29	0.6	0.88	1.17	1.37	1.49	1.61	1.7	1.78
Belt Type	Pitch Dia.	2.2"	2.5"	3.0"	3.4	3.9	4.4	4.9	5.4	5.9	6.4	6.9	7.4
	5L	hp Rating	0.36	0.45	0.71	1.07	1.52	1.95	2.26	2.39	2.50	2.59	2.68

Application characteristics: **Medium horsepower**

- For industrial applications requiring single or multiple V-belt drives
- Transmits more horsepower and has longer life expectancy than FHP V-belts
- Suited for "clutching" applications

## A, B AND C TYPE V-BELTS

Belt Type	Pitch Dia.	2.00*	2.20*	2.60*	3.00	3.40	3.70	4.00	4.40	4.70	5.00	5.40	5.70	6.00	6.40	7.00	8.00
	A	hp Rating	0.90	1.17	1.69	2.23	2.95	3.40	4.00	4.69	5.20	5.96	6.35	6.83	7.30	7.91	8.81
Belt Type	Pitch Dia.	3.00	3.30*	3.80*	4.20*	4.60*	5.00*	5.40	5.80	6.20	6.60	7.00	7.40	8.00	8.60	9.00	9.40
	B	hp Rating	1.58	2.47	3.34	4.19	5.10	6.16	7.21	8.22	9.22	10.19	11.13	12.06	13.39	14.66	15.48
Belt Type	Pitch Dia.	5.60	7.00*	7.40*	7.80*	8.20*	8.60*	9.00	9.40	9.80	10.20	11.00	12.00	14.00	-	-	-
	C	hp Rating	6.94	12.09	13.62	15.11	16.56	17.96	19.32	20.62	21.88	23.09	25.35	27.86	31.76	-	-

Application characteristics: **Medium/High horsepower**

- For industrial applications requiring single or multiple V-belt drives
- Raw edge, cogged
- Transmits more horsepower than comparable A, B, and C belts
- Raw edge design provides more aggressive gripping with less belt slippage
- Cogged construction allows belt to flex easier around drive sheave and run cooler than non-cogged belts
- Not for use on (clutching) applications because of aggressive grip

## AX, BX AND CX TYPE V-BELTS

Belt Type	Pitch Dia.	2.00*	2.20	2.60	3.00	3.40	3.70	4.00	4.70	5.00	5.40	5.70	6.00	6.40	7.00	8.00	-
	AX	hp Rating	1.24	1.58	2.25	2.90	3.53	3.99	4.46	5.67	6.18	6.84	7.34	7.82	8.45	9.39	10.88
Belt Type	Pitch Dia.	3.00*	3.40*	3.80	4.20	4.60	5.00	5.40	5.80	6.20	6.60	7.00	7.40	8.00	8.60	9.00	9.40
	BX	hp Rating	3.72	4.62	5.50	6.36	7.19	8.08	9.19	10.27	11.34	12.39	13.41	14.42	15.89	17.32	18.23
Belt Type	Pitch Dia.	5.60*	7.00	7.40	7.80	8.20	8.60	9.00	9.40	9.80	10.20	11.00	12.00	14.00	-	-	-
	CX	hp Rating	14.10	18.35	19.49	20.60	21.66	23.14	24.61	26.05	27.44	28.79	31.37	34.32	39.31	-	-

Application characteristics: **High horsepower**

- For industrial applications requiring single or multiple V-belt drives
- Transmits substantially more horsepower than A, AX, B, BX, C and CX, which allows for more compact drive systems (smaller sheave O.D. and/or fewer grooves)
- Raw edge, cogged

## 3VX AND 5VX TYPE V-BELTS

Belt Type	Pitch Dia.	2.15	2.30	2.45	2.60	2.95	3.10	3.30	3.60	4.45	4.70	4.95	5.25	5.95	6.85	7.95	10.55
	3VX	hp Rating	1.37	1.63	1.89	2.15	2.75	3.01	3.34	3.85	5.25	5.65	6.05	6.53	7.63	9.01	10.64
Belt Type	Pitch Dia.	4.30	4.55	4.80	5.10	5.40	5.70	5.90	6.20	6.50	6.70	7.00	7.40	7.90	8.40	9.10	9.50
	5VX	hp Rating	8.23	9.40	10.55	11.93	13.30	14.66	15.56	16.89	18.22	19.10	20.41	22.13	24.26	26.35	29.23

\* Below ARPM minimum recommended pitch diameter.

Note: For speeds not shown on this page, use tables on pages 91-102. Drives must be corrected for loss in arc of contact.

## OVERLOAD SERVICE FACTORS

Load and operating characteristics of both the driving and driven units must be considered thoroughly in the selection of Browning® Gripbelt® Drives. It is essential that all drives be designed for maximum load conditions to be encountered.

Most drives will at some time be overloaded, perhaps only momentarily. It is good practice to have predetermined drive capacity to handle this overload. This predetermined drive capacity helps protect against breakdowns due to premature belt failure. The use of an extra belt will pay for itself many times over by increasing the life of all the belts more than the proportionate cost of the extra belt.

For good design and satisfactory drive life all drives must be selected giving careful consideration to two fundamental conditions:

1. The motor must have greater capacity than the driven unit.
2. The drive must have greater capacity than the motor.

Careful consideration of Overload Service Factors for various types of driven units, drivers, type of starting, frequency of maintenance and other drive conditions is extremely important for satisfactory performance and life.

The following are suggested Overload Service Factors for various typical driven units:

**Table No.1 Suggested Overload Service Factors for Typical Applications**

TYPES OF DRIVEN MACHINES	TYPES OF DRIVING UNITS					
	AC Motors; Normal Torque, Squirrel Cage, Synchronous and Split Phase. DC Motors; Shunt Wound. Multiple Cylinder Internal Combustion Engines.			AC Motors; High Torque, High Slip, Repulsion-Induction, Single Phase, Series Wound and Slip Ring. DC Motors; Series Wound and Compound Wound. Single Cylinder Internal Combustion Engines. Clutches.Line Shafts.		
	Intermittent Service (3-5 Hours Daily or Seasonal)	Normal Service (8-10 Hours Daily)	Continuous Service (16-24 Hours Daily)	Intermittent Service (3-5 Hours Daily or Seasonal)	Normal Service (8-10 Hours Daily)	Continuous Service (16-24 Hours Daily)
Agitators for Liquids Blowers and Exhausters Centrifugal Pumps and Compressors Fans up to 10 hp Light Duty Conveyors	1	1.1	1.2	1.1	1.2	1.3
Belt Conveyors for Sand, Grain, etc. Dough Mixers Fans Over 10 hp Generators Line Shafts Laundry Machinery Machine Tools Punches-Presses-Shears Printing Machinery Positive Displacement Rotary Pumps Revolving and Vibrating Screens Speed Reducers, All Types	1.1	1.2	1.3	1.2	1.3	1.4
Brick Machinery Bucket Elevators Exciters Piston Compressors Conveyors (Drag-Pan-Screw) Hammer Mills Paper Mill Beaters Piston Pumps Positive Displacement Blowers Pulverizers Saw Mill and Woodworking Machinery Textile Machinery	1.2	1.3	1.4	1.4	1.5	1.6
Crushers (Gyratory-Jaw-Roll) Mills (Ball-Rod-Tube) Hoists Rubber Calenders-Extruders-Mills	1.3	1.4	1.5	1.5	1.6	1.8

A minimum Service Factor of 2.0 is suggested for equipment subject to choking.

Service factor should be increased by 0.2 on drive units with an increaser drive speed of 2200 rpm or lower when using a 1750 rpm motor. This is a speed-up ratio of 1.25 or less. For speed increaser drives or speed-up drives greater than 2200 rpm, the recommendation is to use a 2.0 service factor.

**CAUTION!** Drives requiring high Overload Service Factors, such as crushing machinery, certain reciprocating compressors, etc. subjected to heavy shock load without suitable fly wheels, may need heavy duty web type sheaves rather than standard arm type. For any such application, consult Application Engineering.

## Datum System

In December, 1987, RMA/MPTA adopted Standard IP20-1988. This standard supersedes IP20-1977 and affected the A, B, C, and D belts and sheaves. Those products in this catalog are in accordance with IP20-1988 which incorporates the Datum Diameter System.

The Datum System specifies the Datum Diameter as the effective diameter for determining the pitch length of the belt for center distance calculation. In this catalog, Datum Diameter (D.D.) is now listed for the A, B, C, and D sheaves and is equal to the old Pitch Diameter (P.D.) shown in previous catalogs.

## Belt Velocity

Belt velocity is not needed for calculation of drives, as the horsepower ratings shown are based on the rpm of the sheave. If belt velocity is desired for any reason, use the formula:

**Belt Velocity in Feet per Minute (rpm) =**

**D.D. or P.D. of Sheave × .2618 × Speed of Sheave (rpm)**

Cast Iron Sheaves must not be used beyond 6500 fpm belt speed. Since the majority of stock sheaves are made of cast iron, we list no ratings above 6500 fpm.

Some types of belts lose ratings before they reach 6500 fpm and other types continue to increase beyond 6500 fpm. The Basic Rating Tables and the Drive Selection Tables reflect these variations.

## Special Balance

Functionally, speeds up to 6500 fpm are acceptable; however, in applications where vibration requirements are critical, special balancing (usually dynamic) for speeds above 5000 fpm may be considered. Factors to be considered for special balance requirements are: rigidity of drive mounting, whether noise created by a level of vibration would be prohibitive, etc. Many drives are in service running at speeds up to 6500 FPM without special balancing.

## Center Distance and Belt Length

The belt lengths listed in the Drive Selection Tables can be interpolated for belt size, center distance and "F" factor from the shortest to the longest shown.

## Interpolation

For every inch of belt length difference there is approximately 1/2 inch center distance change. All belt numbers reflect a relation if it is pitch length, outside length or inside length. An A26 belt is 2" longer than an A24 belt; a B105 belt is 15" longer than a B90 belt; a 3V335 belt is 8.5" longer than a 3V250 belt, etc.

Interpolation example:

If an A128 belt gives 50.0" C.D. with 1.12 "F" factor and an A96 gives 34.0 C.D. with 1.05 "F" factor, then an A112 belt gives 42.0 C.D. with 1.09 "F" factor.

If a 5V1200 belt gives 83.1" C.D. with 1.07 "F" factor and a 5V1600 gives 63.1 C.D. with 1.03 "F" factor, then a 5V1800 belt gives 73.1 C.D. with 1.05 "F" factor.

Center distance and belt lengths determined by interpolation are usually close enough as all drives should provide for take-up as indicated on page 85. If closer calculation is necessary for any reason use the following formula:

$$L = 2C + 1.57(D + d) + \frac{(D - d)^2}{4C}$$

where:

- L = Pitch Length of Belt
- C = Center Distance
- D = Datum or Pitch Diameter of Large Sheave
- d = Datum or Pitch Diameter of Small Sheave

## Driven Speed Variations

All V-Belt Drives will vary slightly from the speeds shown in the Drive Selection Tables. These variations are due to different motor speeds depending on load, changing frequencies (on A.C. Motors) or voltage (on D.C. Motors), varying tensions and resulting slip, and allowable manufacturing tolerances in belts and sheaves. Also, actual sheave pitch diameters and actual belt pitch lines have been changed slightly over the years by all manufacturers but catalog data has not been changed to reflect this.

The drive selection tables are still very usable and ratios still can be calculated from published sheave pitch or datum diameters since the variations are small and historically have caused very few problems through out the vast range of V-Belt Drive applications. A good rule of thumb is to design a belt drive based on ±3% speed variation.

In the few instances where very close speed tolerances are required, contact Application Engineering for assistance or use the Browning® Edge™ Selection Program.

## Speed-Up, Quarter-Turn, and V-Flat Drives

These drives occur infrequently and should be referred to Application Engineering for special design considerations.

## Belt Section Selection Chart

Table No.1

hp	Belt Section				
	A	AX	B	BX	C
1/2	A	AX			
3/4	A	AX			
1	A	AX			
1 1/2	A	AX			
2	A	AX			
3	AX	A	BX		
5	BX	AX	B		A
7 1/2	BX	B	5VX	3VX	3VX
10	5VX,BX	B	3VX	AX	
15	5VX,BX	B	3VX	AX	
20	5VX	BX	B	3VX	
25	5VX	BX	B	3VX	
30	5VX	BX	B	3VX	
40	5VX,5V	BX	B		
50	5VX,5V	BX	B	CX	
60	5VX,5V	BX	B	CX	
75	5VX,5V	CX	BX	C	
100	5VX,5V	CX	C		
125	5VX,5V	CX	C		
150	5VX,5V	CX	C		
200	5VX,5V	CX			
250	5VX,5V	CX			

The best drive will usually be found by using Belt Section from the first column. If, for any reason, such as sheave shortage, this drive is not suitable, go to the next column.

\*AX\* drives are found in the "A" Drive Selection Tables; "BX" in the "B" Tables, etc.



This and the other information on this page is included for technical support in figuring non-standard drives.

### Correction Factor for Belt Length

Longer belts have greater horsepower ratings because of less frequent flexure around sheaves.

Multiply H. P. ratings by appropriate factor from table below to get the final corrected horsepower.

**Table No.1**

Nominal Length	A	B	C	Nominal Length	A	B	C	D	E
26	.81	-	-	90	1.06	1.00	.91	-	-
31	.84	-	-	93	-	1.01	-	-	-
32	.85	-	-	96	1.08	1.02	.92	-	-
33	.86	-	-	97	-	1.02	-	-	-
34	.86	-	-	99	-	1.02	-	-	-
35	.87	.81	-	100	-	1.03	-	-	-
36	.87	-	-	103	-	1.03	-	-	-
37	.88	-	-	105	1.10	1.04	.94	-	-
38	.88	.83	-	108	-	1.04	-	-	-
42	.90	.85	-	109	-	-	.94	-	-
43	.90	-	-	110	1.11	-	-	-	-
46	.92	.87	-	112	1.11	1.05	.95	-	-
48	.93	.88	-	115	-	-	.96	-	-
50	-	.89	-	116	-	1.06	-	-	-
51	.94	.89	.80	120	1.13	1.07	.97	.86	-
52	-	.89	-	124	-	1.07	-	.87	-
53	.95	.90	-	128	1.14	1.08	.98	-	-
54	.95	.90	-	133	-	1.08	-	-	-
55	.96	.90	-	136	1.15	1.09	.99	-	-
56	.96	.90	-	144	1.16	1.11	1.00	.90	.88
58	.97	.91	-	150	-	1.12	1.01	-	-
59	-	.91	-	158	1.17	1.13	1.02	.92	-
60	.98	.92	.82	162	-	1.13	1.03	.92	-
61	-	.92	-	173	1.18	1.15	1.04	.93	-
62	.99	.93	-	180	1.19	1.16	1.05	.94	.91
63	-	.93	-	195	-	1.18	1.07	.96	.92
64	.99	.93	-	210	-	1.19	1.08	.96	.94
65	-	.94	-	225	-	1.20	1.09	.98	.95
66	1.00	.94	-	240	-	1.22	1.11	1.00	.96
67	-	.94	-	255	-	1.23	1.12	1.01	-
68	1.00	.95	.85	270	-	1.25	1.14	1.03	.99
70	1.01	.95	-	285	-	1.26	1.15	1.04	-
71	1.01	.95	-	300	-	1.27	1.16	1.05	1.01
75	1.02	.97	.87	315	-	1.28	1.17	1.06	-
77	-	.98	-	330	-	-	1.19	1.07	1.03
78	1.03	.98	-	345	-	-	1.20	1.08	-
79	-	.98	-	360	-	1.31	1.21	1.09	1.05
80	1.04	.98	-	390	-	-	1.23	1.11	1.07
81	-	.98	.89	420	-	-	1.24	1.12	1.09
82	-	.99	-	480	-	-	-	1.16	1.12
83	-	.99	-	540	-	-	-	1.18	1.14
85	1.05	.99	.90	600	-	-	-	1.20	1.17
88	-	1.00	-	-	-	-	-	-	-

**Table No.2**

Belt Length	Cross Section			Belt Length	Cross Section		
	3V	5V	8V		3V	5V	8V
25.0	.83	-	-	112.0	1.11	.98	.88
26.5	.84	-	-	118.0	1.12	.99	.89
28.0	.85	-	-	125.0	1.13	1.00	.90
30.0	.86	-	-	132.0	1.14	1.01	.91
31.5	.87	-	-	140.0	1.15	1.02	.92
33.5	.88	-	-	150.0	-	1.03	.93
35.5	.89	-	-	160.0	-	1.04	.94
37.5	.91	-	-	170.0	-	1.05	.95
40.0	.92	-	-	180.0	-	1.06	.95
42.5	.93	-	-	190.0	-	1.07	.96
45.0	.94	-	-	200.0	-	1.08	.97
47.5	.95	-	-	212.0	-	1.09	.98
50.0	.96	.85	-	224.0	-	1.09	.98
53.0	.97	.86	-	236.0	-	1.10	.99
56.0	.98	.87	-	250.0	-	1.11	1.00
60.0	.99	.88	-	265.0	-	1.12	1.01
63.0	1.00	.89	-	280.0	-	1.13	1.02
67.0	1.01	.90	-	300.0	-	1.14	1.03
71.0	1.02	.91	-	315.0	-	1.15	1.03
75.0	1.03	.92	-	335.0	-	1.16	1.04
80.0	1.04	.93	-	355.0	-	1.17	1.05
85.0	1.06	.94	-	375.0	-	-	1.06
90.0	1.07	.95	-	400.0	-	-	1.07
95.0	1.08	.96	-	425.0	-	-	1.08
100.0	1.09	.96	.87	450.0	-	-	1.09
106.0	1.10	.97	.88	-	-	-	-

### Correction Factor for Loss in Arc of Contact

The loss of arc of contact from 180° for different drives can be determined in the following manner:

$$\text{Loss in Arc of Contact (in degrees)} = \frac{(D - d) 57}{C}$$

The Correction Factors for loss in arc of contact in degrees are;

**Table No.3**

Loss in Arc of Contact	Correction Factor	Loss in Arc of Contact	Correction Factor
0°	1.00	50°	.86
5°	.99	55°	.84
10°	.98	60°	.83
15°	.96	65°	.81
20°	.95	70°	.79
25°	.93	75°	.76
30°	.92	80°	.74
35°	.90	85°	.71
40°	.89	90°	.69
45°	.87		

**Table No.4 (in.)**

Belt Selection	Nominal Belt Size	Add to P.D. to get O.D.	Minimum Recommended Pitch Diameter*	C	D
A	1/2 x 5/16	.25	3.00	3/8	5/8
B	21/32 x 13/32	.35	5.40	1/2	3/4
C	7/8 x 17/32	.40	9.00	11/16	1
D	1 1/4 x 3/4	.64	13.00	7/8	1 7/16
E	1 1/2 x 29/32	.82	21.00	1 1/8	1 3/4
3V	3/8 x 5/16	.05	2.60	11/32	13/32
5V	5/8 x 7/16	.10	7.00	1/2	11/16
8V	1 x 7/8	.20	12.50	3/4	1 1/8

\*The minimum recommended pitch diameters listed above are ARPM and MPTA Standards recommendations. Many sheaves with diameters smaller than these recommendations are made and used. If a rating for a "sub-minimum diameter" sheave is published in the selection tables and the drive is properly installed, it should give the same theoretical life as a drive using sheave diameters equal to or greater than the minimums shown above.

$$1 \text{ hp} = 54" \text{ in lbs. @ 1160 rpm}$$

$$1 \text{ hp} = 36" \text{ in lbs. @ 1750 rpm}$$

$$\text{hp} = \frac{\text{FORCE} \times \text{FPM}}{33,000}$$

$$\text{hp} = \frac{"T \text{ in lbs."} \times \text{rpm}}{63,025}$$

$$\text{hp} = \frac{"T \text{ ft lbs."} \times \text{rpm}}{5,252}$$

$$"T \text{ in lbs."} = \frac{63,025 \times \text{hp}}{\text{rpm}}$$

$$"T \text{ ft lbs."} = \frac{5,252 \times \text{hp}}{\text{rpm}}$$

$$\text{FPM} = .2618 \times \text{DIA.} \times \text{rpm}$$

$$\text{rpm} = \frac{63,025 \times \text{hp}}{\text{TORQUE}}$$

$$T = \text{FORCE} \times \text{LEVER ARM}$$

$$F = \frac{\text{TORQUE}}{\text{RADIUS}}$$

$$\text{rpm} = \frac{\text{FPM}}{.2618 \times \text{DIA.}}$$

$$\text{OL} = \frac{2TK}{D}$$

$$K = 1.0 \text{ for Chain Drives}$$

$$1.25 \text{ for Gear Drives}$$

$$1.25 \text{ for Gearbelt Drives}$$

$$1.50 \text{ for V-Belt Drives}$$

$$2.50 \text{ for Flat Belt Drives}$$

$$\text{LINEAL SHAFT EXPANSION}$$

$$= .0000063 \times \text{length in inches}$$

$$\times \text{temperature inc.}$$

$$\text{in degrees F}$$

$$\text{KW} = \text{hp} \times .7457$$

$$\text{IN.} = \text{MM}/25.4$$

$$\text{TEMP } ^\circ\text{C} = (^\circ\text{F}-32) .556$$

$$\text{LBS} = \text{Kg} \times 2.205$$

# Gripbelt® Drive Engineering Data

## TENSIONING V-BELT DRIVES

General rules of tensioning.

1. Ideal tension is the lowest tension at which the belt will not slip under peak load conditions.
2. Check tension frequently during the first 24 - 48 hours of operation.
3. Over tensioning shortens belt and bearing life.
4. Keep belts free from foreign material which may cause slip.
5. Make V-drive inspection on a periodic basis. Tension when slipping. Never apply belt dressing as this will damage the belt and cause early failure.

$$\text{DEFLECTION} = \frac{\text{BELT SPAN}}{64}$$

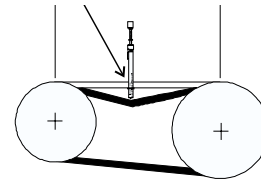

## TENSION MEASUREMENT PROCEDURE

1. Measure the belt span (see sketch).
2. Position bottom of the large o-ring on the span scale at the measured belt span.
3. Set the small o-ring on the deflection force scale to zero.
4. Place the tension checker squarely on one belt at the center of the belt span. Apply a force on the plunger and perpendicular to the belt span until the bottom of the large o-ring is even with the top of the next belt or with the bottom of a straight edge laid across the sheaves.
5. Remove the tension checker and read the force applied from the bottom of the small o-ring on the deflection force scale.
6. Compare the force you have applied with the values given in Table No.1. The force should be between the minimum and maximum shown. The maximum value is shown for "New Belt" and new belts should be tensioned at this value to allow for expected tension loss. Used belts should be maintained at the minimum value as indicated in Table No.1.

Note: The ratio of deflection to belt span is 1:64.



Part Number  
"Belt Tension Checker"

Table No.1 Sheave Diameter - In.

Deflection Force - Lbs

Cross Section	Smallest Sheave Diameter Range	rpm Range	Belt Deflection Force			
			Super Gripbelt® Belts and Unnotched Gripbands		Gripnotch® Belts and Notched Gripband Belts	
			Used Belt	New Belt	Used Belt	New Belt
A, AX	3.0 - 3.6	1000-2500	3.7	5.5	4.1	6.1
		2501-4000	2.8	4.2	3.4	5.0
	3.8 - 4.8	1000-2500	4.5	6.8	5.0	7.4
		2501-4000	3.8	5.7	4.3	6.4
B, BX	5.0 - 7.0	1000-2500	5.4	8.0	5.7	9.4
		2501-4000	4.7	7.0	5.1	7.6
	3.4 - 4.2	860-2500			4.9	7.2
		2501-4000			4.2	6.2
C, CX	4.4 - 5.6	860-2500	5.3	7.9	7.1	10.5
		2501-4000	4.5	6.7	7.1	9.1
	5.8 - 8.6	860-2500	6.3	9.4	8.5	12.6
		2501-4000	6.0	8.9	7.3	10.9
D	7.0 - 9.0	500-1740	11.5	17.0	14.7	21.8
		1741-3000	9.4	13.8	11.9	17.5
	9.5 - 16.0	500-1740	14.1	21.0	15.9	23.5
		1741-3000	12.5	18.5	14.6	21.6
3V, 3VX	12.0 - 16.0	200-850	24.9	37.0		
		851-1500	21.2	31.3		
	18.0 - 20.0	200-850	30.4	45.2		
		851-1500	25.6	38.0		
5V, 5VX	2.2 - 2.4	1000-2500			3.3	4.9
		2501-4000			2.9	4.3
	2.65 - 3.65	1000-2500	3.6	5.1	4.2	6.2
		2501-4000	3.0	4.4	3.8	5.6
8V	4.12 - 6.90	1000-2500	4.9	7.3	5.3	7.9
		2501-4000	4.4	6.6	4.9	7.3
	4.4 - 6.7	500-1749			10.2	15.2
		1750-3000			8.8	13.2
		3001-4000			5.6	8.5
8V	7.1 - 10.9	500-1740	12.7	18.9	14.8	22.1
		1741-3000	11.2	16.7	13.7	20.1
	11.8 - 16.0	500-1740	15.5	23.4	17.1	25.5
		1741-3000	14.6	21.8	16.8	25.0
8V	12.5 - 17.0	200-850	33.0	49.3		
		851-1500	26.8	39.9		
	18.0 - 22.4	200-850	39.6	59.2		
		851 - 1500	35.3	52.7		

Table No.2 FHP Belts Deflection Force

Cross Section	Small P.D. Range	Lbs.	
		Min.	Max.
3L	1.25 - 1.75	1/2	5/8
	2.00 - 2.25	5/8	7/8
	2.50 - 3.00	3/4	1 1/8
4L	2.1 - 2.8	1 1/8	1 5/8
	3.0 - 3.5	1 1/2	2 1/8
	3.7 - 5.0	1 7/8	2 5/8
5L	3.0 - 4.2	2	2 7/8
	4.5 - 5.2	2 3/8	3 3/8

The above method of tensioning belt drives is to be used when a drive has been selected in accordance with the suggestions listed in the drive selection tables of the HVAC catalog. For drives with service factor greater than 1.5, consult Application Engineering. For exact tension calculations use the EDGE™ Selection Program.



A

## A GRIPBELT® BELTS HORSEPOWER TABLES "A" SUPER GRIPBELT BELTS

Table No.1 ("Drive Ratio Correction" Must Be Added to Ratings Listed Below)

rpm of Smaller Sheave	SHEAVE DATUM DIAMETERS (in.)																		
	2.00	2.10	2.20	2.40	2.60	2.80	3.00	3.20	3.40	3.50	3.70	3.80	4.00	4.20	4.40	4.50	4.70	4.80	5.00
1160	**	**	**	**	**	**	1.68	1.94	2.19	2.32	2.57	2.69	2.94	3.19	3.43	3.55	3.80	3.92	4.16
1450	**	**	**	1.27	1.49	1.71	1.96	2.27	2.58	2.73	3.04	3.19	3.49	3.78	4.08	4.23	4.52	4.66	4.95
1750	0.90	1.03	1.17	1.43	1.69	1.95	2.23	2.59	2.95	3.13	3.48	3.66	4.00	4.35	4.69	4.86	5.20	5.36	5.69
2900	1.10	1.30	1.50	1.90	2.28	2.66	3.03	3.49	4.02	4.28	4.79	5.04	5.54	6.02	6.50	6.73	7.19	7.41	7.85
3500	1.14	1.37	1.60	2.05	2.49	2.92	3.34	3.78	4.37	4.66	5.22	5.50	6.04	6.56	7.07	7.32	7.80	8.03	8.49
600	**	**	**	**	**	**	**	**	**	**	**	**	**	**	**	**	**	**	**
800	**	**	**	**	**	**	**	**	**	**	**	**	**	**	**	2.55	2.64	2.81	2.90
1000	**	**	**	**	**	**	**	**	**	**	2.07	2.29	2.40	2.62	2.84	3.05	3.16	3.37	3.48
1200	**	**	**	**	**	**	1.72	1.99	2.25	2.38	2.63	2.76	3.02	3.27	3.53	3.65	3.90	4.02	4.27
1400	**	**	**	**	1.46	1.67	1.92	2.22	2.52	2.66	2.96	3.11	3.40	3.69	3.97	4.11	4.40	4.54	4.82
1600	**	**	1.11	1.35	1.59	1.83	2.10	2.44	2.77	2.93	3.26	3.43	3.75	4.07	4.39	4.55	4.86	5.02	5.33
1800	0.91	1.05	1.19	1.45	1.72	1.98	2.27	2.64	3.00	3.19	3.55	3.73	4.09	4.44	4.79	4.96	5.30	5.47	5.81
2000	0.96	1.11	1.26	1.55	1.84	2.13	2.42	2.82	3.22	3.42	3.82	4.01	4.40	4.78	5.16	5.34	5.71	5.90	6.26
2200	1.00	1.16	1.32	1.64	1.95	2.26	2.57	3.00	3.43	3.64	4.07	4.27	4.69	5.10	5.50	5.70	6.10	6.29	6.68
2400	1.03	1.21	1.38	1.72	2.06	2.39	2.71	3.16	3.62	3.85	4.30	4.52	4.96	5.39	5.82	6.03	6.45	6.65	7.06
2600	1.06	1.25	1.43	1.80	2.15	2.50	2.85	3.30	3.79	4.03	4.51	4.74	5.21	5.66	6.11	6.33	6.77	6.98	7.40
2800	1.09	1.28	1.48	1.86	2.24	2.61	2.97	3.43	3.95	4.20	4.70	4.95	5.43	5.91	6.38	6.60	7.06	7.28	7.71
3000	1.11	1.32	1.52	1.93	2.32	2.71	3.09	3.55	4.09	4.35	4.87	5.13	5.64	6.13	6.61	6.85	7.31	7.54	7.99
3200	1.12	1.34	1.56	1.98	2.40	2.80	3.20	3.65	4.21	4.49	5.03	5.29	5.82	6.32	6.82	7.06	7.53	7.77	8.22
3400	1.13	1.36	1.59	2.03	2.46	2.88	3.29	3.74	4.32	4.60	5.16	5.44	5.97	6.49	7.00	7.24	7.72	7.95	8.41
3600	1.14	1.38	1.61	2.07	2.52	2.96	3.38	3.81	4.41	4.70	5.28	5.56	6.10	6.63	7.14	7.39	7.87	8.11	8.56
3800	1.14	1.39	1.63	2.11	2.57	3.02	3.46	3.88	4.48	4.78	5.37	5.65	6.21	6.74	7.26	7.50	7.98	8.22	8.66
4000	1.14	1.39	1.64	2.13	2.61	3.07	3.52	3.95	4.54	4.84	5.44	5.73	6.29	6.82	7.34	7.58	8.06	8.28	8.72
4400	1.11	1.38	1.65	2.17	2.67	3.15	3.62	4.06	4.59	4.91	5.51	5.80	6.36	6.89	7.39	7.63	8.08	8.29	8.69
4800	1.07	1.36	1.64	2.18	2.70	3.20	3.67	4.11	4.57	4.88	5.49	5.77	6.32	6.83	7.30	7.52	7.93	8.12	8.46
5200	1.01	1.31	1.60	2.16	2.69	3.19	3.67	4.11	4.51	4.77	5.36	5.64	6.16	6.63	7.05	7.24	7.59	-	-
5600	0.93	1.23	1.53	2.11	2.65	3.15	3.62	4.04	4.43	4.60	5.13	5.39	5.86	6.28	6.64	-	-	-	-
6000	0.82	1.14	1.44	2.02	2.56	3.06	3.51	3.91	4.27	4.43	4.78	5.02	5.43	-	-	-	-	-	-
6500	0.66	0.98	1.29	1.87	2.40	2.88	3.30	3.66	3.96	4.08	4.28	4.37	-	-	-	-	-	-	-
7000	0.46	0.79	1.09	1.66	2.17	2.62	2.99	3.29	3.51	3.60	-	-	-	-	-	-	-	-	-
7500	0.23	0.55	0.85	1.40	1.87	2.27	2.58	2.80	-	-	-	-	-	-	-	-	-	-	-
8000	-	0.27	0.56	1.07	1.50	1.83	2.06	-	-	-	-	-	-	-	-	-	-	-	-

## "AX" GRIPNOTCH® BELTS

Table No.2 ("Drive Ratio Correction" Must Be Added to Ratings Listed Below)

rpm of Smaller Sheave	SHEAVE DATUM DIAMETERS (in.)																		
	2.00	2.10	2.20	2.40	2.60	2.80	3.00	3.20	3.40	3.50	3.70	3.80	4.00	4.20	4.40	4.50	4.70	4.80	5.00
1160	**	**	**	**	**	**	2.22	2.45	2.67	2.79	3.01	3.12	3.34	3.56	3.78	3.88	4.10	4.21	4.45
1450	**	**	**	1.73	2.01	2.29	2.57	2.85	3.12	3.25	3.52	3.65	3.91	4.17	4.45	4.60	4.89	5.04	5.33
1750	1.24	1.41	1.58	1.92	2.25	2.58	2.90	3.22	3.53	3.68	3.99	4.14	4.46	4.81	5.15	5.33	5.67	5.84	6.18
2900	1.42	1.67	1.92	2.42	2.90	3.37	3.83	4.28	4.81	5.08	5.61	5.87	6.38	6.89	7.39	7.63	8.12	8.36	8.83
3500	1.41	1.70	1.98	2.54	3.09	3.62	4.14	4.76	5.38	5.68	6.27	6.57	7.14	7.71	8.25	8.52	9.05	9.31	9.81
600	**	**	**	**	**	**	**	**	**	**	**	**	**	**	**	**	**	**	**
800	**	**	**	**	**	**	**	**	**	**	**	**	**	**	**	2.86	2.94	3.10	3.18
1000	**	**	**	**	**	**	**	**	**	2.51	2.70	2.80	3.00	3.19	3.39	3.48	3.67	3.76	3.95
1200	**	**	**	**	**	**	2.27	2.50	2.74	2.85	3.08	3.20	3.42	3.65	3.87	3.98	4.20	4.33	4.58
1400	**	**	**	**	1.97	2.24	2.51	2.78	3.04	3.18	3.43	3.56	3.82	4.07	4.33	4.47	4.76	4.90	5.18
1600	**	**	1.51	1.83	2.14	2.44	2.74	3.04	3.33	3.47	3.76	3.90	4.18	4.48	4.81	4.97	5.29	5.45	5.76
1800	1.25	1.43	1.60	1.95	2.29	2.62	2.95	3.27	3.59	3.75	4.06	4.22	4.55	4.91	5.27	5.44	5.79	5.97	6.31
2000	1.30	1.49	1.68	2.06	2.43	2.79	3.14	3.49	3.84	4.01	4.35	4.53	4.93	5.32	5.70	5.89	6.27	6.46	6.83
2200	1.34	1.55	1.75	2.16	2.55	2.94	3.32	3.70	4.07	4.25	4.65	4.86	5.28	5.70	6.12	6.32	6.73	6.93	7.33
2400	1.37	1.59	1.81	2.24	2.66	3.08	3.48	3.88	4.27	4.48	4.94	5.17	5.62	6.07	6.51	6.73	7.16	7.37	7.79
2600	1.40	1.63	1.86	2.32	2.77	3.20	3.63	4.05	4.48	4.73	5.22	5.46	5.94	6.41	6.88	7.11	7.56	7.79	8.23
2800	1.41	1.66	1.90	2.39	2.86	3.32	3.77	4.21	4.71	4.97	5.48	5.74	6.24	6.74	7.22	7.46	7.94	8.17	8.64
3000	1.42	1.68	1.94	2.44	2.94	3.42	3.89	4.36	4.92	5.19	5.73	6.00	6.52	7.04	7.55	7.80	8.29	8.54	9.01
3200	1.42	1.69	1.96	2.49	3.01	3.51	4.00	4.53	5.11	5.40	5.96	6.24	6.79	7.32	7.85	8.11	8.62	8.87	9.36
3400	1.41	1.70	1.98	2.53	3.06	3.59	4.09	4.69	5.29	5.59	6.17	6.46	7.03	7.58	8.12	8.39	8.91	9.17	9.67
3600	1.40	1.70	1.99	2.56	3.11	3.65	4.19	4.83	5.46	5.77	6.37	6.67	7.25	7.82	8.38	8.65	9.18	9.44	9.95
3800	1.38	1.69	1.99	2.58	3.15	3.70	4.30	4.97	5.61	5.93	6.55	6.86	7.45	8.04	8.60	8.88	9.42	9.68	10.19
4000	1.35	1.67	1.98	2.59	3.18	3.76	4.40	5.09	5.75	6.08	6.71	7.03	7.64	8.23	8.80	9.08	9.62	9.88	10.40
4400	1.28	1.61	1.94	2.58	3.22	3.84	4.57	5.28	5.98	6.32	6.98	7.30	7.93	8.54	9.11	9.39	9.93	10.19	10.69
4800	1.18	1.53	1.87	2.57	3.24	3.91	4.68	5.43	6.15	6.50	7.18	7.50	8.14	8.74	9.31	9.59	10.11	10.36	10.83
5200	1.05	1.43	1.80	2.52	3.21	3.95	4.75	5.52	6.25	6.61	7.29	7.62	8.24	8.84	9.39	9.65	10.14	-	-
5600	0.92	1.32	1.70	2.44	3.15	3.95	4.77	5.55	6.29	6.64	7.32	7.64	8.25	8.81	9.33	-	-	-	-
6000	0.77	1.18	1.57	2.33	3.06	3.90	4.73	5.51	6.25	6.60	7.26	7.57	8.15	-	-	-	-	-	-
6500	0.55	0.96	1.37	2.15	2.89	3.77	4.60	5.38	6.09	6.43	7.05	7.33	-	-	-	-	-	-	-
7000	0.29	0.71	1.13	1.91	2.68	3.57	4.39	5.14	5.81	6.12	-	-	-	-	-	-	-	-	-
7500	-	0.42	0.83	1.61	2.41	3.28	4.07	4.78	-	-	-	-	-	-	-	-	-	-	-
8000	-	0.08	0.49	1.25	2.06	2.91	3.66	-	-	-	-	-	-	-	-	-	-	-	-

\*\* Belt Speeds are very low, other types of drives should be considered; consult Application Engineering.



# B GRIPBELT® BELTS HORSEPOWER TABLES

## "B" SUPER GRIPBELT BELTS

**Table No.1 ("Drive Ratio Correction" Must Be Added to Ratings Listed Below)**

rpm of Smaller Sheave	SHEAVE DATUM DIAMETERS (in.)																		
	3.00	3.20	3.40	3.60	3.80	4.00	4.20	4.40	4.60	4.80	5.00	5.20	5.40	5.60	5.80	6.00	6.20	6.40	6.60
1450	1.49	1.88	2.26	2.63	3.01	3.37	3.74	4.10	4.55	5.01	5.47	5.93	6.38	6.82	7.27	7.71	8.14	8.58	9.00
1750	1.58	2.03	2.47	2.91	3.34	3.77	4.19	4.61	5.10	5.64	6.16	6.69	7.21	7.72	8.22	8.72	9.22	9.71	10.19
2900	1.54	2.19	2.82	3.45	4.06	4.65	5.23	5.80	6.35	6.99	7.70	8.38	9.04	9.69	10.31	10.92	11.50	12.06	12.60
3500	1.28	2.01	2.72	3.40	4.06	4.70	5.32	5.92	6.48	7.03	7.69	8.38	9.04	9.67	10.26	10.81	11.34	11.82	12.27
400	**	**	**	**	**	**	**	**	**	**	**	**	**	**	**	**	**	**	**
600	**	**	**	**	**	**	**	**	**	**	**	**	**	**	**	3.71	3.92	4.13	4.35
800	**	**	**	**	**	**	**	**	2.73	3.00	3.28	3.56	3.84	4.12	4.39	4.67	4.94	5.21	5.48
1000	**	**	**	2.11	2.39	2.66	2.93	3.19	3.53	3.87	4.21	4.55	4.88	5.21	5.54	5.87	6.20	6.53	6.85
1200	1.39	1.72	2.04	2.36	2.68	3.00	3.31	3.62	4.01	4.41	4.80	5.19	5.58	5.97	6.35	6.73	7.11	7.49	7.86
1400	1.48	1.85	2.22	2.58	2.94	3.30	3.66	4.01	4.45	4.90	5.34	5.79	6.23	6.66	7.09	7.52	7.95	8.37	8.79
1600	1.54	1.96	2.37	2.78	3.18	3.58	3.97	4.36	4.84	5.34	5.83	6.32	6.81	7.29	7.76	8.24	8.70	9.16	9.62
1800	1.59	2.05	2.50	2.95	3.39	3.82	4.26	4.68	5.18	5.73	6.27	6.80	7.33	7.85	8.37	8.88	9.38	9.88	10.37
2000	1.62	2.12	2.61	3.09	3.57	4.04	4.51	4.97	5.49	6.07	6.65	7.23	7.79	8.35	8.90	9.44	9.97	10.50	11.01
2200	1.63	2.17	2.69	3.21	3.72	4.23	4.73	5.22	5.74	6.37	6.98	7.59	8.19	8.78	9.35	9.92	10.48	11.02	11.56
2400	1.62	2.20	2.76	3.31	3.85	4.39	4.91	5.43	5.95	6.61	7.26	7.90	8.52	9.13	9.73	10.32	10.89	11.45	12.00
2600	1.60	2.21	2.80	3.38	3.96	4.52	5.07	5.61	6.13	6.81	7.48	8.14	8.78	9.41	10.03	10.63	11.21	11.78	12.33
2800	1.56	2.20	2.82	3.43	4.03	4.61	5.19	5.74	6.29	6.94	7.64	8.32	8.98	9.62	10.24	10.85	11.43	12.00	12.54
3000	1.50	2.17	2.82	3.46	4.08	4.68	5.27	5.84	6.40	7.03	7.74	8.43	9.09	9.74	10.36	10.97	11.55	12.10	12.63
3200	1.43	2.12	2.80	3.45	4.09	4.72	5.32	5.90	6.47	7.05	7.77	8.46	9.13	9.78	10.39	10.99	11.55	12.08	12.59
3400	1.34	2.05	2.75	3.43	4.08	4.72	5.33	5.92	6.49	7.04	7.74	8.43	9.09	9.73	10.33	10.90	11.44	11.94	12.41
3600	1.23	1.96	2.68	3.37	4.04	4.68	5.30	5.90	6.46	7.00	7.63	8.32	8.97	9.58	10.16	10.70	11.20	11.67	12.09
3800	1.10	1.85	2.58	3.29	3.97	4.62	5.24	5.83	6.39	6.92	7.46	8.13	8.75	9.34	9.88	10.39	10.84	11.26	-
4000	0.95	1.72	2.47	3.18	3.86	4.51	5.13	5.71	6.26	6.77	7.25	7.85	8.45	9.00	9.50	9.95	10.35	-	-
4200	0.78	1.57	2.32	3.04	3.72	4.37	4.97	5.54	6.07	6.56	7.01	7.49	8.05	8.55	9.00	-	-	-	-
4400	0.60	1.39	2.15	2.87	3.55	4.18	4.78	5.33	5.84	6.29	6.71	7.07	7.55	7.99	-	-	-	-	-
4600	0.39	1.19	1.95	2.67	3.34	3.96	4.54	5.06	5.54	5.96	6.33	6.64	-	-	-	-	-	-	-
4800	0.16	0.97	1.72	2.43	3.09	3.69	4.25	4.74	5.18	5.56	5.88	-	-	-	-	-	-	-	-
5000	-	0.72	1.47	2.16	2.80	3.39	3.91	4.37	4.76	5.09	-	-	-	-	-	-	-	-	-
6000	-	-	-	0.30	0.77	1.14	-	-	-	-	-	-	-	-	-	-	-	-	-

## "BX" GRIPNOTCH® BELTS

**Table No.2 ("Drive Ratio Correction" Must Be Added to Ratings Listed Below)**

rpm of Sheaves	SHEAVE DATUM DIAMETERS (in.)																		
	3.00	3.20	3.40	3.60	3.80	4.00	4.20	4.40	4.60	4.80	5.00	5.20	5.40	5.60	5.80	6.00	6.20	6.40	6.60
1450	3.31	3.71	4.09	4.48	4.86	5.23	5.60	5.97	6.33	6.69	7.04	7.48	7.96	8.43	8.90	9.36	9.83	10.28	10.74
1750	3.72	4.17	4.62	5.07	5.50	5.93	6.36	6.78	7.19	7.60	8.08	8.64	9.19	9.73	10.27	10.81	11.34	11.86	12.39
2900	4.83	5.48	6.12	6.74	7.35	7.94	8.52	9.08	9.68	10.48	11.27	12.04	12.79	13.53	14.25	14.95	15.64	16.31	16.96
3500	5.16	5.89	6.59	7.27	7.93	8.57	9.19	9.79	10.57	11.43	12.28	13.09	13.89	14.65	15.39	16.10	16.79	17.44	18.07
400	**	**	**	**	**	**	**	**	**	**	**	**	**	**	**	**	**	**	**
600	**	**	**	**	**	**	**	**	**	**	**	**	**	**	4.33	4.51	4.73	4.95	5.16
800	**	**	**	**	**	**	**	**	3.87	4.09	4.32	4.54	4.77	4.99	5.21	5.48	5.76	6.04	6.32
1000	**	**	**	3.46	3.74	4.02	4.30	4.57	4.84	5.11	5.38	5.65	5.91	6.25	6.60	6.94	7.28	7.62	7.96
1200	2.93	3.27	3.60	3.93	4.26	4.58	4.90	5.22	5.53	5.85	6.15	6.46	6.85	7.25	7.66	8.05	8.45	8.85	9.24
1400	3.24	3.62	4.00	4.37	4.74	5.11	5.47	5.82	6.18	6.53	6.87	7.28	7.74	8.20	8.66	9.11	9.56	10.00	10.45
1600	3.52	3.95	4.37	4.78	5.19	5.59	5.99	6.38	6.77	7.16	7.56	8.07	8.59	9.10	9.60	10.10	10.60	11.09	11.58
1800	3.78	4.25	4.70	5.16	5.60	6.04	6.48	6.90	7.33	7.74	8.25	8.82	9.38	9.94	10.49	11.03	11.58	12.11	12.64
2000	4.02	4.52	5.02	5.50	5.99	6.46	6.93	7.39	7.84	8.28	8.90	9.52	10.12	10.72	11.32	11.90	12.48	13.06	13.62
2200	4.23	4.77	5.30	5.83	6.34	6.84	7.34	7.83	8.31	8.85	9.51	10.16	10.81	11.45	12.08	12.71	13.32	13.93	14.52
2400	4.43	5.00	5.57	6.12	6.66	7.20	7.72	8.23	8.74	9.37	10.07	10.76	11.45	12.12	12.79	13.44	14.08	14.72	15.34
2600	4.61	5.21	5.80	6.39	6.96	7.52	8.06	8.60	9.13	9.85	10.59	11.31	12.03	12.73	13.42	14.10	14.77	15.42	16.06
2800	4.76	5.40	6.02	6.63	7.22	7.81	8.38	8.93	9.50	10.28	11.05	11.81	12.55	13.28	13.99	14.69	15.37	16.04	16.69
3000	4.90	5.56	6.21	6.84	7.46	8.07	8.65	9.22	9.86	10.67	11.47	12.25	13.01	13.76	14.49	15.20	15.89	16.56	17.22
3200	5.02	5.71	6.38	7.03	7.67	8.29	8.89	9.48	10.17	11.01	11.83	12.63	13.41	14.17	14.91	15.62	16.32	16.99	17.64
3400	5.12	5.83	6.53	7.20	7.85	8.49	9.10	9.70	10.45	11.31	12.14	12.96	13.74	14.51	15.25	15.97	16.65	17.32	17.95
3600	5.20	5.94	6.65	7.34	8.01	8.65	9.27	9.87	10.67	11.55	12.40	13.22	14.01	14.78	15.51	16.22	16.89	17.54	18.15
3800	5.26	6.02	6.75	7.45	8.13	8.78	9.41	10.01	10.85	11.74	12.59	13.41	14.20	14.96	15.69	16.38	17.03	17.65	-
4000	5.31	6.08	6.82	7.54	8.22	8.88	9.51	10.10	10.98	11.87	12.73	13.54	14.32	15.07	15.77	16.44	17.06	-	-
4200	5.34	6.12	6.87	7.59	8.28	8.94	9.56	10.16	11.06	11.95	12.80	13.60	14.37	15.09	15.77	-	-	-	-
4400	5.34	6.14	6.90	7.63	8.32	8.97	9.59	10.21	11.09	11.97	12.80	13.59	14.33	15.02	-	-	-	-	-
4600	5.33	6.14	6.90	7.63	8.32	8.97	9.61	10.22	11.06	11.93	12.74	13.51	-	-	-	-	-	-	-
4800	5.30	6.11	6.88	7.60	8.29	8.96	9.59	10.18	10.98	11.83	12.61	-	-	-	-	-	-	-	-
5000	5.25	6.07	6.83	7.55	8.25	8.92	9.53	10.10	10.84	11.66	-	-	-	-	-	-	-	-	-
6000	4.71	5.54	6.30	7.00	7.61	8.16	-	-	-	-	-	-	-	-	-	-	-	-	-

\*\* Belt speeds are very low. Other types of drives should be considered; consult Application Engineering.

## B GRIPBELT® BELTS HORSEPOWER TABLES "B" SUPER GRIPBELT BELTS

Table No.1 ("Drive Ratio Correction" Must Be Added to Ratings Listed Below)

rpm of Smaller Sheave	SHEAVE DATUM DIAMETERS (in.)											DRIVE RATIO CORRECTION									
	6.80	7.00	7.10	7.40	7.90	8.00	8.40	8.60	8.90	9.00	9.40	1.02-1.03	1.04-1.06	1.07-1.08	1.09-1.12	1.13-1.16	1.17-1.22	1.23-1.32	1.33-1.50	1.51-& UP	
1450	9.43	9.85	10.06	10.68	11.69	11.89	12.68	13.06	13.63	13.82	14.57	0.08	0.16	0.24	0.32	0.40	0.48	0.56	0.64	0.72	
1750	10.66	11.13	11.37	12.06	13.17	13.39	14.25	14.66	15.28	15.48	16.27	0.10	0.19	0.29	0.39	0.49	0.58	0.68	0.78	0.88	
2900	13.12	13.62	13.86	14.54	15.55	15.73	16.40	-	-	-	-	0.16	0.32	0.48	0.64	0.81	0.97	1.13	1.29	1.45	
3500	12.68	13.06	-	-	-	-	-	-	-	-	-	0.19	0.39	0.58	0.78	0.97	1.17	1.36	1.56	1.75	
400	**	**	**	**	**	**	**	4.70	4.91	4.99	5.27	0.02	0.04	0.07	0.09	0.11	0.13	0.16	0.18	0.20	
600	4.77	4.97	5.08	5.39	5.90	6.01	6.41	6.62	6.92	7.02	7.42	0.03	0.07	0.10	0.13	0.17	0.20	0.23	0.27	0.30	
800	6.02	6.28	6.42	6.81	7.47	7.60	8.12	8.37	8.76	8.88	9.39	0.04	0.09	0.13	0.18	0.22	0.27	0.31	0.36	0.40	
1000	7.17	7.49	7.65	8.13	8.91	9.06	9.68	9.98	10.44	10.59	11.18	0.06	0.11	0.17	0.22	0.28	0.33	0.39	0.44	0.50	
1200	8.23	8.60	8.78	9.33	10.22	10.40	11.10	11.45	11.96	12.13	12.80	0.07	0.13	0.20	0.27	0.33	0.40	0.47	0.53	0.60	
1400	9.20	9.61	9.81	10.42	11.41	11.61	12.38	12.76	13.32	13.51	14.24	0.08	0.16	0.23	0.31	0.39	0.47	0.54	0.62	0.70	
1600	10.07	10.52	10.74	11.40	12.47	12.68	13.51	13.91	14.51	14.70	15.48	0.09	0.18	0.27	0.36	0.44	0.53	0.62	0.71	0.80	
1800	10.85	11.33	11.56	12.26	13.39	13.61	14.47	14.89	15.51	15.71	16.50	0.10	0.20	0.30	0.40	0.50	0.60	0.70	0.80	0.90	
2000	11.52	12.02	12.27	12.99	14.16	14.39	15.27	15.69	16.31	16.52	17.30	0.11	0.22	0.33	0.44	0.56	0.67	0.78	0.89	1.00	
2200	12.09	12.60	12.85	13.60	14.77	15.00	15.88	16.30	16.91	17.10	17.85	0.12	0.24	0.37	0.49	0.61	0.73	0.86	0.98	1.10	
2400	12.54	13.06	13.31	14.06	15.22	15.45	16.30	16.70	17.27	17.45	18.14	0.13	0.27	0.40	0.53	0.67	0.80	0.93	1.07	1.20	
2600	12.87	13.38	13.64	14.37	15.49	15.71	16.50	16.87	17.39	17.55	18.15	0.14	0.29	0.43	0.58	0.72	0.87	1.01	1.16	1.30	
2800	13.07	13.57	13.82	14.52	15.58	15.77	16.49	16.82	-	-	-	0.16	0.31	0.47	0.62	0.78	0.93	1.09	1.25	1.40	
3000	13.14	13.62	13.85	14.51	15.46	15.63	-	-	-	-	-	0.17	0.33	0.50	0.67	0.83	1.00	1.17	1.33	1.50	
3200	13.07	13.52	13.73	14.32	-	-	-	-	-	-	-	0.18	0.36	0.53	0.71	0.89	1.07	1.24	1.42	1.60	
3400	12.85	13.25	13.44	-	-	-	-	-	-	-	-	0.19	0.38	0.57	0.76	0.94	1.13	1.32	1.51	1.70	
3600	12.48	-	-	-	-	-	-	-	-	-	-	0.20	0.40	0.60	0.80	1.00	1.20	1.40	1.60	1.80	
3800	-	-	-	-	-	-	-	-	-	-	-	0.21	0.42	0.63	0.84	1.06	1.27	1.48	1.69	1.90	
4000	-	-	-	-	-	-	-	-	-	-	-	0.22	0.45	0.67	0.89	1.11	1.33	1.55	1.78	2.00	
4200	-	-	-	-	-	-	-	-	-	-	-	0.23	0.47	0.70	0.93	1.17	1.40	1.63	1.87	2.10	
4400	-	-	-	-	-	-	-	-	-	-	-	0.24	0.49	0.73	0.98	1.22	1.47	1.71	1.96	2.20	
4600	-	-	-	-	-	-	-	-	-	-	-	0.26	0.51	0.77	1.02	1.28	1.53	1.79	2.05	2.30	
4800	-	-	-	-	-	-	-	-	-	-	-	0.27	0.53	0.80	1.07	1.33	1.60	1.87	2.13	2.40	
5000	-	-	-	-	-	-	-	-	-	-	-	0.28	0.56	0.83	1.11	1.39	1.67	1.94	2.22	2.50	
6000	-	-	-	-	-	-	-	-	-	-	-	0.33	0.67	1.00	1.33	1.67	2.00	2.33	2.67	3.00	

## "BX" GRIPNOTCH® BELTS

Table No.2 ("Drive Ratio Correction" Must Be Added to Ratings Listed Below)

rpm of Smaller Sheave	SHEAVE DATUM DIAMETERS (in.)											DRIVE RATIO CORRECTION								
	6.80	7.00	7.10	7.40	7.90	8.00	8.40	8.60	8.90	9.00	9.40	1.03-1.07	1.08-1.13	1.14-1.21	1.22-1.30	1.31-1.44	1.45-1.64	1.65-2.01	2.02-3.00	3.01-& UP
1450	11.19	11.64	11.86	12.53	13.62	13.83	14.69	15.11	15.73	15.94	16.76	0.09	0.19	0.28	0.37	0.46	0.56	0.65	0.74	0.84
1750	12.90	13.41	13.67	14.42	15.65	15.89	16.84	17.31	18.00	18.23	19.13	0.11	0.22	0.34	0.45	0.56	0.67	0.79	0.90	1.01
2900	17.60	18.22	18.52	19.39	20.75	21.01	21.98	-	-	-	-	0.19	0.37	0.56	0.74	0.93	1.12	1.30	1.49	1.67
3500	18.66	19.22	-	-	-	-	-	-	-	-	-	0.22	0.45	0.67	0.90	1.12	1.35	1.57	1.79	2.02
400	**	**	**	**	**	**	**	5.11	5.33	5.40	5.70	0.03	0.05	0.08	0.10	0.13	0.15	0.18	0.21	0.23
600	5.38	5.59	5.70	6.02	6.55	6.66	7.08	7.29	7.60	7.71	8.12	0.04	0.08	0.12	0.15	0.19	0.23	0.27	0.31	0.35
800	6.88	7.15	7.29	7.70	8.38	8.52	9.06	9.33	9.73	9.86	10.39	0.05	0.10	0.15	0.21	0.26	0.31	0.36	0.41	0.46
1000	8.29	8.63	8.79	9.29	10.11	10.27	10.92	11.25	11.73	11.88	12.52	0.06	0.13	0.19	0.26	0.32	0.38	0.45	0.51	0.58
1200	9.63	10.02	10.21	10.79	11.73	11.92	12.67	13.04	13.59	13.77	14.50	0.08	0.15	0.23	0.31	0.38	0.46	0.54	0.62	0.69
1400	10.89	11.32	11.54	12.19	13.25	13.46	14.30	14.71	15.32	15.52	16.32	0.09	0.18	0.27	0.36	0.45	0.54	0.63	0.72	0.81
1600	12.07	12.55	12.79	13.50	14.66	14.89	15.80	16.25	16.91	17.13	17.99	0.10	0.21	0.31	0.41	0.51	0.62	0.72	0.82	0.92
1800	13.17	13.69	13.95	14.71	15.96	16.21	17.17	17.65	18.35	18.58	19.48	0.12	0.23	0.35	0.46	0.58	0.69	0.81	0.92	1.04
2000	14.18	14.74	15.01	15.82	17.14	17.40	18.41	18.90	19.63	19.86	20.79	0.13	0.26	0.38	0.51	0.64	0.77	0.90	1.03	1.15
2200	15.11	15.69	15.98	16.83	18.19	18.45	19.49	19.99	20.73	20.97	21.91	0.14	0.28	0.42	0.56	0.71	0.85	0.99	1.13	1.27
2400	15.95	16.55	16.84	17.71	19.10	19.37	20.42	20.92	21.65	21.89	22.81	0.15	0.31	0.46	0.62	0.77	0.92	1.08	1.23	1.38
2600	16.69	17.30	17.60	18.48	19.88	20.15	21.18	21.67	22.38	22.61	23.48	0.17	0.33	0.50	0.67	0.83	1.00	1.17	1.33	1.50
2800	17.32	17.94	18.24	19.12	20.50	20.76	21.76	22.23	-	-	-	0.18	0.36	0.54	0.72	0.90	1.08	1.26	1.44	1.62
3000	17.85	18.46	18.76	19.63	20.96	21.21	-	-	-	-	-	0.19	0.38	0.58	0.77	0.96	1.15	1.35	1.54	1.73
3200	18.26	18.86	19.16	19.99	-	-	-	-	-	-	-	0.21	0.41	0.62	0.82	1.03	1.23	1.44	1.64	1.85
3400	18.56	19.14	19.42	-	-	-	-	-	-	-	-	0.22	0.44	0.65	0.87	1.09	1.31	1.53	1.74	1.96
3600	18.73	-	-	-	-	-	-	-	-	-	-	0.23	0.46	0.69	0.92	1.15	1.38	1.61	1.85	2.08
3800	-	-	-	-	-	-	-	-	-	-	-	0.24	0.49	0.73	0.97	1.22	1.46	1.70	1.95	2.19
4000	-	-	-	-	-	-	-	-	-	-	-	0.26	0.51	0.77	1.03	1.28	1.54	1.79	2.05	2.31
4200	-	-	-	-	-	-	-	-	-	-	-	0.27	0.54	0.81	1.08	1.35	1.61	1.88	2.15	2.42
4400	-	-	-	-	-	-	-	-	-	-	-	0.28	0.56	0.85	1.13	1.41	1.69	1.97	2.26	2.54
4600	-	-	-	-	-	-	-	-	-	-	-	0.30	0.59	0.89	1.18	1.47	1.77	2.06	2.36	2.65
4800	-	-	-	-	-	-	-	-	-	-	-	0.31	0.62	0.92	1.23	1.54	1.85	2.15	2.46	2.77
5000	-	-	-	-	-	-	-	-	-	-	-	0.32	0.64	0.96	1.28	1.60	1.92	2.24	2.56	2.88
6000	-	-	-	-	-	-	-	-	-	-	-	0.39	0.77	1.15	1.54	1.92	2.31	2.69	3.08	3.46

\*\* Belt speeds are very low. Other types of drives should be considered; consult Application Engineering.

## C GRIPBELT® BELTS HORSEPOWER TABLES "C" SUPER GRIPBELT BELTS

**Table No.1 ("Drive Ratio Correction" Must Be Added to Ratings Listed Below)**

rpm of Smaller Sheave	SHEAVE DATUM DIAMETERS (in.)																		
	5.60	6.00	7.00	7.20	7.40	7.60	7.80	8.00	8.20	8.40	8.60	8.80	9.00	9.20	9.40	9.60	9.80	10.00	10.20
870	4.98	5.83	7.98	8.45	8.92	9.39	9.86	10.33	10.79	11.25	11.71	12.16	12.62	13.07	13.52	13.97	14.41	14.85	15.29
960	5.27	6.20	8.55	9.06	9.57	10.08	10.58	11.09	11.59	12.08	12.58	13.07	13.56	14.04	14.53	15.01	15.48	15.96	16.43
1160	5.85	6.93	9.69	10.29	10.88	11.46	12.05	12.62	13.20	13.77	14.33	14.89	15.45	16.00	16.55	17.10	17.64	18.17	18.70
1450	6.50	7.77	11.06	11.75	12.44	13.12	13.80	14.46	15.12	15.77	16.42	17.06	17.69	18.31	18.93	19.54	20.14	20.73	21.32
1750	6.94	8.38	12.09	12.86	13.62	14.37	15.11	15.84	16.56	17.27	17.96	18.65	19.32	19.98	20.62	21.26	21.88	22.49	23.09
300	**	**	**	**	**	**	**	**	**	**	**	**	**	**	**	**	**	**	**
400	**	**	**	**	**	**	**	**	**	**	6.34	6.57	6.81	7.05	7.28	7.52	7.75	7.99	8.22
500	**	**	5.34	5.60	5.86	6.15	6.44	6.73	7.02	7.31	7.60	7.89	8.18	8.46	8.75	9.04	9.32	9.60	9.89
600	**	4.57	6.11	6.41	6.75	7.09	7.44	7.78	8.12	8.46	8.80	9.13	9.47	9.81	10.14	10.47	10.80	11.13	11.46
700	4.36	5.07	6.82	7.20	7.60	7.99	8.38	8.77	9.16	9.54	9.93	10.31	10.69	11.07	11.45	11.83	12.21	12.58	12.95
800	4.73	5.53	7.51	7.95	8.39	8.83	9.27	9.70	10.14	10.57	11.00	11.42	11.85	12.27	12.69	13.11	13.53	13.95	14.36
900	5.08	5.96	8.17	8.66	9.14	9.63	10.11	10.58	11.06	11.53	12.00	12.47	12.94	13.40	13.86	14.32	14.78	15.23	15.68
1000	5.40	6.35	8.79	9.32	9.85	10.37	10.89	11.41	11.93	12.44	12.95	13.46	13.96	14.46	14.96	15.45	15.94	16.43	16.91
1100	5.69	6.72	9.37	9.94	10.50	11.07	11.63	12.19	12.74	13.29	13.83	14.37	14.91	15.45	15.98	16.50	17.03	17.54	18.06
1200	5.95	7.06	9.90	10.51	11.12	11.72	12.31	12.91	13.49	14.08	14.65	15.23	15.80	16.36	16.92	17.48	18.03	18.57	19.11
1300	6.19	7.36	10.40	11.04	11.68	12.32	12.95	13.57	14.19	14.80	15.41	16.01	16.61	17.20	17.79	18.37	18.94	19.51	20.07
1400	6.40	7.64	10.85	11.53	12.20	12.87	13.53	14.18	14.83	15.47	16.10	16.73	17.35	17.96	18.57	19.17	19.76	20.35	20.93
1500	6.59	7.89	11.26	11.97	12.67	13.36	14.05	14.73	15.40	16.07	16.72	17.37	18.01	18.64	19.27	19.88	20.49	21.09	21.68
1600	6.75	8.10	11.62	12.36	13.09	13.81	14.52	15.22	15.91	16.60	17.27	17.94	18.60	19.24	19.88	20.51	21.13	21.73	22.33
1700	6.88	8.29	11.94	12.71	13.46	14.20	14.93	15.65	16.36	17.06	17.75	18.43	19.10	19.75	20.40	21.03	21.66	22.27	22.87
1800	6.99	8.45	12.22	13.00	13.77	14.53	15.28	16.02	16.74	17.45	18.15	18.84	19.52	20.18	20.83	21.46	22.08	22.69	23.28
1900	7.07	8.58	12.44	13.25	14.03	14.81	15.57	16.32	17.05	17.77	18.48	19.17	19.84	20.51	21.15	21.78	22.40	23.00	23.58
2000	7.12	8.67	12.62	13.44	14.24	15.03	15.80	16.55	17.29	18.01	18.72	19.41	20.08	20.74	21.38	22.00	22.60	23.18	23.75
2200	7.15	8.76	12.82	13.66	14.48	15.27	16.05	16.80	17.54	18.25	18.95	19.62	20.27	20.90	21.50	22.08	22.64	23.18	23.69
2400	7.06	8.72	12.81	13.65	14.47	15.26	16.02	16.76	17.47	18.16	18.82	19.45	20.05	20.63	21.17	21.69	22.18	22.64	23.06
2600	6.85	8.54	12.58	13.40	14.20	14.96	15.69	16.39	17.06	17.70	18.30	18.87	19.40	19.89	20.36	-	-	-	-
3000	6.05	7.72	11.38	12.12	12.82	13.47	14.07	14.63	15.14	-	-	-	-	-	-	-	-	-	-
3400	4.70	6.25	9.24	9.69	-	-	-	-	-	-	-	-	-	-	-	-	-	-	-
3800	2.75	4.07	-	-	-	-	-	-	-	-	-	-	-	-	-	-	-	-	-
4100	0.86	1.92	-	-	-	-	-	-	-	-	-	-	-	-	-	-	-	-	-

## "CX" GRIPNOTCH® BELTS

**Table No.2 ("Drive Ratio Correction" Must Be Added to Ratings Listed Below)**

rpm of Smaller Sheave	SHEAVE DATUM DIAMETERS (in.)																		
	5.60	6.00	7.00	7.20	7.40	7.60	7.80	8.00	8.20	8.40	8.60	8.80	9.00	9.20	9.40	9.60	9.80	10.00	10.20
870	8.57	9.34	11.20	11.56	11.93	12.29	12.65	13.00	13.36	13.71	14.06	14.44	14.90	15.37	15.83	16.29	16.75	17.20	17.66
960	9.24	10.06	12.07	12.46	12.85	13.24	13.62	14.01	14.39	14.76	15.14	15.61	16.11	16.62	17.11	17.61	18.10	18.60	19.09
1160	10.62	11.57	13.88	14.33	14.78	15.22	15.66	16.10	16.53	16.96	17.47	18.06	18.64	19.21	19.78	20.35	20.92	21.48	22.04
1450	12.44	13.56	16.24	16.76	17.28	17.79	18.29	18.78	19.28	19.83	20.52	21.19	21.86	22.52	23.18	23.83	24.48	25.11	25.74
1750	14.10	15.36	18.35	18.93	19.49	20.05	20.60	21.13	21.66	22.39	23.14	23.88	24.61	25.34	26.05	26.75	27.44	28.12	28.79
300	**	**	**	**	**	**	**	**	**	**	**	**	**	**	**	**	**	**	**
400	**	**	**	**	**	**	**	**	**	**	7.58	7.76	7.95	8.14	8.33	8.51	8.74	8.97	9.21
500	**	**	7.24	7.47	7.71	7.94	8.17	8.40	8.63	8.86	9.09	9.31	9.54	9.76	10.00	10.29	10.58	10.86	11.15
600	**	6.99	8.38	8.65	8.92	9.19	9.46	9.72	9.99	10.26	10.52	10.78	11.04	11.32	11.66	12.00	12.34	12.68	13.01
700	7.25	7.89	9.46	9.77	10.08	10.38	10.68	10.99	11.29	11.58	11.88	12.18	12.49	12.87	13.26	13.65	14.03	14.41	14.80
800	8.04	8.75	10.50	10.84	11.18	11.52	11.86	12.19	12.52	12.85	13.18	13.51	13.93	14.36	14.79	15.22	15.65	16.08	16.51
900	8.80	9.58	11.49	11.87	12.24	12.61	12.98	13.34	13.70	14.06	14.42	14.83	15.31	15.79	16.26	16.74	17.21	17.67	18.14
1000	9.52	10.37	12.44	12.85	13.25	13.65	14.05	14.44	14.83	15.22	15.61	16.12	16.64	17.15	17.67	18.18	18.69	19.20	19.70
1100	10.22	11.13	13.35	13.79	14.22	14.65	15.07	15.49	15.91	16.32	16.79	17.35	17.90	18.46	19.01	19.56	20.10	20.65	21.18
1200	10.89	11.86	14.23	14.69	15.14	15.60	16.05	16.49	16.93	17.37	17.92	18.52	19.11	19.70	20.29	20.87	21.45	22.02	22.59
1300	11.53	12.56	15.06	15.55	16.03	16.51	16.98	17.45	17.91	18.37	19.00	19.63	20.26	20.88	21.50	22.11	22.72	23.32	23.91
1400	12.14	13.23	15.86	16.37	16.87	17.37	17.86	18.35	18.83	19.36	20.02	20.69	21.34	21.99	22.64	23.28	23.91	24.53	25.16
1500	12.74	13.88	16.62	17.15	17.67	18.19	18.70	19.21	19.71	20.30	20.99	21.68	22.36	23.04	23.71	24.37	25.02	25.67	26.31
1600	13.30	14.49	17.34	17.89	18.43	18.97	19.49	20.01	20.53	21.18	21.90	22.61	23.31	24.01	24.70	25.38	26.05	26.72	27.37
1700	13.84	15.08	18.03	18.59	19.15	19.70	20.24	20.77	21.30	22.00	22.74	23.47	24.20	24.91	25.62	26.32	27.00	27.68	28.34
1800	14.36	15.64	18.67	19.25	19.82	20.39	20.94	21.48	22.02	22.76	23.52	24.27	25.01	25.74	26.46	27.17	27.86	28.55	29.22
1900	14.85	16.17	19.28	19.87	20.46	21.03	21.59	22.14	22.68	23.46	24.24	25.00	25.75	26.49	27.22	27.93	28.63	29.32	29.99
2000	15.32	16.67	19.85	20.45	21.04	21.62	22.19	22.75	23.30	24.10	24.88	25.66	26.41	27.16	27.89	28.60	29.30	29.99	30.66
2200	16.18	17.59	20.87	21.49	22.10	22.71	23.30	23.88	24.44	25.17	25.97	26.74	27.50	28.24	28.97	29.67	30.35	31.02	31.66
2400	16.94	18.40	21.77	22.41	23.04	23.64	24.23	24.80	25.36	26.15	26.95	27.75	28.56	29.37	30.14	30.88	31.60	32.20	-
2600	17.60	19.08	22.55	23.18	23.80	24.39	24.96	25.51	26.04	26.55	27.22	27.95	28.65	29.32	29.97	-	-	-	-
3000	18.65	20.20	23.59	24.18	24.74	25.27	25.77	26.23	26.67	-	-	-	-	-	-	-	-	-	-
3400	19.34	20.84	23.91	24.40	-	-	-	-	-	-	-	-	-	-	-	-	-	-	-
3800	19.59	20.95	-	-	-	-	-	-	-	-	-	-	-	-	-	-	-	-	-
4100	19.45	20.65	-	-	-	-	-	-	-	-	-	-	-	-	-	-	-	-	-

\*\* Belt Speeds are very low, other types of drives should be considered; consult Application Engineering.

## C GRIPBELT® BELTS HORSEPOWER TABLES "C" SUPER GRIPBELT BELTS

**Table No.1 ("Drive Ratio Correction" Must Be Added to Ratings Listed Below)**

rpm of Smaller Sheave	SHEAVE DATUM DIAMETERS (in.)											DRIVE RATIO CORRECTION									
	10.60	11.00	11.40	12.00	13.00	14.00	15.00	16.00	18.00	20.00	22.00	1.02-1.03	1.04-1.06	1.07-1.08	1.09-1.12	1.13-1.16	1.17-1.22	1.23-1.32	1.33-1.50	1.51-& UP	
870	16.17	17.03	17.88	19.15	21.21	23.20	25.14	27.00	30.53	33.76	36.69	0.11	0.23	0.34	0.45	0.57	0.68	0.79	0.91	1.02	
960	17.37	18.29	19.20	20.54	22.72	24.82	26.84	28.78	32.38	35.61	38.42	0.13	0.25	0.38	0.50	0.63	0.75	0.87	1.00	1.13	
1160	19.75	20.78	21.79	23.27	25.64	27.88	29.99	31.96	35.46	38.33	-	0.15	0.30	0.45	0.60	0.76	0.91	1.06	1.21	1.36	
1450	22.47	23.58	24.66	26.22	28.65	30.84	32.79	34.48	-	-	-	0.19	0.38	0.57	0.76	0.94	1.13	1.32	1.51	1.70	
1750	24.24	25.35	26.39	27.86	30.00	31.76	-	-	-	-	-	0.23	0.46	0.68	0.91	1.14	1.37	1.59	1.82	2.05	
300	**	**	**	8.06	8.95	9.82	10.69	11.55	13.25	14.92	16.56	0.04	0.08	0.12	0.16	0.20	0.23	0.27	0.31	0.35	
400	8.68	9.15	9.61	10.29	11.43	12.55	13.65	14.75	16.91	19.01	21.07	0.05	0.10	0.16	0.21	0.26	0.31	0.36	0.42	0.47	
500	10.45	11.01	11.57	12.39	13.76	15.11	16.44	17.75	20.31	22.79	25.20	0.07	0.13	0.20	0.26	0.33	0.39	0.46	0.52	0.59	
600	12.12	12.77	13.42	14.38	15.96	17.51	19.04	20.54	23.45	26.25	28.93	0.08	0.16	0.23	0.31	0.39	0.47	0.55	0.63	0.70	
700	13.70	14.43	15.16	16.24	18.02	19.76	21.46	23.12	26.32	29.36	32.22	0.09	0.18	0.27	0.36	0.46	0.55	0.64	0.73	0.82	
800	15.18	15.99	16.80	17.99	19.94	21.84	23.69	25.48	28.90	32.09	35.03	0.10	0.21	0.31	0.42	0.52	0.63	0.73	0.83	0.94	
900	16.57	17.46	18.33	19.62	21.73	23.76	25.72	27.62	31.18	34.42	37.32	0.12	0.23	0.35	0.47	0.59	0.70	0.82	0.94	1.05	
1000	17.87	18.82	19.75	21.13	23.36	25.50	27.55	29.50	33.11	36.31	39.04	0.13	0.26	0.39	0.52	0.65	0.78	0.91	1.04	1.17	
1100	19.08	20.08	21.06	22.51	24.83	27.05	29.15	31.12	34.70	37.72	40.15	0.14	0.29	0.43	0.57	0.72	0.86	1.00	1.15	1.29	
1200	20.18	21.22	22.25	23.75	26.15	28.40	30.51	32.47	35.89	38.63	-	0.16	0.31	0.47	0.62	0.78	0.94	1.09	1.25	1.41	
1300	21.18	22.26	23.31	24.85	27.28	29.54	31.62	33.51	36.68	-	-	0.17	0.34	0.51	0.68	0.85	1.02	1.18	1.35	1.52	
1400	22.06	23.17	24.25	25.80	28.24	30.46	32.47	34.24	-	-	-	0.18	0.37	0.55	0.73	0.91	1.09	1.28	1.46	1.64	
1500	22.84	23.96	25.04	26.60	29.00	31.15	33.03	34.63	-	-	-	0.20	0.39	0.59	0.78	0.98	1.17	1.37	1.56	1.76	
1600	23.49	24.62	25.70	27.23	29.56	31.59	33.30	-	-	-	-	0.21	0.42	0.63	0.83	1.04	1.25	1.46	1.67	1.88	
1700	24.03	25.14	26.20	27.69	29.91	31.77	-	-	-	-	-	0.22	0.44	0.67	0.89	1.11	1.33	1.55	1.77	1.99	
1800	24.43	25.52	26.55	27.98	30.04	-	-	-	-	-	-	0.23	0.47	0.70	0.94	1.17	1.41	1.64	1.88	2.11	
1900	24.70	25.75	26.73	28.07	29.93	-	-	-	-	-	-	0.25	0.50	0.74	0.99	1.24	1.49	1.73	1.98	2.23	
2000	24.83	25.82	26.74	27.97	-	-	-	-	-	-	-	0.26	0.52	0.78	1.04	1.30	1.56	1.82	2.08	2.34	
2000	24.64	25.49	-	-	-	-	-	-	-	-	-	0.29	0.57	0.86	1.15	1.43	1.72	2.00	2.29	2.58	
2400	-	-	-	-	-	-	-	-	-	-	-	0.31	0.63	0.94	1.25	1.56	1.88	2.19	2.50	2.81	
2600	-	-	-	-	-	-	-	-	-	-	-	0.34	0.68	1.02	1.35	1.69	2.03	2.37	2.71	3.05	
3000	-	-	-	-	-	-	-	-	-	-	-	0.39	0.78	1.17	1.56	1.95	2.35	2.73	3.13	3.52	
3400	-	-	-	-	-	-	-	-	-	-	-	0.44	0.89	1.33	1.77	2.21	2.66	3.10	3.54	3.98	
3800	-	-	-	-	-	-	-	-	-	-	-	0.50	0.99	1.49	1.98	2.48	2.97	3.46	3.96	4.45	
4100	-	-	-	-	-	-	-	-	-	-	-	0.53	1.07	1.60	2.14	2.67	3.21	3.74	4.27	4.80	

## "CX" GRIPNOTCH® BELTS

**Table No.2 ("Drive Ratio Correction" Must Be Added to Ratings Listed Below)**

rpm of Smaller Sheave	SHEAVE DATUM DIAMETERS (in.)											DRIVE RATIO CORRECTION								
	10.60	11.00	11.40	12.00	13.00	14.00	15.00	16.00	18.00	20.00	22.00	1.03-1.07	1.08-1.13	1.14-1.21	1.22-1.30	1.31-1.44	1.45-1.64	1.65-2.01	2.02-3.00	3.01-& UP
870	18.56	19.45	20.34	21.65	23.80	25.90	27.94	29.92	33.72	37.28	40.57	0.11	0.21	0.31	0.42	0.52	0.63	0.73	0.84	0.94
960	20.06	21.02	21.97	23.37	25.67	27.89	30.05	32.14	36.08	39.72	43.01	0.12	0.23	0.35	0.46	0.58	0.69	0.81	0.93	1.04
1160	23.14	24.23	25.30	26.88	29.43	31.87	34.20	36.41	40.47	44.01	-	0.14	0.28	0.42	0.56	0.70	0.84	0.98	1.12	1.26
1450	26.99	28.20	29.39	31.12	33.85	36.39	38.74	40.87	-	-	-	0.18	0.35	0.52	0.70	0.87	1.05	1.22	1.40	1.57
1750	30.10	31.37	32.58	34.32	36.98	39.31	-	-	-	-	-	0.21	0.42	0.63	0.84	1.06	1.27	1.48	1.69	1.90
300	**	**	**	8.80	9.70	10.58	11.46	12.34	14.06	15.76	17.43	0.04	0.07	0.11	0.14	0.18	0.22	0.25	0.29	0.33
400	9.68	10.15	10.62	11.31	12.46	13.60	14.73	15.85	18.05	20.21	22.33	0.05	0.10	0.14	0.19	0.24	0.29	0.34	0.39	0.43
500	11.72	12.29	12.86	13.70	15.10	16.48	17.84	19.18	21.82	24.39	26.90	0.06	0.12	0.18	0.24	0.30	0.36	0.42	0.48	0.54
600	13.68	14.35	15.01	15.99	17.61	19.21	20.78	22.33	25.36	28.29	31.11	0.07	0.14	0.22	0.29	0.36	0.43	0.51	0.58	0.65
700	15.56	16.31	17.06	18.17	20.01	21.81	23.57	25.31	28.67	31.89	34.96	0.08	0.17	0.25	0.34	0.42	0.51	0.59	0.68	0.76
800	17.35	18.19	19.02	20.26	22.28	24.26	26.20	28.09	31.73	35.18	38.41	0.10	0.19	0.29	0.39	0.48	0.58	0.68	0.77	0.87
900	19.07	19.98	20.89	22.24	24.43	26.58	28.66	30.68	34.54	38.12	41.43	0.11	0.22	0.33	0.43	0.54	0.65	0.76	0.87	0.98
1000	20.70	21.69	22.67	24.11	26.46	28.74	30.94	33.06	37.06	40.71	43.97	0.12	0.24	0.36	0.48	0.60	0.72	0.84	0.96	1.09
1100	22.25	23.30	24.34	25.87	28.36	30.74	33.03	35.23	39.29	42.90	46.02	0.13	0.27	0.40	0.53	0.66	0.80	0.93	1.06	1.19
1200	23.72	24.83	25.92	27.52	30.11	32.58	34.93	37.15	41.20	44.67	-	0.14	0.29	0.43	0.58	0.72	0.87	1.01	1.16	1.30
1300	25.09	26.25	27.39	29.06	31.72	34.25	36.62	38.84	42.77	-	-	0.16	0.31	0.47	0.63	0.78	0.94	1.10	1.25	1.41
1400	26.38	27.58	28.75	30.46	33.18	35.73	38.09	40.26	-	-	-	0.17	0.34	0.51	0.67	0.84	1.01	1.18	1.35	1.52
1500	27.57	28.80	30.00	31.74	34.48	37.01	39.32	41.40	-	-	-	0.18	0.36	0.54	0.72	0.90	1.08	1.27	1.45	1.63
1600	28.66	29.91	31.13	32.88	35.61	38.10	40.31	-	-	-	-	0.19	0.39	0.58	0.77	0.96	1.16	1.35	1.54	1.74
1700	29.65	30.91	32.13	33.88	36.57	38.96	-	-	-	-	-	0.21	0.41	0.62	0.82	1.03	1.23	1.43	1.64	1.85
1800	30.53	31.79	33.00	34.73	37.34	-	-	-	-	-	-	0.22	0.43	0.65	0.87	1.09	1.30	1.52	1.74	1.95
1900	31.30	32.55	33.74	35.43	37.92	-	-	-	-	-	-	0.23	0.46	0.69	0.92	1.15	1.37	1.60	1.83	2.06
2000	31.95	33.18	34.34	35.96	-	-	-	-	-	-	-	0.24	0.48	0.72	0.96	1.21	1.45	1.69	1.93	2.17
2200	32.89	34.03	-	-	-	-	-	-	-	-	-	0.27	0.53	0.80	1.06	1.33	1.59	1.86	2.12	2.39
2400	-	-	-	-	-	-	-	-	-	-	-	0.29	0.58	0.87	1.16	1.45	1.74	2.03	2.32	2.60
2600	-	-	-	-	-	-	-	-	-	-	-	0.31	0.63	0.94	1.25	1.57	1.88	2.19	2.51	2.82
3000	-	-	-	-	-	-	-	-	-	-	-	0.36	0.72	1.09	1.45	1.81	2.17	2.53	2.89	3.26
3400	-	-	-	-	-	-	-	-	-	-	-	0.41	0.82	1.23	1.64	2.05	2.46	2.87	3.28	3.69
3800	-	-	-	-	-	-	-	-	-	-	-	0.46	0.92	1.38	1.83	2.29	2.75	3.21	3.67	4.12
4100	-	-	-	-	-	-	-	-	-	-	-	0.50	0.99	1.48	1.98	2.47	2.97	3.46	3.95	4.45

\*\* Belt speeds are very low. Other types of drives should be considered; consult Application Engineering.

## D GRIPBELT® BELTS HORSEPOWER TABLES "D" SUPER GRIPBELT BELTS AND GRIPNOTCH® BELTS

**Table No.1 ("Drive Ratio Correction" Must Be Added to Ratings Listed Below)**

rpm of Smaller Sheave	SHEAVE DATUM DIAMETERS (in.)														
	12.0	13.0	13.4	13.8	14.2	14.6	15.0	15.4	16.0	17.0	18.0"	19.0	20.0	21.0	22.0
580	17.5	20.4	21.5	22.7	23.8	24.9	26.1	27.2	28.8	31.5	34.2	36.8	39.4	41.9	44.3
700	19.7	23.0	24.3	25.7	27.0	28.3	29.5	30.8	32.7	35.7	38.7	41.6	44.5	47.2	49.9
870	22.2	26.1	27.7	29.2	30.7	32.1	33.6	35.0	37.1	40.5	43.8	46.9	49.9	52.8	55.5
1160	25.1	29.7	31.4	33.1	34.8	36.4	38.0	39.5	41.7	45.2	48.5	51.4	54.0	56.3	-
200	**	**	**	**	**	**	**	**	**	**	15.1	16.3	17.4	18.5	19.6
400	13.5	15.7	16.6	17.4	18.3	19.1	19.9	20.8	22.0	24.1	26.1	28.1	30.1	32.0	34.0
600	17.8	20.8	22.0	23.2	24.4	25.5	26.7	27.8	29.5	32.3	35.0	37.7	40.3	42.9	45.3
800	21.3	24.9	26.4	27.8	29.2	30.7	32.0	33.4	35.4	38.7	41.9	45.0	47.9	50.8	53.5
1000	23.8	28.0	29.7	31.3	32.9	34.4	36.0	37.5	39.7	43.2	46.6	49.7	52.7	55.4	57.9
1200	25.4	30.0	31.7	33.4	35.1	36.7	38.3	39.8	42.1	45.5	48.7	51.5	54.0	-	-
1400	26.0	30.7	32.5	34.2	35.8	37.4	38.9	40.3	42.3	45.4	-	-	-	-	-
1600	25.5	30.1	31.8	33.3	34.8	36.2	37.5	38.7	-	-	-	-	-	-	-
1800	23.9	28.0	29.5	-	-	-	-	-	-	-	-	-	-	-	-

\*\* Belt Speeds are very low, other types of drives should be considered; consult Application Engineering.

## "D" SUPER GRIPBELT BELTS® AND GRIPNOTCH® BELTS

("Drive Ratio Correction" Must Be Added to Ratings Listed Below)

rpm of Smaller Sheave	SHEAVE DATUM DIAMETERS (in.)						DRIVE RATIO CORRECTION								
	23.0	24.0	25.0	26.0	27.0	28.0	1.02 - 1.05	1.06 - 1.11	1.12 - 1.18	1.19 - 1.26	1.27 - 1.38	1.39 - 1.57	1.58 - 1.94	1.95 - 2.99	3.00 & UP
580	46.7	49.1	51.4	53.6	55.8	57.9	.3	.7	1.1	1.4	1.7	2.0	2.2	2.4	2.4
700	52.4	54.9	57.3	59.6	61.8	63.9	.4	.9	1.3	1.7	2.1	2.4	2.7	2.9	2.9
870	58.1	60.4	62.7	64.7	66.6	68.3	.5	1.1	1.6	2.1	2.6	3.0	3.3	3.6	3.6
1160	-	-	-	-	-	-	.7	1.4	2.2	2.8	3.4	4.0	4.4	4.7	4.8
200	20.7	21.8	22.9	24.0	25.0	26.1	.1	.2	.4	.5	.6	.7	.8	.8	.8
400	35.9	37.8	39.6	41.5	43.3	45.1	.2	.5	.8	1.0	1.2	1.4	1.5	1.6	1.7
600	47.8	50.2	52.5	54.7	56.9	59.0	.3	.7	1.1	1.5	1.8	2.1	2.3	2.5	2.5
800	56.1	58.6	60.9	63.1	65.2	67.1	.4	1.0	1.5	2.0	2.4	2.7	3.1	3.3	3.3
1000	60.2	62.3	-	-	-	-	.6	1.2	1.9	2.4	3.0	3.4	3.8	4.1	4.1
1200	-	-	-	-	-	-	.7	1.5	2.3	2.9	3.5	4.1	4.6	4.9	5.0
1400	-	-	-	-	-	-	.8	1.7	2.6	3.4	4.1	4.8	5.3	5.7	5.8
1600	-	-	-	-	-	-	.9	2.0	3.0	3.9	4.7	5.5	6.1	6.5	6.6
1800	-	-	-	-	-	-	1.0	2.2	3.4	4.4	5.3	6.2	6.9	7.4	7.4

## 3V GRIPBELT® BELTS HORSEPOWER TABLES "3VX" GRIPNOTCH® BELTS

**Table No.1 ("Drive Ratio Correction" Must Be Added to Ratings Listed Below)**

rpm of Smaller Sheaves	SHEAVE PITCH DIAMETERS (in.)														
	2.15	2.30	2.45	2.60	2.75	2.95	3.10	3.30	3.60	4.07	4.45	4.7	4.95	5.25	5.55
1160	**	**	**	**	**	**	2.10	2.34	2.68	3.22	3.65	3.93	4.21	4.55	4.88
1450	**	**	1.62	1.83	2.05	2.34	2.55	2.84	3.26	3.92	4.45	4.79	5.14	5.54	5.95
1750	1.37	1.63	1.89	2.15	2.41	2.75	3.01	3.34	3.85	4.63	5.25	5.65	6.05	6.53	7.01
2900	2.03	2.44	2.85	3.26	3.66	4.20	4.59	5.12	5.90	7.09	8.04	8.64	9.24	9.95	10.64
3500	2.33	2.81	3.30	3.78	4.25	4.88	5.34	5.96	6.86	8.24	9.31	10.01	10.68	11.47	12.24
600	**	**	**	**	**	**	**	**	**	**	**	**	**	**	**
800	**	**	**	**	**	**	**	**	**	**	2.62	2.82	3.02	3.26	3.49
1000	**	**	**	**	**	**	**	**	2.35	2.82	3.20	3.44	3.69	3.98	4.27
1200	**	**	**	**	**	1.99	2.17	2.41	2.76	3.32	3.76	4.05	4.34	4.69	5.03
1400	**	**	**	1.78	1.99	2.27	2.48	2.75	3.17	3.80	4.31	4.65	4.98	5.37	5.77
1600	1.27	1.51	1.75	1.99	2.23	2.55	2.78	3.09	3.56	4.28	4.85	5.23	5.60	6.04	6.48
1800	1.40	1.67	1.94	2.20	2.47	2.82	3.08	3.43	3.94	4.74	5.38	5.79	6.20	6.69	7.18
2000	1.52	1.82	2.11	2.40	2.70	3.08	3.37	3.75	4.32	5.19	5.89	6.34	6.79	7.33	7.86
2200	1.64	1.96	2.28	2.60	2.92	3.34	3.65	4.07	4.68	5.63	6.39	6.88	7.37	7.94	8.51
2400	1.75	2.10	2.45	2.79	3.14	3.59	3.93	4.38	5.04	6.06	6.88	7.40	7.92	8.54	9.15
2600	1.86	2.24	2.61	2.98	3.35	3.84	4.20	4.68	5.39	6.48	7.35	7.91	8.46	9.12	9.76
2800	1.97	2.37	2.77	3.17	3.56	4.08	4.46	4.97	5.73	6.89	7.81	8.40	8.99	9.68	10.36
3000	2.08	2.50	2.93	3.35	3.76	4.31	4.72	5.26	6.06	7.29	8.26	8.88	9.50	10.22	10.93
3200	2.18	2.63	3.08	3.52	3.96	4.54	4.98	5.55	6.39	7.68	8.69	9.34	9.98	10.74	11.47
3400	2.28	2.75	3.23	3.69	4.16	4.77	5.22	5.82	6.70	8.05	9.11	9.79	10.45	11.23	11.99
3600	2.37	2.87	3.37	3.86	4.35	4.99	5.46	6.09	7.01	8.42	9.51	10.22	10.91	11.71	12.49
3800	2.47	2.99	3.51	4.02	4.53	5.20	5.70	6.35	7.31	8.77	9.90	10.63	11.34	12.16	12.96
4000	2.56	3.10	3.64	4.18	4.71	5.41	5.92	6.60	7.60	9.11	10.28	11.02	11.75	12.59	13.40
4400	2.73	3.32	3.90	4.48	5.05	5.80	6.36	7.09	8.15	9.75	10.98	11.76	12.51	13.37	14.19
4800	2.89	3.52	4.15	4.77	5.38	6.18	6.77	7.54	8.66	10.34	11.61	12.41	13.17	-	-
5200	3.03	3.71	4.38	5.03	5.68	6.53	7.15	7.96	9.13	10.87	12.17	12.98	-	-	-
5600	3.17	3.88	4.59	5.28	5.96	6.85	7.50	8.34	9.56	11.34	-	-	-	-	-
6000	3.29	4.04	4.78	5.51	6.22	7.14	7.82	8.69	9.94	11.74	-	-	-	-	-
7000	3.54	4.38	5.20	5.99	6.76	7.76	8.48	9.39	-	-	-	-	-	-	-
7500	3.63	4.51	5.36	6.18	6.98	7.99	8.72	9.65	-	-	-	-	-	-	-
8000	3.70	4.61	5.49	6.33	7.15	8.18	8.91	-	-	-	-	-	-	-	-

## "3VX" GRIPNOTCH BELTS ("Drive Ratio Correction" Must Be Added to Ratings Listed Below)

rpm of Smaller Sheave	SHEAVE PITCH DIAMETERS (in.)					DRIVE RATIO CORRECTION									
	5.95	6.45	6.85	7.95	10.55	1.02-1.03	1.04-1.06	1.07-1.09	1.10-1.13	1.14-1.18	1.19-1.25	1.26-1.35	1.36-1.57	1.58-& UP	
1160	5.32	5.86	6.30	7.47	10.13	0.02	0.04	0.05	0.07	0.09	0.11	0.13	0.15	0.16	
1450	6.48	7.14	7.66	9.07	12.23	0.02	0.05	0.07	0.09	0.11	0.14	0.16	0.18	0.21	
1750	7.63	8.40	9.01	10.64	14.22	0.03	0.06	0.08	0.11	0.14	0.17	0.19	0.22	0.25	
2900	11.55	12.64	13.48	15.64	-	0.05	0.09	0.14	0.18	0.23	0.27	0.32	0.37	0.41	
3500	13.23	14.41	15.30	-	-	0.05	0.11	0.16	0.22	0.28	0.33	0.39	0.44	0.50	
600	2.93	3.23	3.47	4.13	5.63	0.01	0.02	0.03	0.04	0.05	0.06	0.07	0.08	0.08	
800	3.81	4.20	4.51	5.36	7.30	0.01	0.03	0.04	0.05	0.06	0.08	0.09	0.10	0.11	
1000	4.66	5.14	5.52	6.55	8.90	0.02	0.03	0.05	0.06	0.08	0.09	0.11	0.13	0.14	
1200	5.48	6.04	6.49	7.69	10.43	0.02	0.04	0.06	0.08	0.09	0.11	0.13	0.15	0.17	
1400	6.28	6.93	7.43	8.80	11.88	0.02	0.04	0.07	0.09	0.11	0.13	0.15	0.18	0.20	
1600	7.06	7.78	8.35	9.87	13.25	0.03	0.05	0.08	0.10	0.13	0.15	0.18	0.20	0.23	
1800	7.82	8.61	9.23	10.89	14.53	0.03	0.06	0.08	0.11	0.14	0.17	0.20	0.23	0.25	
2000	8.55	9.41	10.08	11.87	15.72	0.03	0.06	0.09	0.13	0.16	0.19	0.22	0.25	0.28	
2200	9.26	10.18	10.90	12.80	16.80	0.03	0.07	0.10	0.14	0.17	0.21	0.24	0.28	0.31	
2400	9.95	10.92	11.68	13.68	-	0.04	0.08	0.11	0.15	0.19	0.23	0.26	0.30	0.34	
2600	10.61	11.63	12.43	14.50	-	0.04	0.08	0.12	0.16	0.20	0.25	0.29	0.33	0.37	
2800	11.24	12.31	13.14	15.27	-	0.04	0.09	0.13	0.18	0.22	0.26	0.31	0.35	0.40	
3000	11.85	12.95	13.81	15.98	-	0.05	0.09	0.14	0.19	0.24	0.28	0.33	0.38	0.42	
3200	12.42	13.56	14.44	-	-	0.05	0.10	0.15	0.20	0.25	0.30	0.35	0.40	0.45	
3400	12.97	14.14	15.02	-	-	0.05	0.11	0.16	0.21	0.27	0.32	0.37	0.43	0.48	
3600	13.49	14.67	15.56	-	-	0.06	0.11	0.17	0.23	0.28	0.34	0.40	0.45	0.51	
3800	13.97	15.16	-	-	-	0.06	0.12	0.18	0.24	0.30	0.36	0.42	0.48	0.54	
4000	14.42	-	-	-	-	0.06	0.13	0.19	0.25	0.31	0.38	0.44	0.50	0.57	
4400	-	-	-	-	-	0.07	0.14	0.21	0.28	0.35	0.42	0.48	0.55	0.62	
4800	-	-	-	-	-	0.08	0.15	0.23	0.30	0.38	0.45	0.53	0.60	0.68	
5200	-	-	-	-	-	0.08	0.16	0.24	0.33	0.41	0.49	0.57	0.65	0.74	
5600	-	-	-	-	-	0.09	0.18	0.26	0.35	0.44	0.53	0.62	0.71	0.79	
6000	-	-	-	-	-	0.09	0.19	0.28	0.38	0.47	0.57	0.66	0.76	0.85	
7000	-	-	-	-	-	0.11	0.22	0.33	0.44	0.55	0.66	0.77	0.88	0.99	
7500	-	-	-	-	-	0.12	0.24	0.35	0.47	0.59	0.71	0.83	0.94	1.06	
8000	-	-	-	-	-	0.13	0.25	0.38	0.50	0.63	0.76	0.88	1.01	1.13	

\*\* Belt Speeds are very low, other types of drives should be considered; consult Application Engineering.



5V

# 5V GRIPBELT® BELTS HORSEPOWER TABLES

## "5V" SUPER GRIPBELT BELTS

**Table No.1 ("Drive Ratio Correction" Must Be Added to Ratings Listed Below)**

rpm of Smaller Sheave	SHEAVE PITCH DIAMETERS (in.)																			
	7.00	7.10	7.40	7.50	7.90	8.10	8.40	8.70	8.90	9.10	9.15	9.50	9.65	10.20	10.80	11.10	11.20	11.70	12.40	12.50
1160	11.42	11.71	12.60	12.90	14.07	14.65	15.52	16.38	16.95	17.52	17.66	18.65	19.07	20.59	22.22	23.03	23.29	24.61	26.43	26.68
1450	13.59	13.95	15.01	15.36	16.76	17.45	18.47	19.49	20.16	20.82	20.99	22.14	22.62	24.38	26.26	27.17	27.48	28.97	31.00	31.28
1750	15.60	16.01	17.22	17.62	19.21	19.99	21.15	22.29	23.04	23.78	23.96	25.24	25.77	27.70	29.73	30.71	31.03	32.60	34.70	34.99
2900	20.65	21.16	22.66	23.14	25.00	25.89	27.16	-	-	-	-	-	-	-	-	-	-	-	-	-
3500	21.29	-	-	-	-	-	-	-	-	-	-	-	-	-	-	-	-	-	-	-
300	**	**	**	**	**	**	**	**	**	7.68	8.27	8.36	8.86	9.37	9.54	10.37	10.87	11.20	11.37	13.33
400	**	**	**	**	**	**	**	6.58	6.81	7.04	7.09	7.49	7.66	8.27	8.94	9.28	9.39	9.94	10.71	10.82
500	5.63	5.77	6.19	6.33	6.90	7.18	7.60	8.01	8.29	8.57	8.64	9.12	9.33	10.08	10.90	11.31	11.44	12.12	13.06	13.19
600	6.58	6.75	7.25	7.42	8.08	8.41	8.91	9.40	9.73	10.05	10.13	10.70	10.95	11.83	12.79	13.27	13.43	14.22	15.32	15.48
700	7.51	7.70	8.28	8.47	9.23	9.61	10.18	10.74	11.12	11.49	11.58	12.23	12.51	13.53	14.62	15.17	15.35	16.25	17.50	17.68
800	8.41	8.62	9.27	9.49	10.34	10.77	11.41	12.04	12.46	12.88	12.99	13.72	14.03	15.16	16.39	17.00	17.20	18.21	19.60	19.80
900	9.28	9.52	10.24	10.47	11.42	11.89	12.60	13.30	13.76	14.23	14.34	15.15	15.49	16.74	18.10	18.76	18.99	20.09	21.62	21.83
1000	10.12	10.38	11.17	11.43	12.47	12.98	13.75	14.52	15.03	15.53	15.66	16.53	16.91	18.27	19.74	20.46	20.70	21.89	23.54	23.77
1100	10.94	11.22	12.07	12.36	13.48	14.04	14.87	15.70	16.24	16.79	16.92	17.87	18.27	19.74	21.31	22.09	22.34	23.62	25.37	25.62
1200	11.73	12.04	12.95	13.25	14.46	15.06	15.95	16.83	17.42	18.00	18.15	19.16	19.59	21.14	22.81	23.64	23.91	25.26	27.11	27.37
1300	12.49	12.82	13.80	14.12	15.40	16.04	16.99	17.93	18.55	19.17	19.32	20.39	20.84	22.49	24.25	25.11	25.40	26.81	28.75	29.02
1400	3.23	3.58	4.61	4.96	6.31	6.99	7.99	8.98	9.63	10.28	10.44	21.57	22.04	23.77	25.61	26.51	26.81	28.27	30.27	30.55
1500	13.94	14.31	15.40	15.76	17.19	17.90	18.95	19.98	20.67	21.35	21.52	22.69	23.19	24.98	26.89	27.82	28.13	29.64	31.69	31.97
1600	14.63	15.01	16.15	16.53	18.03	18.76	19.86	20.94	21.66	22.36	22.54	23.75	24.27	26.13	28.09	29.04	29.36	30.91	32.99	33.28
1700	15.28	15.68	16.87	17.27	18.83	19.59	20.73	21.85	22.59	23.32	23.50	24.76	25.29	27.20	29.20	30.18	30.50	32.07	34.16	34.45
1800	15.91	16.33	17.56	17.97	19.59	20.38	21.56	22.71	23.47	24.23	24.41	25.70	26.24	28.19	30.23	31.22	31.54	33.12	35.21	35.50
1900	16.51	16.94	18.22	18.64	20.31	21.13	22.34	23.52	24.30	25.07	25.26	26.58	27.13	29.11	31.16	32.15	32.48	34.05	36.12	36.40
2000	17.07	17.52	18.84	19.27	20.99	21.83	23.07	24.28	25.07	25.86	26.05	27.39	27.95	29.94	32.00	32.99	33.31	34.87	36.89	-
2200	18.11	18.58	19.97	20.42	22.21	23.09	24.37	25.62	26.44	27.24	27.44	28.79	29.36	31.35	33.38	34.33	34.64	-	-	-
2400	19.02	19.50	20.95	21.42	23.26	24.16	25.46	26.73	27.55	28.35	28.55	29.89	30.45	32.39	-	-	-	-	-	-
2600	19.78	20.28	21.76	22.24	24.11	25.02	26.33	27.59	28.40	29.18	29.37	30.68	-	-	-	-	-	-	-	-
2800	20.40	20.91	22.40	22.89	24.76	25.66	26.95	28.17	-	-	-	-	-	-	-	-	-	-	-	-
3000	20.86	21.38	22.87	23.35	25.19	26.06	-	-	-	-	-	-	-	-	-	-	-	-	-	-
3200	21.16	21.67	23.14	23.61	-	-	-	-	-	-	-	-	-	-	-	-	-	-	-	-

## "5VX" Gripnotch® Belts

("Drive Ratio Correction" Must Be Added to Ratings Listed Below)

rpm of Smaller Sheave	SHEAVE PITCH DIAMETERS (in.)																			
	4.30	4.50	4.55	4.70	4.80	4.90	5.10	5.30	5.40	5.50	5.70	5.80	5.90	6.10	6.20	6.30	6.50	6.60	6.70	6.90
1160	5.90	6.54	6.71	7.19	7.51	7.83	8.46	9.10	9.42	9.73	10.36	10.68	10.99	11.62	11.93	12.24	12.86	13.17	13.48	14.10
1450	7.08	7.87	8.07	8.66	9.05	9.44	10.22	10.99	11.38	11.76	12.53	12.91	13.30	14.06	14.44	14.82	15.57	15.95	16.32	17.07
1750	8.23	9.16	9.40	10.09	10.55	11.02	11.93	12.85	13.30	13.75	14.66	15.11	15.56	16.45	16.89	17.34	18.22	18.66	19.10	19.97
2900	12.00	13.43	13.78	14.84	15.54	16.24	17.62	18.99	19.66	20.34	21.67	22.33	22.99	24.30	24.94	25.58	26.85	27.48	28.10	29.34
3500	13.57	15.20	15.61	16.82	17.62	18.41	19.98	21.53	22.29	23.05	24.54	25.28	26.01	27.46	28.17	28.87	30.26	30.94	31.62	32.95
300	**	**	**	**	**	**	**	**	**	**	**	**	**	**	**	**	**	**	**	**
400	**	**	**	**	**	**	**	**	**	**	**	**	**	**	**	**	**	**	**	**
500	**	**	**	**	**	**	**	**	**	**	**	**	**	**	**	**	**	**	**	6.69
600	**	**	**	**	**	**	**	**	**	**	**	**	**	**	**	**	**	**	**	7.88
700	**	**	**	**	**	**	5.48	5.88	6.08	6.28	6.67	6.87	7.07	7.47	7.66	7.86	8.25	8.45	8.65	9.04
800	4.33	4.78	4.90	5.24	5.47	5.70	6.15	6.60	6.83	7.05	7.50	7.73	7.95	8.40	8.62	8.85	9.29	9.51	9.73	10.18
900	4.78	5.29	5.41	5.80	6.05	6.30	6.81	7.31	7.57	7.82	8.32	8.57	8.82	9.31	9.56	9.81	10.31	10.55	10.80	11.29
1000	5.22	5.78	5.92	6.34	6.62	6.90	7.46	8.01	8.29	8.56	9.12	9.39	9.67	10.21	10.49	10.76	11.30	11.57	11.85	12.39
1100	5.65	6.26	6.41	6.87	7.18	7.48	8.09	8.70	9.00	9.30	9.90	10.20	10.50	11.09	11.39	11.69	12.28	12.58	12.87	13.46
1200	6.07	6.73	6.90	7.39	7.72	8.05	8.71	9.37	9.69	10.02	10.67	10.99	11.32	11.96	12.28	12.60	13.24	13.56	13.88	14.52
1300	6.48	7.19	7.37	7.91	8.26	8.62	9.32	10.03	10.38	10.73	11.42	11.77	12.12	12.81	13.16	13.50	14.19	14.53	14.87	15.55
1400	6.88	7.65	7.84	8.41	8.79	9.17	9.92	10.67	11.05	11.42	12.17	12.54	12.91	13.65	14.01	14.38	15.11	15.48	15.84	16.57
1500	7.28	8.09	8.29	8.90	9.30	9.71	10.51	11.31	11.71	12.10	12.89	13.29	13.68	14.47	14.86	15.25	16.02	16.41	16.80	17.57
1600	7.66	8.53	8.74	9.38	9.81	10.24	11.09	11.93	12.35	12.77	13.61	14.03	14.44	15.27	15.68	16.10	16.92	17.32	17.73	18.54
1800	8.42	9.37	9.61	10.32	10.80	11.27	12.21	13.15	13.61	14.08	15.00	15.46	15.92	16.84	17.29	17.74	18.65	19.10	19.55	20.44
2000	9.14	10.18	10.45	11.23	11.74	12.26	13.29	14.31	14.82	15.33	16.34	16.84	17.34	18.34	18.83	19.33	20.31	20.80	21.29	22.25
2200	9.83	10.96	11.25	12.09	12.66	13.22	14.33	15.44	15.99	16.53	17.62	18.17	18.71	19.78	20.31	20.84	21.90	22.42	22.95	23.99
2400	10.49	11.71	12.01	12.92	13.53	14.13	15.33	16.51	17.10	17.69	18.85	19.43	20.01	21.15	21.72	22.29	23.41	23.97	24.53	25.63
2600	11.12	12.42	12.75	13.72	14.36	15.00	16.28	17.54	18.16	18.79	20.03	20.64	21.25	22.46	23.06	23.66	24.85	25.44	26.03	27.19
2800	11.72	13.10	13.45	14.48	15.16	15.84	17.18	18.52	19.18	19.83	21.14	21.79	22.43	23.70	24.33	24.96	26.21	26.82	27.43	28.65
3000	12.28	13.75	14.11	15.20	15.91	16.63	18.04	19.44	20.14	20.83	22.19	22.87	23.54	24.87	25.53	26.18	27.48	28.12	28.75	30.01
3200	12.82	14.36	14.74	15.88	16.63	17.38	18.86	20.32	21.04	21.76	23.18	23.89	24.58	25.96	26.65	27.32	28.66	29.32	29.97	31.26
3400	13.33	14.93	15.33	16.52	17.30	18.08	19.62	21.14	21.89	22.63	24.11	24.83	25.55	26.98	27.68	28.38	29.75	30.42	31.09	32.41
3600	13.80	15.47	15.88	17.12	17.93	18.74	20.33	21.90	22.68	23.45	24.96	25.71	26.45	27.91	28.63	29.34	30.74	31.43	32.11	-
3800	14.23	15.97	16.40	17.67	18.51	19.35	20.99	22.61	23.41	24.20	25.75	26.52	27.27	28.76	29.49	30.22	31.64	-	-	-
4000	14.64	16.43	16.87	18.18	19.05	19.91	21.60	23.26	24.07	24.8										

## 5V GRIPBELT® BELTS HORSEPOWER TABLES "5V" SUPER GRIPBELT BELTS

**Table No.1 ("Drive Ratio Correction" Must Be Added to Ratings Listed Below)**

rpm of Smaller Sheave	SHEAVE PITCH DIAMETERS (in.)											DRIVE RATIO CORRECTION									
	13.10	13.70	13.90	14.90	15.50	15.90	16.10	18.50	18.60	20.10	21.10	1.02-1.05	1.06-1.11	1.12-1.18	1.19-1.26	1.27-1.38	1.39-1.57	1.58-1.94	1.95-3.38	3.39-& UP	
1160	28.20	29.68	30.17	32.55	33.93	34.83	35.28	40.27	40.47	43.24	44.94	0.11	0.30	0.53	0.72	0.87	1.02	1.15	1.26	1.33	
1450	32.94	34.55	35.07	37.88	39.00	39.91	40.35	-	-	-	-	0.14	0.38	0.66	0.90	1.09	1.28	1.44	1.57	1.66	
1750	36.67	38.25	38.75	-	-	-	-	-	-	-	-	0.17	0.46	0.80	1.09	1.32	1.55	1.74	1.90	2.01	
2900	-	-	-	-	-	-	-	-	-	-	-	0.28	0.76	1.33	1.80	2.19	2.56	2.88	3.14	3.33	
3500	-	-	-	-	-	-	-	-	-	-	-	0.34	0.92	1.60	2.18	2.64	3.09	3.48	3.79	4.01	
300	13.41	14.63	15.43	-	-	-	-	-	-	-	-	0.03	0.08	0.14	0.19	0.23	0.26	0.30	0.32	0.34	
400	11.48	12.13	12.35	13.43	14.07	14.50	14.71	17.24	17.35	18.90	19.93	0.04	0.10	0.18	0.25	0.30	0.35	0.40	0.43	0.46	
500	13.99	14.79	15.05	16.36	17.14	17.66	17.92	20.97	21.10	22.96	24.19	0.05	0.13	0.23	0.31	0.38	0.44	0.50	0.54	0.57	
600	16.41	17.34	17.65	19.18	20.08	20.68	20.98	24.51	24.65	26.79	28.20	0.06	0.16	0.27	0.37	0.45	0.53	0.60	0.65	0.69	
700	18.74	19.80	20.14	21.87	22.89	23.57	23.91	27.85	28.01	30.39	31.93	0.07	0.18	0.32	0.44	0.53	0.62	0.70	0.76	0.80	
800	20.98	22.15	22.53	24.44	25.57	26.31	26.68	30.99	31.16	33.72	35.38	0.08	0.21	0.37	0.50	0.60	0.71	0.80	0.87	0.92	
900	23.12	24.39	24.81	26.88	28.10	28.90	29.29	33.89	34.08	36.78	38.50	0.09	0.24	0.41	0.56	0.68	0.79	0.89	0.97	1.03	
1000	25.16	26.52	26.97	29.18	30.47	31.32	31.74	36.56	36.75	39.53	41.28	0.10	0.26	0.46	0.62	0.75	0.88	0.99	1.08	1.15	
1100	27.09	28.54	29.01	31.33	32.68	33.57	34.01	38.96	39.16	41.95	43.69	0.11	0.29	0.50	0.68	0.83	0.97	1.09	1.19	1.26	
1200	28.92	30.42	30.92	33.33	34.73	35.63	36.08	41.09	41.28	44.03	-	0.12	0.31	0.55	0.75	0.91	1.06	1.09	1.30	1.38	
1300	30.62	32.18	32.69	35.16	36.58	37.50	37.95	42.91	43.10	-	-	0.13	0.34	0.59	0.81	0.98	1.15	1.29	1.41	1.49	
1400	32.20	33.80	34.32	36.82	38.24	39.16	39.61	-	-	-	-	0.14	0.37	0.64	0.87	1.06	1.24	1.39	1.52	1.61	
1500	33.65	35.27	35.79	38.29	39.70	40.60	41.03	-	-	-	-	0.15	0.39	0.69	0.93	1.13	1.32	1.49	1.62	1.72	
1600	34.97	36.58	37.10	39.57	40.94	-	-	-	-	-	-	0.16	0.42	0.73	1.00	1.21	1.41	1.59	1.73	1.84	
1700	36.14	37.74	38.25	-	-	-	-	-	-	-	-	0.17	0.45	0.78	1.06	1.28	1.50	1.69	1.84	1.95	
1800	37.16	38.72	-	-	-	-	-	-	-	-	-	0.18	0.47	0.82	1.12	1.36	1.59	1.79	1.95	2.06	
1900	-	-	-	-	-	-	-	-	-	-	-	0.19	0.50	0.87	1.18	1.43	1.68	1.89	2.06	2.18	
2000	-	-	-	-	-	-	-	-	-	-	-	0.19	0.52	0.91	1.24	1.51	1.77	1.99	2.17	2.29	
2200	-	-	-	-	-	-	-	-	-	-	-	0.21	0.58	1.10	1.37	1.66	1.94	2.19	2.38	2.52	
2400	-	-	-	-	-	-	-	-	-	-	-	0.23	0.63	1.10	1.49	1.81	2.12	2.39	2.60	2.75	
2600	-	-	-	-	-	-	-	-	-	-	-	0.25	0.68	1.19	1.62	1.96	2.30	2.58	2.82	2.98	
2800	-	-	-	-	-	-	-	-	-	-	-	0.27	0.73	1.28	1.74	2.11	2.47	2.78	3.03	3.21	
3000	-	-	-	-	-	-	-	-	-	-	-	0.29	0.79	1.37	1.87	2.26	2.65	2.98	3.25	3.44	
3200	-	-	-	-	-	-	-	-	-	-	-	0.31	0.84	1.46	1.99	2.41	2.83	3.18	3.47	3.67	

## "5VX" SUPER GRIPBELT BELTS

("Drive Ratio Correction" Must Be Added to Ratings Listed Below)

rpm of Smaller Sheave	SHEAVE PITCH DIAMETERS (in.)											DRIVE RATIO CORRECTION									
	7.00	7.10	7.40	7.50	7.90	8.10	8.40	8.70	9.10	9.15	9.50	1.02-1.03	1.04-1.06	1.07-1.09	1.10-1.13	1.14-1.18	1.19-1.25	1.26-1.35	1.36-1.57	1.58-& UP	
1160	14.40	14.71	15.63	15.93	17.15	17.75	18.65	19.55	20.74	20.89	21.92	0.09	0.19	0.28	0.37	0.46	0.56	0.65	0.74	0.84	
1450	17.44	17.81	18.92	19.29	20.76	21.48	22.57	23.64	25.07	25.24	26.47	0.12	0.23	0.35	0.46	0.58	0.70	0.81	0.93	1.04	
1750	20.41	20.84	22.13	22.56	24.26	25.10	26.35	27.59	29.23	29.43	30.84	0.14	0.28	0.42	0.56	0.70	0.84	0.98	1.12	1.26	
2900	29.95	30.56	32.35	32.94	35.24	36.36	38.01	-	-	-	-	0.23	0.46	0.70	0.93	1.16	1.39	1.62	1.86	2.09	
3500	33.60	-	-	-	-	-	-	-	-	-	-	0.28	0.56	0.84	1.12	1.40	1.68	1.96	2.24	2.52	
300	**	**	**	**	**	**	**	**	**	**	**	0.02	0.05	0.07	0.10	0.12	0.14	0.17	0.19	0.22	
400	**	**	**	**	**	**	**	**	7.55	8.01	8.07	8.47	0.03	0.06	0.10	0.13	0.16	0.19	0.22	0.26	0.29
500	6.83	6.98	7.40	7.55	8.12	8.40	8.82	9.25	9.81	9.88	10.37	0.04	0.08	0.12	0.16	0.20	0.24	0.28	0.32	0.36	
600	8.05	8.22	8.72	8.89	9.56	9.90	10.40	10.90	11.57	11.65	12.23	0.05	0.10	0.14	0.19	0.24	0.29	0.34	0.38	0.43	
700	9.23	9.43	10.01	10.21	10.98	11.37	11.94	12.52	13.28	13.38	14.04	0.06	0.11	0.17	0.22	0.28	0.34	0.39	0.45	0.50	
800	10.40	10.62	11.28	11.50	12.37	12.81	13.46	14.10	14.97	15.07	15.82	0.06	0.13	0.19	0.26	0.32	0.38	0.45	0.51	0.58	
900	11.54	11.78	12.52	12.76	13.73	14.21	14.94	15.66	16.61	16.73	17.56	0.07	0.14	0.22	0.29	0.36	0.43	0.50	0.58	0.65	
1000	12.66	12.93	13.73	14.00	15.07	15.60	16.39	17.18	18.23	18.36	19.27	0.08	0.16	0.24	0.32	0.40	0.48	0.56	0.64	0.72	
1100	13.76	14.05	14.92	15.22	16.38	16.95	17.81	18.67	19.61	19.95	20.93	0.09	0.18	0.26	0.35	0.44	0.53	0.62	0.70	0.79	
1200	14.83	15.15	16.10	16.41	17.66	18.28	19.21	20.13	21.35	21.50	22.56	0.10	0.19	0.29	0.38	0.48	0.58	0.67	0.77	0.86	
1300	15.89	16.23	17.24	17.58	18.92	19.58	20.57	21.56	22.86	23.03	24.16	0.10	0.21	0.31	0.42	0.52	0.62	0.73	0.83	0.94	
1400	16.93	17.29	18.37	18.73	20.15	20.86	21.91	22.96	24.34	24.51	25.71	0.11	0.22	0.34	0.45	0.56	0.67	0.78	0.90	1.01	
1500	17.95	18.33	19.47	19.85	21.36	22.10	23.22	24.32	25.78	25.96	27.23	0.12	0.24	0.36	0.48	0.60	0.72	0.84	0.96	1.08	
1600	18.95	19.35	20.55	20.95	22.54	23.32	24.50	25.66	27.19	27.38	28.70	0.13	0.26	0.38	0.51	0.64	0.77	0.90	1.02	1.15	
1800	20.88	21.33	22.65	23.09	24.82	25.68	26.96	28.22	29.89	30.09	31.53	0.14	0.29	0.43	0.58	0.72	0.86	1.01	1.15	1.30	
2000	22.74	23.22	24.65	25.12	26.99	27.92	29.29	30.65	32.43	32.65	34.18	0.16	0.32	0.48	0.64	0.80	0.96	1.12	1.28	1.44	
2200	24.50	25.02	26.55	27.05	29.05	30.03	31.49	32.93	34.81	35.04	36.65	0.18	0.35	0.53	0.70	0.88	1.06	1.23	1.41	1.58	
2400	26.18	26.72	28.34	28.88	30.98	32.02	33.55	35.05	37.01	37.25	38.91	0.19	0.38	0.58	0.77	0.96	1.15	1.34	1.54	1.73	
2600	27.76	28.33	30.03	30.59	32.79	33.86	35.45	37.01	39.02	39.27	40.97	0.21	0.42	0.62	0.83	1.04	1.25	1.46	1.67	1.87	
2800	29.25	29.84	31.61	32.18	34.46	35.57	37.20	38.79	-	-	-	0.22	0.45	0.67	0.90	1.12	1.35	1.57	1.79	2.02	
3000	30.63	31.24	33.06	33.66	35.99	37.12	-	-	-	-	-	0.24	0.48	0.72	0.96	1.20	1.44	1.68	1.92	2.16	
3200	31.90	32.53	34.39	35.00	-	-	-	-	-	-	-	0.26	0.51	0.77	1.02	1.28	1.54	1.79	2.05	2.30	
3400	33.06	33.71	-	-	-	-	-	-	-	-	-	0.27	0.54	0.82	1.09	1.36	1.63	1.91	2.18	2.45	
3600	-	-	-	-	-	-	-	-	-	-	-	0.29	0.58	0.86	1.15	1.44	1.73	2.02	2.31	2.59	
3800	-	-	-	-	-	-	-	-	-	-	-	0.30	0.61	0.91	1.22	1.52	1.83	2.13	2.43	2.74	
4000	-	-	-	-	-	-	-	-	-	-	-	0.32	0.64	0.96	1.28	1.60	1.92	2.24	2.56	2.88	
4200	-	-	-	-	-	-	-	-	-	-	-	0.34	0.67	1.01	1.34	1.68	2.02	2.35	2.69	3.02	
4400	-	-	-	-	-	-	-	-	-	-	-	0.35	0.70	1.06	1.41	1.76	2.11	2.47	2.82	3.17	
4600	-	-	-	-	-	-	-	-	-	-	-	0.37	0.74	1.10	1.47	1.84					

## 8V GRIPBELT® BELTS HORSEPOWER TABLES "8V" SUPER GRIPBELT BELTS

**Table No.1 ("Drive Ratio Correction" Must be Added to Ratings Listed Below)**

rpm of Smaller Sheave	SHEAVE PITCH DIAMETERS (in.)										
	12.30	13.00	13.80	14.80	15.80	16.80	17.80	18.80	19.80	21.00	22.20
725	30.48	33.85	37.65	42.34	46.94	51.47	55.91	60.27	64.54	69.55	74.42
870	35.00	38.88	43.24	48.58	53.81	58.90	63.87	68.70	73.39	78.82	84.04
960	37.57	41.73	46.39	52.09	57.63	63.01	68.21	73.24	78.09	83.66	88.93
1160	42.58	47.26	52.48	58.78	64.81	70.58	76.06	81.25	86.12	91.55	-
1450	47.98	53.14	58.78	65.42	71.58	77.24	-	-	-	-	-
1750	50.91	56.13	61.66	-	-	-	-	-	-	-	-
200	**	**	**	**	**	**	18.61	20.10	21.58	23.35	25.11
300	14.65	16.20	17.97	20.17	22.36	24.53	26.69	28.83	30.97	33.51	36.03
400	18.73	20.75	23.04	25.89	28.72	31.52	34.30	37.05	39.79	43.04	46.26
500	22.59	25.05	27.84	31.30	34.72	38.11	41.46	44.78	48.06	51.96	55.79
600	26.23	29.11	32.37	36.40	40.38	44.31	48.18	52.00	55.77	60.22	64.58
700	29.66	32.93	36.63	41.19	45.68	50.09	54.43	58.69	62.87	67.77	72.56
800	32.88	36.51	40.62	45.66	50.60	55.44	60.17	64.79	69.30	74.56	79.65
900	35.87	39.85	44.32	49.78	55.12	60.32	65.37	70.27	75.03	80.51	85.76
1000	38.65	42.92	47.71	53.55	59.22	64.70	69.99	75.08	79.97	85.56	90.82
1100	41.18	45.72	50.79	56.94	62.86	68.54	73.98	79.17	84.09	89.62	94.73
1200	43.46	48.23	53.53	59.92	66.02	71.82	77.31	82.47	87.30	-	-
1300	45.47	50.44	55.92	62.46	68.66	74.48	79.91	84.94	-	-	-
1400	47.21	52.32	57.92	64.55	70.75	76.49	-	-	-	-	-
1500	48.66	53.87	59.53	66.16	72.27	-	-	-	-	-	-
1600	49.80	55.06	60.72	67.26	-	-	-	-	-	-	-
1700	50.62	55.87	61.46	-	-	-	-	-	-	-	-
1800	51.11	56.29	-	-	-	-	-	-	-	-	-
1900	51.24	56.30	-	-	-	-	-	-	-	-	-
2000	51.00	-	-	-	-	-	-	-	-	-	-

\*\*Belt Speeds are very low other types of drives should be considered; consult Application Engineering.

## "8V" SUPER GRIPBELT BELTS

**("Drive Ratio Correction" Must Be Added to Ratings Listed Below)**

rpm of Smaller Sheave	DRIVE RATIO CORRECTION									
	1.02-1.05	1.06-1.11	1.12-1.18	1.19-1.26	1.27-1.38	1.39-1.57	1.58-1.94	1.95-3.38	3.39-and UP	
725	0.34	0.93	1.62	2.20	2.66	3.12	3.51	3.83	4.05	
870	0.41	1.11	1.94	2.64	3.20	3.74	4.21	4.59	4.86	
960	0.45	1.23	2.14	2.91	3.53	4.13	4.65	5.07	5.37	
1160	0.54	1.48	2.58	3.52	4.26	4.99	5.62	6.12	6.48	
1450	0.68	1.85	3.23	4.40	5.33	6.24	7.02	7.65	8.10	
1750	0.82	2.24	3.90	5.31	6.43	7.53	8.48	9.23	9.78	
200	0.09	0.26	0.45	0.61	0.73	0.86	0.97	1.06	1.12	
300	0.14	0.38	0.67	0.91	1.10	1.29	1.45	1.58	1.68	
400	0.19	0.51	0.89	1.21	1.47	1.72	1.94	2.11	2.24	
500	0.23	0.64	1.11	1.52	1.84	2.15	2.42	2.64	2.79	
600	0.28	0.77	1.34	1.82	2.20	2.58	2.91	3.17	3.35	
700	0.33	0.89	1.56	2.12	2.57	3.01	3.39	3.69	3.91	
800	0.38	1.02	1.78	2.43	2.94	3.44	3.88	4.22	4.47	
900	0.42	1.15	2.00	2.73	3.31	3.87	4.36	4.75	5.03	
1000	0.47	1.28	2.23	3.03	3.67	4.30	4.84	5.28	5.59	
1100	0.52	1.41	2.45	3.34	4.04	4.73	5.33	5.80	6.15	
1200	0.56	1.53	2.67	3.64	4.41	5.16	5.81	6.33	6.71	
1300	0.61	1.66	2.90	3.94	4.78	5.59	6.30	6.86	7.27	
1400	0.66	1.79	3.12	4.24	5.14	6.03	6.78	7.39	7.82	
1500	0.70	1.92	3.34	4.55	5.51	6.46	7.27	7.92	8.38	
1600	0.75	2.04	3.56	4.85	5.88	6.89	7.75	8.44	8.94	
1700	0.80	2.17	3.79	5.15	6.25	7.32	8.23	8.97	9.50	
1800	0.84	2.30	4.01	5.46	6.61	7.75	8.72	9.50	10.06	
1900	0.89	2.43	4.23	5.76	6.98	8.18	9.20	10.03	10.62	
2000	0.94	2.56	4.46	6.06	7.35	8.61	9.69	10.55	11.18	

## FHP GRIPBELT® BELTS HORSEPOWER TABLES

**Table No.1 "3L" and "4L" FHP Belts**

rpm Smaller Sheave	"3L" Sheave Pitch Diameters (in.)										"4L" Sheave Pitch Diameters (in.)										
	1.25	1.5	1.75	2.0	2.5	3.0	3.5	4.0	4.5	5.0	1.25	1.5	2.0	2.5	3.0	3.5	4.0	4.5	5.0	5.5	6.0
860	.06	.10	.14	.17	.25	.32	.36	.40	.43	.48	.06	.09	.19	.34	.50	.66	.81	.89	.97	1.04	1.11
1140	.07	.12	.16	.21	.30	.40	.45	.50	.54	.59	.07	.11	.22	.43	.65	.85	1.01	1.11	1.20	1.20	1.37
1720	.09	.15	.23	.29	.43	.55	.61	.67	.73	.78	.09	.14	.29	.60	.88	1.17	1.37	1.49	1.61	1.70	1.78
3450	.12	.22	.35	.47	.69	.86	.91	.92	.90	.84	.07	.14	.35	.86	1.32	1.73	1.98	1.99	1.93	1.79	-
200	-	-	-	-	-	-	-	-	-	.15	-	-	-	-	-	-	-	-	.28	.30	.34
400	-	-	-	-	-	.19	.22	.25	.26	-	-	.13	.18	.26	.32	.43	.49	.51	.55	.60	-
600	-	.09	.11	.13	.18	.25	.27	.30	.33	.36	.06	.08	.16	.25	.38	.48	.60	.67	.72	.78	.84
800	.06	.10	.13	.16	.23	.30	.34	.38	.41	.45	.06	.09	.18	.32	.48	.62	.76	.84	.91	.98	1.05
1000	.07	.11	.15	.19	.28	.35	.41	.45	.49	.53	.07	.10	.20	.39	.58	.76	.91	1.00	1.09	1.16	1.24
1200	.07	.12	.17	.22	.31	.41	.47	.52	.56	.61	.07	.11	.23	.45	.68	.88	1.05	1.15	1.24	1.33	1.42
1400	.08	.13	.19	.25	.36	.47	.52	.58	.64	.68	.08	.12	.25	.51	.76	1.00	1.18	1.29	1.39	1.48	1.58
1600	.08	.14	.21	.28	.40	.52	.58	.65	.70	.75	.08	.13	.28	.57	.84	1.10	1.31	1.42	1.53	1.63	1.72
1800	.09	.15	.24	.30	.44	.56	.64	.69	.75	.80	.09	.14	.29	.61	.91	1.20	1.42	1.54	1.65	1.75	1.82
2000	.10	.16	.25	.33	.47	.61	.68	.75	.80	.84	.10	.15	.30	.66	.98	1.30	1.53	1.65	1.76	1.83	1.91
2200	.10	.17	.26	.35	.51	.66	.73	.79	.84	.88	.10	.16	.32	.70	1.04	1.38	1.63	1.75	1.83	1.91	1.97
2400	.10	.18	.28	.37	.54	.70	.77	.83	.87	.90	.10	.16	.33	.74	1.10	1.46	1.72	1.82	1.91	1.97	2.00
2600	.11	.19	.30	.39	.58	.73	.81	.86	.90	.92	.09	.17	.34	.77	1.15	1.52	1.79	1.89	1.96	1.99	1.99
2800	.11	.20	.32	.41	.61	.77	.84	.88	.91	.92	.09	.16	.34	.80	1.20	1.59	1.85	1.94	1.99	2.00	1.95
3000	.12	.20	.33	.43	.63	.80	.87	.90	.92	.92	.08	.16	.35	.82	1.25	1.64	1.91	1.97	2.00	1.97	1.89
3500	.12	.22	.35	.47	.70	.87	.91	.92	.90	.82	.07	.14	.35	.86	1.33	1.74	1.99	1.99	1.91	1.78	-
4000	.13	.23	.37	.50	.74	.90	.92	.89	.79	-	.04	.12	.33	.88	1.37	1.79	1.98	1.89	-	-	-
4500	.14	.23	.38	.53	.77	.92	.90	.79	-	-	.01	.10	.30	.88	1.37	1.76	1.88	-	-	-	-
5000	.13	.23	.39	.54	.79	.92	.82	-	-	-	-	.06	.25	.85	1.32	1.66	-	-	-	-	-
5500	.13	.22	.39	.54	.78	.88	.72	-	-	-	-	.01	.19	.79	1.22	1.51	-	-	-	-	-
6000	.12	.22	.38	.54	.77	.79	-	-	-	-	-	-	.11	.70	1.07	-	-	-	-	-	-
6500	.11	.20	.37	.52	.72	.72	-	-	-	-	-	-	.01	.56	.92	-	-	-	-	-	-
7000	.09	.19	.36	.49	.64	-	-	-	-	-	-	-	-	.39	-	-	-	-	-	-	-
7500	.06	.16	.33	.45	.54	-	-	-	-	-	-	-	-	.20	-	-	-	-	-	-	-
8000	.04	.12	.29	.40	-	-	-	-	-	-	-	-	-	-	-	-	-	-	-	-	-
8500	.01	.08	.24	.33	-	-	-	-	-	-	-	-	-	-	-	-	-	-	-	-	-
9000	-	.01	.18	.23	-	-	-	-	-	-	-	-	-	-	-	-	-	-	-	-	-

**Table No.2 "5L" FHP Belts**

rpm Smaller Sheave	Sheave Pitch Diameters (in.)											
	2.2	2.5	3.0	3.4	3.9	4.4	4.9	5.4	5.9	6.4	6.9	7.4
860	2.4	.31	.44	.68	.91	1.19	1.38	1.50	1.61	1.71	1.80	1.89
1140	.30	.37	.56	.84	1.14	1.48	1.72	1.85	1.96	2.07	2.17	2.27
1720	.36	.45	.71	1.07	1.52	1.95	2.26	2.39	2.50	2.59	2.68	2.71
3450	.28	.35	.67	1.21	1.84	2.36	2.56	2.30	-	-	-	-
200	-	-	-	-	-	-	-	.44	.51	.56	.60	-
400	.13	.16	.26	.43	.48	.59	.73	.80	.85	.91	.98	1.04
600	.19	.23	.34	.51	.68	.87	1.03	1.12	1.21	1.28	1.36	1.44
800	.23	.29	.42	.64	.86	1.12	1.31	1.41	1.52	1.62	1.72	1.80
1000	.27	.34	.50	.92	1.04	1.34	1.56	1.69	1.80	1.90	2.00	2.09
1200	.31	.38	.58	.92	1.19	1.53	1.79	1.91	2.03	2.14	2.24	2.33
1400	.33	.41	.64	.96	1.33	1.71	1.99	2.12	2.23	2.34	2.44	2.53
1600	.35	.42	.69	1.03	1.45	1.86	2.17	2.29	2.41	2.51	2.60	2.66
1800	.36	.46	.72	1.10	1.56	2.01	2.32	2.44	2.55	2.64	2.69	2.73
2000	.38	.47	.76	1.15	1.65	2.12	2.45	2.57	2.66	2.71	2.73	2.71
2200	.38	.47	.77	1.19	1.72	2.23	2.57	2.66	2.72	2.73	2.69	2.65
2400	.37	.47	.78	1.22	1.78	2.31	2.65	2.72	2.73	2.69	2.55	2.45
2600	.37	.46	.78	1.25	1.83	2.37	2.71	2.73	2.69	2.55	2.42	2.22
2800	.36	.44	.77	1.26	1.86	2.41	2.73	2.70	2.60	2.42	2.22	-
3000	.38	.42	.75	1.25	1.88	2.42	2.71	2.63	2.46	2.22	-	-
3500	.27	.34	.66	1.21	1.82	2.34	2.53	2.26	-	-	-	-
4000	.18	.22	.52	1.08	1.64	2.08	2.22	-	-	-	-	-
4500	.04	.07	.32	.84	1.32	-	-	-	-	-	-	-
5000	-	-	.07	.48	.96	-	-	-	-	-	-	-

Ratings are not shown for belt speeds in excess of 5000 feet per minute. Drives requiring higher belt speeds should be referred to Application Engineering.

**How to Use These Tables**

The basic horsepower rating for a "4L" belt on a drive in which the small sheave is 5.0 PD. at 1720 rpm is 1.61 Horsepower. This value must be corrected by the correction Factor for Loss in Arc of Contact from Table No. 3, page 89. For instance, if the other sheave in the drive is 11.0 PD. and the center distance is 15.0", the loss in Arc of Contact is:

$$\frac{(11.0 - 5.0) 57}{15} \text{ or } 22.8^\circ$$

The correction factor is .94, therefore the corrected horsepower is 1.61 x .94 = 1.51 per belt.

### VARIABLE SPEED DRIVES

#### FOR CHANGING SPEEDS FREQUENTLY, RAPIDLY AND EFFICIENTLY

The Browning® line of variable speed drives comprises one of the world's most complete selections of in-stock variable speed drives, including variable pitch sheaves through 230 hp.

Sheaves for Browning variable speed drives are available in finished bore or bushing types, for use with exclusive Browning Split Taper® design or Q-D® bushings. They're offered in Classical (A, B, & C), "358" narrow groove, wide range and fractional horsepower types. MVP® sheaves are dynamically-balanced to ensure smooth, vibration-free performance. Select from:

- **VL and VM single groove sheaves**, pitch diameter range 1.6-4.7", for light duty applications up to 5hp.
- **VP single and double groove sheaves**, pitch diameter range 3.4-8.4", designed for heavier duty service up to 30 hp.
- **MVP multiple groove sheaves** (up to 5 grooves available), pitch diameter range 3.4-17.2", for multiple belt drives up to 230 hp.

Choose also from a full range of fixed pitch and companion sheaves, V-belts, adjustable motor bases, motors and drivers, to perform almost any power transmission service.



**VL, VM, VP variable  
speed sheaves**



**MVP variable speed  
sheave**



**MVP® companion  
sheave**

## Variable Speed Sheaves

Belt Size	Type		No. of Grooves	Pitch Dia. Range	Bore Range
A-B	MVP®	Bushing Type	2-5	A-5.9-7.0 7.9-9.0 B-6.0-7.4 8.0-9.4	3/4-2 5/8
		Finished Bore	2-5	A-3.4-4.5 6.9-8.0 B3.5-4.9 7.0-8.4	7/8-2 1/8
C	MVP	Bushing Type	2-4	7.5-9.7 11.5-13.7	1-2 5/8
		Finished Bore	5	7.5-9.7 11.5-13.7	1 7/8-3 3/8
5v	MVP	Finished Bore Narrow Groove	3-5*	8.1-9.5 11.1-12.5	1 7/8-3 3/8

\*3-Groove is Bushing Type, Bore Range 1 - 2 5/8"

## Variable Pitch Sheaves

Type			3L	4L or A	5L or B	5V
Single Groove Cast Iron	Finished Bore 1/2"-7/8"	VL	1.6"-2.4" 1.8-2.7	1.9-2.9 2.8-3.8		
		VM		1.9-2.9 3.4-4.4	2.4"-3.2" 3.7-4.7	
	Finished Bore 1/2-1 1/8	1VP	1.4-2.2 5.1-5.9	1.9-2.9 5.7-6.7	2.4-3.2 5.8-7.0	4.9-8.4
Two Groove Cast Iron	Finished Bore 1/2-2 1/8	2VP	1.9-2.7 5.1-5.9	2.0-3.0 6.7-7.7	2.5-3.3 6.8-7.0	7.2-8.4

## Companion Sheaves

<b>A-B</b>	MVP®	Bushing Type	3-5	A-4.6-37.5 B-5.0-38.0	1/2"-3 3/4"
<b>C</b>	MVP	Bushing Type	3-5	8.0-50.0	1-5 1/2
<b>5V</b>	MVP	Narrow Groove Bushing Type	3-5	7.9-49.9	1 1/8-5 1/2

For additional product information, visit [www.regalrexnord.com/Browning](http://www.regalrexnord.com/Browning)



## STOCK SHEAVE LISTING

**Table No.2 1 and 2 Groove "A-B" Variable Pitch Sheaves**

Datum Diameter (in.)		1 Groove			2 Grooves		
		Finished Bore	Finished Bore	Finished Bore	Bushed	Finished Bore	Bushed
"A" Belts	"B" Belts	Page 111	Page 109	Page 110		Page 114	Page 115
1.9-2.9	2.4-3.2	1 VL34	1VP34	-	-	-	-
2.0-3.0	2.5-3.3	-	-	2VP36	-	-	-
2.4-3.4	2.7-3.7	1 VL40	1VP40	-	-	-	-
2.6-3.6	2.9-3.9	-	-	2VP42	-	-	-
2.8-3.8	3.1-4.1	1 VL44	1VP44	-	-	-	-
3.4-4.4	3.7-4.7	1VM50	1VP50	2VP50	-	-	-
3.4-4.5	3.5-4.9	-	-	-	-	2MVP35B49	-
3.9-5.0	4.0-5.4	-	-	-	-	2MVP40B54	-
4.0-5.0	4.3-5.3	-	1VP56	2VP56	-	-	-
4.2-5.2	4.3-5.5	-	1VP60	2VP60	-	-	-
4.4-5.5	4.5-5.9	-	-	-	-	2MVP45B59	-
4.6-5.6	4.9-5.9	-	1VP62	2VP62	-	-	-
4.7-5.7	4.8-6.0	-	1VP65	2VP65	-	-	-
4.9-6.0	5.0-6.4	-	-	-	-	2MVP50B64	-
5.2-6.2	5.5-6.5	-	1VP68	2VP68	-	-	-
5.3-6.3	5.4-6.6	-	1VP71	2VP71	-	-	-
5.4-6.5	5.5-6.9	-	-	-	-	2MVP55B69	-
5.7-6.7	5.8-7.0	-	1VP75	2VP75	2V58B70P	-	-
5.9-7.0	6.0-7.4	-	-	-	-	-	2MVP60B74P
6.7-7.7	6.8-8.0	-	2VP84	-	-	-	-
6.9-8.0	7.0-8.4	-	-	-	-	-	2MVP70B84P
7.9-9.0	8.0-9.4	-	-	-	-	-	2MVP80B94Q

**Table No.2 3 to 5 Groove "A-B" Variable Pitch Sheaves**

Datum Diameter (in.)		3 Grooves		4 Grooves		5 Grooves	
		Finished Bore	Bushed	Finished Bore	Bushed	Finished Bore	Bushed
"A" Belts	"B" Belts	Page 114	Page 115	Page 114	Page 115	Page 114	Page 115
3.4-4.5	3.5-4.9	3MVP35B49	-	4MVP35B49	-	5MVP35B49	-
3.9-5.0	4.0-5.4	3MVP40B54	-	4MVP40B54	-	5MVP40B54	-
4.4-5.5	4.5-5.0	3MVP45B59	-	4MVP45B59	-	5MVP45B59	-
4.9-6.0	5.0-6.4	3MVP50B64	-	4MVP50B64	-	5MVP50B64	-
5.4-6.5	5.5-6.9	3MVP55B69	-	4MVP55B69	-	5MVP55B69	-
5.9-7.0	6.0-7.4	3MVP60B74	3MVP60B74P	4MVP60B74	4MVP60B74P	5MVP60B74	5MVP60B74P
6.9-8.0	7.0-8.4	3MVP70B84	3MVP70B84P	4MVP70B84	4MVP70B84P	5MVP70B84	5MVP70B84P
7.9-9.0	8.0-9.4	-	3MVP80B94Q	-	4MVP80B94Q	-	5MVP80B94Q

**Table No.3 2 to 5 Groove "C" Variable Pitch Sheaves**

Datum Diameter "C" Belts (in.)	2 Grooves		3 Grooves	4 Grooves	5 Grooves
	Bushed	Bushed	Bushed	Bushed	Finished Bore
	Page 118	Page 118	Page 118	Page 118	Page 119
7.2-9.0	2V72C90Q	-	-	-	-
7.5-9.7	-	2MVP75C97Q	3MVP75C97Q	4MVP75C97Q	5MVP75C97
8.0-10.2	-	-	3MVP80C102Q	-	-
8.2-10.0	2V82C100Q	-	-	-	-
8.5-10.7	-	2MVP85C107Q	3MVP85C107Q	4MVP85C107Q	5MVP85C107
9.0-11.2	-	-	3MVP90C112Q	-	-
9.2-11.0	2V92C110Q	-	-	-	-
9.5-11.7	-	2MVP95C117Q	3MVP95C117Q	4MVP95C117Q	5MVP95C117
10.5-12.7	-	2MVP105C127Q	3MVP105C127Q	4MVP105C127Q	5MVP105C127
11.5-13.7	-	2MVP115C137Q	3MVP115C137Q	4MVP115C137Q	5MVP115C137

**Table No.4 1 to 5 Groove "5V" Variable Pitch Sheaves**

Pitch Diameter "5V" Belts (in.)	1 Groove	2 Grooves	3 Grooves	4 Grooves	5 Grooves
	Finished Bore	Finished Bore	Finished Bore	Finished Bore	Finished Bore
	Page 109	Page 110	Page 122	Page 122	Page 122
5.3 - 6.3	1VP62	2VP62	-	-	-
5.2 - 6.4	1VP65	2VP65	-	-	-
5.9 - 6.9	1VP68	2VP68	-	-	-
5.8 - 7.0	1VP71	2VP71	-	-	-
6.2 - 7.4	1VP75	2VP75	-	-	-
7.2 - 8.4	-	2VP84	-	-	-
8.1 - 9.5	-	-	3MVP815V95Q	4MVP815V95	5MVP815V95
9.1 - 10.5	-	-	3MVP915V105Q	4MVP915V105	5MVP915V105
10.1 - 11.5	-	-	3MVP1015V115Q	4MVP1015V115	5MVP1015V115
11.1 - 12.5	-	-	3MVP1115V125Q	4MVP1115V125	5MVP1115V125

# STOCK SHEAVE LISTING

**Table No.1 "A-B" Companion Sheaves**

Datum Diameter (in.)		3 Grooves	4 Grooves	5 Grooves
"A"	"B"	Page 116	Page 116	Page 117
4.6	5.0	3MVB50P(P1)	4MVB50Q(Q2)	5MVB50Q(Q2)
5.0	5.4	3MVB54P(P1)	4MVB54Q(Q2)	5MVB54Q(Q2)
5.6	6.0	3MVB60P(P1)	4MVB60Q(Q2)	5MVB60Q(Q2)
6.0	6.4	3MVB64P(P1)	4MVB64Q(Q2)	5MVB64Q(Q2)
6.6	7.0	3MVB70Q(Q1)	4MVB70Q(Q2)	5MVB70R(R2)
7.0	7.4	3MVB74Q(Q1)	4MVB74Q(Q2)	5MVB74R(R2)
7.6	8.0	3MVB80Q(Q1)	4MVB80Q(Q2)	5MVB80R(R2)
8.2	8.6	3MVB86Q(Q1)	4MVB86Q(Q2)	5MVB86R(R2)
8.6	9.0	3MVB90Q(Q1)	4MVB90Q(Q2)	5MVB90R(R2)
9.0	9.4	3MVB94Q(Q1)	4MVB94Q(Q2)	5MVB94R(R2)
10.6	11.0	3MVB110Q(Q1)	4MVB110R(R1)	5MVB110R(R2)
12.0	12.4	3MVB124Q(Q1)	4MVB124R(R1)	5MVB124R(R2)
13.2	13.6	3MVB136Q(Q1)	4MVB136R(R1)	5MVB136R(R2)
15.0	15.4	3MVB154Q(Q1)	4MVB154R(R1)	5MVB154R(R2)
15.0	15.4	3MVB154R(R1)	-	-
18.0	18.4	3MVB184Q(Q1)	4MVB184R(R1)	5MVB184R(R2)
18.0	18.4	3MVB184R(R1)	-	-
19.5	20.0	3MVB200R(R1)	4MVB200R(R1)	5MVB200R(R2)
24.5	25.0	3MVB250R(R1)	4MVB250R(R1)	5MVB250R(R2)
29.5	30.0	3MVB300R(R1)	4MVB300R(R1)	5MVB300R(R2)
37.5	38.0	3MVB380R(R1)	4MVB380R(R1)	5MVB380R(R2)



**Table No.2 "C" Companion Sheaves**

Datum Dia. "C" (in.)	3 Grooves	4 Grooves	5 Grooves
	Page 120	Page 120	Page 121
8.0	3MVC80Q(Q2)	4MVC80Q(Q2)	5MVC80R(R2)
8.6	3MVC86Q(Q2)	4MVC86Q(Q2)	5MVC86R(R2)
9.0	3MVC90Q(Q2)	4MVC90Q(Q2)	5MVC90R(R2)
9.6	3MVC96Q(Q2)	4MVC96Q(Q2)	5MVC96R(R2)
10.0	3MVC100Q(Q2)	4MVC100Q(Q2)	5MVC100R(R2)
10.6	3MVC106Q(Q2)	4MVC106Q(Q2)	5MVC106R(R2)
11.0	3MVC110Q(Q2)	4MVC110R(R2)	5MVC110R(R2)
12.0	3MVC120Q(Q2)	4MVC120R(R2)	5MVC120R(R2)
13.0	3MVC130Q(Q2)	4MVC130R(R2)	5MVC130R(R2)
14.0	3MVC140R(R1)	4MVC140R(R2)	5MVC140R(R2)
16.0	3MVC160R(R1)	4MVC160R(R2)	5MVC160R(R2)
18.0	3MVC180R(R1)	4MVC180R(R2)	5MVC180R(S2)
20.0	3MVC200R(R1)	4MVC200R(R2)	5MVC200R(S2)
24.0	3MVC240R(R1)	4MVC240R(R2)	5MVC240R(S2)
27.0	3MVC270R(R2)	4MVC270R(R2)	5MVC270R(S2)
30.0	3MVC300R(R2)	4MVC300R(R2)	5MVC300R(S2)
36.0	3MVC360R(R2)	4MVC360R(R2)	5MVC360R(S2)
44.0	3MVC440U(U0)	-	5MVC440U(U0)
50.0	3MVC500U(U0)	4MVC500U(U0)	5MVC500U(U0)

**Table No.3 Bushing Bores**

Bushing	Bores Range (in.)
P1	1/2 - 1 3/4
Q1	3/4 - 2 11/16
Q2	1 - 2 5/8
R1	1 1/8 - 3 3/4
R2	1 3/8 - 3 5/8
S1	1 11/16 - 4 1/4
S2	1 7/8 - 4 3/16
U0	2 3/8 - 5 1/2
U1	2 3/8 - 5 1/2

**Table No.4 "5V" Companion Sheaves**

Pitch Dia. "5V" (in.)	3 Grooves	4 Grooves	5 Grooves
	Page 123	Page 123	Page 124
7.9	3MV5V80R(R1)	4MV5V80R(R1)	5MV5V80R(R2)
8.4	3MV5V85R(R1)	4MV5V85R(R1)	5MV5V85R(R2)
8.9	3MV5V90R(R1)	4MV5V90R(R1)	5MV5V90R(R2)
9.15	3MV5V92R(R1)	4MV5V92R(R1)	5MV5V92R(R2)
9.65	3MV5V97R(R1)	4MV5V97R(R1)	5MV5V97R(R2)
10.2	3MV5V103R(R1)	4MV5V103R(R1)	5MV5V103R(R2)
10.8	3MV5V109R(R1)	4MV5V109R(R1)	5MV5V109R(R2)
11.7	3MV5V118R(R1)	4MV5V118R(R1)	5MV5V118R(S1)
12.4	3MV5V125R(R1)	4MV5V125R(R1)	5MV5V125R(S1)
13.1	3MV5V132R(R1)	4MV5V132R(R1)	5MV5V132R(S1)
13.9	3MV5V140R(R1)	4MV5V140R(R1)	5MV5V140R(S1)
14.9	3MV5V150R(R1)	4MV5V150R(R1)	5MV5V150R(S1)
15.9	3MV5V160R(R1)	4MV5V160R(R1)	5MV5V160R(S1)
17.9	3MV5V180R(R1)	4MV5V180R(R1)	5MV5V180R(S1)
19.9	3MV5V200R(R1)	4MV5V200R(R1)	5MV5V200R(S1)
21.1	3MV5V212S(S1)	4MV5V212S(S1)	5MV5V212S(U0)
23.9	3MV5V240S(S1)	4MV5V240S(S1)	5MV5V240S(U0)
27.9	3MV5V280S(S1)	4MV5V280S(S1)	5MV5V280S(U0)
29.9	3MV5V300S(S1)	4MV5V300S(S1)	5MV5V300S(U0)
37.4	3MV5V375U(U0)	4MV5V375S(S1)	5MV5V375S(U0)
43.9	3MV5V440U(U0)	4MV5V440U(U0)	5MV5V440U(U0)
49.9	3MV5V500U(U0)	4MV5V500U(U0)	5MV5V500U(U0)

Bushing number is shown in parenthesis after Sheave Part Number.

For additional product information, visit [www.regalrexnord.com/Browning](http://www.regalrexnord.com/Browning)

### 1VP CAST IRON SHEAVES

Single Groove Variable Pitch Sheaves for "3L", "4L", "5L", "A", "B" and "5V" Belts

#### Dimensions (in.)

Part No.	O.D.	OL	Wt. Lbs.
1VP25	2.50	1 11/16	.8
1VP30	2.87	1 11/16	.9
1VP34	3.15	1 7/8	1.2
1VP40	3.75	1 7/8	1.7
1VP44	4.15	1 7/8	1.9
1VP44	4.15	2 5/32	2.6
1VP50	4.75	1 15/16	1.9
1VP50	4.75	2 5/32	2.9
1VP56	5.35	1 15/16	2.7
1VP56	5.35	2 5/32	3.4
1VP60	6.00	2 7/32	5.5
1VP62	5.95	2 7/32	5.7
1VP65	6.50	2 7/32	5.8
1VP68	6.55	2 7/32	6.4
1VP71	7.10	2 7/32	6.8
1VP75	7.50	2 7/32	7.3

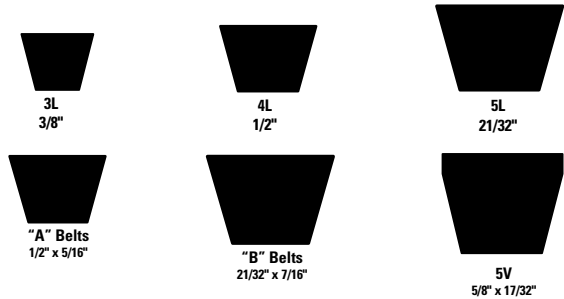

**Robust Casting Design**



#### Stock Sizes - Finished Bore (in.)

PART No.	DIAMETER RANGE																STOCK BORES MARKED "X"									
	"3L" BELTS				"4L" OR "A" BELTS				"5L" OR "B" BELTS				"5V" BELTS				1/2	5/8	3/4	7/8	1	1 1/8	1 1/4	1 3/8	1 5/8	
	MIN. PITCH	TURNS OPEN	MAX. PITCH	TURNS OPEN	MIN. DATUM	TURNS OPEN	MAX. DATUM	TURNS OPEN	MIN. DATUM	TURNS OPEN	MAX. DATUM	TURNS OPEN	MIN. PITCH	TURNS OPEN	MAX. PITCH	TURNS OPEN										
1VP25	1.6	4	2.4	0	-	-	-	-	-	-	-	-	-	-	-	-	x	-	-	-	-	-	-	-	-	-
1VP30	1.8	4	2.7	0	-	-	-	-	-	-	-	-	-	-	-	-	x	x	x	-	-	-	-	-	-	-
1VP34	1.7	4	2.5	0	1.9	5	2.9	0	2.4	5	3.2	1	-	-	-	-	x	x	x	x	-	-	-	-	-	-
1VP40	2.3	4	3.1	0	2.4	5	3.4	0	2.7	6	3.7	1	-	-	-	-	x	x	x	x	-	-	-	-	-	-
1VP44	2.7	4	3.5	0	2.8	5	3.8	0	3.1	6	4.1	1	-	-	-	-	x	x	x	x	-	-	-	-	-	-
1VP44	2.7	4	3.5	0	2.8	5	3.8	0	3.1	6	4.1	1	-	-	-	-	-	-	x	x	x	-	-	-	-	-
1VP50	3.3	4	4.1	0	3.4	5	4.4	0	3.7	6	4.7	1	-	-	-	-	x	x	x	-	-	-	-	-	-	-
1VP50	3.3	4	4.1	0	3.4	5	4.4	0	3.7	6	4.7	1	-	-	-	-	-	-	x	x	x	-	-	-	-	-
1VP56	3.9	4	4.7	0	4.0	5	5.0	0	4.3	6	5.3	1	-	-	-	-	x	x	x	-	-	-	-	-	-	-
1VP56	3.9	4	4.7	0	4.0	5	5.0	0	4.3	6	5.3	1	-	-	-	-	-	-	x	x	x	-	-	-	-	-
1VP60	-	-	-	-	4.2	5	5.2	0	4.3	6	5.5	0	4.7	6	5.9	0	-	-	x	x	-	x	-	x	x	x
1VP62	-	-	-	-	4.2	5	5.2	0	4.3	6	5.5	0	4.7	6	5.9	0	-	-	x	x	x	x	x	x	x	x
1VP65	-	-	-	-	4.7	5	5.7	0	4.8	6	6.0	0	5.2	6	6.4	0	-	-	x	x	-	x	-	x	x	x
1VP68	-	-	-	-	4.7	5	5.7	0	4.8	6	6.0	0	5.2	6	6.4	0	-	-	x	x	x	x	x	x	x	-
1VP71	-	-	-	-	5.3	5	6.3	0	5.4	6	6.6	0	5.8	6	7.0	0	-	-	x	x	-	x	-	x	x	x
1VP75	-	-	-	-	5.7	5	6.7	0	5.8	6	7.0	0	6.2	6	7.4	0	-	-	x	x	-	x	-	x	x	x

All fitted with Hollow Head Setscrews.  
Any standard Browning® Sheave can be used as a Companion Sheave.

## 2VP CAST IRON SHEAVES

Two Groove Variable Pitch Sheaves for "3L", "4L", "5L", "A", "B" and "5V" Belts

### Dimensions (in.)

Part No.	O.D.	OL	Wt. Lbs.
2VP36	3.35	3	2.6
2VP42	3.95	3	3.5
2VP50	4.75	3	5.4
2VP56	5.35	3	6.6
2VP60	6.00	3 1/4	10.2
2VP62	5.95	3 1/4	10.5
2VP65	6.5	3 1/4	11.6
2VP68	6.55	3 1/4	12.3
2VP71	7.1	3 1/4	13.4
2VP75	7.5	3 1/4	15.5
2VP84	8.5	3.3	21.6

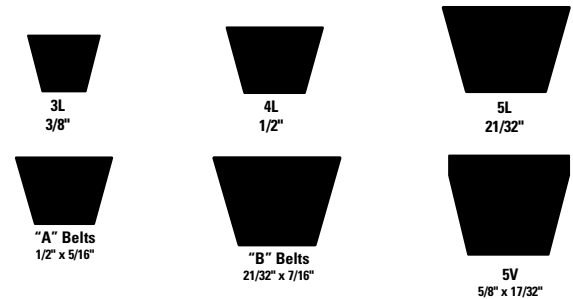

**Robust Casting Design**



### Stock Sizes - Finished Bore (in.)

PART No.	DIAMETER RANGE																STOCK BORES MARKED "X"											
	"3L" BELTS				"4L" OR "A" BELTS				"5L" OR "B" BELTS				"5V" BELTS				1/2	5/8	3/4	7/8	1	1 1/8	1 1/4	1 3/8	1 5/8	1 7/8	2 1/8	
	MIN. PITCH	TURNS OPEN	MAX. PITCH	TURNS OPEN	MIN. DA-TUM	TURNS OPEN	MAX. DA-TUM	TURNS OPEN	MIN. DA-TUM	TURNS OPEN	MAX. DA-TUM	TURNS OPEN	MIN. PITCH	TURNS OPEN	MAX. PITCH	TURNS OPEN												
2VP36	1.9	4	2.7	0	2.0	5	3.0	0	2.5	5	3.3	1	-	-	-	-	x	x	x	x	-	x	-	-	-	-	-	
2VP42	2.5	4	3.3	0	2.6	5	3.6	0	2.9	6	3.9	1	-	-	-	-	-	x	x	x	x	x	-	-	-	-	-	
2VP50	3.3	4	4.1	0	3.4	5	4.4	0	3.7	6	4.7	1	-	-	-	-	-	x	x	x	x	x	-	-	-	-	-	
2VP56	3.9	4	4.7	0	4.0	5	5.0	0	4.3	6	5.3	1	-	-	-	-	-	x	x	x	x	x	-	-	-	-	-	
2VP60	-	-	-	-	4.2	5	5.2	0	4.5	6	5.5	0	4.7	6	5.9	0	-	-	x	x	x	x	x	-	-	-	-	-
2VP62	-	-	-	-	4.2	5	5.2	0	4.5	6	5.5	1	4.7	6	5.9	0	-	-	x	x	x	x	x	x	x	x	-	-
2VP65	-	-	-	-	4.7	5	5.7	0	4.8	6	6.0	0	5.2	6	6.4	0	-	-	x	x	-	x	-	x	x	-	-	
2VP68	-	-	-	-	4.7	5	5.7	0	4.8	6	6.0	1	5.2	6	6.4	0	-	-	-	x	x	x	x	-	-	-	-	-
2VP71	-	-	-	-	5.3	5	6.3	0	5.4	6	6.6	0	5.8	6	7.0	0	-	-	x	x	-	x	-	x	x	-	-	
2VP75	-	-	-	-	5.7	5	6.7	0	5.8	6	7.0	0	6.2	6	7.4	0	-	-	x	x	-	x	-	x	x	-	-	
2VP84	-	-	-	-	6.7	5	7.7	0	6.8	6	8.0	0	7.2	6	8.4	0	-	-	x	x	x	x	x	x	x	x	-	-

All fitted with Hollow Head Setscrews.  
Any standard two groove Browning® Sheave can be used as a Companion Sheave.

For additional product information, visit [www.regalrexnord.com/Browning](http://www.regalrexnord.com/Browning)

### VL AND VM CAST IRON SHEAVES

#### Stock "VL" and "VM" Variable Pitch Sheaves

Part No.	O.D.	F		G		L	Wt. Lbs.
		Max.	Min.	Max.	Min.		
1VL25	2.5	25/32	17/32	5/8	3/8	1 11/16	.8
1VL30	2.87	25/32	17/32	5/8	3/8	1 11/16	.9
1VL34	3.15	31/32	21/32	13/16	1/2	1 7/8	1.2
1VL40	3.75	1 1/32	21/32	7/8	1/2	1 7/8	1.7
1VL44	4.15	1 1/32	21/32	7/8	1/2	1 7/8	1.9
1VM50	4.75	1 1/16	1 1/16	7/8	1/2	1 15/16	1.9

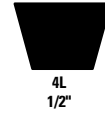

"VL" and "VM" Sheaves are furnished with standard keyseats and hollow head setscrews. Available in both Single pack and "BULK" pack quantities; 20 pieces per carton.

#### Stock Sizes - Finished Bore (in.)

PART No.	DIAMETER RANGE												STOCK BORES MARKED "X"			
	"3L" BELTS				"4L" OR "A" BELTS				"5L" OR "B" BELTS				1/2	5/8	3/4	7/8
	MIN. PITCH	TURNS OPEN	MAX. PITCH	TURNS OPEN	MIN. DATUM	TURNS OPEN	MAX. DATUM	TURNS OPEN	MIN. DATUM	TURNS OPEN	MAX. DATUM	TURNS OPEN				
1VL25	1.6	4	2.4	0	-	-	-	-	-	-	-	-	x	x	-	-
1VL30	1.8	4	2.7	0	-	-	-	-	-	-	-	-	x	x	-	-
1VL34	1.7	4	2.5	0	1.9	5	2.9	0	2.4	5	3.2	1	x	x	x	-
1VL40	2.3	4	3.1	0	2.4	5	3.4	0	2.7	6	3.7	1	x	x	x	x
1VL44	2.7	4	3.5	0	2.8	5	3.8	0	3.1	6	4.1	1	x	x	x	x
1VM50	3.3	4	4.1	0	3.4	5	4.4	0	3.7	6	4.7	1	x	x	x	x

#### Standard Keyseats (in.)

Bore Range	Keyseat
3/4 to 7/8	3/16 x 3/32
15/16 to 1 1/4	1/4 x 1/8
1 5/16 to 1 3/8*	5/16 x 5/32
1 7/16 to 1 3/4	3/8 x 3/16

Low Priced, High Production  
Cast Iron Sheaves  
For Any Light Application

## MVP® SHEAVES

The Browning® MVP Sheave consists of a series of angular faced flanges which are bolted to a fixed flange and another series of angular faced flanges which are bolted to a threaded collar. When the threaded collar is turned clockwise it moves the angular faced flanges closer together causing the belts to ride higher in the groove, increasing the pitch diameter. When turned counter clockwise it moves the flanges apart allowing the belt to ride lower in the groove, decreasing the pitch diameter. The threaded flange is equipped with a locking collar so that when the desired pitch diameter can be attained by turning the threaded collar, the movable flanges can be securely locked in place. The pitch diameter is infinitely adjustable between the minimum and maximum setting.

And..... All Browning MVP Sheaves are dynamically balanced.



- More power in less space than a traditional multiple sheave.
- Smaller, lighter weight drives are possible than that of other sheave competitors.
- Bearing overhang is not as great as with conventional V-belts..

### A-B VARIABLE SPEED SHEAVES

Stock Finished Bore MVP® Sheaves for "A" and "B" Belts  
Dynamically Balanced



**Table No.1 Specifications (in.)**

DIAMETER			Part Number	Dimensions			Stock Bores Marked "X"							Wt. Lbs.
Datum Range		Outside		O.L.	Face Width		7/8	1 1/8	1 3/8	1 5/8	1 7/8	2 1/8	2 3/8	
"A" Belts	"B" Belts				Max.	Min.								
<b>2 Grooves</b>														
3.4-4.5	3.5-4.9	5.18	2MVP35B49	3 5/8	2 5/16	1 15/16	X	X	X	-	-	-	-	9.8
3.9-5.0	4.0-5.4	5.68	2MVP40B54	3 5/8	2 5/16	1 15/16	-	X	X	X	-	-	-	12.5
4.4-5.5	4.5-5.9	6.18	2MVP45B59	3 5/8	2 5/16	1 15/16	-	X	X	X	-	-	-	14.3
4.9-6.0	5.0-6.4	6.68	2MVP50B64	3 5/8	2 5/16	1 15/16	-	X	X	X	-	-	-	18.1
5.4-6.5	5.5-6.9	7.18	2MVP55B69	3 5/8	2 5/16	1 15/16	-	X	X	X	-	-	-	19.8
<b>3 Grooves</b>														
3.4-4.5	3.5-4.9	5.18	3MVP35B49	4 3/4	3 7/16	3 1/16	-	X	X	-	-	-	-	12.5
3.9-5.0	4.0-5.4	5.68	3MVP40B54	4 3/4	3 7/16	3 1/16	-	X	X	X	-	-	-	16.3
4.4-5.5	4.5-5.9	6.18	3MVP45B59	4 3/4	3 7/16	3 1/16	-	X	X	X	-	-	-	18.3
4.9-6.0	5.0-6.4	6.68	3MVP50B64	4 3/4	3 7/16	3 1/16	-	-	X	X	X	-	-	22.9
5.4-6.5	5.5-6.9	7.18	3MVP55B69	4 3/4	3 7/16	3 1/16	-	-	X	X	X	-	-	24.5
5.9-7.0	6.0-7.4	7.68	3MVP60B74	4 3/4	3 7/16	3 1/16	-	-	-	-	X	-	-	29.3
6.9-8.0	7.0-8.4	8.68	3MVP70B84	4 3/4	3 7/16	3 1/16	-	-	-	-	X	-	-	36.8
<b>4 Grooves</b>														
3.4-4.5	3.5-4.9	5.18	4MVP35B49	5 7/8	4 9/16	4 3/16	-	X	X	-	-	-	-	15
3.9-5.0	4.0-5.4	5.68	4MVP40B54	5 7/8	4 9/16	4 3/16	-	X	X	X	-	-	-	20.5
4.4-5.5	4.5-5.9	6.18	4MVP45B59	5 7/8	4 9/16	4 3/16	-	-	X	X	X	-	-	22.8
4.9-6.0	5.0-6.4	6.68	4MVP50B64	5 7/8	4 9/16	4 3/16	-	-	X	X	X	-	-	29.8
5.4-6.5	5.5-6.9	7.18	4MVP55B69	5 7/8	4 9/16	4 3/16	-	-	X	X	X	-	-	31.1
5.9-7.0	6.0-7.4	7.68	4MVP60B74	5 7/8	4 9/16	4 3/16	-	-	-	-	X	-	-	38.8
6.9-8.0	7.0-8.4	8.68	4MVP70B84	5 7/8	4 9/16	4 3/16	-	-	-	-	X	X	-	47.0
<b>5 Grooves</b>														
3.4-4.5	3.5-4.9	5.18	5MVP35B49	7	5 11/16	5 5/16	-	-	X	-	-	-	-	18.3
3.9-5.0	4.0-5.4	5.68	5MVP40B54	7	5 11/16	5 5/16	-	-	-	X	X	-	-	23.9
4.4-5.5	4.5-5.9	6.18	5MVP45B59	7	5 11/16	5 5/16	-	-	-	X	X	-	-	26.3
4.9-6.0	5.0-6.4	6.68	5MVP50B64	7	5 11/16	5 5/16	-	-	-	X	X	-	-	35.3
5.4-6.5	5.5-6.9	7.18	5MVP55B69	7	5 11/16	5 5/16	-	-	-	X	X	X	-	40.1
5.9-7.0	6.0-7.4	7.68	5MVP60B74	7	5 11/16	5 5/16	-	-	-	-	X	X	-	44.1
6.9-8.0	7.0-8.4	8.68	5MVP70B84	7	5 11/16	5 5/16	-	-	-	-	X	X	-	53.0

**Table No.2 Standard Keyseats**

Bore (in.)	Keyseat (in.)
7/8	3/16 x 3/32
1 1/8	1/4 x 1/8
1 3/8	5/16 x 5/32
1 5/8	3/8 x 3/16
1 7/8, 2 1/8	1/2 x 1/4

Browning® finished bore MVP Sheaves are furnished with standard keyseats and two hollow head setscrews. Datum diameter is infinitely adjustable within the datum range, .233" change per turn of the adjusting ring.

## A-B VARIABLE SPEED SHEAVES

Stock Bushed Type MVP® Sheaves for "A" and "B" Belts  
Dynamically Balanced



**Table No.1 Specifications (in.)**

DIAMETER		Outside	PART NUMBER		DIMENSIONS	Wt. Less Bush
Datum Range			Sheave	Bushing	O.L.	
"A" Belts	"B" Belts					
<b>2 Grooves</b>						
5.9-7.0	6.0-7.4	7.68	2MVP60B74P	P2	3 5/8	23.5
6.9-8.0	7.0-8.4	8.68	2MVP70B84P	P2	3 5/8	28.1
7.9-9.0	8.0-9.4	9.68	2MVP80B94Q	Q2	3 5/8	36.1
<b>3 Grooves</b>						
5.9-7.0	6.0-7.4	7.68	3MVP60B74P	P2	4 3/4	29.5
6.9-8.0	7.0-8.4	8.68	3MVP70B84P	P2	4 3/4	35.9
7.9-9.0	8.0-9.4	9.68	3MVP80B94Q	Q2	4 3/4	45.5
<b>4 Grooves</b>						
5-7.0	6.0-7.4	7.68	4MVP60B74P	P3	5 7/8	37.8
6.9-8.0	7.0-8.4	8.68	4MVP70B84P	P3	5 7/8	46.4
7.9-9.0	8.0-9.4	9.68	4MVP80B94Q	Q2	5 7/8	54.4
<b>5 Grooves</b>						
5.9-7.0	6.0-7.4	7.68	5MVP60B74P	P3	7	42.6
6.9-8.0	7.0-8.4	8.68	5MVP70B84P	P3	7	52.5
7.9-9.0	8.0-9.4	9.68	5MVP80B94Q	Q3	7	60.5

Datum diameter is infinitely adjustable within the datum range, .233" change per turn of the adjusting ring.



**Table No.2 Bushing Bores**

Bushing No.	Bore Range (in.)
P2	3/4 - 1 3/4
P3	1 1/8 - 1 5/8
Q2	1 - 2 5/8
Q3	1 3/8 - 2 1/2

**Table No.3 Standard Keyseats**

Bore Range (in.)	Keyseat (in.)
3/4 - 7/8	3/16 x 3/32
15/16 - 1 1/4	1/4 x 1/8
1 5/16 - 1 3/8	5/16 x 5/32
1 7/16 - 1 3/4	3/8 x 3/16
1 13/16 - 2 1/4	1/2 x 1/4
2 5/16 - 2 5/8	5/8 x 5/16

1 3/8" bore bushings (except P3 and Q3) are available with 3/8" x 3/16" keyseat.

### A-B COMPANION SHEAVES

Stock Companion Sheaves for "A" and "B" Belts

**Table No.1 Specifications**

DIAMETERS (in.)			PART NUMBER		DIMENSIONS (in.)	Wt. Less Bush
Datum "A" Belts	Datum "B" Belts	Outside	Sheave	Bushing	O.L.	
<b>3 Grooves, Face Width = 3 1/4"</b>						
4.6	5.0	5.35	3MVB50P	P1	3 1/2	9.8
5	5.4	5.75	3MVB54P	P1	3 1/2	11.3
5.6	6.0	6.35	3MVB60P	P1	3 1/2	13.8
6	6.4	6.75	3MVB64P	P1	3 1/2	13.6
6.6	7.0	7.35	3MVB70Q	Q1	3 17/32	16.8
7.0	7.4	7.75	3MVB74Q	Q1	3 17/32	16.8
7.6	8.0	8.35	3MVB80Q	Q1	3 17/32	19.5
8.2	8.6	8.95	3MVB86Q	Q1	3 17/32	23.5
8.6	9.0	9.35	3MVB90Q	Q1	3 17/32	22.8
9.0	9.4	9.75	3MVB94Q	Q1	3 17/32	22.5
10.6	11.0	11.35	3MVB110Q	Q1	3 17/32	29.0
12.0	12.4	12.75	3MVB124Q	Q1	3 17/32	31.3
13.2	13.6	13.95	3MVB136Q	Q1	3 17/32	35.4
15.0	15.4	15.75	3MVB154Q	Q1	3 17/32	40.0
15.0	15.4	15.75	3MVB154R	R1	3 25/32	44.6
18.0	18.4	18.75	3MVB184Q	Q1	3 17/32	49.3
18.0	18.4	15.75	3MVB184R	R1	3 25/32	53.5
19.5	20.0	20.35	3MVB200R	R1	3 25/32	61.0
24.5	25.0	25.35	3MVB250R	R1	3 25/32	77.0
29.5	30.0	30.35	3MVB300R	R1	3 25/32	109
37.5	38.0	38.5	3MVB380R	R1	3 25/32	132

**4 Grooves, Face Width = 4 3/8"**

4.6	5.0	5.35	4MVB50Q	Q2	5 13/32	12.1
5	5.4	5.75	4MVB54Q	Q2	5 13/32	15.4
5.6	6.0	6.35	4MVB60Q	Q2	4 13/32	19.1
6	6.4	6.75	4MVB64Q	Q2	4 19/32	23.3
6.6	7.0	7.35	4MVB70Q	Q2	4 19/32	24.8
7.0	7.4	7.75	4MVB74Q	Q2	4 19/32	29.0
7.6	8.0	8.35	4MVB80Q	Q2	4 19/32	26.0
8.2	8.6	8.95	4MVB86Q	Q2	4 19/32	30.0
8.6	9.0	9.35	4MVB90Q	Q2	4 19/32	33.4
9.0	9.4	9.75	4MVB94Q	Q2	4 19/32	35.3
10.6	11.0	11.35	4MVB110Q	R1	4 3/8	39.5
12.0	12.4	12.75	4MVB124Q	R1	4 3/8	42.3
13.2	13.6	13.95	4MVB136Q	R1	4 3/8	47.0
15.0	15.4	15.75	4MVB154R	R1	4 3/8	52.5
15.0	15.4	15.75	4MVB184R	R1	4 3/8	65.0
19.5	18.4	18.75	4MVB200R	R1	4 3/8	73.0
24.5	18.4	15.75	4MVB250R	R1	4 3/8	88.0
29.5	20.0	20.35	4MVB300R	R1	4 3/8	131
37.5	25.0	25.35	4MVB380R	R1	4 3/8	171

**Table No.2 Bushing Bores**

Bushing No.	Bore Range (in.)
P1	1/2 - 1 3/4
Q1	3/4-2 11/16
Q2	1 - 2 5/8
R1	1 1/8-3 3/4



**Table No.3 Standard Keyseats (in.)**

Bore Range	Keyseat	Bore Range	Keyseat
1/2-9/16	1/8 x 1/16	1 13/16 - 2 1/4	1/2 x 1/4
5/8-7/8	3/16 x 3/32	2 5/16-2 3/4	5/8 x 5/16
15/16-1 1/4	1/4 x 1/8	2 13/16 - 3 1/4	3/4 x 3/8
1 5/16- 1 3/8	5/16 x 5/32	3 3/8-3 3/4	7/8 x 7/16
1 7/16-1 3/4	3/8 x 3/16		

1 3/8" bore bushings are available with 3/8" x 3/16" keyseat.

## A-B COMPANION SHEAVES

Stock Companion Sheaves for "A" and "B" Belts

**Table No.1 Specifications**

DIAMETERS (in.)			PART NUMBER		DIMENSIONS (in.)	Wt. Less Bush
Datum "A" Belts	Datum "B" Belts	Outside	Sheave	Bushing	O.L.	
<b>5 Grooves, Face Width = 5 1/2"</b>						
4.6	5.0	5.35	5MVB50Q	Q2	6 17/32	15.2
5.0	5.4	5.75	5MVB54Q	Q2	6 17/32	19.0
5.6	6.0	6.35	5MVB60Q	Q2	5 1/2	22.8
6.0	6.4	6.75	5MVB64Q	Q2	5 1/2	27.6
6.6	7.0	7.35	5MVB70R	R2	5 29/32	31.8
7.0	7.4	7.75	5MVB74R	R2	5 29/32	37.0
7.6	8.0	8.35	5MVB80R	R2	5 29/32	45.3
8.2	8.6	8.95	5MVB86R	R2	5 29/32	51.3
8.6	9.0	9.35	5MVB90R	R2	5 29/32	64.0
9.0	9.4	9.75	5MVB94R	R2	5 29/32	50.5
10.6	11.0	11.35	5MVB110R	R2	5 29/32	66.0
12.0	12.4	12.75	5MVB124R	R2	5 29/32	64.0
13.2	13.6	13.95	5MVB136R	R2	5 29/32	73.5
15.0	15.4	15.75	5MVB154R	R2	5 29/32	81.5
18.0	18.4	18.75	5MVB184R	R2	5 29/32	91.0
19.5	20.0	20.35	5MVB200R	R2	5 29/32	102
24.5	25.0	25.35	5MVB250R	R2	5 29/32	115
29.5	30.0	30.35	5MVB300R	R2	5 29/32	166
37.5	38.0	38.35	5MVB380R	R2	5 29/32	235



**Table No.2 Bushing Bores**

Bushing No.	Bore Range (in.)
Q2	1 - 2 5/8
R2	1 3/8 - 3 5/8

**Table No.3 Standard Keyseats (in.)**

Bore Range	Keyseat	Bore Range	Keyseat
1 - 1 1/4	1/4 x 1/8	2 5/16 - 2 3/4	5/8 x 5/16
1 5/16 - 1 3/8	5/16 x 5/32	2 13/16 - 3 1/4	3/4 x 3/8
1 7/16 - 1 3/4	3/8 x 3/16	3 3/8 - 3 3/4	7/8 x 7/16
1 13/16 - 2 1/4	1/2 x 1/4		

1 3/8" bore bushings are available with 3/8" x 3/16" keyseat.

### C COMPANION SHEAVES

Stock Bushed Type Variable Speed Sheaves for "C" Belts  
Dynamically Balanced



"C" Belts  
7/8" x 17/32"

Table No.1 Two Groove "C" Locking Ring Variable Speed Sheaves

Part Number		O.D. (in.)	Datum Range (in.)				DIMENSIONS (in.)		Wt. Less Bush.
Sheave	Bushing		Min. Pitch	Turns Open	Max. Pitch	Turns Open	O.L.		
2V72C90Q	Q2	9.48	7.2	9	9.0	0	5 1/32	34.4	
2V82C100Q	Q2	10.48	8.2	9	10.0	0	5 1/32	41.0	
2V92C110Q	Q2	11.48	9.2	9	11.0	0	5 1/32	48.4	

Use Browning® Gripbelt® belts and stock 2 Groove Sheaves with these Sheaves.  
D. D. is adjustable on quarter-turn increments; .05" per quarter-turn.  
Q2 Bushing bore range = 1" to 2 5/8".

Table No.2 MVP® Sheaves

DIAMETERS (in.)		PART NUMBER		DIMENSIONS (in.)		Wt. Less Bush.
Datum Range	Outside	Sheave	Bushing	O.L.		
<b>2 Grooves</b>						
7.5 - 9.7	10.06	2MVP75C97Q	Q2	4 5/8		44.6
8.5 - 10.7	11.06	2MVP85C107Q	Q2	4 5/8		51.5
9.5 - 11.7	12.03	2MVP95C117Q	Q2	4 5/8		61.0
10.5 - 12.7	13.06	2MVP105C127Q	Q2	4 5/8		69.5
11.5 - 13.7	14.06	2MVP115C137Q	Q2	4 5/8		81.0
<b>3 Grooves</b>						
7.5 - 9.7	10.06	3MVP75C97Q	Q2	6 9/32		57.5
8.0 - 10.2	10.56	3MVP80C102Q	Q2	6 9/32		63.5
8.5 - 10.7	11.06	3MVP85C107Q	Q2	6 9/32		68.5
9.0 - 11.2	11.56	3MVP90C112Q	Q2	6 9/32		73.5
9.5 - 11.7	12.03	3MVP95C117Q	Q2	6 9/32		78.0
10.5 - 12.7	13.06	3MVP105C127Q	Q2	6 9/32		92.5
11.5 - 13.7	14.06	3MVP115C137Q	Q2	6 2/7		111
<b>4 Grooves</b>						
7.5 - 9.7	10.06	4MVP75C97Q	Q3	7 15/16		74.0
8.5 - 10.7	11.06	4MVP85C107Q	Q3	7 15/16		89.0
9.5 - 11.7	12.03	4MVP95C117Q	Q3	7 15/16		103
10.5 - 12.7	13.06	4MVP105C127Q	Q3	7 15/16		121
11.5 - 13.7	14.06	4MVP115C137Q	Q3	7 15/16		141

Datum diameter is infinitely adjustable within the datum range, .233" change per turn of the adjusting ring.



Table No.2  
Bushing Bores

Bushing No.	Bore Range (in.)
Q2	1 - 2 5/8
Q3	1 3/8 - 2 1/2

Table No.3  
Standard Keyseats (in.)

Bore Range	Keyseat
1 - 1 1/4	1/4 x 1/8
1 5/16 - 1 3/8	5/16 x 5/32
1 7/16 - 1 3/4	3/8 X 3/16
1 13/16 - 2 1/4	1/2 x 1/4
2 5/16 - 2 5/8	5/8 x 5/16
2 7/8	3/4 x 3/8

1 3/8" bore bushings (except Q3)  
also available with 3/8" x 3/16" keyseat.

## C VARIABLE SPEED SHEAVES

Stock Finished Bore MVP® Sheaves for "C" Belts  
Dynamically Balanced



"C" Belts  
7/8" x 17/32"

**Table No.1 Specifications**

DIAMETERS (in.)		Part Number	DIMENSIONS (in.)	STOCK BORES MARKED "X" (in.)					Wt. Lbs.
Datum Range	Outside			O.L.	1 7/8	2 1/8	2 3/8	2 7/8	
"C" Belts			5 Grooves						
7.5 - 9.7	10.06	<b>5MVP75C97</b>	9 19/32	X	X	X	-	-	97
8.5 - 10.7	11.06	<b>5MVP85C107</b>	9 19/32	-	X	X	X	-	115
9.5 - 11.7	12.06	<b>5MVP95C117</b>	9 19/32	-	X	X	X	-	133
10.5 - 12.7	13.06	<b>5MVP105C127</b>	9 19/32	-	-	X	X	-	156
11.5 - 13.7	14.06	<b>5MVP115C137</b>	9 19/32	-	-	X	-	-	180

Browning® Finished Bore MVP Sheaves are furnished with standard keyseats and two hollow head setscrews.  
Datum diameter is infinitely adjustable within the datum range, .233" change per turn of the adjusting ring.



**Table No.2 Standard Keyseats (in.)**

Bore	Keyseat
1 7/8, 2 1/8	1/2 x 1/4
2 3/8	5/8 x 5/16
2 7/8	3/4 x 3/8
3 3/8	7/8 x 7/16

### C COMPANION SHEAVES

MVP® Stock Companion Sheaves for "C" Belts

**Table No.1 Specifications**

DIAMETERS (in.)		PART NUMBER		DIMENSIONS (in.)		Wt. Less Bush.
Datum "C" Belts	Outside	Sheave	Bushing	O.L.		
<b>3 Grooves, Face Width = 4 9/16"</b>						
8.0	8.40	3MVC80Q	Q2	4 11/16		33.5
8.6	9.00	3MVC86Q	Q2	4 11/16		34.0
9.0	9.40	3MVC90Q	Q2	4 11/16		35.5
9.6	10.00	3MVC96Q	Q2	4 11/16		41.5
10.0	10.40	3MVC100Q	Q2	4 11/16		45.8
10.6	11.00	3MVC106Q	Q2	4 11/16		46.8
11.0	11.40	3MVC110Q	Q2	4 11/16		45.8
12.0	12.40	3MVC120Q	Q2	4 11/16		50.3
13.0	13.40	3MVC130Q	Q2	4 11/16		53.0
14.0	14.40	3MVC140R	R1	4 9/16		56.5
16.0	16.40	3MVC160R	R1	4 9/16		67.5
18.0	18.40	3MVC180R	R1	4 9/16		96.5
20.0	20.40	3MVC200R	R1	4 9/16		85.0
24.0	24.40	3MVC240R	R1	4 9/16		101
27.0	27.40	3MVC270R	R1	4 9/16		131
30.0	30.40	3MVC300R	R1	4 9/16		156
36.0	36.40	3MVC360R	R1	4 9/16		200
44.0	44.40	3MVC440U	U0	5 13/16		290
50.0	50.40	3MVC500U	U0	5 13/16		315



**4 Grooves, Face Width = 6 7/32"**

8.0	8.40	4MVC80Q	Q2	6 7/32		43.5
8.6	9.00	4MVC86Q	Q2	6 7/32		43.6
9.0	9.40	4MVC90Q	Q2	6 7/32		45.3
9.6	10.00	4MVC96Q	Q2	6 7/32		52.5
10.0	10.40	4MVC100Q	Q2	6 7/32		56.0
10.6	11.00	4MVC106Q	Q2	6 7/32		56.5
11.0	11.40	4MVC110Q	Q2	6 7/32		56.0
12.0	12.40	4MVC120Q	Q2	6 17/64		71.0
13.0	13.40	4MVC130Q	Q2	6 17/64		72.5
14.0	14.40	4MVC140R	R2	6 17/64		80.0
16.0	16.40	4MVC160R	R2	6 17/64		93.0
18.0	18.40	4MVC180R	R2	6 17/64		105
20.0	20.40	4MVC200R	R2	6 17/64		115
24.0	24.40	4MVC240R	R2	6 17/64		138
27.0	27.40	4MVC270R	R2	6 17/64		157
30.0	30.40	4MVC300R	R2	6 17/64		197
36.0	36.40	4MVC360R	R2	6 17/64		241
50.0	50.40	4MVC500U	U0	6 41/64		420

**Table No.2 Bushing Bores**

Bushing No.	Bore Range (in.)
Q2	1 - 2 5/8
R1	1 7/8 - 3 3/4
R2	1 3/8 - 3 5/8
U0	2 3/8 - 5 1/2

**Table No.3 Standard Keyseats (in.)**

Bore Range	Keyseat	Bore Range	Keyseat
1 - 1 1/4	1/4 x 1/8	2 5/16 - 2 3/4	5/8 x 5/16
1 5/16 - 1 3/8	5/16 x 5/32	2 13/16 - 3 1/4	3/4 x 3/8
1 7/16 - 1 3/4	3/8 x 3/16	3 3/8 - 3 3/4	7/8 x 7/16
1 13/16 - 2 1/4	1/2 x 1/4	3 7/8 - 4 1/2	1 x 1/2
		4 5/8 - 5 1/2	1 1/4 x 5/8

1 3/8" bore bushings (except R2) also available with 3/8" x 3/16" keyseat.

## C COMPANION SHEAVES

MVP® Stock Companion Sheaves for "C" Belts

**Table No.1 Specifications**

DIAMETERS (in.)		PART NUMBER		DIMENSIONS (in.)		Wt. Less Bush.
Datum "C" Belts	Outside	Sheave	Bushing	O.L.		
<b>5 Grooves, Face Width = 7 7/8"</b>						
8.0	8.40	5MVC80R	R2	7 7/8		54
8.6	9.00	5MVC86R	R2	7 7/8		68
9.0	9.40	5MVC90R	R2	7 7/8		72
9.6	10.00	5MVC96R	R2	7 7/8		80
10.0	10.40	5MVC100R	R2	7 7/8		82
10.6	11.00	5MVC106R	R2	7 7/8		84
11.0	11.40	5MVC110R	R2	7 7/8		86
12.0	12.40	5MVC120R	R2	7 7/8		83
13.0	13.40	5MVC130R	R2	7 7/8		93
14.0	14.40	5MVC140R	R2	7 7/8		98
16.0	16.40	5MVC160R	R2	7 7/8		110
18.0	18.40	5MVC180S	S2	8 7/32		156
20.0	20.40	5MVC200S	S2	8 7/32		181
24.0	24.40	5MVC240S	S2	8 7/32		213
27.0	27.40	5MVC270S	S2	8 7/32		235
30.0	30.40	5MVC300S	S2	8 7/32		250
36.0	36.40	5MVC360S	S2	8 7/32		327
44.0	44.40	5MVC440U	U0	7 7/8		384
50.0	50.40	5MVC500U	U0	7 7/8		410

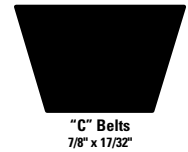

**Table No.2 Bushing Bores**

Bushing No.	Bore Range (in.)
R2	1 3/8 - 3 5/8
S2	1 7/8 - 4 3/16
U0	2 3/8 - 5 1/2
U1	2 3/8 - 5 1/2

**Table No.3 Standard Keyseats (in.)**

Bore Range	Keyseat	Bore Range	Keyseat
1 3/8	5/16 x 5/32	2 13/16 - 3 1/4	3/4 x 3/8
1 7/16 - 1 3/4	3/8 x 3/16	3 3/8 - 3 3/4	7/8 x 7/16
1 13/16 - 2 1/4	1/2 x 1/4	3 7/8 - 4 1/2	1 x 1/2
2 5/16 - 2 3/4	5/8 x 5/16	4 5/8 - 5 1/2	1 1/4 x 5/8

For additional product information, visit [www.regalrexnord.com/Browning](http://www.regalrexnord.com/Browning)



# 3MVP815V95Q - 3MVP1115V125Q 4MVP815V95 X 2 1/8 - 5MVP1115V125 X 3 3/8

## 5V Variable Speed Sheaves

Stock Bushed Type and Finished Bore MVP® Sheaves for "5V" Belts  
Dynamically Balanced

**Table No.1 Specifications - Bushing Type**

DIAMETERS (in.)		PART NUMBER		DIMENSIONS (in.)	Wt. Less Bush.
Pitch Range "5V" Belts	Outside	Sheave	Bushing*	O.L.	
<b>3 Grooves</b>					
8.1 - 9.5	9.6	3MVP815V95Q	Q2	4 3/4	43.0
9.1 - 10.5	10.6	3MVP915V105Q	Q2	4 3/4	55.0
10.1 - 11.5	11.6	3MVP1015V115Q	Q2	4 3/4	70.0
11.1 - 12.5	12.6	3MVP1115V125Q	Q2	4 3/4	88.0

\*Bore range of "Q2" Bushing is 1" - 2 5/8".



**Table No.2 Specifications - Finished Bore Type**

DIAMETERS (in.)		PART NUMBER	DIMENSIONS (in.)	STOCK BORES MARKED "X" (in.)						Wt. Lbs.
Pitch Range "5V" Belts	Outside		O.L.	1 7/8	2 1/8	2 3/8	2 7/8	3 3/8	3 7/8	
<b>4 Grooves</b>										
8.1 - 9.5	9.6	4MVP815V95	5 7/8	-	x	x	-	-	-	65.0
9.1 - 10.5	10.6	4MVP915V105	5 7/8	-	x	x	-	-	-	77.0
10.1 - 11.5	11.6	4MVP1015V115	5 7/8	-	-	-	x	x	-	88.0
11.1 - 12.5	12.6	4MVP1115V125	5 7/8	-	-	-	-	x	-	100
<b>5 Grooves</b>										
8.1 - 9.5	9.6	5MVP815V95	7	-	-	x	x	-	-	75.0
9.1 - 10.5	10.6	5MVP915V105	7	-	-	x	x	-	-	87.0
10.1 - 11.5	11.6	5MVP1015V115	7	-	-	-	x	x	-	100
11.1 - 12.5	12.6	5MVP1115V125	7	-	-	-	x	x	-	120

Browning® Finished Bore MVP Sheaves are furnished with standard keyseats and two hollow head setscrews. Pitch diameter is indefinitely adjustable within the pitch range; .233" change per turn of the adjusting ring.



**Table No.2 Standard Keyseats (in.)**

Bore	Keyseat
1 - 1 1/4	1/4 x 1/8
1 5/16 - 1 3/8	5/16 x 5/16
1 7/16 - 1 3/4	3/8 x 3/16
1 13/16 - 2 1/4	1/2 x 1/4
2 5/16 - 2 5/8	5/8 x 5/16
2 7/8	3/4 x 3/8
3 3/8	7/8 x 7/16

1 3/8" bore bushings (except R2) also available with 3/8" x 3/16" keyseat.

For additional product information, visit [www.regalrexnord.com/Browning](http://www.regalrexnord.com/Browning)

## 5V Companion Sheaves

Stock Companion Sheaves for "5V" Belts

**Table No.1 Specifications**

DIAMETERS (in.)		PART NUMBER		DIMENSIONS (in.)	Wt. Less Bush.
Pitch "5V" Belts	Outside	Sheave	Bushing	O.L.	
<b>3 Grooves , Face Width = 3 1/4"</b>					
7.90	8.00	3MV5V80R	R1	3 25/32	22.2
8.40	8.50	3MV5V85R	R1	3 25/32	26.2
8.90	9.00	3MV5V90R	R1	3 25/32	25.6
9.15	9.25	3MV5V92R	R1	3 25/32	27.6
9.65	9.75	3MV5V97R	R1	3 25/32	29.8
10.20	10.30	3MV5V103R	R1	3 25/32	32.2
10.80	10.90	3MV5V109R	R1	3 25/32	35.4
11.70	11.80	3MV5V118R	R1	3 25/32	38.9
12.40	12.50	3MV5V125R	R1	3 25/32	41.9
13.10	13.20	3MV5V132R	R1	3 25/32	34.9
13.90	14.00	3MV5V140R	R1	3 25/32	37.6
14.90	15.00	3MV5V150R	R1	3 25/32	41.6
15.90	16.00	3MV5V160R	R1	3 25/32	45.7
17.90	18.00	3MV5V180R	R1	3 25/32	51.5
19.90	20.00	3MV5V200R	R1	3 25/32	55.0
21.10	21.20	3MV5V212S	S1	4 3/4	90.5
23.90	24.00	3MV5V240S	S1	4 3/4	99.2
27.90	28.00	3MV5V280S	S1	4 3/4	110
29.90	30.00	3MV5V300S	S1	4 3/4	122
37.40	37.50	3MV5V375U	U0	5 13/32	179
43.90	44.00	3MV5V440U	U0	5 13/32	207
49.90	50.00	3MV5V500U	U0	5 13/32	233
<b>4 Grooves , Face Width = 4 3/8"</b>					
7.90	8.00	4MV5V80R	R1	4 3/8	27.0
8.40	8.50	4MV5V85R	R1	4 3/8	30.9
8.90	9.00	4MV5V90R	R1	4 3/8	30.8
9.15	9.25	4MV5V92R	R1	4 3/8	33.5
9.65	9.75	4MV5V97R	R1	4 3/8	36.0
10.20	10.30	4MV5V103R	R1	4 3/8	38.0
10.80	10.90	4MV5V109R	R1	4 3/8	42.5
11.70	11.80	4MV5V118R	R1	4 3/8	46.1
12.40	12.50	4MV5V125R	R1	4 3/8	53.5
13.10	13.20	4MV5V132R	R1	4 3/8	42.9
13.90	14.00	4MV5V140R	R1	4 3/8	46.1
14.90	15.00	4MV5V150R	R1	4 3/8	50.7
15.90	16.00	4MV5V160R	R1	4 3/8	55.4
17.90	18.00	4MV5V180R	R1	4 3/8	64.2
19.90	20.00	4MV5V200R	R1	4 3/8	73.8
21.10	21.20	4MV5V212S	S1	5 9/32	104
23.90	24.00	4MV5V240S	S1	5 9/32	114
27.90	28.00	4MV5V280S	S1	5 9/32	140
29.90	30.00	4MV5V300S	S1	5 9/32	151
37.40	37.50	4MV5V375U	U0	5 23/32	209
43.90	44.00	4MV5V440U	U0	5 23/32	252
49.90	50.00	4MV5V500U	U0	5 23/32	306



**Table No.2 Bushing Bores**

Bushing No.	Bore Range (in.)
R1	1 1/8 - 3 3/4
S1	1 11/16 - 4 1/4
U0	2 3/8 - 5 1/2

**Table No.3 Standard Keyseats (in.)**

Bore Range	Keyseat
1 1/8 to 1 1/4	1 1/4 x 1/8
1 5/16 & 1 3/8	5/16 x 5/32
1 7/16 to 1 3/4	3/8 x 3/16
1 13/16 to 2 1/4	1/2 x 1/4
2 5/16 to 3 1/4	5/8 x 5/16
2 13/16 to 3 1/4	3/4 x 3/8
3 3/8 to 3 3/4	7/8 x 7/16
3 7/8 to 4 1/2	1 x 1/2
4 5/8 to 5 1/2	1 1/4 x 5/8

### 5V COMPANION SHEAVES

Stock Companion Sheaves for "5V" Belts

**Table No.1 Specifications**

DIAMETERS (in.)		PART NUMBER		DIMENSIONS (in.)		Wt. Less Bush
Pitch "5V" Belts	Outside	Sheave	Bushing	O.L.		
<b>5 Grooves, Face Width = 5 1/2"</b>						
7.90	8.00	<b>5MV5V80R</b>	<b>R2</b>	5 29/32		41.0
8.40	8.50	<b>5MV5V85R</b>	<b>R2</b>	5 29/32		47.9
8.90	9.00	<b>5MV5V90R</b>	<b>R2</b>	5 29/32		44.2
9.15	9.25	<b>5MV5V92R</b>	<b>R2</b>	5 29/32		48.6
9.65	9.75	<b>5MV5V97R</b>	<b>R2</b>	5 29/32		51.6
10.20	10.30	<b>5MV5V103R</b>	<b>R2</b>	5 29/32		55.2
10.80	10.90	<b>5MV5V109R</b>	<b>R2</b>	5 29/32		60.0
11.70	11.80	<b>5MV5V118S</b>	<b>S1</b>	5 27/32		71.6
12.40	12.50	<b>5MV5V125S</b>	<b>S1</b>	5 27/32		79.2
13.10	13.20	<b>5MV5V132S</b>	<b>S1</b>	5 27/32		81.5
13.90	14.00	<b>5MV5V140S</b>	<b>S1</b>	5 27/32		73.6
14.90	15.00	<b>5MV5V150S</b>	<b>S1</b>	5 27/32		78.4
15.90	16.00	<b>5MV5V160S</b>	<b>S1</b>	5 27/32		83.5
17.90	18.00	<b>5MV5V180S</b>	<b>S1</b>	5 27/32		95.4
19.90	20.00	<b>5MV5V200S</b>	<b>S1</b>	5 27/32		105
21.10	21.20	<b>5MV5V212U</b>	<b>U0</b>	6 9/32		135
23.90	24.00	<b>5MV5V240U</b>	<b>U0</b>	6 9/32		151
27.90	28.00	<b>5MV5V280U</b>	<b>U0</b>	6 9/32		186
29.90	30.00	<b>5MV5V300U</b>	<b>U0</b>	6 9/32		199
37.40	37.50	<b>5MV5V375U</b>	<b>U0</b>	6 9/32		239
43.90	44.00	<b>5MV5V440U</b>	<b>U0</b>	6 9/32		250
49.90	50.00	<b>5MV5V500U</b>	<b>U0</b>	6 9/32		325



**Table No.2 Bushing Bores**

Bushing No.	Bore Range (in.)
R2	1 3/8 - 3 5/8
S1	1 11/16 - 4 1/4
S2	1 7/8 - 4 3/16
U0	2 3/8 - 5 1/2
U1	2 3/8 - 5 1/2

**Table No.3 Standard Keyseats (in.)**

Bore Range	Keyseat
1 3/8	5/16 x 5/32
1 7/16 - 1 3/4	3/8 x 3/16
1 13/16 - 2 1/4	1/2 x 1/4
2 5/16 - 2 3/4	5/8 x 5/16
2 13/16 - 3 1/4	3/4 x 3/8
3 3/8 - 3 3/4	7/8 x 7/16
3 7/8 - 4 1/2	1 x 1/2
4 5/8 - 5 1/2	1 1/4 x 5/8

For additional product information, visit [www.regalrexnord.com/Browning](http://www.regalrexnord.com/Browning)

# Browning®

## Bushings...

### **BROWNING® SPLIT TAPER® BUSHING**

- Solid flange to maintain concentric bores
- 3/4" taper per foot – self locking
- Double split barrel for positive clamping
- External key on most sizes for positive drive and greater torque carrying capabilities
- Available in inch, metric and spline bores
- Bore range from 3/8" to 7 7/16"

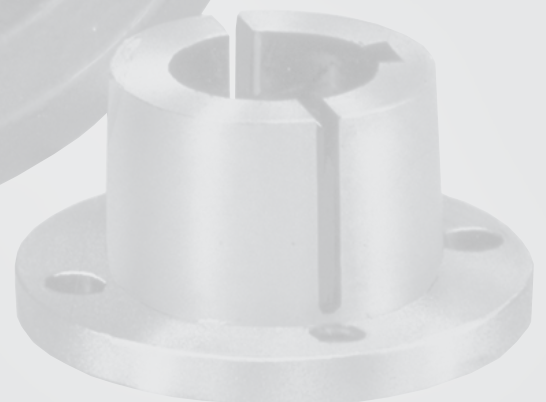

## BROWNING® SPLIT TAPER® & Q-D® BUSHINGS

### THE BROADEST RANGE OF BUSHING SYSTEMS FROM A SINGLE SOURCE

Along with the proven Browning Split Taper Bushing, Q-D bushing systems are available.

Depending on your drive requirements, select from any of these bushing systems, to obtain the most effective combination of components, or choose your own preferred bushing type.

#### Browning Split Taper Bushings

- Lifetime guarantee
- Keyed to both shaft and hub. External key provides positive drive with no torque on the cap screws
- Highest torque carrying capacity in the Browning bushing product line
- Double split barrel assures true concentricity - grips the shaft with positive clamp fit
- Standard sizes - 3/8" - 7 7/16" bore sizes
- Metric Sizes - 10mm - 95mm bore sizes
- Spline Bore - 5/8" - 1 3/8", 6B and 10B, 10 and 21 involute.

Browning multiple groove sheave with split taper bushing

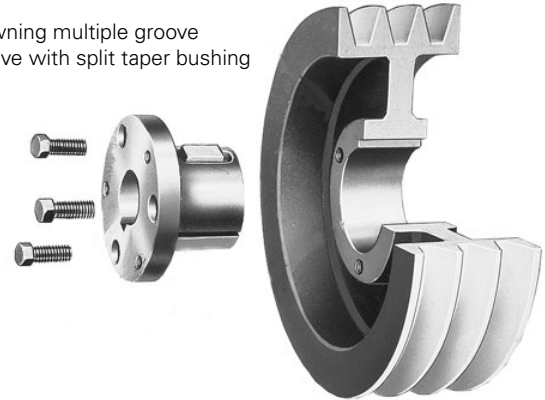

#### Browning Q-D Bushings

- Standard Sizes - 1/2" - 7" bore range.
- Metric Sizes - 24 mm - 100 mm bore range.
- For use with Browning sheaves, sprockets and pulleys; fully interchangeable with competitive Q-D bushings.



Split taper bushing



Q-D bushing

# SPLIT TAPER BUSHINGS

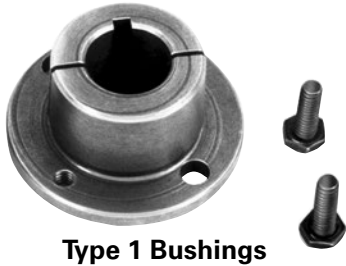

**Type 1 Bushings**



**Type 2 Bushings**

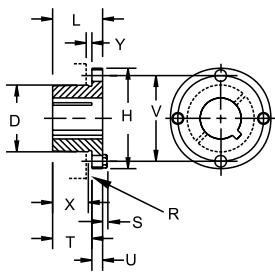

**TYPE 1**

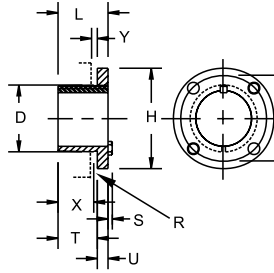

**TYPE 2**

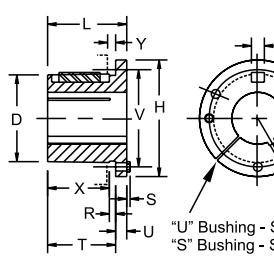

**TYPE 1**

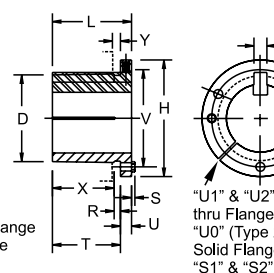

**TYPE 2**

"U" Bushing - Split thru Flange  
"S" Bushing - Solid Flange

"U1" & "U2" Are Split thru Flange.  
"U0" (Type 2 Only) is Solid Flange.  
"S1" & "S2" Are Solid Flange.

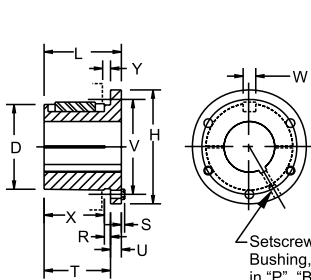

**TYPE 1**

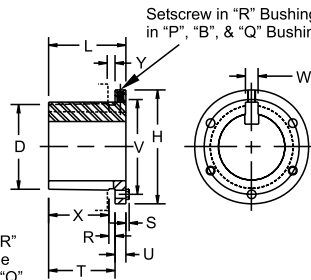

**TYPE 2**

Setscrew in "R" Bushing, none in "P", "B", & "Q" Bushings.

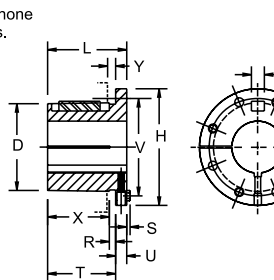

**TYPE 1**

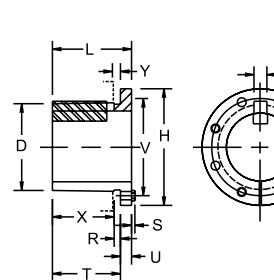

**TYPE 2**

**"W" & "Y" BUSHINGS**

**Table No.1**

**Bushing Specifications**

Part No	Dimensions (in.)												Bore Range (in.)		Cap Screws		Av. Wt. Lbs.	Wrench Torque In-Lbs.
	L	U	T	D		H	V	W	X	Y	R	S	Type 1	Type 2	No.	Size		
				Large End	Small End													
<b>G</b>	1	1/4	3/4	1,172	1,134	2	1 9/16	—	10/16	3/16	1/8	3/16	3/8 - 15/16	1	2	1/4-20 x 5/8	0,5	95
<b>H</b>	1 1/4	1/4	1	1,625	1,571	2 1/2	2	—	14/16	3/16	1/8	3/16	3/8 - 1 1/8	1 7/16 - 1 1/2	2	1/4-20 x 5/8	0,8	95
<b>P1</b>	1 15/16	3/8	1 9/16	1,938	1,856	3	2 7/16	3/8	1 5/16	5/16	1/4	13/64	1/2 - 1 7/16	1 1/2 - 1 3/4	3	5/16-18 x 1	1,3	192
<b>P2</b>	2 15/16	3/8	2 9/16	1,938	1,793	3	2 7/16	3/8	2 5/16	5/16	1/4	13/64	3/4 - 1 7/16	1 1/2 - 1 3/4	3	5/16-18 x 1	1,5	192
<b>P3</b>	4 7/16	3/8	4 1/16	1,938	1,699	3	2 7/16	3/8	3 13/16	5/16	1/4	13/64	1 1/8 - 1 3/8	1,625	3	5/16-18 x 1	1,5	192
<b>B</b>	1 15/16	1/2	1 7/16	2,625	2,557	3 11/16	3 2/16	1/2	1 1/16	3/8	5/16	13/64	1/2 - 1 15/16	2 - 2 7/16	3	5/16-18 x 1 1/4	1,8	192
<b>Q1</b>	2 1/2	1/2	2	2,875	2,769	4 1/8	3 3/8	1/2	1 11/16	3/8	1/4	15/64	3/4 - 2 1/16	2 1/8 - 2 11/16	3	3/8-16 x 1 1/4	3,5	348
<b>Q2</b>	3 1/2	1/2	3	2,875	2,707	4 1/8	3 3/8	1/2	2 11/16	3/8	1/4	15/64	1 - 2 1/16	2 1/8 - 2 5/8	3	3/8-16 x 1 1/4	4,5	348
<b>Q3</b>	5	1/2	4 8/16	2,875	2,613	4 1/8	3 3/8	1/2	4 3/16	3/8	1/4	15/64	1 3/8 - 2 1/16	2 1/8 - 2 1/2	3	3/8-16 x 1 1/4	5,5	348
<b>R1</b>	2 7/8	5/8	2 1/4	4,000	3,877	5 3/8	4 5/8	3/4	1 15/16	5/16	1/4	15/64	1 1/8 - 2 13/16	2 7/8 - 3 3/4	3	3/8-16 x 1 3/4	7,5	348
<b>R2</b>	4 7/8	5/8	4 1/4	4,000	3,752	5 3/8	4 5/8	3/4	3 15/16	5/16	1/4	15/64	1 - 2 1/16	2 1/8 - 2 5/8	3	3/8-16 x 1 3/4	11	348
<b>S1</b>	4 3/8	3/4	3 5/8	4,623	4,420	6 3/8	5 3/8	3/4	3 1/4	7/16	3/8	5/16	1 11/16 - 3 3/16	3 1/4 - 4 1/4	3	1/2-13 x 2 1/4	13,5	840
<b>S2</b>	6 3/4	3/4	6	4,623	4,272	6 3/8	5 3/8	3/4	5 5/8	7/16	3/8	5/16	1 7/8 - 3 3/16	3 1/4 - 4 3/16	3	1/2-13 x 2 1/4	19	840
<b>U0</b>	4 15/16	3/4	4 3/16	5,997	5,768	8 3/8	7	1 1/4	3 11/16	9/16	1/2	3/8	2 3/8 - 4 1/4	4 3/8 - 5 1/2	3	5/8-11 x 2 3/4	27	1680
<b>U1</b>	7 1/8	1 3/16	5 15/16	5,997	5,658	8 3/8	7	1 1/4	5 7/16	9/16	1/2	3/8	2 3/8 - 4 1/4	4 3/8 - 5 1/2	3	5/8-11 x 2 3/4	40	1680
<b>U2</b>	10 1/8	1 3/16	8 15/16	5,997	5,471	8 3/8	7	1 1/4	8 7/16	9/16	1/2	3/8	2 7/16 - 4 1/4	4 3/8 - 5	3	5/8-11 x 2 3/4	50	1680
<b>W1</b>	8 1/4	1 7/16	6 13/16	8,496	8,104	12 1/2	10	1 1/4	6 1/4	9/16	1/2	1/2	3 3/8 - 6 3/16	6 1/4 - 7 7/16	4	3/4-10 x 3	104	3000
<b>W2</b>	11 1/4	1 7/16	9 13/16	8,496	7,916	12 1/2	10	1 1/4	9 1/4	9/16	1/2	1/2	3 3/8 - 6 3/16	6 1/4 - 7 7/16	4	3/4-10 x 3	133	3000
<b>Y0*</b>	11 1/8	2	9 1/8	12,000	11,469	16 1/2	14 1/2	2	8 1/2	11/16	5/8	5/8	6 - 7 15/16	8-10	4	1-8 x 5	270	7200

**Table No.2 - Flange Set Screw**

	Thread	Tightening Torque (in-lb)
R	5/16-18	165
S,U	3/8-16	290
W,Y	1/2-13	620

R1 - 1 1/8, R1 1 3/16, R2 1 3/8, S1 1 11/16, S1 1 3/4 and S2 1 7/8" to 2 1/8" Bushings are steel. U0 and U1 2 3/8" to 3 3/16" and U2 2 7/16" to 3 3/16" are cast iron. "W" and "Y" Bushings are Gray Iron. All other Bushings on this page are either sintered steel or ductile iron.

Contact Application Engineering for clarification.

\*Y0 Bushings are made-to-order.

Note: Taper on all Browning® Split Bushings is 3/4" per foot on diameter.

## BROWNING® SPLIT TAPER® BUSHINGS

Complete Round Shaft Coverage  
Plus Millimeter and Spline Bores

**Table No.1 Stock Inch Bore Bushings**

Stock Bore	Keyseat	G	H	P1	P2	P3	B	Q1	Q2	Q3	R1	R2	S1
3/8	None	X	X	-	-	-	-	-	-	-	-	-	-
7/16	None	X	X	-	-	-	-	-	-	-	-	-	-
1/2	1/8 x 1/16	X	X	X	-	-	X	-	-	-	-	-	-
9/16	1/8 x 1/16	X	X	X	-	-	X	-	-	-	-	-	-
19/32	3/16 x 3/32	-	X	-	-	-	-	-	-	-	-	-	-
5/8	3/16 x 3/32	X	X	X	-	-	X	-	-	-	-	-	-
21/32	3/16 x 3/32	-	X	X	-	-	-	-	-	-	-	-	-
11/16	3/16 x 3/32	X	X	X	-	-	X	-	-	-	-	-	-
3/4	3/16 x 3/32	X	X	X	X	-	X	X	-	-	-	-	-
25/32	3/16 x 3/32	-	X	X	-	-	-	-	-	-	-	-	-
13/16	3/16 x 3/32	X	X	X	X	-	X	X	-	-	-	-	-
7/8	3/16 x 3/32	X	X	X	X	-	X	X	-	-	-	-	-
15/16	1/4 x 1/8	X*	X	X	X	-	X	X	X	-	-	-	-
31/32	1/4 x 1/8	-	X	X	-	-	-	-	-	-	-	-	-
1	1/4 x 1/8	X*	X	X	X	-	X	X	X	-	-	-	-
1 1/16	1/4 x 1/8	-	X	X	X	-	X	X	X	-	-	-	-
1 1/8	1/4 x 1/8	-	X	X	X	X	X	X	X	-	-	-	-
1 3/16	1/4 x 1/8	-	X	X	X	-	X	X	X	-	-	-	-
1 1/4	1/4 x 1/8	-	X*	X	X	-	X	X	X	-	-	-	-
1 5/16	5/16 x 5/32	-	X*	X	X	-	X	X	X	-	-	-	-
1 3/8▲	5/16 x 5/32	-	X*	X	X	X*	X	X	X	X	X	X	X
1 3/8▲	3/8 x 3/16	-	X*	X	X	-	X	X	X	-	-	-	-
1 7/16	3/8 x 3/16	-	X*	X	X*	-	X	X	X	X	X	X	X
1 1/2	3/8 x 3/16	-	X*	X	X	-	X	X	X	X	X	X	X
1 9/16	3/8 x 3/16	-	-	X	X	-	X	X	X	X	X	X	X
1 5/8	3/8 x 3/16	-	-	X	X	X	X	X	X	X	X	X	X
1 11/16	3/8 x 3/16	-	-	X	X	-	X	X	X	X	X	X	X
1 3/4	3/8 x 3/16	-	-	X	X	-	X	X	X	X	X	X	X
		B	Q1	Q2	Q3	R1	R2	S1	S2	U0	U1	U2	
1 13/16	1/2 x 1/4	X	X	X	X	X	X	-	-	-	-	-	-
1 7/8	1/2 x 1/4	X	X	X	X	X	X	X	X	-	-	-	-
1 15/16	1/2 x 1/4	X	X	X	X	X	X	X	X	-	-	-	-
2	1/2 x 1/4	X	X	X	X	X	X	X	X	-	-	-	-
2 1/16	1/2 x 1/4	X	X	X	X	X	X	X	X	-	-	-	-
2 1/8	1/2 x 1/4	X	X	X	X	X	X	X	X	-	-	-	-
2 3/16	1/2 x 1/4	X	X	X	X	X	X	X	X	-	-	-	-
2 1/4	1/2 x 1/4	X	X	X	X	X	X	X	X	-	-	-	-
2 5/16	5/8 x 5/16	X	X	X	X	X	X	X	X	-	-	-	-
2 3/8	5/8 x 5/16	X	X	X	X	X	X	X	X	X	X	X	X
2 7/16	5/8 x 5/16	X	X	X	X	X	X	X	X	X	X	X	X
2 1/2	5/8 x 5/16	-	X	X	X	X	X	X	X	X	X	X	X
2 9/16	5/8 x 5/16	-	X	X	X	X	X	X	X	X	X	X	X
2 5/8	5/8 x 5/16	-	X	X	-	X	X	X	X	X	X	X	X
2 11/16	5/8 x 5/16	-	X	-	-	X	X	X	X	X	X	X	X
2 3/4	5/8 x 5/16	-	-	-	-	X	X	X	X	X	X	X	X
2 13/16	3/4 x 3/8	-	-	-	-	X	X	-	-	-	-	-	-
2 7/8	3/4 x 3/8	-	-	-	-	X	X	X	X	X	X	X	X
2 15/16	3/4 x 3/8	-	-	-	-	X	X	X	X	X	X	X	X
3	3/4 x 3/8	-	-	-	-	X	X	X	X	X	X	X	X
3 1/8	3/4 x 3/8	-	-	-	-	X	X	X	X	X	X	X	X
3 3/16	3/4 x 3/8	-	-	-	-	X	X	X	X	X	X	X	X
3 1/4	3/4 x 3/8	-	-	-	-	X	X	X	X	X	X	X	X
		R1	R2	S1	S2	U0	U1	U2	W1	W2			
3 3/8	7/8 x 7/16	X	X	X	X	X	X	X	X	X	X	X	X
3 7/16	7/8 x 7/16	X	X	X	X	X	X	X	X	X	X	X	X
3 1/2	7/8 x 7/16	X	X	X	X	X	X	X	X	X	X	X	X
3 5/8	7/8 x 7/16	X	X	X	X	X	X	X	X	X	X	X	X
3 11/16	7/8 x 7/16	X	-	X	X	X	X	X	X	X	X	X	X
3 3/4	7/8 x 7/16	X	-	X	X	X	X	X	X	X	X	X	X
3 7/8	1 x 1/2	-	-	X	X	X	X	X	X	X	X	X	X
3 15/16	1 x 1/2	-	-	X	X	X	X	X	X	X	X	X	X
4	1 x 1/2	-	-	X	X	X	X	X	X	X	X	X	X
4 1/8	1 x 1/2	-	-	X	X	X	X	X	X	X	X	X	X
4 3/26	1 x 1/2	-	-	X	X	X	X	X	X	X	X	X	X
4 1/4	1 x 1/2	-	-	X	X	X	X	X	X	X	X	X	X
4 3/8	1 x 1/2	-	-	X	X	X	X	X	X	X	X	X	X
4 7/16	1 x 1/2	-	-	X	X	X	X	X	X	X	X	X	X
4 1/2	1 x 1/2	-	-	X	X	X	X	X	X	X	X	X	X
4 5/8	1 1/4 x 5/8	-	-	-	-	X	X	X	X	X	X	X	X
4 11/16	1 1/4 x 5/8	-	-	-	-	X	X	X	X	X	X	X	X
4 3/4	1 1/4 x 5/8	-	-	-	-	X	X	X	X	X	X	X	X
4 7/8	1 1/4 x 5/8	-	-	-	-	X	X	X	X	X	X	X	X
4 15/16	1 1/4 x 5/8	-	-	-	-	X	X	X	X	X	X	X	X
5	1 1/4 x 5/8	-	-	-	-	X	X	X	X	X	X	X	X
		U0	U1	W1	W2								
5 1/8	1 1/4 x 5/8	X	X	X	X								
5 3/16	1 1/4 x 5/8	X	X	X	X								
5 1/4	1 1/4 x 5/8	X	X	X	X								
5 3/8	1 1/4 x 5/8	X	X	X	X								
5 7/16	1 1/4 x 5/8	X	X	X	X								
5 1/2	1 1/4 x 5/8	X	X	X	X								

▲ 1 3/8 Bore Bushings with 5/16" x 5/32" keyway will be shipped unless the 3/8 x 3/16 keyway is specified on the order.  
\* These sizes have a shallow keyseat. Special keys are furnished to fit standard depth keyseats in shafts.

**Table No.1 (Cont'd.)**

Stock Bore	Keyseat	W1	W2
5 5/8	1 1/2 x 3/4	X	X
5 3/4	1 1/2 x 3/4	X	X
5 7/8	1 1/2 x 3/4	X	X
5 15/16	1 1/2 x 3/4	X	X
6	1 1/2 x 3/4	X	X
6 1/8	1 1/2 x 3/4	X	X
6 3/16	1 1/2 x 3/4	X	X
6 1/4	1 1/2 x 3/4	X	X
6 3/8	1 1/2 x 3/4	X	X
6 7/16	1 1/2 x 3/4	X	X
6 1/2	1 1/2 x 3/4	X	X
6 5/8	1 3/4 x 3/4	X	X
6 3/4	1 3/4 x 3/4	X	X
6 7/8	1 3/4 x 3/4	X	X
6 15/16	1 3/4 x 3/4	X	X
7	1 3/4 x 3/4	X	X
7 1/8	1 3/4 x 3/4	X	X
7 3/16	1 3/4 x 3/4	X	X
7 1/4	1 3/4 x 3/4	X	X
7 3/8	1 3/4 x 3/4	X	X
7 7/16	1 3/4 x 3/4	X	X

**Table No.2 Stock Millimeter Bore Bushings**

Stock Bore	Keyseat (Millimeters)	G	H	P1	B	Q1	R1	R2
10 mm.	None	X	X	-	-	-	-	-
11 mm.	None	X	X	-	-	-	-	-
12 mm.	None	X	X	-	-	-	-	-
14 mm.	5 x 25	X	X	X	-	-	-	-
15 mm.	5 x 25	-	-	X	X	-	-	-
16 mm.	5 x 25	X	X	X	X	-	-	-
18 mm.	6 x 3	X	X	X	X	-	-	-
19 mm.	6 x 3	X	X	X	X	X	-	-
20 mm.	6 x 3	X	X	X	X	X	-	-
22 mm.	6 x 3	X	X	X	X	X	-	-
24 mm.	8 x 3.5	X	X	X	X	X	-	-
25 mm.	8 x 3.5	X	X	X	X	X	-	-
28 mm.	8 x 3.5	-	X	X	X	X	X	-
30 mm.	8 x 3.5	-	X	X	X	X	X	-
32 mm.	10 x 4	-	X	X	X	X	X	-
35 mm.	10 x 4	-	X	X	X	X	X	X
36 mm.	10 x 4	-	X	X	X	X	X	X
38 mm.	10 x 4	-	X	X	X	X	X	X
39 mm.	12 x 4	-	-	X	X	X	X	X
40 mm.	12 x 4	-	-	X	X	X	X	X
42 mm.	12 x 4	-	-	X	X	X	X	X
45 mm.	14 x 4.5	-	-	-	X	X	X	X
48 mm.	14 x 4.5	-	-	-	X	X	X	X
50 mm.	14 x 4.5	-	-	-	X	X	X	X
55 mm.	16 x 5	-	-	-	X	X	X	X
60 mm.	18 x 5.5	-	-	-	X	X	X	X
65 mm.	18 x 5.5	-	-	-	-	X	X	X
70 mm.	20 x 6	-	-	-	-	-	X	X
75 mm.	20 x 6	-	-	-	-	-	-	X
80 mm.	22 x 7	-	-	-	-	-	-	X
85 mm.	22 x 7	-	-	-	-	-	-	X
90 mm.	25 x 7	-	-	-	-	-	-	X
95 mm.	25 x 7	-	-	-	-	-	-	X

**Table No.3 Stock Spline Bore Bushings**

Spline	H	P1	Q1	Q2
.978 - 10 Inv.	x	x	-	-
1 1/8 - 6B	x	x	x	-
1 1/4 - 10B	-	x	-	-
1 3/8 - 6B	x	x	x	x
1 3/8 - 10B	-	x	x	-
1 3/8 - 21Inv.	x	x	x	-

# JA 1/2 - P 7

## Q-D® BUSHINGS

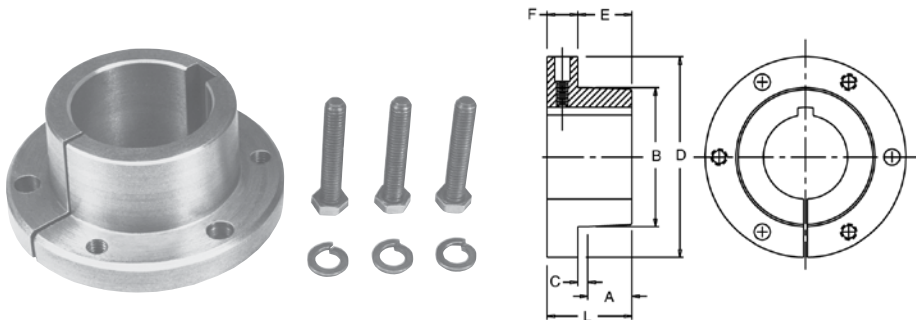

**Table No.2 - Flange Set Screw**

	Thread	Tightening Torque (in-lb)
SH, SDS, SD, SK	1/4 - 20	87
SF	5/16 - 18	165
E, F, J, M	3/8 - 16	290
N	7/8 - 9	5000

**Table No.1 Bushing Specifications**

Bushing	Bore Range (in.)	Dimensions (in.)							Cap Screws			Torque Capacity In.-Lbs.	Wrench Torque Ft.-Lbs.	Average Weight Lbs.
		D	L	A	B	C	E	F	No.	Size	Bolt Circle			
JA	1/2 - 1 1/4	2	7/8	11/32	1 3/8	3/16	9/16	5/16	3	10 - 24 x 1	1 21/32	1000	6	0,8
SH	1/2 - 1 5/8	2 11/16	1 1/4	9/16	1 7/8	1/4	13/16	7/16	3	1/4-20 x 1 3/8	2 1/4	3500	9	1
SDS	1/2 - 2	3 1/8	1 5/16	9/16	2 3/16	1/4	7/8	7/16	3	1/4-20 x 1 3/8	2 11/16	5000	9	1,2
SD	1/2 - 2	3 1/8	1 13/16	1 1/8	2 3/16	1/4	1 3/8	7/16	3	1/4-20 x 1 7/8	2 11/16	5000	9	1,5
SK	1/2 - 2 5/8	3 7/8	3/4	13/16	2 13/16	3/8	1 3/16	9/16	3	5/16-18 x 2	3 5/16	7000	15	2
SF	1/2 - 2 15/16	4 5/8	2	1 1/8	3 1/8	3/8	1 7/16	9/16	3	3/8-16 x 2	3 7/8	11000	30	3,5
E	7/8 - 3 1/2	6	2 51/80	1 9/16	3 13/16	3/8	1 7/8	3/4	3	1/2-13 x 2 3/4	5	20000	60	9
F	1 - 4	6 5/8	2 11/16	2 5/16	4 7/16	7/16	2 3/4	15/16	3	9/16-12 x 3 5/8	5 5/8	30000	75	14
J	1 1/2 - 4 1/2	7 1/4	4 1/2	3 1/16	5 3/16	7/16	3 1/2	1	3	5/8-11 x 4 1/2	6 1/4	45000	135	22
M	2 - 5 1/2	9	6 3/4	5 1/16	6 1/2	7/16	5 1/2	1 1/4	4	3/4-10 x 6 3/4	7 7/8	85000	225	51
N	2 7/16 - 5 7/8	10	8 11/80	6 3/16	7	7/16	6 5/8	1 1/2	4	7/8-9 x 8	8 1/2	150000	300	66
P	2 15/16 - 7	11 3/4	9 31/80	7 3/16	8 1/4	7/16	7 5/8	1 3/4	4	1-8 x 9 1/2	10	250000	450	122

Note: All Bushings shown except JA have setscrew over keyway.



### Bushing Flange Toward Machine or Motor

1. Align tapped holes in bushing flange with drilled holes in sheave hub.
2. Insert cap screws through drilled holes in sheave hub and thread loosely into tapped holes in bushing flange.
3. Position assembly on shaft and tighten cap screws progressively and uniformly.

### To Remove

1. Remove cap screws and thread into tapped holes in sheave hub. Tighten progressively until bushing is free from sheave taper.
2. Remove assembly from shaft.

### Bushing Flange Away From Machine or Motor

1. Align drilled holes in bushing flange with tapped holes in sheave hub.
2. Insert cap screws through drilled holes in bushing flange and thread loosely into tapped holes in sheave hub.
3. Position assembly on shaft and tighten cap screws progressively and uniformly.

### To Remove

1. Remove capscrews and thread into tapped holes in bushing flange. Tighten progressively until bushing is free from sheave taper.
2. Remove assembly from shaft.

**Cap screws are always accessible from the outside.**

## Q-D® BUSHINGS

**Table No.1 Stock Inch Bore Bushings**

Stock Bores	Keyseat	JA	SH	SDS	SD	SK	SF	E	F	J
1/2	1/8 x 1/16	X	X	X	X	X	X	-	-	-
9/16	1/8 x 1/16	X	X	X	X	X	X	-	-	-
5/8	3/16 x 3/32	X	X	X	X	X	X	-	-	-
1/16	3/16 x 3/32	X	X	X	X	X	X	-	-	-
3/4	3/16 x 3/32	X	X	X	X	X	X	-	-	-
13/16	3/16 x 3/32	X	X	X	X	X	X	-	-	-
7/8	3/16 x 3/32	X	X	X	X	X	X	X	-	-
15/16	1/4 x 1/8	X	X	X	X	X	X	X	-	-
1	1/4 x 1/8	X	X	X	X	X	X	X	X	-
1 1/16	1/4 x 1/8	S	X	X	X	X	X	X	X	-
1 1/8	1/4 x 1/8	S	X	X	X	X	X	X	X	-
1 3/16	1/4 x 1/8	S	X	X	X	X	X	X	X	-
1 1/4	1/4 x 1/8	-	X	X	X	X	X	X	X	-
1 5/16	5/16 x 5/32	-	X	X	X	X	X	X	X	-
1 5/16*	3/8 x 3/16	-	X	X	X	X	X	X	X	-
1 3/8	5/16 x 5/32	-	X	X	X	X	X	X	X	-
1 3/8*	3/8 x 3/16	-	X	X	X	X	X	X	X	-
1 7/16	3/8 x 3/16	-	S	X	X	X	X	X	X	-
1 1/12	3/8 x 3/16	-	S	X	X	X	X	X	X	X
1 9/16	3/8 x 3/16	-	S	X	X	X	X	X	X	X
1 5/8	3/8 x 3/16	-	S	X	X	X	X	X	X	X
1 11/16	3/8 x 3/16	-	S	X	X	X	X	X	X	X
		<b>SDS</b>	<b>SD</b>	<b>SK</b>	<b>SF</b>	<b>E</b>	<b>F</b>	<b>J</b>	<b>M</b>	<b>N</b>
1 3/4	3/8 x 3/16	S	S	X	X	X	X	X	-	-
1 13/16	1/2 x 1/4	S	S	X	X	X	X	X	-	-
1 7/8	1/2 x 1/4	S	S	X	X	X	X	X	-	-
1 15/16	1/2 x 1/4	S	S	X	X	X	X	X	-	-
2	1/2 x 1/4	N	N	X	X	X	X	X	X	-
2 1/16	1/2 x 1/4	-	-	X	X	X	X	X	X	-
2 1/8	1/2 x 1/4	-	-	X	X	X	X	X	X	-
2 3/16	1/2 x 1/4	-	-	S	X	X	X	X	X	-
2 1/4	1/2 x 1/4	-	-	S	X	X	X	X	X	-
2 5/16	5/8 x 5/16	-	-	S	X	X	X	X	X	-
2 3/8	5/8 x 5/16	-	-	S	X	X	X	X	X	-
2 7/16	5/8 x 5/16	-	-	S	X	X	X	X	X	X
2 1/2	5/8 x 5/16	-	-	S	X	X	X	X	X	X
2 9/16	5/8 x 5/16	-	-	N	S	X	X	X	X	X
2 5/8	5/8 x 5/16	-	-	N	S	X	X	X	X	X
		<b>SF</b>	<b>E</b>	<b>F</b>	<b>J</b>	<b>M</b>	<b>N</b>	<b>P</b>		
2 11/16	5/8 x 5/16	S	X	X	X	X	X	-	-	-
2 3/4	5/8 x 5/16	S	X	X	X	X	X	-	-	-
2 13/16	3/4 x 3/8	S	X	X	X	X	X	-	-	-
2 7/8	3/4 x 3/8	S	X	X	X	X	X	-	-	-
2 15/16	3/4 x 3/8	S	X	X	X	X	X	X	-	-
3	3/4 x 3/8	-	S	X	X	X	X	X	-	-
3 1/16	3/4 x 3/8	-	S	X	X	X	X	X	-	-
3 1/8	3/4 x 3/8	-	S	X	X	X	X	X	-	-
3 3/16	3/4 x 3/8	-	S	X	X	X	X	X	-	-
3 1/4	3/4 x 3/8	-	S	X	X	X	X	X	-	-
3 5/16	7/8 x 7/16	-	S	S	X	X	X	X	-	-
3 3/8	7/8 x 7/16	-	S	S	X	X	X	X	-	-
3 7/16	7/8 x 7/16	-	S	S	X	X	X	X	-	-
3 1/2	7/8 x 7/16	-	S	S	X	X	X	X	-	-
3 9/16	7/8 x 7/16	-	-	S	X	X	X	X	-	-
3 5/8	7/8 x 7/16	-	-	S	X	X	X	X	-	-
3 11/16	7/8 x 7/16	-	-	S	X	X	X	X	-	-
3 3/4	7/8 x 7/16	-	-	S	X	X	X	X	-	-
3 13/16	7/8 x 7/16	-	-	S	X	X	X	X	-	-
3 7/8	1 x 1/2	-	-	S	S	X	X	X	-	-
3 15/16	1 x 1/2	-	-	S	S	X	X	X	-	-
4	1 x 1/2	-	-	N	S	X	X	X	-	-
		<b>J</b>	<b>M</b>	<b>N</b>	<b>P</b>					
4 1/16	1 x 1/2	S	X	X	X	-	-	-	-	-
4 1/8	1 x 1/2	S	X	X	X	-	-	-	-	-
4 3/16	1 x 1/2	S	X	X	X	-	-	-	-	-
4 1/4	1 x 1/2	S	X	X	X	-	-	-	-	-
4 5/16	1 x 1/2	S	X	X	X	-	-	-	-	-
4 3/8	1 x 1/2	S	X	X	X	-	-	-	-	-
4 7/16	1 x 1/2	S	X	X	X	-	-	-	-	-
4 1/2	1 x 1/2	S	X	X	X	-	-	-	-	-
4 9/16	1 1/4 x 5/8	S	X	X	X	-	-	-	-	-
4 5/8	1 1/4 x 5/8	S	X	X	X	-	-	-	-	-
4 11/16	1 1/4 x 5/8	-	X	X	X	-	-	-	-	-
4 3/4	1 1/4 x 5/8	-	X	X	X	-	-	-	-	-
4 13/16	1 1/4 x 5/8	-	S	X	X	-	-	-	-	-
4 7/8	1 1/4 x 5/8	-	S	X	X	-	-	-	-	-
4 15/16	1 1/4 x 5/8	-	S	X	X	-	-	-	-	-
5	1 1/4 x 5/8	-	S	X	X	-	-	-	-	-
5 1/16	1 1/4 x 5/8	-	S	X	X	-	-	-	-	-
5 1/8	1 1/4 x 5/8	-	S	S	X	-	-	-	-	-
5 3/16	1 1/4 x 5/8	-	S	S	X	-	-	-	-	-
5 1/4	1 1/4 x 5/8	-	S	S	X	-	-	-	-	-
5 5/16	1 1/4 x 5/8	-	S	S	X	-	-	-	-	-
5 3/8	1 1/4 x 5/8	-	S	S	X	-	-	-	-	-
5 7/16	1 1/4 x 5/8	-	S	S	X	-	-	-	-	-
5 1/2	1 1/4 x 5/8	-	S	S	X	-	-	-	-	-

**Table No.1 (Cont'd.)**

Stock Bores	Keyseat	N	P
5 9/16	1 1/2 x 3/4	S	X
5 5/8	1 1/2 x 3/4	S	X
5 11/16	1 1/2 x 3/4	S	X
5 3/4	1 1/2 x 3/4	S	X
5 13/16	1 1/2 x 3/4	S	X
5 7/8	1 1/2 x 3/4	S	S
5 15/16	1 1/2 x 3/4	-	S
6	1 1/2 x 3/4	-	S
6 1/16	1 1/2 x 3/4	-	S
6 1/8	1 1/2 x 3/4	-	S
6 3/16	1 1/2 x 3/4	-	S
6 1/4	1 1/2 x 3/4	-	S
6 5/16	1 1/2 x 3/4	-	S
6 3/8	1 1/2 x 3/4	-	S
6 7/16	1 1/2 x 3/4	-	S
6 1/2	1 1/2 x 3/4	-	S
6 9/16	1 3/4 x 3/4	-	S
6 5/8	1 3/4 x 3/4	-	S
6 11/16	1 3/4 x 3/4	-	S
6 3/4	1 3/4 x 3/4	-	S
6 13/16	1 3/4 x 3/4	-	S
6 7/8	1 3/4 x 3/4	-	S
6 15/16	1 3/4 x 3/4	-	S
7	1 3/4 x 3/4	-	S

**Table No.2 Stock Millimeter Bore Bushings**

Stock Bores	Keyseat (Millimeters)	SH	SDS	SD	SK	SF	E	F	J
24	8 x 3.5	X	X	X	X	-	-	-	-
25	8 x 3.5	X	X	X	X	-	-	-	-
28	8 x 3.5	X	X	X	X	X	-	-	-
30	8 x 3.5	X	X	X	X	X	-	-	-
32	10 x 4	X	X	X	X	X	-	-	-
35	10 x 4	X	X	X	X	X	-	-	-
38	10 x 4	-	X	X	X	X	X	-	-
40	12 x 4	-	X	X	X	X	X	-	-
42	12 x 4	-	X	X	X	X	X	-	-
45	14 x 4.5	-	-	-	-	X	X	X	-
48	14 x 4.5	-	X	-	X	X	X	X	-
50	14 x 4.5	-	-	-	X	X	X	X	X
55	16 x 5	-	-	-	X	X	X	X	X
60	18 x 5.5	-	-	-	-	X	X	X	X
65	18 x 5.5	-	-	-	-	X	X	X	X
70	20 x 6	-	-	-	-	X	X	X	X
75	20 x 6	-	-	-	-	X	X	X	X
80	22 x 7	-	-	-	-	-	-	X	X
85	22 x 7	-	-	-	-	-	-	X	X
90	25 x 7	-	-	-	-	-	-	X	X
95	25 x 7	-	-	-	-	-	-	-	X
100	28 x 8	-	-	-	-	-	-	-	X

\* Bushings with 5/16" x 5/32" keyway will be shipped unless the 3/8 x 3/16 keyway is specified on the order.

X = Stock bore with standard keyway.

N = Stock bore with no keyway.

S = Stock bore with shallow keyway; rectangular key is furnished to fit standard keyseat.

# HG1 - HW1

## WELDABLE STEEL HUBS

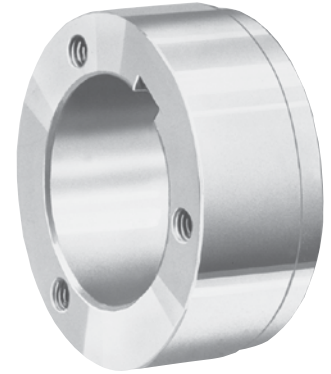
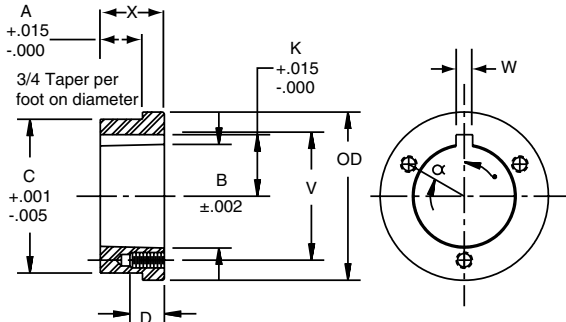

**Table No.1 Steel Hubs for Browning® Split Taper® Bushings**

Part No.	For Bushing	Dimensions (in.)									Tapped Holes			Wt. Lbs.
		O.D.	A	B	C	K	V	W	X	a	d	No.	Size	
HG1	G	2	0.174	1.168	1.875	-	1 9/16	-	5.8	-	5.8	2	1/4 - 20	0.4
HH1	H	2 1/2	0.174	1.621	2.375	-	2	-	7/8	-	7/8	2	1/4 - 20	0.6
HCH1	H	2 1/2	0.625	1.621	2.375	-	2	-	7/8	-	7/8	2	1/4 - 20	0.7
HP1	P1	3	0.292	1.9375	2.875	1 3/32	2 7/16	3/8	1 5/16	60°	5/8	3	5/16 - 18	1.4
HCP1	P1	3	1	1.9375	2.875	1 3/32	2 7/16	3/8	1 5/16	60°	5/8	3	5/16 - 18	1.1
HP2	P2	3	1.1	1.9375	2.875	1 3/32	2 7/16	3/8	2 5/16	60°	5/8	3	5/16 - 18	2.5
HB1	B	3 7/8	0.292	2.623	3.75	1 7/16	3 1/8	1/2	1 5/16	60°	13/16	3	5/16 - 18	2.3
HB2	B	4 1/2	0.709	2.623	4.375	1 7/16	3 1/8	1/2	1 3/4	60°	13/16	3	5/16 - 18	4.7
HQ1	Q1	4 1/2	0.709	2.875	4.375	1 9/16	3 3/8	1/2	1 3/4	60°	7/8	3	3/8 - 16	4.4
HCO1	Q1	4 1/2	1.25	2.875	4.375	1 9/16	3 3/8	1/2	1 3/4	60°	7/8	3	3/8 - 16	4.4
HQ2	Q2	4 1/2	1.606	2.875	4.375	1 9/16	3 3/8	1/2	2 3/4	60°	7/8	3	3/8 - 16	6.9
HR1	R1	5 3/4	0.709	4	5.625	2 3/16	4 5/8	3/4	2	60°	1 1/8	3	3/8 - 16	7.3
HR2	R2	5 3/4	1.606	4	5.625	2 3/16	4 5/8	3/4	4	60°	1 1/8	3	3/8 - 16	15.4
HS1	S1	6 3/4	0.946	4.625	6.5	2 9/16	5 3/8	3/4	3 5/16	60°	1 5/8	3	1/2 - 13	17.3
HS2	S2	6 3/4	2.963	4.625	6.5	2 9/16	5 3/8	3/4	5 11/16	60°	1 5/8	3	1/2 - 13	30.4
HU0	U0	8 1/2	2	6	8.25	3 1/4	7	1 1/4	3 3/4	60°	2	3	5/8 - 11	32
HU1	U1	8 1/2	2.963	6	8.25	3 1/4	7	1 1/4	5 5/8	60°	1 3/4	3	5/8 - 11	44.6
HU2	U2	8 1/2	6.016	6	8.25	3 1/4	7	1 1/4	8 5/8	60°	1 3/4	3	5/8 - 11	69
HW1	W1	12 1/2	2.963	8.5	12.25	4 9/16	10	1 1/4	6 3/8	22 1/2°	1 3/4	4	3/4 - 10	130

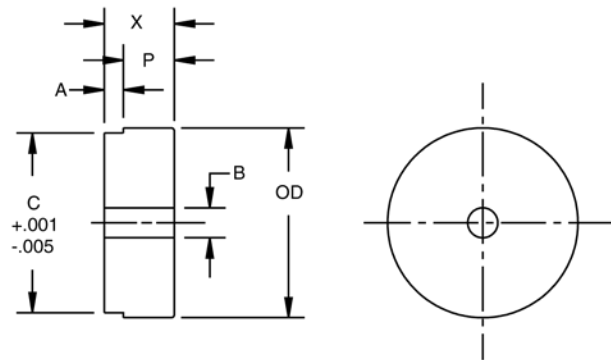

**Table No.2 Type "B" Steel Hubs**

Part No.	Dimensions					Bore		Wt. Lbs.
	O.D.	A	C	P	X	Stock	Max.	
HB40	3	0.281	2.875	27/32	1 1/8	1/2	1 7/8	2.3
HB50	3 1/4	0.344	3.125	1 1/32	1 3/8	5/8	2 1/4	3
HB60	4	0.469	3.875	1 1/32	1 1/2	5/8	2 3/8	5
HB80	5	0.563	4.875	1 1/2	2	3/4	3	11.1
HB100	5 1/4	0.688	5.125	2 1/16	2 3/4	1	3 1/4	16.3

Note: "A" dimension is plate thickness of sprocket for chain indicated in part number. Other plates can be used by remachining "A" dimension.

# Browning®

## Bearings...

### **MOUNTED BALL BEARINGS**

- Air handling housing fits available from stock
- Semi-solid cast iron base
- Anti-rotation rivet

### **STAMPED STEEL/RUBBER MOUNTED**

- Designed to fit into HVAC web-mount supports



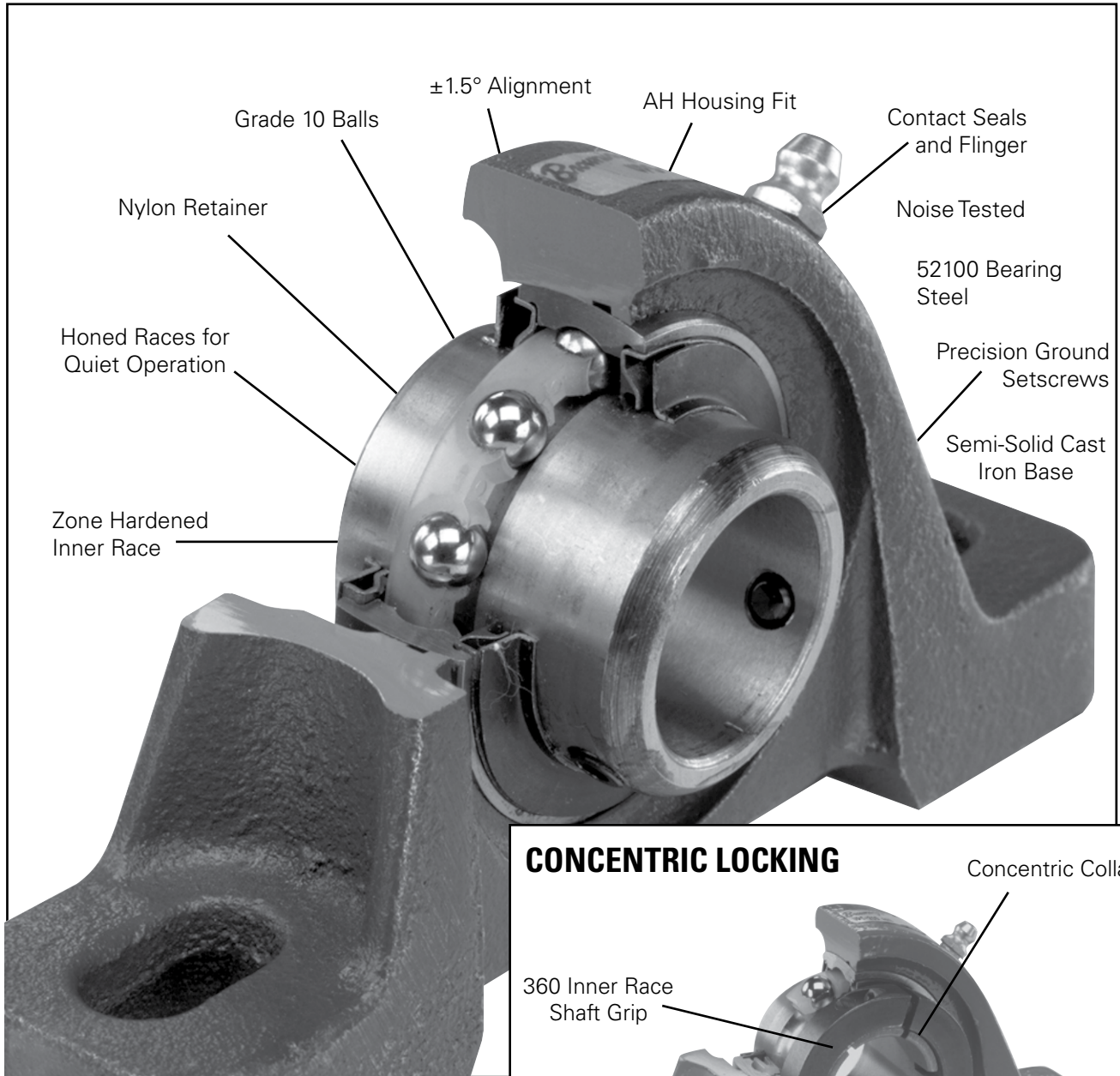

## CONCENTRIC LOCKING

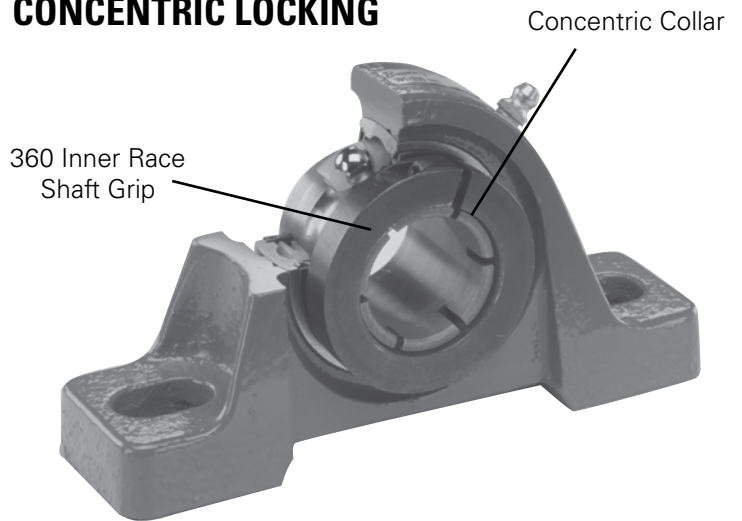

**Reduced Vibration and Quieter Operation**

## **BROWNING® AH AIR HANDLING BALL BEARINGS FEATURES/BENEFITS**

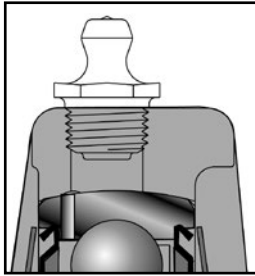

## AH HOUSING FIT

Air handling AH ball bearings are manufactured with a special AH housing fit that allows the bearing to more easily self-align when mounted on light-weight frames.



## PRECISION HARDENED AND HONED RINGS

Inner rings are zone hardened to maintain ballpath hardness while keeping inner ring extension soft for a precision setscrew hold. Both ballpaths are honed for quieter operation and less vibration.

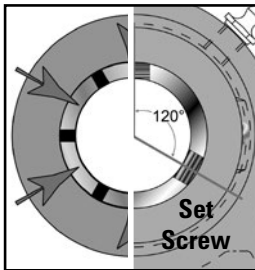

## SUPERIOR LOCKING

Browning superior locking devices perform well with air handlers. The 120° setscrew positioning with a zone hardened inner race offers excellent reliability. The concentric locking collar reduces noise and vibration.

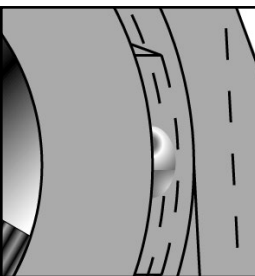

## ANTI-ROTATION RIVET

An anti-rotation rivet prevents outer ring creep or rotation within the housing. This reduces heat buildup and prolongs useful bearing life.

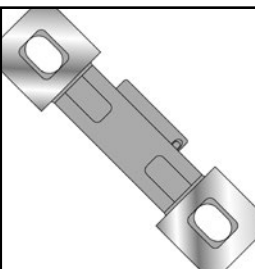

## SEMI-SOLID CAST IRON BASE

The rugged base design provides an excellent mounting foundation. This is integral to prevent sheet metal "buckling."

## NOISE TESTED

An extra noise test check point is added to meet the exacting noise level needs of the air handling industry.

# BROWNING® AH AIR HANDLING BALL BEARINGS

## FEATURES/BENEFITS

### SERIES

Popular shaft sizes and housing configurations in the normal and medium duty series are available "off-the-shelf" with air handling features (designated by the AH suffix). These products are offered with both setscrew style locking and the increasingly popular concentric 360° locking collar. AH bearings are segmented into two series: Normal duty for general purpose use and medium duty for heavier loads.

### PRODUCT OVERVIEW

Browning products move air! Browning bearing products have long been specified by the nation's leading OEMs of HVAC and air handling equipment. From agricultural fans up to blast restaurant exhaust ventilators to unitary rooftop systems to rugged material handling and cooling tower applications Browning bearings have proven reliable to economically meet customer needs.

Specially designed Browning "AH" Air Handling Bearings are available as stock products "off-the-shelf"! The "AH" suffix designation means mounted bearings with a specially controlled "bearing-to-housing fit" and 100% noise tested utilizing state-of-the-art andrometer equipment.

To specify add "AH" i.e. VPS-216 AH

## VPS-200AH

**Lock:** Setscrew  
**Seal:** Contact  
**Housing:** Cast Iron  
**Temperature:** -20° F to 200° F  
**Self Alignment:** ±1.5°  
**Inserts:** VS-200

**V VALUE and QUALITY**  
**P PILLOW BLOCK**  
**S Setscrew**

**2 200**  
**0 NORMAL**  
**0 DUTY**  
**A AIR**  
**H HANDLING**

Bore Size (in.)	Fitting (in.)
1/2 - 1 1/4 S	1/4 - 28NF
1 1/4 - 2 7/16	1/8 NPT

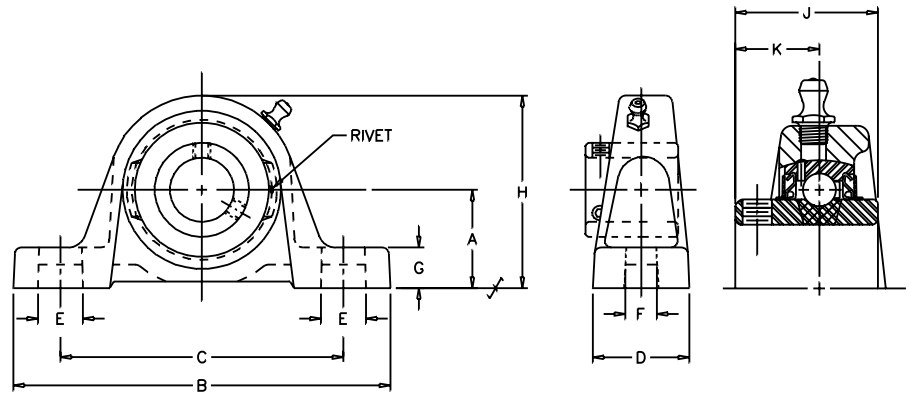

SHAFT DIA. (in.)	UNIT NO.	BRG. NO.	Dimensions (in.)										BOLT SIZE (in.)	UNIT WT.
			A	B	C	D	E	F	G	H	J	K		
1/2 5/8	VPS-208AH VPS-210AH	VS-208 VS-210	1 3/16	4 7/8	3 5/8	1 7/32	7/8	7/16	15/32	2 7/32	1 1/32	5/8	3/8	.9
3/4	VPS-212AH	VS-212	1 5/16	5	3 25/32	1 11/32	25/32	7/16	17/32	2 17/32	1 7/32	23/32	3/8	1.4
7/8 15/16 1	VPS-214AH VPS-215AH VPS-216AH	VS-214 VS-215 VS-216	1 7/16	5 1/2	4 1/8	1 13/32	13/16	7/16	19/32	2 13/16	1 3/8	13/16	3/8	1.5
1 1/8 1 3/16 1 1/4	VPS-218AH VPS-219AH VPS-220SAH	VS-218 VS-219 VS-220S	1 11/16	6 3/16	4 5/8	1 3/4	15/16	9/16	21/32	3 9/32	1 1/2	7/8	1/2	2.5
1 1/4 1 3/8 1 7/16	VPS-220AH VPS-222AH VPS-223AH	VS-220 VS-222 VS-223	1 7/8	6 3/4	5	1 3/4	7/8	9/16	23/32	3 11/16	1 11/16	1	1/2	3.5
1 1/2	VPS-224AH	VS-224	2	7 1/8	5 3/8	1 15/16	1	9/16	13/16	4	1 15/16	1 3/16	1/2	4.7
1 5/8 1 11/16 1 3/4	VPS-226AH VPS-227AH VPS-228AH	VS-226 VS-227 VS-228	2/18	7 3/8	5 21/32	2	29/32	9/16	3/4	4 1/4	1 15/16	1 3/16	1/2	5.5
1 15/16 2	VPS-231AH VPS-232SAH	VS-231 VS-232S	2 1/4	8	6 3/16	2 3/16	15/16	11/16	3/4	4 9/16	2 1/32	1 9/32	5/8	6.0
2 2 3/16	VPS-232AH VPS-235AH	VS-232 VS-235	2 1/2	8 13/16	6 15/16	2 5/16	1	11/16	7/8	4 31/32	2 3 1/6	1 5/16	5/8	7.8
2 1/4 2 7/16	VPS-236AH VPS-239AH	VS-236 VS-239	2 3/4	9 1/2	7 13/32	2 3/8	1 5/32	11/16	7/8	5 9/16	2 9/16	1 9/16	5/8	10.1

For the most up-to-date bearing cross reference information go to [www.regalrexnord.com](http://www.regalrexnord.com) or call Application Engineering at 1-800-626-2093.

**VALUE and QUALITY V**  
**PILLOW BLOCK P**  
**LOW BASE L**  
**Setscrew S**  
  
**200 2**  
**NORMAL 0**  
**DUTY 0**  
**AIR A**  
**HANDLING H**

## VPLS-200AH

**Lock:** Setscrew  
**Seal:** Contact  
**Housing:** Cast Iron  
**Temperature:** -20° F to 200° F  
**Self Alignment:** ±1.5°  
**Inserts:** VS-200

Bore Size (in.)	Fitting (in.)
1/2 - 1 1/4 S	1/4 - 28NF
1 1/4 - 2 15/16	1/8 NPT

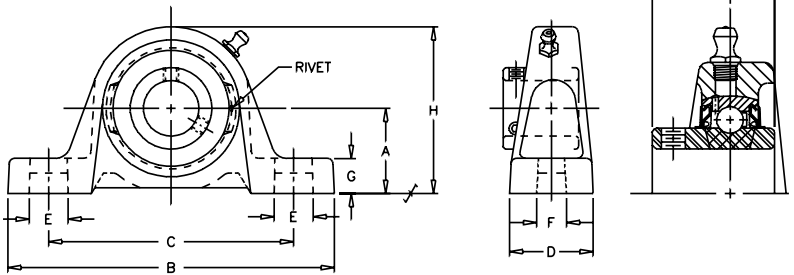

SHAFT DIA. (in.)	UNIT NO.	BRG. NO.	Dimensions (in.)										BOLT SIZE (in.)	UNIT WT.
			A	B	C	D	E	F	G	H	J	K		
3/4	VPLS-212AH	VS-212	1 1/4	5	3 25/32	1 11/32	25/32	7/16	15/32	2 15/32	1 7/32	1/2	3/8	1.3
1	VPLS-216AH	VS-216	1 5/16	5 1/2	4 1/8	1 13/32	13/16	7/16	15/32	2 11/16	1 3/8	9 1/6	3/8	1.4
1 3/16 1 1/4	VPLS-219AH VPLS-220SAH	VS-219 VS-220S	1 9/16	6 3/16	4 5/8	1 3/4	15/16	9/16	17/32	3 5/32	1 1/2	5/8	1/2	2.4
1 1/4 1 7/16	VPLS-220AH VPLS-223AH	VS-220 VS-223	1 13/16	6 3/4	5	1 3/4	7/8	9/16	21/32	3 5/8	1 11/16	11/16	1/2	3.5
1 1/2	VPLS-224AH	VS-224	1 15/16	7 1/8	5 3/8	1 15/16	1	9/16	3/4	3 15/16	1 15/16	3/4	1/2	4.5
1 11/16	VPLS-227AH	VS-227	2 1/16	7 3/8	5 21/32	2	29/32	9/16	11/16	4 3/16	1 15/16	3/4	1/2	5.5
1 15/16 2	VPLS-231AH VPLS-232SAH	VS-231	2 3/16	8	6 3/16	2 3/16	15/16	11/16	11/16	4 1/2	2 1/32	3/4	5/8	5.9
2 2 3/16	VPLS-232AH VPLS-235AH	VS-232 VS-235	2 7/16	8 13/16	6 15/16	2 5/16	1	11/16	13/16	4 29/32	2 3/16	7/8	5/8	7.6
2 7/16	VPLS-239AH	VS-239	2 11/16	9 1/2	7 13/32	2 3/8	1 5/32	11/16	13/16	5 1/2	2 9/16	1	5/8	9.7

For the most up-to-date bearing cross reference information go to [www.regalrexnord.com](http://www.regalrexnord.com) or call Application Engineering at 1-800-626-2093.

## VF2S-200AH

**Lock:** Setscrew  
**Seal:** Contact  
**Housing:** Cast Iron  
**Temperature:** -20° F to 200° F  
**Self Alignment:** ±1.5°  
**Inserts:** VS-200

**V VALUE and QUALITY**  
**F FLANGE**  
**2 TWO BOLT**  
**S Setscrew**  
  
**2 200**  
**0 NORMAL**  
**0 DUTY**  
**A AIR**  
**H HANDLING**

Bore Size (in.)	Fitting (in.)
1/2- 1 1/4 S	1/4 - 28NF
1 1/4 - 2 3/16 S	1/8 NPT

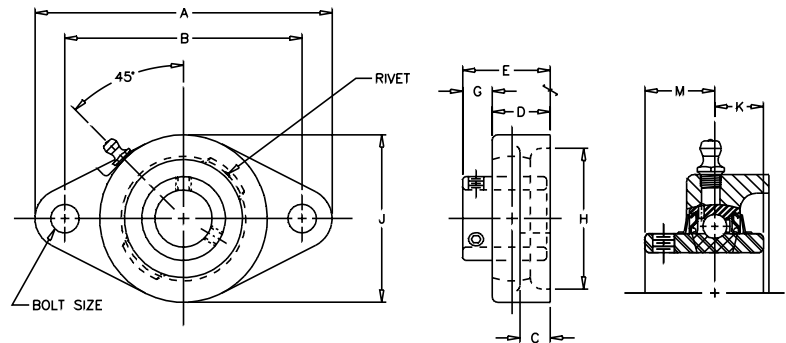

SHAFT DIA. (in.)	UNIT NO.	BRG. NO.	Dimensions (in.)										BOLT SIZE (in.)	UNIT WT.
			A	B	C	D	E	G	H CORED	J	K	M		
3/4	VF2S-212AH	VS-212	4 13/32	3 17/32	7 1/6	57/64	1 9/32	25/64	2	2 1/2	1/2	22/32	3/8	1.0
15/16 1	VF2S-215AH	VS-215	4 7/8	3 57/64	1/2	61/64	1 7/16	31/64	2 5/16	2 3/4	9/16	13/16	7/16	1.1
	VF2S-216AH	VS-216												
13/16 1 1/4	VF2S-219AH	VS-219	5 9/16	4 19/32	17/32	1 5/64	1 9/16	31/64	2 3/4	3 1/8	5/8	7/8	7/16	1.7
	VF2S-220SAH	VS-220S												
1 1/4 1 7/16	VF2S-220AH	VS-220S	6 1/8	5 1/8	19/32	1 5/32	1 3/4	19/32	3 3/16	3 5/8	11/16	1	1/2	2.7
	VF2S-223AH	VS-223												
1 1/2	VF2S-224AH	VS-224	6 3/4	5 21/32	5/8	1 19/64	2 1/64	23/32	3 1/2	4 1/8	3/4	1 3/16	1/2	3.6
1 11/16 1 3/4	VF2S-227AH	VS-227	7 1/16	5 27/32	5/8	1 21/64	2 3/64	23/32	3 3/4	4 3/8	3/4	1 3/16	9/16	3.7
	VF2S-228AH	VS-228												
1 15/16	VF2S-231AH	VS-231	7 1/6	6 3/16	5/8	2 5/32	1 23/64	51/64	4	4 9/16	3/4	1 9/32	9/16	4.6
2 3/16	VF2S-235AH	VS-235	8 1/2	7 1/4	13/16	2 5/16	1 33/64	51/64	4 1/4	5 1/4	7/8	1 5/16	5/8	5.9

For the most up-to-date bearing cross reference information go to [www.regalrexnord.com](http://www.regalrexnord.com) or call Application Engineering at 1-800-626-2093.

VALUE & QUALITY V  
 FLANGE F  
 FOUR BOLT 4  
 Setscrew S  
  
 200 2  
 NORMAL 0  
 DUTY 0  
 AIR A  
 HANDLING H

## VF4S-200AH

Lock: Setscrew  
 Seal: Contact  
 Housing: Cast Iron  
 Temperature: -20° F to 200° F  
 Self Alignment: ±1.5°  
 Inserts: VS-200

Bore Size (in.)	Fitting (in.)
1/2 - 1 1/4 S	1/4 - 28NF
1 1/4 - 2 15/16 S	1/8" NPT

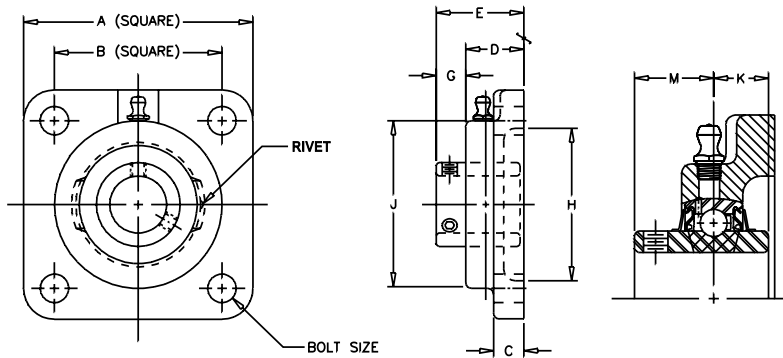

SHAFT DIA. (in.)	UNIT NO.	BRG. NO.	Dimensions (in.)										BOLT SIZE (in.)	UNIT WT.
			A	B	C	D	E	G	H CORED	J	K	M		
1/2 5/8	VF4S-208AH VF4S-210AH	VS-208 VS-210	3	2 1/8	3/8	23/32	1 5/64	23/64	1 3/4	2 1/8	13/32	5/8	3/8	1.1
3/4	VF4S-212AH	VS-212	3 3/8	2 1/2	7/16	57/64	1 9/32	57/64	2	2 1/2	1/2	23/32	3/8	1.4
15/16 1	VF4S-215AH VF4S-216AH	VS-215 VS-216	3 3/4	2 3/4	1/2	61/64	1 7/16	61/64	2 1/2	2 3/4	9/16	13/16	7/16	1.6
1 3/16	VF4S-219AH	VS-219	4 1/4	3 1/4	17/32	1 5/64	1 9/16	31/64	2 7/8	3 1/8	5/8	7/8	7/16	2.6
1 1/4 1 7/16	VF4S-220AH VF4S-223AH	VS-220 VS-223	4 5/8	3 5/8	19/32	1 5/32	1 3/4	19/32	3 1/4	3 5/8	11/16	1	1/2	3.6
1 1/2	VF4S-224AH	VS-224	5 1/8	4	5/8	1 19/64	2 1/64	23/32	3 1/2	4 1/8	3/4	1 3/16	1/2	4.9
1 11/16 1 3/4	VF4S-227AH VF4S-228AH	VS-227 VS-228	5 3/8	4 1/8	5/8	1 21/64	2 3/64	23/32	3 7/8	4 3/8	3/4	1 3/16	9/16	5.2
1 15/16	VF4S-231AH	VS-231	5 5/8	4 3/8	5/8	1 23/64	2 5/32	51/64	4	4 9/16	3/4	1 9/32	9/16	5.6
2 3/16	VF4S-235AH	VS-235	6 3/8	5 1/8	13/16	1 33/64	2 5/16	51/64	4 1/4	5 1/4	7/8	1 5/16	5/8	7.9
2 7/16	VF4S-239AH	VS-239	6 7/8	5 5/8	13/16	1 11/16	2 11/16	1	5	5 7/16	1	1 9/16	5/8	9.6

For the most up-to-date bearing cross reference information go to [www.regalrexnord.com](http://www.regalrexnord.com) or call Application Engineering at 1-800-626-2093.

## VPS-300AH

**Lock:** Setscrew  
**Seal:** Contact  
**Housing:** Cast Iron  
**Temperature:** -20° F to 200° F  
**Self Alignment:** ±1.5°  
**Inserts:** VS-300

**V VALUE and QUALITY**  
**P PILLOW BLOCK**  
**S Setscrew**

**3 300**  
**0 MEDIUM**  
**0 DUTY**  
**A AIR**  
**H HANDLING**

Bore Size (in.)	Fitting (in.)
1	1/4 - 28NF
1 3/16 - 3 15/16 S	1/8 NPT

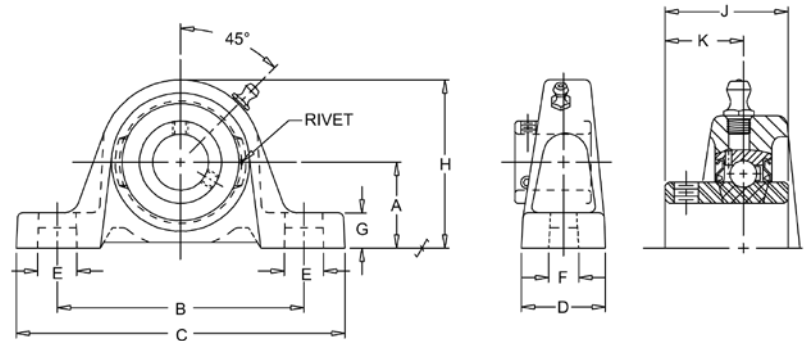

SHAFT DIA. (in.)	UNIT NO.	BRG. NO.	Dimensions (in.)										BOLT SIZE (in.)	UNIT WT.
			A	B	C	D	E	F	G	H	J	K		
1	VPS-316AH	VS-316	1 3/4	4 5/8	6 3/16	1 3/4	15/16	9/16	23/32	3 11/32	1 1/2	7/8	1/2	3.6
1 3/16	VPS-319AH	VS-319	1 7/8	5	6 3/4	1 3/4	7/8	9/16	23/32	3 11/16	1 11/16	1	1/2	4.8
1 7/16	VPS-323AH	VS-323	2 1/8	5 17/32	7 1/4	2	29/32	9/16	13/16	4 3/16	1 15/16	1 3/16	1/2	6.2
1 1/2	VPS-324AH	VS-324	2 5/6	5 31/32	7 13/16	2 3/16	1	11/16	13/16	4 9/16	1 15/16	1 3/16	5/8	8.0
1 11/16 1 3/4	VPS-327AH VPS-328AH	VS-327 VS-328	2 5/6	6 1/8	7 15/16	2 1/4	1	11/16	13/16	4 5/8	2 1/32	1 9/32	5/8	8.0
1 15/16 2	VPS-331AH VPS-332AH	VS-331 VS-232	2 1/2	6 15/16	8 13/16	2 5/16	1	11/16	7/8	4 31/32	2 3/16	1 5/16	5/8	10.5
2 3/16	VPS-335AH	VS-335	2 3/4	7 13/32	9 1/2	2 3/8	1 5/32	11/16	7/8	5 9/16	2 9/16	1 9/16	5/8	14.3

For the most up-to-date bearing cross reference information go to [www.regalrexnord.com](http://www.regalrexnord.com) or call Application Engineering at 1-800-626-2093.

**VALUE & QUALITY V**  
**FLANGE F**  
**TWO BOLT 2**  
**Setscrew S**  
  
**300 3**  
**MEDIUM 0**  
**DUTY 0**  
**AIR A**  
**HANDLING H**

## VF2S-300AH

**Lock:** Setscrew  
**Seal:** Contact  
**Housing:** Cast Iron  
**Temperature:** -20° F to 200° F  
**Self Alignment:** ±1.5°  
**Inserts:** VS-300

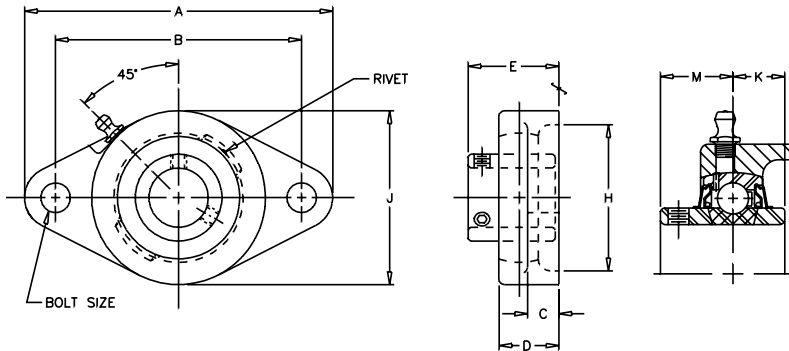

Bore Size (in.)	Fitting (in.)
1	1/4 - 28NF
1 3/16 - 2 S	1/8 NPT

SHAFT DIA. (in.)	UNIT NO.	BRG. NO.	Dimensions (in.)									BOLT SIZE (in.)	UNIT WT.
			A	B	C	D	E	H CORED	J	K	M		
1	VF2S-316AH	VS-316	5 9/16	4 19/32	17/32	1 5/64	1 9/16	2 3/4	3 1/8	5/8	7/8	7/16	2.7
1 3/16	VF2S-319AH	VS-319	6 1/8	5 1/8	19/32	1 5/32	1 3/4	3 3/16	3 5/8	11/16	1	1/2	2.7
1 7/16	VF2S-323AH	VS-323	6 3/4	5 21/32	5/8	1 19/64	2 1/64	3 1/2	4 1/8	3/4	1 3/16	1/2	4.8
1 1/2	VF2S-324AH	VS-324	7 1/16	5 27/32	5/8	1 21/64	2 3/64	3 3/4	4 3/8	3/4	1 3/16	9/16	4.8
1 11/16 1 3/4	VF2S-327AH VF2S-328AH	VS 327 VS-328	7 7/16	6 3/16	5/8	2 5/32	2 5/32	4	4 91/6	3/4	1 9/32	9/16	7.6

For the most up-to-date bearing cross reference information go to [www.regalrexnord.com](http://www.regalrexnord.com) or call Application Engineering at 1-800-626-2093.

## VF4S-300AH

**Lock:** Setscrew  
**Seal:** Contact  
**Housing:** Cast Iron  
**Temperature:** -20° F to 200° F  
**Self Alignment:** ±1.5°  
**Inserts:** VS-300

**V VALUE and QUALITY**  
**F FLANGE BLOCK**  
**4 FOUR BOLT**  
**S Setscrew**  
  
**3 300**  
**0 MEDIUM**  
**0 DUTY**  
**A AIR**  
**H HANDLING**

Bore Size (in.)	Fitting (in.)
1	1/4 - 28NF
1 3/16 - 3 15/16 S	1/8 NPT

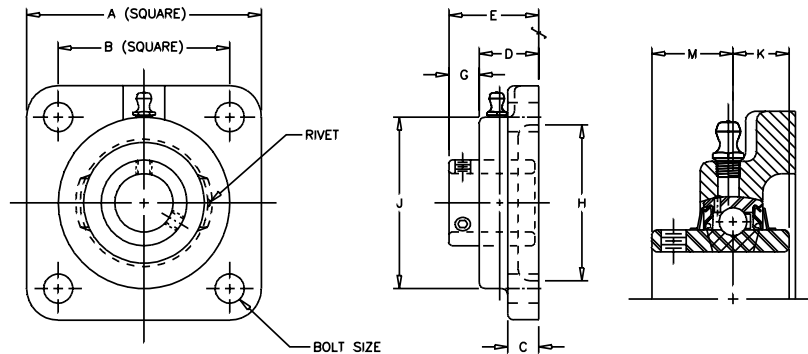

SHAFT DIA. (in.)	UNIT NO.	BRG. NO.	Dimensions (in.)										BOLT SIZE (in.)	UNIT WT.
			A	B	C	D	E	G	H CORED	J	K	M		
1 3/16	VF4S-319AH	VS-319	4 5/8	3 5/8	19/32	1 5/32	1 3/4	19/32	3 1/4	3 5/8	11/16	1	1/2	2.9
1 7/16	VF4S-323AH	VS-323	5 1/8	4	5/8	1 19/64	2 1/64	23/32	3 1/2	4 1/8	3/4	1 3/16	1/2	5.0
1 1/2	VF4S-324AH	VS-324	5 3/8	4 1/8	5/8	1 21/64	2 3/4	23/32	3 7/8	4 3/8	3/4	1 3/16	9/16	5.0
1 11/16	VF4S-327AH	VS-327	5 5/8	4 3/8	5/8	1 23/64	2 5/32	51/64	4	4 9/16	3/4	1 9/32	9/16	5.8
1 15/16	VF4S-331AH	VS-331	6 3/8	5 1/8	13/16	1 33/64	2 5/16	51/64	4 1/4	5 1/4	7/8	1 5/16	5/8	8.0
2 3/16 2 1/4	VF4S-335AH VF4S-336AH	VS-335 VS-236	6 7/8	5 5/8	13/16	1 11/16	2 11/16	1	5	5 7/16	1	1 9/16	5/8	9.9
2 7/16 2 1/2	VF4S-339AH VF4S-340AH	VS-339 VS-340	7 3/8	5 7/8	13/16	1 49/64	2 7/8	1 7/64	5 1/8	6 1/8	1 1/16	1 11/16	5/8	13.3

For the most up-to-date bearing cross reference information go to [www.regalrexnord.com](http://www.regalrexnord.com) or call Application Engineering at 1-800-626-2093.

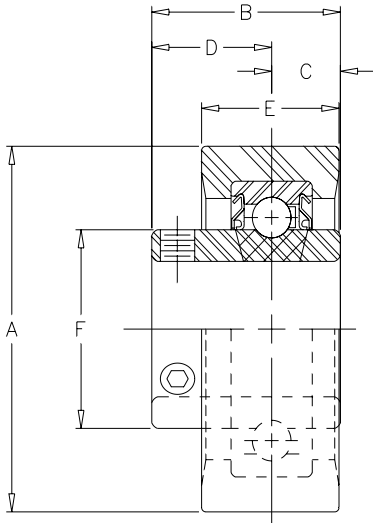

RUBBER R  
GROMMET U  
STRAIGHT OD B  
INSERT R  
Setscrew S

## RUBRS-100

Lock: Setscrew  
Seal: Contact  
Housing: Rubber Grommet  
Temperature: -20° F to 200° F  
Inserts: SLS-100

100 1  
LIGHT 0  
DUTY 0

No Re-Lube

SHAFT DIA. (in.)	MAX STEADY RADIAL LOAD LBS.	UNIT NO.	BRG. NO.	Dimensions (in.)						UNIT WT.
				A	B	C	D	E	F	
1/2	250	RUBRS-108	SLRS-108	2 17/32	1 9/32	13/32	7/8	1	1 3/16	0.5
5/8		RUBRS-110	SLRS-110							
3/4		RUBRS-112	SLRS-112							
15/16	300	RUBRS-115	SLRS-115	2 17/32	1 3/8	1/2	7/8	1	13/8	0.64
1		RUBRS-116	SLRS-116							

## CONCENTRIC

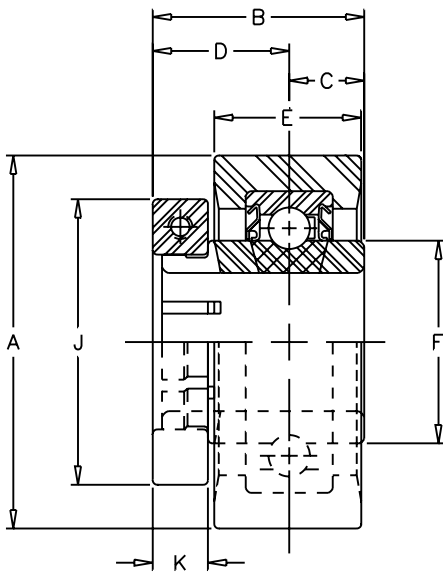

RUBBER R  
GROMMET U  
STRAIGHT OD B  
INSERT R  
BOA CONCENTRIC B

## RUBRB-100

Lock: Setscrew  
Seal: Contact  
Housing: Rubber Grommet  
Temperature: -20° F to 200° F  
Inserts: SLRB-100

100 1  
LIGHT 0  
DUTY 0

No Re-Lube

SHAFT DIA. (in.)	MAX STEADY RADIAL LOAD LBS.	UNIT NO.	BRG. NO.	Dimensions (in.)								UNIT WT.
				A	B	C	D	E	F	J	K	
3/4	250	RUBRB-112	SLRB-112	2 17/32	1 9/32	1 3/32	13/16	1	1 3/16	1 3/4	3/8	.70
1	300	RUBRB-116	SLRB-116	2 17/32	1 7/16	33/64	59/64	1	1 3/8	1 15/16	3/8	.85

## SSRPS-100

**Lock:** Setscrew  
**Seal:** Contact  
**Housing:** Stamped Steel  
           Rubber Grommet  
**Temperature:** -20° F to 200° F  
**Inserts:** LRS-100

No Re-Lube

**S STAMPED**  
**S STEEL**  
**R RUBBER GROMMET**  
**P PILLOW BLOCK**  
**S Setscrew**

**1 100**  
**0 LIGHT**  
**0 DUTY**

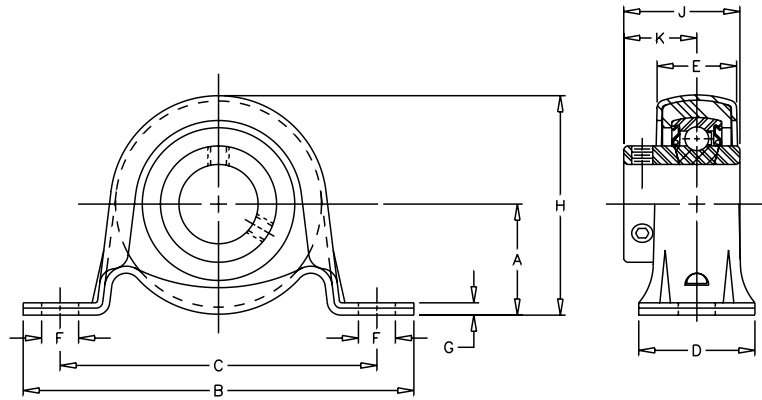

SHAFT DIA. (in.)	MAX STEADY RADIAL LOAD LBS.	UNIT NO.	Dimensions (in.)										UNIT WT.
			A	B	C	D	E	F	G	H	J	K	
3/4	250	SSRPS-112	1 1/8	4 1/4	3 3/8	1 1/4	27/32	7/16	1/8	2 13/64	1 7/32	1 7/32	0.6
7/8	300	SSRPS-114	1 5/16	4 5/8	3 3/4	1 3/8	61/64	7/16	5/32	2 19/32	1 3/8	1 3/8	0.8
15/16		SSRPS-115											
1		SSRPS-116											

For the most up-to-date bearing cross reference information go to [www.regalrexnord.com](http://www.regalrexnord.com) or call Application Engineering at 1-800-626-2093.

STAMPED S  
STEEL S  
PILLOW BLOCK P  
Setscrew

100 1  
LIGHT 0  
DUTY 0

## SSPS-100

**Lock:** Setscrew  
**Seal:** Contact  
**Housing:** Stamped Steel  
**Temperature:** -20° F to 200° F  
**Inserts:** LRS-100

No Re-Lube

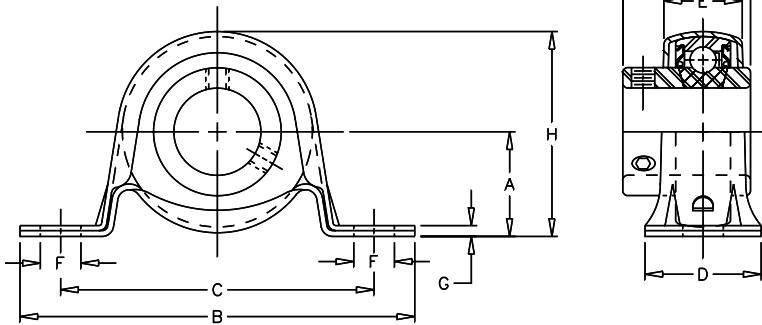

SHAFT DIA. (in.)	MAX STEADY RADIAL LOAD LBS.	UNIT NO.	BRG. NO.	Dimensions (in.)										UNIT WT.
				A	B	C	D	E	F	G	H	K	M	
7/8	400	SSPS-114	LRS-114											
15/16		SSPS-115	LRS-115	1 1/8	4 1/4	3 3/8	1 1/4	27/32	7/16	1/8	2 13/64	7/8	1 3/8	.06
1		SSPS-116	LRS-116											
1 1/8	600	SSPS-118	LRS-118											
1 3/16		SSPS-119	LRS-119	1 5/16	4 5/8	3 3/4	1 3/8	61/64	7/16	5/32	2 19/32	7/8	1 19/32	1.0
1 1/4		SSPS-120S	LRS-120S											

For the most up-to-date bearing cross reference information go to [www.regalrexnord.com](http://www.regalrexnord.com) or call Application Engineering at 1-800-626-2093.

## SSF2S-100

**Lock:** Setscrew  
**Seal:** Contact  
**Housing:** Stamped Steel  
**Temperature:** -20° F to 200° F  
**Inserts:** LS-100

**S STAMPED**  
**S STEEL**  
**F FLANGE**  
**2 TWO BOLT**  
**S Setscrew**  
**1 100**  
**0 LIGHT**  
**0 DUTY**

No Re-Lube

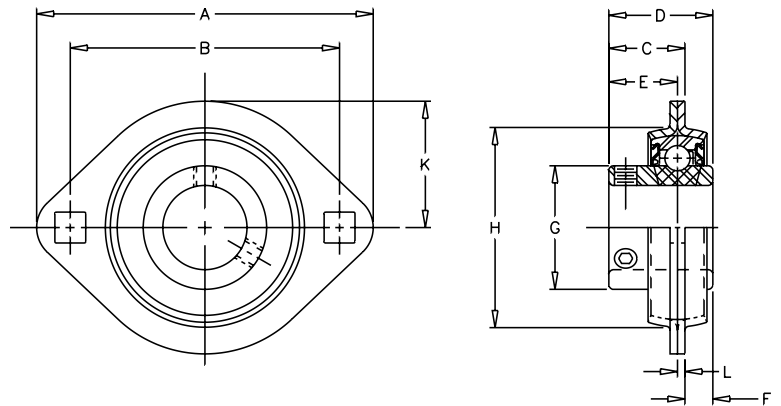

SHAFT DIA. (in.)	MAX STEADY RADIAL LOAD LBS.	UNIT NO.	BRG. NO.	Dimensions (in.)										BOLT SIZE	UNIT WT.
				A	B	C	D	E	F	G	H	K	L		
1/2	600	SSF2S-108	LS-108	3 3/16	2 1/2	45/64	15/16	5/8	15/64	31/32	1 47/64	1 1/8	.075	1/4	.6
5/8		SSF2S-110	LS-110												
3/4	600	SSF2S-112	LS-112	3 9/16	2 13/16	51/64	1 1/16	23/32	1/4	1 3/16	2 1/64	1 5/16	.083	5/16	.8
7/8	800	SSF2S-114	LS-114	3 3/4	3	55/64	1 7/64	49/64	1/4	1 3/8	2 7/32	1 13/32	.083	5/16	.9
15/16		SSF2S-115	LS-115												
1		SSF2S-116	LS-116												
1 1/8	1100	SSF2S-118	LS-118	4 7/16	3 9/16	57/64	1 5/32	25/32	17/64	1 19/32	2 21/32	1 21/32	.104	3/8	1.0
1 3/16		SSF2S-119	LS-119												
1 1/4		SSF2S-120S	LS-120S												

For the most up-to-date bearing cross reference information go to [www.regalrexnord.com](http://www.regalrexnord.com) or call Application Engineering at 1-800-626-2093.

**STAMPED S**  
**STEEL S**  
**FLANGE F**  
**FOUR BOLT 4**  
**Setscrew S**  
  
**100 1**  
**LIGHT 0**  
**DUTY 0**

## SSF4S-100

**Lock:** Setscrew  
**Seal:** Contact  
**Housing:** Stamped Steel  
**Temperature:** -20° F to 200° F  
**Inserts:** LS-100

No Re-Lube

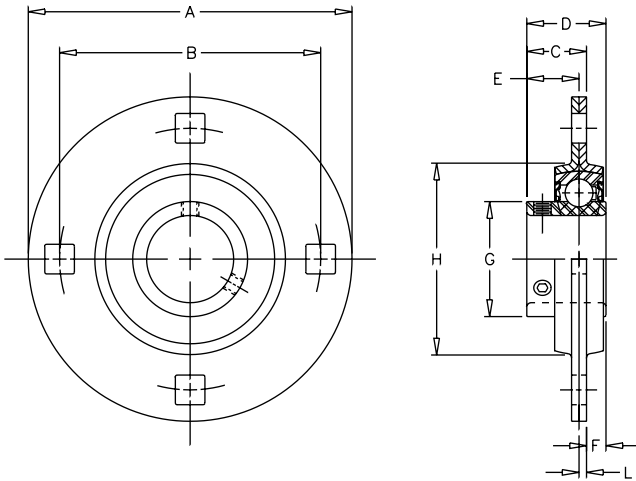

SHAFT DIA. (in.)	MAX STEADY RADIAL LOAD LBS.	UNIT NO.	BRG No.	Dimensions (in.)									BOLT SIZE	UNIT WT.
				A	B	C	D	E	F	G	H	L		
1 1/2	1700	SSF4S-124	LS-124	5 13/16	4 11/16	1 5/64	1 27/64	15/16	11/32	2 1/16	3 7/16	.134	1/2	3.5
1 11/16 1 3/4	1700	SSF4S-127 SSF4S-128	LS-127 LS-128	5 7/8	4 3/4	1 3/32	1 7/16	6 1/64	11/32	2 19/64	3 5/8	.134	1/2	3.9
1 15/16	1900	SSF4S-131	LS-131	6 1/8	5	1 3/16	1 35/64	1 3/64	23/64	2 15/32	3 27/32	.149	1/2	4.0

For the most up-to-date bearing cross reference information go to [www.regalrexnord.com](http://www.regalrexnord.com) or call Application Engineering at 1-800-626-2093.

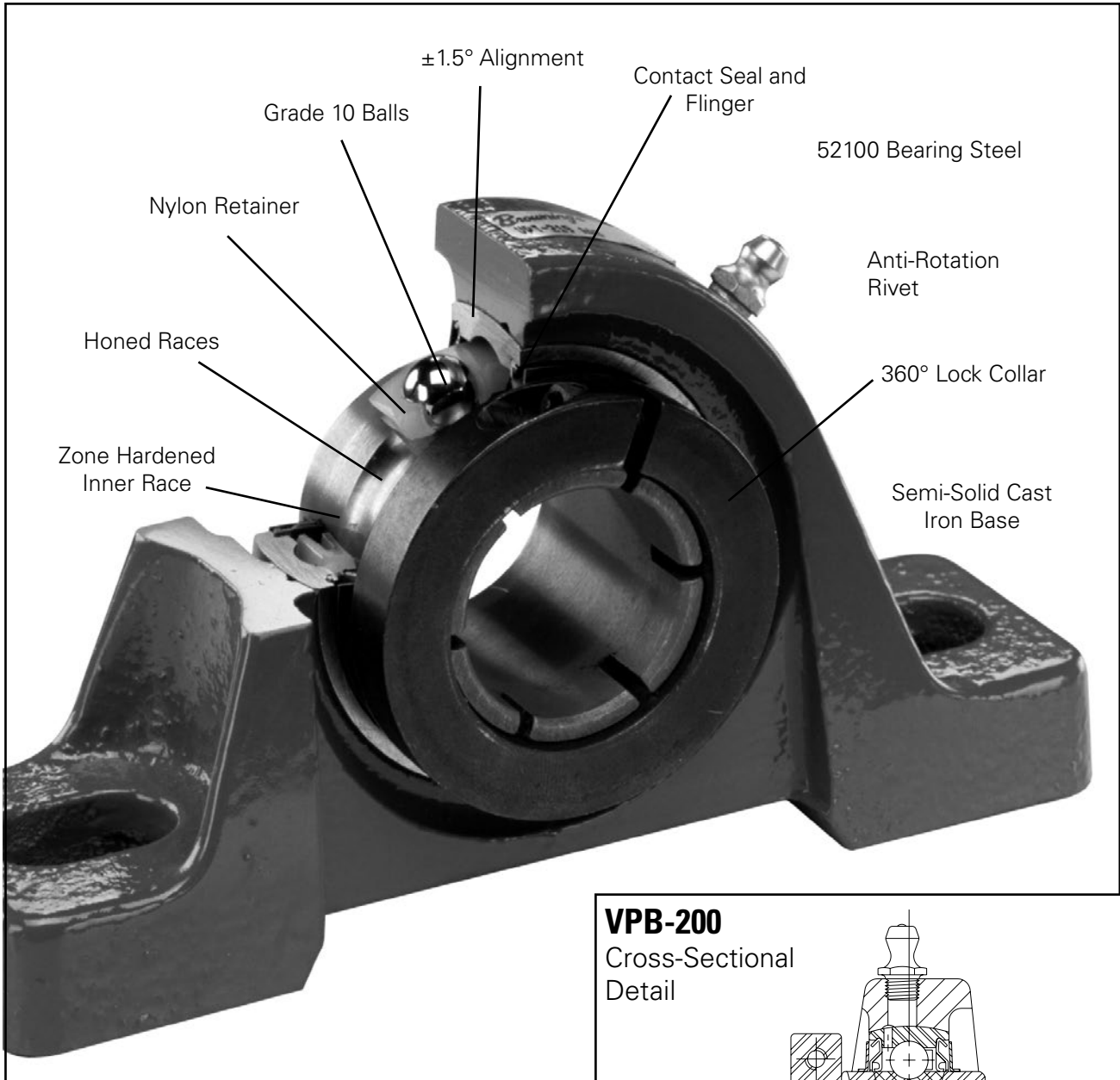

**VPB-200**

Cross-Sectional Detail

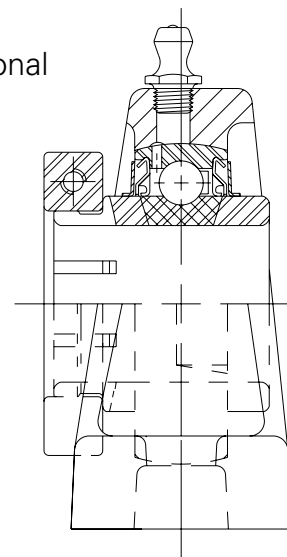

**BROWNING®**  
**CONCENTRIC**  
**BALL BEARINGS**  
**FEATURES/BENEFITS**

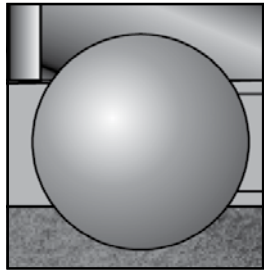

## GRADE 10 BALLS

For quieter operation and less vibration. Manufactured with high quality 52100 steel.

## SUPERIOR 360 LOCKING

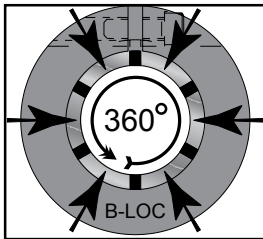

The Browning® concentric locking collar with a single cap screw provides excellent holding power. The collar is installed over the slotted inner ring on the shaft concentrically. Designed for no shaft marring or burring with minimal runout for less vibration.

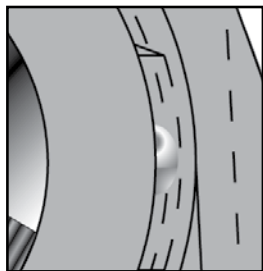

## ANTI-ROTATION RIVET

An anti-rotation rivet prevents outer ring creep or rotation within the housing. This reduces heat buildup and prolongs useful bearing life.

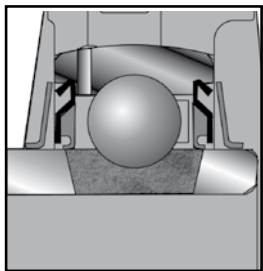

## CONTACT SEAL

Positive contact molded rubber lip with an auxiliary flinger for proven effective sealing against contaminants.

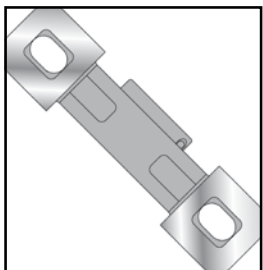

## SEMI-SOLID CAST IRON BASE

The rugged base design provides an excellent mounting foundation. This is integral to prevent sheet metal "buckling."

## PRECISION HARDENED AND HONED RINGS

Inner rings are zone hardened to maintain ballpath hardness while keeping inner ring extension soft for a precision fit with the concentric collar. Both ballpaths are honed for quieter operation and less vibration. See cross-section detail – left.

# BALL BEARINGS

## FEATURES/BENEFITS

## SERIES

Browning concentric ball bearings are segmented into two series: normal duty for general purpose use and medium duty for heavier loads.

200 = Normal duty  
300 = Medium duty

## SELECT FEATURES

Browning ball bearings incorporate a unique concentric locking collar design for better grip on the shaft and less vibration during operation. The concentric clamp collar, with a single cap screw, provides increased reliability without marring or burring the shaft. The 360° clamping force reduces vibration through improved concentricity.

## RELATED PRODUCTS

Browning concentric "off the shelf" ball bearings are available in popular **Air Handling** pillow block shaft sizes ranging from 3/4" to 2 7/16". **Air Handling** features may be added to other Browning B-loc units simply by designating "**AH**" as a suffix to the base nomenclature. Example: VF2B 216 AH. Contact Regal Rexnord for availability of non stock **AH** units.

## VPB-200AH

**Lock:** Concentric  
**Seal:** Contact  
**Housing:** Cast Iron  
**Temperature:** -20° F to 200° F  
**Self Alignment:** ±1.5°  
**Insert:** VB-200

**V** VALUE and QUALITY  
**P** PILLOW BLOCK  
**B** BOA  
**2** 200  
**0** NORMAL  
**0** DUTY  
**A** AIR  
**H** HANDLING

**CONCENTRIC**

Bore Size (in.)	Fitting (in.)
3/4 - 1 3/16	1/4 - 28NF
1 7/16 - 2 7/16	1/8 NPT

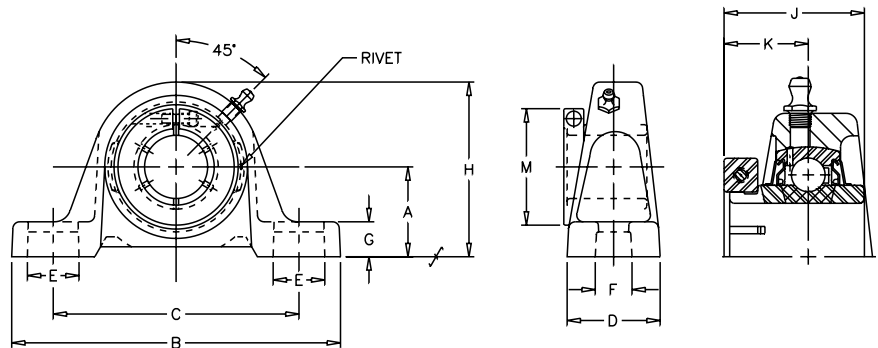

SHAFT DIA. (in.)	UNIT NO.	BRG NO.	Dimensions (in.)												BOLT SIZE (in.)	UNIT WT.
			A	B	C		D	E	F	G	H	J	K	M		
					MIN.	MAX.										
3/4	VPB-212AH	VB-212	1 5/16	5	3 3/8	4 3/16	1 11/32	25/32	7/16	17/32	2 17/32	1 9/32	25/32	1 3/4	3/8	1.60
1	VPB-216AH	VB-216	1 7/16	5 1/2	3 11/16	4 9/16	1 13/32	13/16	7/16	19/32	2 13/32	1 7/16	7/8	1 15/16	3/8	1.90
1 3/16	VPB-219AH	VB-219	1 11/16	6 3/16	4 3/16	5 1/16	1 3/4	15/16	9/16	21/32	3 9/32	1 9/16	15/16	2 3/16	1/2	2.90
1 7/16	VPB-223AH	VB-223	1 7/8	6 3/4	4 5/8	5 3/8	1 3/4	7/8	9/16	23/32	3 11/16	1 3/4	1 1/16	2 7/16	1/2	3.80
1 11/16	VPB-227AH	VB-227	2 1/8	7 3/8	5 1/4	6 1/16	2	29/32	9/16	3/4	4 1/4	2	1 1/4	2 15/16	1/2	5.60
1 11/16	VPB-231AH	VB-231	2 1/4	8	5 7/8	6 1/2	2 3/16	15/16	11/16	3/4	4 9/16	2 3/32	1 11/32	3 3/8	5/8	6.20
2 3/16	VPB-235AH	VB-235	2 1/2	8 13/16	6 7/16	7 7/16	2 5/16	1	11/16	7/8	4 31/32	2 1/4	1 3/8	3 5/8	5/8	8.00
2 7/16	VPB-239AH	VB-239	2 3/4	9 1/2	6 7/8	7 15/16	2 3/8	1 5/32	11/16	7/8	5 9/16	2 5/8	1 5/8	4 1/8	5/8	10.10

For the most up-to-date bearing cross reference information go to [www.regalrexnord.com](http://www.regalrexnord.com) or call Application Engineering at 1-800-626-2093.

## CONCENTRIC

VALUE & QUALITY V  
PILLOW BLOCK P  
BOA B

300 3  
MEDIUM 0  
DUTY 0

## VPB-300

**Lock:** BOA Concentric  
**Seal:** Contact  
**Housing:** Cast Iron  
**Temperature:** -20° F to 200° F  
**Self Alignment:** ±1.5°  
**Inserts:** VB-200

Bore Size (in.)	Fitting (in.)
1	1/4 - 28NF
1 3/16 - 2 3/16	1/8 NPT

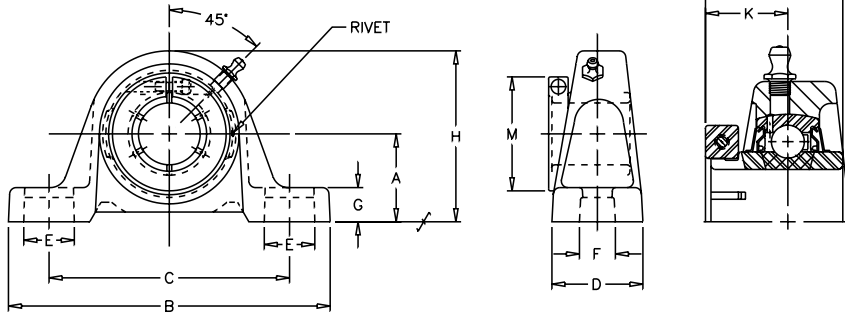

SHAFT DIA. (in.)	UNIT NO.	BRG NO.	Dimensions (in.)											BOLT SIZE (in.)	UNIT WT.	
			A	B	C		D	E	F	G	H	J	K			M
					MIN.	MAX.										
1	VPB-316	VB-316	1 3/4	6 3/16	4 3/16	5 1/6	1 3/4	15/16	9/16	23/32	3 11/32	1 9/16	15/16	2 1/16	1/2	3.1
1 3/16	VPB-319	VB-319	1 7/8	6 3/4	4 5/8	5 3/8	1 3/4	7/8	9/16	23/32	3 11/16	1 3/4	1 1/16	2 7/16	1/2	3.1
1 7/16	VPB-323	VB-323	2 1/8	7 1/4	5 1/8	5 15/16	2	29/32	9/16	13/16	4 3/16	2	1 1/4	2 11/16	1/2	3.9
1 11/16	VPB-327	VB-327	2 5/16	7 15/16	5 3/4	6 1/2	2 1/4	1	11/16	13/16	4 5/8	2 3/32	1 11/32	3 1/4	5/8	5.8
1 15/16	VPB-331	VB-331	2 1/2	8 13/16	6 7/16	7 7/16	2 5/16	1	11/16	7/8	4 31/32	2 1/4	1 3/8	3 1/2	5/8	8.1
2	VPB-332	VB-232														
2 3/16	VPB-335	VB-335	2 3/4	9 1/2	6 7/8	7 15/16	2 3/8	1-5/32	11/16	7/8	5 9/16	2 5/8	1 5/8	4 1/16	5/8	10.4

For the most up-to-date bearing cross reference information go to [www.regalrexnord.com](http://www.regalrexnord.com) or call Application Engineering at 1-800-626-2093.

For additional product information, visit [www.regalrexnord.com/Browning](http://www.regalrexnord.com/Browning)

## 100 SERIES RATINGS

This chart displays all 100 series ball bearings' load capacity for a given L10 life, speed, and shaft size. Values in the table represent loads at ideal conditions with press fit mounting to the shaft. ABMA recommends de-rating of slip fit mounted bearings. To obtain de-rated load, divide load in table by 1.3. Values in the table represent equivalent radial loads only.

Match Bore Size

100 Shaft Size	L10 HOURS	REVOLUTIONS PER MINUTE															
		50	150	250	500	750	1000	1500	1750	2000	2500	3000	3500	4000	45000	5000	5500
1/2 5/8 275	5000	315	315	315	315	315	315	275	261	250	323	218	207	198	191	184	-
	10000	315	315	315	315	275	250	218	207	198	184	173	165	157	151	146	-
	250	315	315	275	218	191	173	151	144	138	128	120	114	109	105	101	-
	50000	315	275	232	184	161	146	128	121	116	108	101	96	92	89	85	-
3/4	100000	315	218	184	146	128	116	101	96	92	85	80	76	73	70	68	-
	5000	390	390	390	390	390	390	341	324	310	287	270	257	246	-	-	-
	10000	390	390	390	390	341	310	270	257	246	228	215	204	195	-	-	-
	30000	390	390	341	270	236	215	188	178	170	158	149	141	135	-	-	-
7/8 15/16 1	50000	390	341	287	228	199	181	158	150	144	133	126	119	114	-	-	-
	100000	390	270	228	181	158	144	126	119	114	106	100	95	91	-	-	-
	5000	418	418	418	418	418	418	366	347	332	308	290	276	-	-	-	-
	10000	418	418	418	418	418	366	332	290	279	264	245	230	219	-	-	-
1 1/8 1 3/16 1 1/4	30000	418	418	366	290	253	230	201	191	183	170	160	152	-	-	-	-
	50000	418	366	308	245	214	194	170	161	154	143	135	128	-	-	-	-
	100000	418	290	245	194	170	154	135	128	122	114	107	102	-	-	-	-
	5000	654	654	654	654	654	654	572	543	519	482	454	-	-	-	-	-
1 1/4 1 3/8 1 7/16	10000	654	654	654	654	572	519	454	431	412	383	360	-	-	-	-	-
	30000	654	654	572	454	396	360	315	299	286	265	250	-	-	-	-	-
	50000	654	572	482	383	334	304	265	252	241	224	211	-	-	-	-	-
	100000	654	454	383	304	255	241	211	200	191	178	167	-	-	-	-	-
1 1/2	5000	864	864	864	864	864	864	755	717	686	636	-	-	-	-	-	-
	10000	864	864	864	864	755	686	599	569	544	505	-	-	-	-	-	-
	30000	864	864	755	599	523	475	415	394	377	350	-	-	-	-	-	-
	50000	864	755	636	505	441	401	350	333	318	295	-	-	-	-	-	-
1 11/16 1 3/4	100000	864	599	505	401	350	318	278	264	253	234	-	-	-	-	-	-
	5000	1096	1096	1096	1096	1096	1096	958	910	870	808	-	-	-	-	-	-
	10000	1096	1096	1096	1096	958	870	760	722	691	641	-	-	-	-	-	-
	30000	1096	1096	958	760	664	603	527	501	479	445	-	-	-	-	-	-
1 15/16 2	50000	1096	958	808	641	560	509	445	422	404	375	-	-	-	-	-	-
	100000	1096	760	641	509	445	404	353	335	321	298	-	-	-	-	-	-
	5000	1180	1180	1180	1180	1180	1180	1031	979	937	-	-	-	-	-	-	-
	10000	1180	1180	1180	1180	1031	937	818	777	744	-	-	-	-	-	-	-
2 2 3/16	30000	1180	1180	1031	818	715	650	567	539	516	-	-	-	-	-	-	-
	50000	1180	1031	870	690	603	548	479	455	435	-	-	-	-	-	-	-
	100000	1180	818	690	548	479	435	380	361	345	-	-	-	-	-	-	-
	5000	1457	1457	1457	1457	1457	1457	1273	1209	-	-	-	-	-	-	-	-
2 3/16	10000	1457	1457	1457	1457	1273	1156	1010	959	-	-	-	-	-	-	-	-
	30000	1457	1457	1273	1010	882	802	700	665	-	-	-	-	-	-	-	-
	50000	1457	1273	1073	852	744	676	591	561	-	-	-	-	-	-	-	-
	100000	1457	1010	852	676	591	537	469	445	-	-	-	-	-	-	-	-



# BALL BEARINGS

## 200 SERIES RATINGS

This chart displays 200 series ball bearings' load capacity for a given L10 life, speed, and shaft size. Values in the table represent loads at ideal conditions with press fit mounting to the shaft. ABMA recommends de-rating of slip fit mounted bearings. To obtain de-rated load, divide load in table by 1.3. Values in the table represent equivalent radial loads only.

Match Bore Size

SHAFT SIZES 200 Dia. Inches	L10 Hours	REVOLUTIONS PER MINUTE																	
		50	150	250	500	750	1000	1500	1750	2000	2500	3000	3500	4000	4500	5000	5500	6500	7500
1/2 5/8	5000	500	500	500	397	347	315	275	261	250	232	218	207	198	191	184	178	169	161
	10000	500	470	397	315	275	250	218	207	198	184	173	165	157	151	146	142	134	128
	30000	470	326	275	218	191	173	151	144	138	128	120	114	109	105	101	98	93	89
	50000	397	275	232	184	161	146	128	121	116	108	101	96	92	89	85	83	78	75
3/4	100000	315	218	184	146	128	116	101	96	92	85	80	76	73	70	68	66	62	59
	5000	619	619	619	491	429	390	341	324	310	287	270	257	246	236	228	221	209	-
	10000	583	583	491	390	341	310	270	257	246	228	215	204	195	188	181	175	166	-
	30000	583	404	341	270	236	215	188	178	170	158	149	141	135	130	126	122	115	-
7/8 15/16 1	50000	491	341	287	228	199	181	158	150	144	133	126	119	114	110	106	103	97	-
	100000	390	270	228	181	158	144	126	119	114	106	100	95	91	87	84	81	77	-
	5000	664	664	664	527	461	418	366	347	332	308	290	276	264	253	245	237	-	-
	10000	625	625	527	418	366	332	290	276	264	245	230	219	209	201	194	188	-	-
1 1/8 1 3/16 1 1/4	30000	625	433	366	290	253	230	201	191	183	170	160	152	145	139	135	130	-	-
	50000	527	366	308	245	214	194	170	161	154	143	135	128	122	188	114	110	-	-
	100000	418	290	245	194	170	154	135	128	122	114	107	102	97	93	90	87	-	-
	5000	1039	1039	1039	825	720	654	572	543	519	482	454	431	412	396	-	-	-	-
1 1/4 1 3/8 1 7/16	10000	978	978	825	654	572	519	454	431	412	383	360	342	327	315	-	-	-	-
	30000	978	678	572	454	396	390	315	299	286	265	250	237	227	218	-	-	-	-
	50000	825	572	482	383	334	304	265	252	241	224	211	200	191	184	-	-	-	-
	100000	654	454	383	304	265	241	211	200	191	178	167	159	152	146	-	-	-	-
1 1/2	5000	1290	1290	1290	1088	951	864	755	717	686	636	599	569	544	-	-	-	-	-
	10000	1290	1290	1088	864	755	686	599	569	544	505	475	452	432	-	-	-	-	-
	30000	1290	895	755	599	523	475	415	394	377	350	330	313	299	-	-	-	-	-
	50000	1088	755	636	505	441	401	350	333	318	295	278	264	253	-	-	-	-	-
1 5/8 1 11/16 1 3/4	100000	864	599	505	401	350	318	278	264	253	234	221	210	200	-	-	-	-	-
	5000	1638	1638	1638	1381	1207	1096	958	910	870	808	760	722	-	-	-	-	-	-
	10000	1638	1638	1381	1096	958	870	760	722	691	641	603	573	-	-	-	-	-	-
	30000	1638	1136	958	760	664	603	527	501	479	445	418	397	-	-	-	-	-	-
1 15/16 2	50000	1381	958	808	641	560	509	445	422	404	375	353	335	-	-	-	-	-	-
	100000	1096	760	641	509	445	404	353	335	321	298	280	266	-	-	-	-	-	-
	5000	1763	1763	1763	1487	1299	1180	1031	979	937	870	818	-	-	-	-	-	-	-
	10000	1763	1763	1487	1180	1031	937	818	777	744	690	650	-	-	-	-	-	-	-
2 2 3/16	30000	1763	1222	1031	818	715	650	567	539	516	479	450	-	-	-	-	-	-	-
	50000	1487	1031	870	690	603	548	479	455	435	404	380	-	-	-	-	-	-	-
	100000	1180	818	690	548	479	435	380	361	345	320	301	-	-	-	-	-	-	-
	5000	1760	1760	1760	1485	1297	1178	1029	978	935	868	817	-	-	-	-	-	-	-
2 1/4 2 7/16	10000	1760	1760	1485	1178	1029	935	817	7769	742	689	649	-	-	-	-	-	-	-
	30000	1760	1221	1029	817	714	649	567	538	515	478	450	-	-	-	-	-	-	-
	50000	1485	1029	868	689	602	547	478	454	434	403	379	-	-	-	-	-	-	-
	100000	1178	817	689	547	478	434	379	360	345	320	301	-	-	-	-	-	-	-
2 3/8	5000	2176	2176	2176	1835	1603	1457	1273	1209	1156	1073	-	-	-	-	-	-	-	-
	10000	2176	2176	1835	1457	1273	1156	1010	959	918	852	-	-	-	-	-	-	-	-
	30000	2176	1509	1273	1010	882	802	700	665	636	591	-	-	-	-	-	-	-	-
	50000	1835	1273	1073	852	744	676	591	561	537	498	-	-	-	-	-	-	-	-
2 1/2	100000	1457	1010	852	676	591	537	469	445	426	395	-	-	-	-	-	-	-	-
	5000	2631	2631	2631	2219	1938	1761	1538	1461	1398	1298	-	-	-	-	-	-	-	-
	10000	2631	2631	2219	1761	1538	1398	1221	1160	1109	1030	-	-	-	-	-	-	-	-
	30000	2631	1824	1538	1221	1067	969	847	804	769	714	-	-	-	-	-	-	-	-
2 5/8	50000	2219	1538	1298	1030	900	817	714	678	649	602	-	-	-	-	-	-	-	-
	100000	1761	1221	1030	817	714	649	567	538	515	478	-	-	-	-	-	-	-	-

## 300 SERIES RATINGS

This chart displays 300 series ball bearings' load capacity for a given L10 life, speed, and shaft size. Values in the table represent loads at ideal conditions with press fit mounting to the shaft. ABMA recommends de-rating of slip fit mounted bearings. To obtain de-rated load, divide load in table by 1.3. Values in the table represent equivalent radial loads only.

Match Bore Size

SHAFT SIZES 300 Dia. Inches	L10 HOURS	REVOLUTIONS PER MINUTE													
		50	150	250	500	750	1000	1500	1750	2000	2500	3000	3500	4000	4500
1	5000	1039	1039	1039	825	720	654	572	543	519	482	454	431	412	-
	10000	978	978	825	654	572	519	454	431	412	383	360	342	327	-
	30000	978	678	572	454	396	360	315	299	286	265	250	237	227	-
	50000	825	572	482	383	334	304	265	252	241	224	211	200	191	-
	100000	654	454	383	304	265	241	211	200	191	178	167	159	152	-
1 3/16 1 1/4	5000	1290	10290	1290	1088	951	864	755	717	686	636	599	569	544	-
	10000	1290	1290	1088	864	755	686	599	569	544	505	475	452	432	-
	30000	1290	895	755	599	523	475	415	394	377	350	330	313	299	-
	50000	1088	755	636	505	441	401	350	333	318	295	278	264	253	-
	100000	864	599	505	401	350	318	278	264	253	234	221	210	200	-
1 7/16	5000	1638	1638	1638	1381	1207	1096	958	910	870	808	760	722	-	-
	10000	1638	1638	1381	1096	958	870	760	722	691	641	603	573	-	-
	30000	1638	1136	958	760	664	603	527	501	479	445	418	397	-	-
	50000	1381	958	808	641	560	509	445	422	404	375	353	335	-	-
	100000	1096	760	641	509	445	404	353	335	321	298	280	266	-	-
1 1/2	5000	1763	1763	1763	1487	1299	1180	1031	979	937	870	818	-	-	-
	10000	1763	1763	1487	1180	1031	937	818	777	744	690	650	-	-	-
	30000	1763	1222	1031	818	715	650	567	539	516	479	450	-	-	-
	50000	1487	1031	870	690	603	548	479	455	435	404	380	-	-	-
	100000	1180	818	690	548	479	435	380	361	345	320	301	-	-	-
1 11/16 1 3/4	5000	1760	1760	1760	1485	1297	1178	1029	978	935	868	817	-	-	-
	10000	1760	1760	1485	1178	1029	935	817	776	742	689	649	-	-	-
	30000	1760	1221	1029	817	714	649	567	538	515	478	450	-	-	-
	50000	1485	1029	868	689	602	547	478	454	434	403	379	-	-	-
	100000	1178	817	689	547	478	434	379	360	345	320	301	-	-	-
1 15/16 2	5000	2176	2176	2176	1835	1603	1457	1273	1290	1156	1073	-	-	-	-
	10000	2176	2176	1835	1457	1273	1156	1010	959	918	852	-	-	-	-
	30000	2176	1509	1273	1010	882	802	700	665	636	591	-	-	-	-
	50000	1835	1273	1073	852	744	676	591	561	537	498	-	-	-	-
	100000	1457	1010	852	676	591	537	469	445	426	395	-	-	-	-
2 3/16	5000	2631	2631	2631	2219	1938	1761	1538	1461	1398	1298	-	-	-	-
	10000	2631	2631	2219	1761	1538	1398	1221	1160	1109	1030	-	-	-	-
	30000	2631	1824	1538	1221	1067	969	847	804	769	714	-	-	-	-
	50000	2219	1538	1298	1030	900	817	714	678	649	602	-	-	-	-
	100000	1761	1221	1030	817	714	649	567	538	515	478	-	-	-	-

# Browning®

**...Drive Tighteners, Idlers, Idler Bushings, Set Collars, Keystock and Cast Iron Bars**  
**A wide variety of specialized products for automatic production.**

New Browning power transmission products are available on a continuous basis to broaden the industry's already widest line. As part of this ongoing program, Regal Rexnord today offers a wide variety of drive tighteners, idlers, idler bushings, set collars, and many other power transmission products.

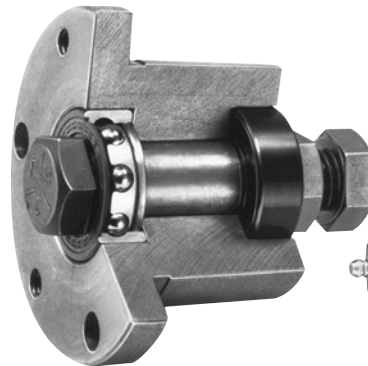

**Idler Bushings**



**Adjusting Tighteners**



**Fixed Flange Tighteners**



**Fixed Angle Tighteners**



**Single Adjusting Tighteners**



**Keystock**



**V-Belt Sheave Idlers**



**Flat Face Idlers**

For additional product information, visit [www.regalrexnord.com/Browning](http://www.regalrexnord.com/Browning)

# DRIVE TIGHTENERS

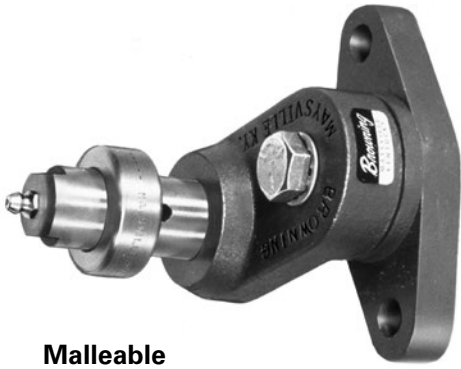

Malleable

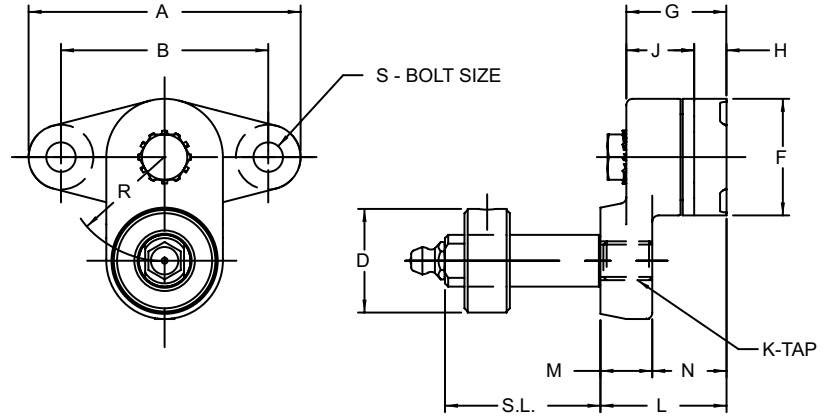

**Table No.1 Adjusting Tighteners**

Part No.	Shaft	DIMENSIONS (in.)															Wt. Lbs.
		A	B▲	D	F	G	H	J	K	L	M	N	R	S▲	S.L.		
ATN1	N1①	2 5/8	2	.500	1 1/8	15/16	5/16	5/8	3/8 - 16	1 3/16	1/2	11/16	1	1/4	1 1/2	.5	
ATH	None②	4 1/2	3 1/2	-	2	1 11/16	5/8	1 1/16	1/2 - 13	2 1/16	7/8	1 3/16	2	3/8	-	2.8	
ATP	None②	4 1/2	3 1/2	-	2	1 11/16	5/8	1 1/16	5/8 - 11	2 1/16	7/8	1 3/16	2	3/8	-	2.7	
ATQ	None②	4 1/2	3 1/2	-	2	1 11/16	5/8	1 1/16	3/4 - 10	2 1/16	7/8	1 3/16	2	3/8	-	2.6	
ATQ	N2③	4 1/2	3 1/2	1.000	2	1 11/16	5/8	1 1/16	3/4 - 10	2 1/16	7/8	1 3/16	2	3/8	2 1/8	3.5	
ATQ	N3③	4 1/2	3 1/2	1.000	2	1 11/16	5/8	1 1/16	3/4 - 10	2 1/16	7/8	1 3/16	2	3/8	3 1/8	3.7	
ATQ	N4③	4 1/2	3 1/2	1.000	2	1 11/16	5/8	1 1/16	3/4 - 10	2 1/16	7/8	1 3/16	2	3/8	4 1/8	4.0	
ATQ-1	None②	6 3/4	5 1/4	-	3	2 3/8	1 3/16	1 9/16	1 - 8	2 15/16	1 5/16	1 5/8	5	5/8	-	9.8	
ATQ-1	N5③	6 3/4	5 1/4	1.500	3	2 3/8	1 3/16	1 9/16	1 - 8	2 15/16	1 5/16	1 5/8	5	5/8	4	12.3	
ATQ-1	N6③	6 3/4	5 1/4	1.500	3	2 3/8	1 3/16	1 9/16	1 - 8	2 15/16	1 5/16	1 5/8	5	5/8	6	13.3	

▲ Holes are cast, some variations may be expected.

① Shaft is included.

② No shaft is required when used with Idler Bushings shown on page 159.

③ Shaft must be ordered separately.

## Type-1 Steel

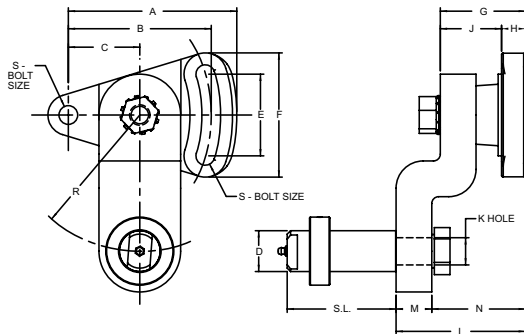

## Type-2 Ductile Iron

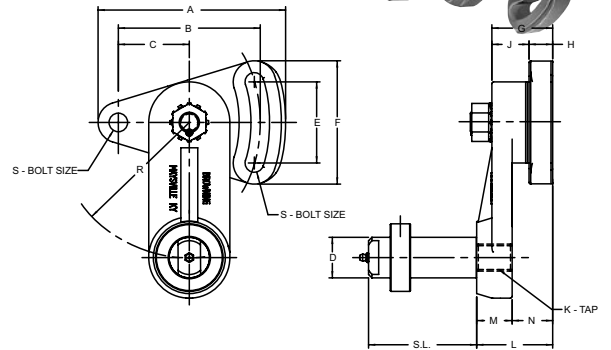

**Table No.2 Double Adjusting Tighteners**

Part No.	Type	Shaft	DIMENSIONS (in.)															Wt. Lbs.	
			A	B▲	C	D	E	F	G	H	J	K	L	M	N	R	S▲		S.L.
DATN1	2	N1①	2 23/32	2	15/16	.500	1 1/4	1 31/32	15/16	3/8	9/16	3/8 - 16	1 3/16	1 1/2	11/16	1	1/4	1/4	.7
DATSH	1	None②	4 5/8	3 1/2	1 3/4	-	2 1/16	3 1/4	1 5/16	3/8	15/16	9/16 Dia.	2 1/16	3/8	1 11/16	2	3/8	3/8	2.8
DATSP	1	None②	4 5/8	3 1/2	1 3/4	-	2 1/16	3 1/4	1 5/16	3/8	15/16	11/16 Dia.	2 1/16	3/8	1 11/16	2	3/8	3/8	2.8
DATSQ	1	None②	4 5/8	3 1/2	1 3/4	-	2 1/16	3 1/4	1 5/16	3/8	15/16	25/32 Dia.	2 1/16	3/8	1 11/16	2	3/8	3/8	2.7
DATSQ	1	N2③	4 5/8	3 1/2	1 3/4	1.000	2 1/16	3 1/4	1 5/16	3/8	15/16	25/32 Dia.	2 1/16	3/8	1 11/16	2	3/8	3/8	3.4
DATSQ	1	N3③	4 5/8	3 1/2	1 3/4	1.000	2 1/16	3 1/4	1 5/16	3/8	15/16	25/32 Dia.	2 1/16	3/8	1 11/16	2	3/8	3/8	3.8
DATSQ	1	N4③	4 5/8	3 1/2	1 3/4	1.000	2 1/16	3 1/4	1 5/16	3/8	15/16	25/32 Dia.	2 1/16	3/8	1 11/16	2	3/8	3/8	4.0
DATQ-1	2	None②	6 15/16	5 1/4	2 5/8	-	3	4 9/16	2 3/8	7/8	1 1/2	1 - 8	2 15/16	1 5/16	1 5/8	5	5/8	5/8	11.3
DATQ-1	2	N5③	6 15/16	5 1/4	2 5/8	1.500	3	4 9/16	2 3/8	7/8	1 1/2	1 - 8	2 15/16	1 5/16	1 5/8	5	5/8	5/8	13.6
DATQ-1	2	N6③	6 15/16	5 1/4	2 5/8	1.500	3	4 9/16	2 3/8	7/8	1 1/2	1 - 8	2 15/16	1 5/16	1 5/8	5	5/8	5/8	14.9

▲ Holes are cast, some variations may be expected.

① Shaft is included.

② No shaft is required when used with Idler Bushings shown on page 159.

③ SHAFT MUST BE ORDERED SEPARATELY.

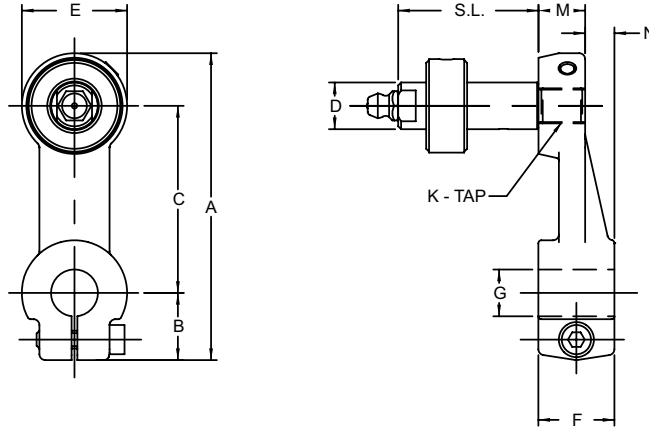

Ductile Iron



**Table No.1 Single Adjustable Tighteners**

Part No.	Shaft	DIMENSIONS (in.)												Wt. Lbs.
		A	B	C	D	E	F	G	K	M	N	S.L.		
SATN1	N1 <sup>①</sup>	3 9/32	23/32	2	.500	1 1/8	13/16	1/2	3/8 - 16	1/2	5/16	1 1/2		.8
SATH	None <sup>②</sup>	6 1/4	1 1/4	4	-	2	1 5/8	1	1/2 - 13	7/8	3/4	-	2.4	
SATP	None <sup>②</sup>	6 1/4	1 1/4	4	-	2	1 5/8	1	5/8 - 11	7/8	3/4	-	2.3	
SATQ	None <sup>②</sup>	6 1/4	1 1/4	4	-	2	1 5/8	1	3/4 - 10	7/8	3/4	-	2.3	
SATQ	N2 <sup>③</sup>	6 1/4	1 1/4	4	1.000	2	1 5/8	1	3/4 - 10	7/8	3/4	2 1/8	2.9	
SATQ	N3 <sup>③</sup>	6 1/4	1 1/4	4	1.000	2	1 5/8	1	3/4 - 10	7/8	3/4	3 1/8	3.1	
SATQ	N4 <sup>③</sup>	6 1/4	1 1/4	4	1.000	2	1 5/8	1	3/4 - 10	7/8	3/4	4 1/8	3.4	
SATQ-1	None <sup>②</sup>	9 3/8	1 7/8	6	-	3	2 7/16	1 1/2	1 - 8	1 5/16	1 1/8	-	8.0	
SATQ-1	N5 <sup>③</sup>	9 3/8	1 7/8	6	1.500	3	2 7/16	1 1/2	1 - 8	1 5/16	1 1/8	4	10.5	
SATQ-1	N6 <sup>③</sup>	9 3/8	1 7/8	6	1.500	3	2 7/16	1 1/2	1 - 8	1 5/16	1 1/8	6	11.5	

① Shaft is included.

② No shaft is required when used with Idler Bushings shown on page 159.

③ Shaft must be ordered separately.

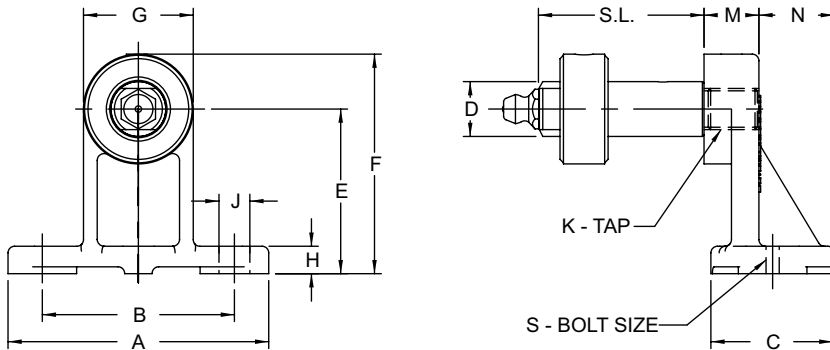

Ductile Iron



**Table No.2 Fixed Angle Tighteners**

Part No.	Shaft	DIMENSIONS (in.)														Wt. Lbs.
		A	B▲	C	D	E	F	G	H	J▲	K	M	N	S.L.	S▲	
FATN1	N1 <sup>①</sup>	2 3/8	1 3/4	1 1/8	.500	1 1/2	2	1	1/4	9/32	3/8 - 16	1/2	11/16	1 1/2	1/4	.4
FATH	None <sup>②</sup>	4	3	2	-	3	3 7/8	1 3/4	1/2	9/16	1/2 - 13	7/8	1 3/16	-	3/8	1.6
FATP	None <sup>②</sup>	4	3	2	-	3	3 7/8	1 3/4	1/2	9/16	5/8 - 11	7/8	1 3/16	-	3/8	1.5
FATQ	None <sup>②</sup>	4	3	2	-	3	3 7/8	1 3/4	1/2	9/16	3/4 - 10	7/8	1 3/16	-	3/8	1.4
FATQ	N2 <sup>③</sup>	4	3	2	1.000	3	3 7/8	1 3/4	1/2	9/16	3/4 - 10	7/8	1 3/16	2 1/8	3/8	2.5
FATQ	N3 <sup>③</sup>	4	3	2	1.000	3	3 7/8	1 3/4	1/2	9/16	3/4 - 10	7/8	1 3/16	3 1/8	3/8	2.6
FATQ	N4 <sup>③</sup>	4	3	2	1.000	3	3 7/8	1 3/4	1/2	9/16	3/4 - 10	7/8	1 3/16	4 1/8	3/8	3.0
FATQ-1	None <sup>②</sup>	7 1/2	6	3 1/2	-	6	7 5/16	2 5/8	3/4	15/16	1 - 8	1 5/16	2 1/4	-	5/8	8.1
FATQ-1	N5 <sup>③</sup>	7 1/2	6	3 1/2	1.500	6	7 5/16	2 5/8	3/4	15/16	1 - 8	1 5/16	2 1/4	4	5/8	10.6
FATQ-1	N6 <sup>③</sup>	7 1/2	6	3 1/2	1.500	6	7 5/16	2 5/8	3/4	15/16	1 - 8	1 5/16	2 1/4	6	5/8	11.5

▲ Holes are cast, some variations may be expected.

① Shaft is included.

② No shaft is required when used with Idler Bushings shown on page 159.

③ SHAFT MUST BE ORDERED SEPARATELY.

# DRIVE TIGHTENERS

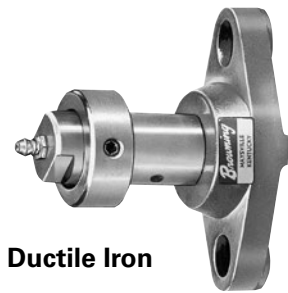

Ductile Iron

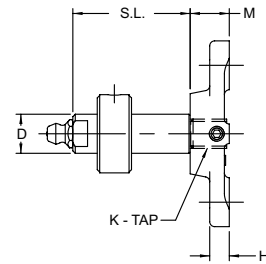
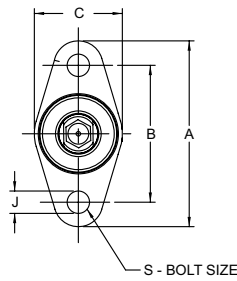

**Table No.1 Fixed Flange Tighteners**

Part No.	Shaft	DIMENSIONS (in.)											Wt. Lbs.
		A	B▲	C	D	H	J▲	K	M	S.L.	* S▲		
FFTN1	N1①	2 3/8	1 3/4	1 1/8	.500	1/4	9/32	3/8 - 16	1/2	1 1/2	1/4	.3	
FFTH	None②	4	3	2	-	1/2	9/16	1/2 - 13	15/16	-	3/8	.9	
FFTP	None②	4	3	2	-	1/2	9/16	5/8 - 11	15/16	-	3/8	.9	
FFTQ	None②	4	3	2	-	1/2	9/16	3/4 - 10	15/16	-	3/8	.8	
FFTQ	N2③	4	3	2	1.000	1/2	9/16	3/4 - 10	15/16	2 1/8	3/8	1.6	
FFTQ	N3③	4	3	2	1.000	1/2	9/16	3/4 - 10	15/16	3 1/8	3/8	1.8	
FFTQ	N4③	4	3	2	1.000	1/2	9/16	3/4 - 10	15/16	4 1/8	3/8	2.1	
FFTQ-1	None②	7 1/2	6	3 1/2	-	3/4	15/16	1 - 8	1 7/16	-	5/8	4.8	
FFTQ-1	N5③	7 1/2	6	3 1/2	1.500	3/4	15/16	1 - 8	1 7/16	4	5/8	7.3	
FFTQ-1	N6③	7 1/2	6	3 1/2	1.500	3/4	15/16	1 - 8	1 7/16	6	5/8	8.5	

▲ Holes are cast, some variations may be expected.

① Shaft is included.

② No shaft is required when used with Idler Bushings shown on page 159.

③ Shaft must be ordered separately.

**Table No.2 Tighteners Shafts**

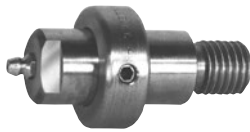

Part No.	DIMENSIONS (in.)						Wt. Lbs.
	O.L.	D	K	T	S.L.		
N1	2 5/16	.500	3/8 - 16	7/16	1 1/2	.13	
N2	3 3/8	1.000	3/4 - 10	7/8	2 1/8	.6	
N3	4 3/8	1.000	3/4 - 10	7/8	3 1/8	.9	
N4	5 1/8	1.000	3/4 - 10	7/8	4 1/8	1.0	
N5	5 11/16	1.500	1 - 8	1 5/16	4	2.8	
N6	7 11/16	1.500	1 - 8	1 5/16	6	3.8	



**Table No.3 Flat Face Idlers**

Part No.	Type	Shaft Length (in.)	DIMENSIONS (in.)										Wt. Lbs.	Radial Load Capacity in Pounds Based on 2500 Hours Average Life at rpm Shown ■							
			O.D.	D	B	H	W	F	L	P	C	100		500	1000	1500	2000	2500	3000	3500	
N1D05F	1	1 1/2*	1 3/4	1 3/8	1/2	1 1/4	3/4	9/16	3/4	1/8	1/8	.3	665	406	331	294	269	250	237	226	
N4D1F	1	2 1/8*	4 3/8	4	1	1 7/8	1 7/16	1 1/16	1 1/4	1/8	5/16	3.0	2927	1787	1458	1295	1185	1104	1047	997	
N4D2F	1	3 1/8*	4 3/8	4	1	1 7/8	2 7/16	2 1/16	2 1/2	1/8	1/16	5.0	4348	2654	2166	1922	1760	1640	1544	1482	
N4D3F	1	4 1/8*	4 3/8	4	1	1 7/8	3 7/16	3 1/16	3 1/2	1/8	1/16	7.8	5854	3574	2916	2590	2370	2208	2094	1994	
N4D4F	1	6*	7	4	1 1/2	2 5/8	5	4 1/2	4	1/8	1 1/8	22.5	5884	3592	2930	2602	2380	2218	2102	2004	
N4D6F	1	6*	7	4	1 1/2	2 5/8	6 3/4	6 1/4	5	1/8	1 7/8	29.5	5884	3592	2930	2602	2380	2218	2102	2004	
4D1FH	2	H1▲	4 3/8	4	▲	-	1 7/16	1 1/16	7/8	-	9/16	3.4	1518	1016	854	772	718	678	648	624	
4D2FP	2	P1▲	4 3/8	4	▲	-	2 7/16	2 1/16	1 5/16	-	1 1/8	4.6	1518	1016	854	772	718	678	648	624	
4D3FP	2	P1▲	4 3/8	4	▲	-	3 7/16	3 1/16	1 5/16	-	2 1/8	5.6	1518	1016	854	772	718	678	648	624	



**Table No.4 V-Belt Sheave Idlers**

Part No.	Shaft Length (in.)	Belt Size	DIMENSIONS (in.)		Wt. Lbs.	Radial Load Capacity in Pounds Based on 2500 Hours Average Life at rpm Shown ■							
			O.D.	Wt. Lbs.		100	500	1000	1500	2000	2500	3000	3500
NOK17	1 1/2	3L	1.92	.1	665	406	331	294	269	250	237	226	
NAK25	1 1/2	4L or A	2.50	.3	665	406	331	294	269	250	237	226	
NAK30	1 1/2	4L or A	3.05	.5	665	406	331	294	269	250	237	226	
NAK41	2 1/8	4L or A	3.95	1.0	2174	1327	1083	961	880	820	772	741	
NBK40	2 1/8	5L or B	3.96	1.1	2174	1327	1083	961	880	820	772	741	
NBK52	2 1/8	5L or B	4.96	1.6	2174	1327	1083	961	880	820	772	741	

\*For use with Drive Tighteners shown on pages 155 and 156 and above with shaft lengths indicated.

▲ For use with H-1 1/2 or P1-5/8 IDLER BUSHINGS shown on page 159.

■ See page 168 for factors to use for Average Life of more or less than 2500 hours.

All Browning® Stock Idlers furnished with needle bearings have retainers that ensure minimum internal friction and wear by separating the needle rollers. These bearings are inset approximately 1/8" on either end of the Idler hubs to form a grease cavity.

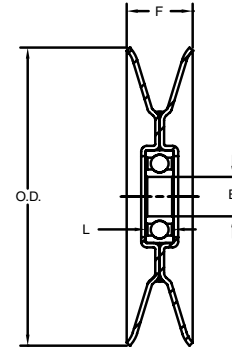

### Features and Benefits

- Riveted Steel Idler for drop-in replacement of OEM parts
- Riveted Seam for maximum strength
- Sealed for Life Ball Bearing
- Available from Stock
- Available in Clear Pak package –or- standard carton

Table No.1

PART No.	DIMENSIONS				LBS. WEIGHT	MATERIALS
	O.D.	*BELT SIZE	B	F		
IDLER SHEAVE BOXED	5.0	4L, 5L, A, B, AX, BX	.375(9.525MM)	1.4	1.3	STEEL
IDLER SHEAVE CLEAR PK	5.0	4L, 5L, A, B, AX, BX	.375(9.525MM)	1.4	1.3	

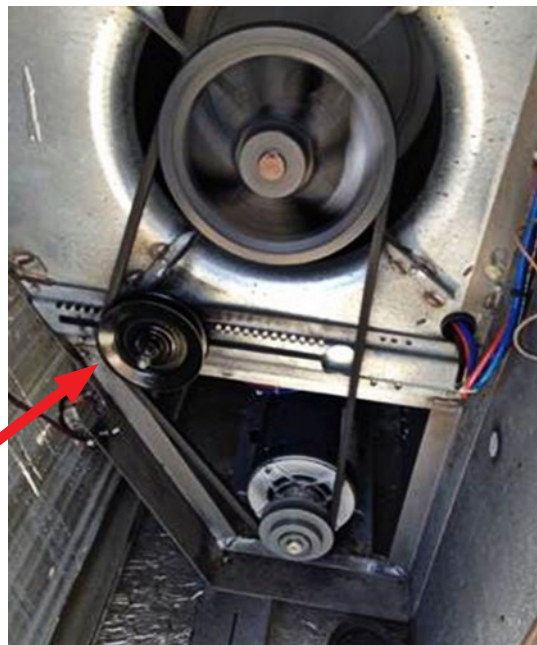

Drop-in replacement of OEM parts.

## Idler Bushings

Browning® Idler Bushings provides the "Idler" componentry in the following parts:

Sheaves  
 FHP  
 Multiple  
 358

Gearbelt® Pulleys  
 Gears  
 Hardened and Standard Sprockets

Furnished complete with:  
 Ball bearings, cap screws, stud bolts and nuts

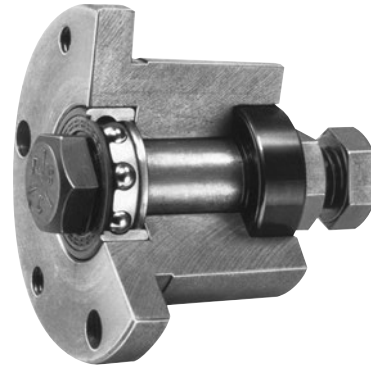

Available for H, P1, Q1 and R1 bore items.

**Table No.1 Specifications**

Part No.	DIMENSIONS (in.)		Tapped Holes		Approx. Wt. Lbs
	O.D.	O.L.	No.	Size (in.)	
*IDH1 - 1/2	2 1/2	2 9/16	2	1-4 - 20	.9
*IDP1 - 5/8	3	3 41/64	2	5/16 - 18	1.9
*IDQ1 - 3/4	4 1/8	4 7/32	2	3/8 - 16	5.5
*IDQ1 - 1	4 1/8	4 39/64	2	3/8 - 16	5.9
*IDR1 - 1 1/2	5 3/8	6 1/2	2	3/8 - 16	14.1

\* These sizes fit H, P, Q and Q1 Drive Tighteners shown on pages 155-157.  
 Note : Mount stud bolt in either direction.

**Table No.2 Load Ratings - Idler Bushings**

Part No.	Radial Load Capacity in Pounds Based on 2500 Hrs average Life at rpm Shown							
	100	500	1000	1500	2000	2500	3000	3500
IDH1 - 1/2	1518	1016	854	772	718	678	648	624
IDP1 - 5/8	1518	1016	854	772	718	678	648	624
IDQ1 - 3/4	3320	2222	1868	1688	1568	1486	1420	1366
IDQ1 - 1	3554	2378	2000	1806	1680	1590	1518	1462
IDR1 - 1 1/2	8326	5570	4684	4232	3936	3726	3560	3424

### Average Life Factors

Radial load capacities shown for Needle Bearing Idlers and Idler Bushings are based on 2500 hours average life. If another average life is desired, these ratings must be modified by factors as follows:

500 Hours - 1.71	4000 Hours - .85	9000 Hours - .65
1000 Hours - 1.36	5000 Hours - .79	10000 Hours - .63
1500 Hours - 1.19	6000 Hours - .75	15000 Hours - .55
2000 Hours - 1.07	7000 Hours - .71	20000 Hours - .50
3000 Hours - .94	8000 Hours - .68	

## Browning Drive Tighteners and Idlers

Correct operating tension is an important factor in the satisfactory performance and life of any V-belt or chain drive. As V-belts wear they seat themselves deeper in the sheave grooves. This sealing, along with belt stretch, lessens the initial tension. The result is slippage and loss in horsepower capacity unless some form of take-up is used to restore and maintain original tension.

As chains wear they elongate, which results in sway or slop and increased vibration. This puts undue shock into the drive and increases bearing wear.

Both V-belt and chain drives wear at an increased rate if allowed to run with insufficient tension. Adjustment of center distance is the best method of maintaining proper tension. In cases of fixed centers, Browning Drive Tighteners and Idlers provide the necessary means of take-up. The Browning Drive Tighteners also provide a means of obtaining extra belt or chain wrap frequently needed for extremely high ratios, multiple shaft or serpentine drives.

Careful consideration must be given to the following when using idlers:

1. Too much tension in a drive causes excessive belt, chain and bearing wear.
2. Too little tension in a drive allows belt slippage or chain vibration, resulting in loss of power and additional wear.
3. All idlers should be used on the slack side of the drive.
4. V-belt drive idlers should be used on the inside of the belt. Allowance should be made for horsepower loss due to the reduced arc of contact.
5. Where necessary to use V-belt drive idlers on the outside of the belt, the reverse bending will reduce belt life.
6. Flat face pulley idlers can be used on either inside or outside of the belt.
7. Sprocket idlers should be used on the outside of chain drives and with at least three teeth engaged in the chain.
8. Idlers used on the inside of a drive should be located approximately 1/2 of the center distance from the large sheave, pulley or sprocket.
9. Idlers used on the outside of a drive should be located approximately 1/2 of the center distance from the small sheave, pulley or sprocket.

## KEYS AND KEYSTOCK

**Table No.1 Standard Keyseats (in.)**

Old Standard Keyseats		New Standard Keyseats	
Bore Range	Keyseat	Bore Range	Keyseat
1/2 - 9/16	1/8 x 1/16	1/2 - 9/16	1/8 x 1/16
5/8 - 7/8	3/16 x 3/32	5/8 - 7/8	3/16 x 3/32
15/16 - 1 5/16	1/4 x 1/8	15/16 - 1 1/4	1/4 x 1/8
1 3/8 - 1 13/16	3/8 x 3/16	1 5/16 - 1 3/8	5/16 x 5/32
1 7/8 - 2 1/4	1/2 x 1/4	1 7/16 - 1 3/4	3/8 x 3/16
2 5/16 - 2 13/16	5/8 x 5/16	1 13/16 - 2 1/4	1/2 x 1/4
2 7/8 - 2 13/16	3/4 x 3/8	2 5/16 - 2 3/4	5/8 x 5/16
3 7/8 - 4 11/16	1 x 1/2	2 13/16 - 3 1/4	3/4 x 3/8
4 3/4 - 5 11/16	1 1/4 x 5/8	3 5/16 - 3 3/4	7/8 x 7/16
5 3/4 - 6 15/16	1 1/2 x 3/4	3 13/16 - 4 1/2	1 x 1/2
7 - 7 15/16	1 3/4 x 7/8	4 9/16 - 5 1/2	1 1/4 x 5/8
		5 9/16 - 6 1/2	1 1/2 x 3/4
		6 9/16 - 7 1/2	1 3/4 x 5/8
		7 9/16 - 8	2 x 11/16

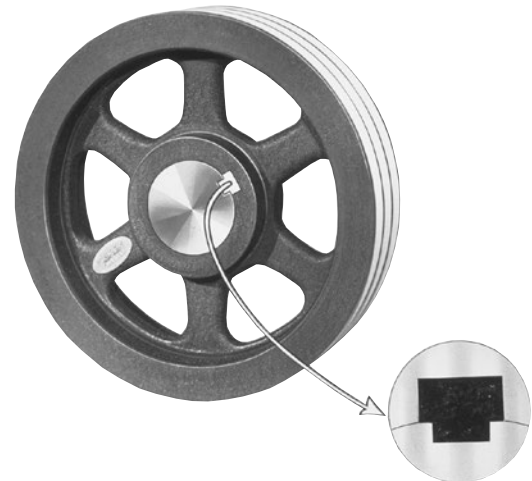

**Table No.2 Square and Rectangular Keys**

Single Keys		24* Lengths		Dimensions (in.)	
Part No.	*Max Length (in.)	Part No.	Weight Lbs.	A	B
K-24	3	S-24	.13	1/8	1/8
K-25	3	S-25	.25	3/16	3/16
K-26	5	R-26	.31	1/4	3/16
K-27	5	S-27	.44	1/4	1/4
K-99	5	S-99	.63	5/16	5/16
K-28	5	R-28	.75	3/8	5/16
K-29	5	S-29	.88	3/8	3/8
K-41	7	S-41	1.0	7/16	7/16
K-30	7	R-30	1.4	1/2	7/16
K-31	7	S-31	1.5	1/2	1/2
K-39	7	S-39	2.0	9/16	9/16
K-37	7	S-37	2.6	5/8	5/8
K-38	9	S-38	3.0	11/16	11/16
K-32	12	R-32	3.0	3/4	1/2
K-33	12	R-33	3.1	3/4	5/8
K-34	12	S-37	3.6	3/4	3/4
K-40	12	S-40	5.1	7/8	7/8
K-35	12	R-35	4.9	1	3/4
K-36	12	S-36	6.5	1	1

\* Single keys will be cut to desired length up to maximum length shown. When longer keys are specified we will furnish 24\* lengths.

For use with anything which keys to the shaft:

- Sheaves
- Pulleys
- Couplings
- Sprockets
- Gears

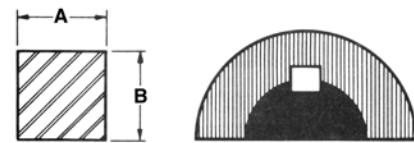

Square

**Table No.3 Offset Keys**

Single Keys		24* Lengths		Dimensions (in.)			
Part No.	*Max Length (in.)	Part No.	Weight Lbs.	A	B	C	D
K-1	3	O-1	.13	3/16	3/32	1/8	1/16
K-2	3	O-2	.25	3/16	3/32	1/4	3/32
K-3	5	O-3	.31	3/16	3/32	1/4	1/8
K-4	5	O-4	.44	1/4	1/8	5/16	1/8
K-5	5	O-5	.50	1/4	1/8	3/8	1/8
K-6	5	O-6	.63	1/4	1/8	3/8	3/16
K-7	5	O-7	.69	3/8	3/16	5/16	1/8
K-51	5	O-51	.75	3/8	3/16	5/16	5/32
K-8	5	O-8	.88	3/8	3/16	7/16	5/32
K-9	5	O-9	.81	3/8	3/16	1/2	3/16
K-10	5	O-10	1.3	3/8	3/16	1/2	1/4
K-11	7	O-11	1.3	1/2	1/4	7/16	5/32
K-12	7	O-12	1.5	1/2	1/4	9/16	3/16
K-13	7	O-13	1.5	1/2	1/4	5/8	3/16
K-14	7	O-14	2.0	1/2	1/4	5/8	5/16
K-15	7	O-15	2.0	1/2	1/4	11/16	1/4
K-100	9	O-100	1.8	5/8	5/16	5/8	3/16
K-16	9	O-16	2.4	5/8	5/16	11/16	1/4
K-101	12	O-101	2.6	3/4	3/8	1/2	1/4
K-17	12	O-17	2.6	3/4	3/8	5/8	3/16
K-18	12	O-18	3.2	3/4	3/8	5/8	5/16
K-19	12	O-19	3.0	3/4	3/8	11/16	1/4
K-20	12	O-20	3.4	3/4	3/8	13/16	9/32
K-21	12	O-21	4.4	3/4	3/8	7/8	7/16
K-22	12	O-22	3.8	3/4	3/8	15/16	5/16
K-23	12	O-23	5.8	3/4	3/8	1	1/2
K-410	12	O-410	5.8	1	1/2	7/8	7/16

\* Single keys will be cut to desired length up to maximum length shown. When longer keys are specified we will furnish 24\* lengths.

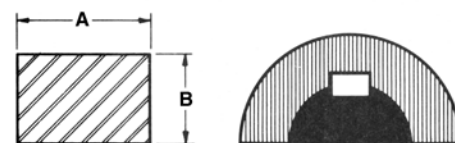

Rectangular

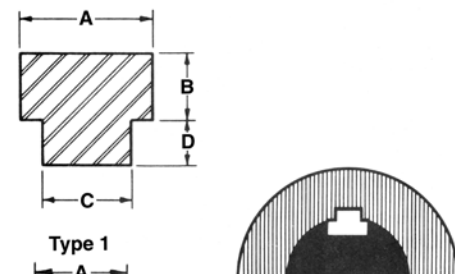

Offset

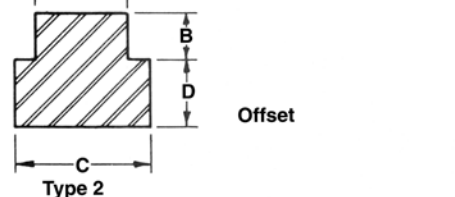

Type 2

# V-BELT ACCESSORIES

## GROOVE GAUGE

Multi-tabbed plastic tool designed to help determine groove wear of sheaves.

Part Number	Weight
<b>Groove Gauge</b>	2.0

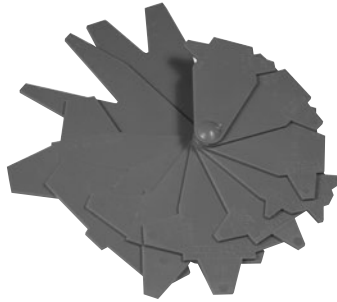

## V-BELT TENSION CHECKER

Indicates tension on all V-belt drives (3L, 4L, 5L, A, B, C, D, 3V, 5V and 8V). Compact, spring-loaded design. Easy to operate; instructions included. Adjustable for 10" to 170" belt span and up to 35 pounds of tension.

Note: proper tensioning is necessary to avoid premature belt wear.

Part Number	Weight
<b>Belt Tension Checker</b>	2.0

## V-BELT RULE

Used to measure length of all sizes of V-belts (3L, 4L, 5L, A, B, 3V and 5V). Manufactured from durable aluminum. Wall mounting holes provided. Easily identifies V-belt length up to 100".

Part Number	Weight
<b>3839 Belt Rule</b>	2.0

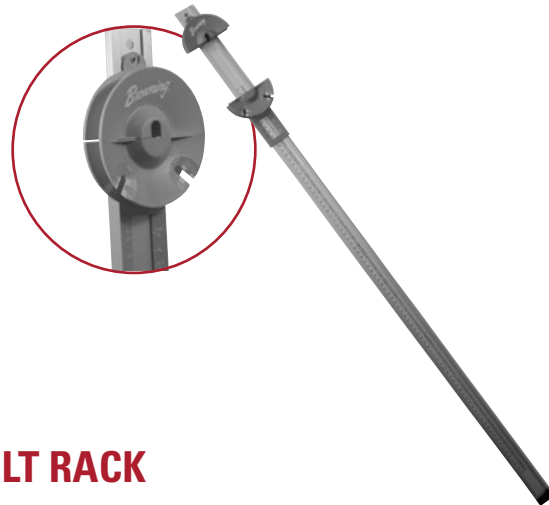

## V-BELT RACK

36" long rack with eight 6" hooks provided. Mounting holes provided for easy wall mounting. Order V-belts separately.

Part Number	Weight
<b>Belt Rack</b>	2.0
<b>12IN BELT DISPLAY HOOK</b> *Min Order Qty 10	.010 EA



# BROWNING® TENSO-SET® SELF-TENSIONING MOTOR BASE

The new Browning Tenso-Set Series 600 horizontal sliding motor base with optional Quick Release (QR) is an industry first for v-belt drives. When compared to traditional pan or open frame bases, the Tenso-Set QR design enhances technician convenience and belt drive efficiency by automatically maintaining belt tension for extended periods and allowing quick belt changes in just minutes.

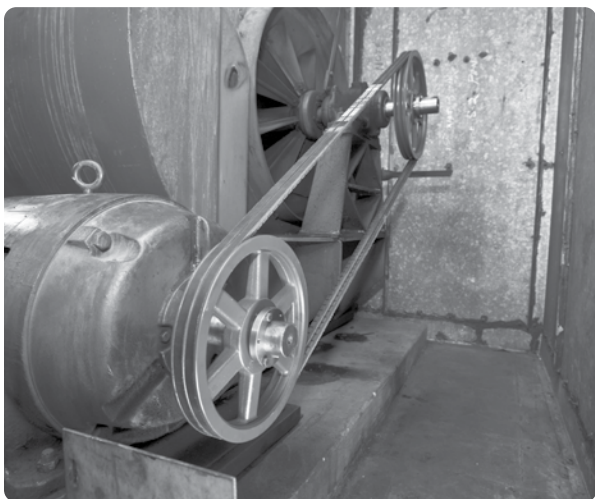

*Browning Optimized 2 groove 5VX Solution*

## **BENEFITS COMPARED TO PAN OR OPEN FACE MOTOR BASES**

- Significantly reduces time required to change v-belts
- Promotes greater efficiency by constantly maintaining v-belt tension
- Tube rail and one-piece carriage design promotes and maintains superior drive alignment
- Improved safety. No need to cut off belts or roll them onto sheaves
- Improves belt life by helping to eliminate slipping

## **TENSO SET®**

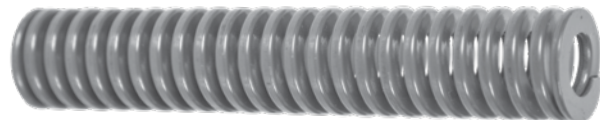

*Constant spring tension automatically compensates for belt wear and reduces frequency of belt adjustments*

# TENSO-SET® SERIES 600 AUTO-TENSIONING MOTOR BASE

Quick Release Functionality:

1. Closed latch and operating position
2. De-tensioned drive allows release lever gate to slide open
3. Motor carriage slides forward and tensioning bolt passes through frame, allowing a significant reduction in time compared to pan and open face motor bases. This allows for efficient maintenance.

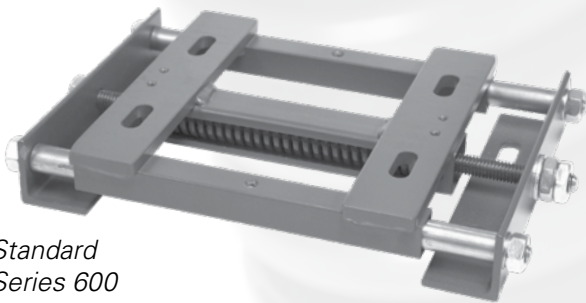

Standard  
Series 600



With Quick  
Release (QR)

NEMA BASE - SELF-ADJUSTING			
PART DESCRIPTION	BASE NUMBER	NEMA FRAME	HP RANGE
BSAMBN601	601	48 - 56	1/4 - 2
BSAMBN605	605	143 - 145	1 - 2
BSAMBN607	607	182 - 184	3 - 5
BSAMBN613	613	213 - 215	7 1/2 - 10
BSAMBN621	621	254 - 256	15 - 20
BSAMBN623	623	284 - 286	25 - 30
BSAMBN925	DX925	324 - 326	40 - 50
BSAMBN927	DX927	364 - 365	60 - 75
BSAMBN929	DX929	404 - 405	75 - 100
BSAMBN931	DX931	444 - 445	100 - 150
BSAMBN933	DX933	447	200 - 250

NEMA BASE - QUICK RELEASE SELF-ADJUSTING			
PART DESCRIPTION	BASE NUMBER	NEMA FRAME	HP RANGE
BSAMBN601QR	601	48 - 56	1/4 - 2
BSAMBN605QR	605	143 - 145	1 - 2
BSAMBN607QR	607	182 - 184	3 - 5
BSAMBN613QR	613	213 - 215	7 1/2 - 10
BSAMBN621QR	621	254 - 256	15 - 20
BSAMBN623QR	623	284 - 286	25 - 30

IEC BASE - SELF-ADJUSTING			
PART DESCRIPTION	BASE NUMBER	IEC FRAME	KW RANGE
BSAMBI605	605	90S - 90L	.75 - 2.2
BSAMBI607	607	112S - 112M	1.5 - 4
BSAMBI613	613	132S - 132M	5.5 - 7.5
BSAMBI621	621	160M - 160L	11.0 - 15.0
BSAMBI623	623	180M - 180L	18.5 - 22
BSAMBI925	DX925	200M - 200L	30 - 37
BSAMBI927	DX927	225S - 225M	37 - 45
BSAMBI929	DX929	250S - 250M	55 - 75
BSAMBI931	DX931	280S - 280M	75 - 110

NOTE: Motor bases for IEC 601 or 933 are not available.

IEC BASE - QUICK RELEASE SELF-ADJUSTING			
PART DESCRIPTION	BASE NUMBER	IEC FRAME	KW RANGE
BSAMBI605QR	605	90S - 90L	.75 - 2.2
BSAMBI607QR	607	112S - 112M	1.5 - 4
BSAMBI613QR	613	132S - 132M	5.5 - 7.5
BSAMBI621QR	621	160M - 160L	11.0 - 15.0
BSAMBI623QR	623	180M - 180L	18.5 - 22

## TROUBLESHOOTING GUIDE FOR BROWNING® V-BELT DRIVES

What Happened	Probable Cause	What To Do
<b>Belt stretched beyond takeup</b>	Worn sheaves.	Replace sheaves.
	Underdesigned drive.	Redesign and replace drive.
	Takeup slipped.	Reposition takeup.
	Drive excessively tensioned.	Properly tension drive.
	Damaged cord section during installation.	Replace belt and properly install.
<b>Excessive vibration</b>	Damaged belt cord section.	Replace belt.
	Loose belt.	Tension belt.
	Belts improperly tensioned.	Tension drive with slack of each belt on the same side of the drive.
<b>Belt too long at installation</b>	Insufficient takeup.	Use shorter belts.
	Drive improperly set up.	Recheck driver and driven machine setup.
	Wrong size belt.	Use correct size belt.
<b>Belt too short at installation</b>	Insufficient takeup.	Use longer belts.
	Drive improperly set up.	Recheck driver and driven machine setup.
	Wrong size belt.	Use correct size belt.
<b>Belts mismatched at installation</b>	Belts matched by code number only.	Replace belts with Browning machine matched belts.
	Old belts and new belts used together on same drive.	Replace with new belts.
	Different brand name belts used together on same drive.	Replace with a set of Browning machine matched belts.
	Driver and driven shafts are not parallel.	Realign drives.
	Worn sheaves.	Replace sheaves.
<b>Belts mismatched after service</b>	Belts improperly tensioned, causing more stretch of some belts than others.	Replace belts and tension drive with slack of each belt on the same side of the drive.
	Old belts and new belts used together on same drive.	Replace with new belts.
	Different brand name belts used on same drive.	Replace with a set of Browning machine matched belts.
	Driver and driven shafts shifted from parallel.	Realign drives.
	Belt cord section damaged during installation.	Replace belts and install properly.

## TROUBLESHOOTING GUIDE FOR BROWNING® V-BELT DRIVES

What Happened	Probable Cause	What To Do
<b>Short belt life</b>	Spin burns from belt slipping on driver sheave under stalled load conditions or when starting.	Tension belt.
	Gouges or extreme cover wear caused by belt rubbing on drive guards or other objects.	Eliminate obstruction or realign drive to provide clearance.
	High ambient temperature.	Use Gripnotch belts. Provide ventilation. Shield belt.
	Grease or oil on belt.	Check for leaky bearings. Clean belt and sheaves.
	Underdesigned drive.	Redesign drive.
	Worn sheaves.	Replace sheaves.
<b>Belts turn over in groove</b>	Damaged cord section in belts. Frayed or gouged belts.	Replace belts.
	Excessive vibration.	Tension belts. Replace belts if damaged. Use banded belts.
	Flat idler pulley misaligned.	Realign idler.
	Worn sheaves.	Replace sheaves.
	Sheave misalignment.	Realign drive.
<b>Belt squeal</b>	High starting load. Belt not tensioned properly. Excessive overload.	Tension drive or redesign and replace drive.
	Insufficient arc of contact.	Increase center distance or use Gripnotch belts.
<b>Belt breakage</b>	Foreign material in drive.	Provide drive guard.
	Belt damaged during installation.	Follow Browning V-belt Drive Installation instructions.
	Shock or extreme overload.	Eliminate overload cause or redesign drive.

**⚠ WARNING** Indicates a hazard which, if not avoided, could result in serious injury or death.

- Disconnect and lock-out power before installation and maintenance. Working on or near energized equipment can result in severe injury or death.
- Do not operate equipment without guards in place. Exposed equipment can result in severe injury or death.
- Read and follow all instructions carefully.

## TROUBLESHOOTING GUIDE FOR BROWNING® MVP® VARIABLE SPEED BELT DRIVES

What Happened	Probable Cause	What To Do
<b>Short belt life</b>	Spin burns from belt slipping on driver sheave under stalled load conditions or when starting.	Tension belt.
	Gouges or extreme cover wear caused by belt rubbing on drive guards or other objects.	Eliminate obstruction or realign drive to provide clearance.
	High ambient temperature.	Provide ventilation. Shield belt. Use Gripnotch belts.
	Grease or oil on belt.	Check for leaky bearings. Clean belt and sheaves.
	Worn sheaves.	Replace sheaves.
	Misalignment	Use companion sheave and align with center grooves.
<b>Belts turn over in groove</b>	Damaged cord section in belts. Frayed or gouged belts.	Replace belts.
	Excessive vibration.	Tension belt. Replace belts if damaged.
	Flat idler pulley misaligned.	Realign idler.
	Worn sheaves.	Replace sheaves.
	Sheave misalignment.	Realign drive.
<b>Belt squeal</b>	High starting load. Belt not tensioned properly. Excessive overload.	Tension drive or redesign and replace drive.
	Insufficient arc of contact.	Increase center distance or use and replace drive.
<b>Belt breakage</b>	Foreign material in drive.	Provide drive guard.
	Belt damaged during installation.	Follow Browning V-belt Drive Installation instructions.
	Shock or extreme overload.	Eliminate overload cause or redesign drive.
<b>Belt stretch beyond takeup</b>	Worn sheaves.	Replace sheaves.
	Underdesigned drive.	Redesign and replace drive.
	Takeup slipped.	Reposition takeup.
	Drive excessively tensioned.	Properly tension drive.
	Damaged cord section during installation.	Replace belt and properly install.
<b>Excessive vibration</b>	Damaged cord section.	Replace belt.
	Loose belt.	Tension belt.
<b>Belt too long at installation</b>	Insufficient takeup.	Use shorter belt.
	Drive improperly setup.	Recheck driver and driven machine set up.
	Wrong sized belt.	Use correct size belt.
<b>Belt too short at installation</b>	Insufficient takeup.	Use longer belt.
	Drive improperly setup.	Recheck driver and driven machine set up.
	Wrong sized belt.	Use correct size belt.

## TROUBLESHOOTING GUIDE FOR BROWNING® MVP® VARIABLE SPEED BELT DRIVES

What Happened	Probable Cause	What To Do
<b>Belts mismatched at installation</b>	Belts matched by code number only.	Replace belts with Browning machine matched belts.
	Old belts and new belts used together on same drive.	Replace with new belts. Never mix old and new belts on the same drive.
	Different brand name belts used together on same drive.	Replace with a set of Browning machine matched belts.
	Driver and driven shafts not parallel.	Realign drive.
	Worn Sheaves	Replace sheaves.
<b>Belts mismatched after service</b>	Belts improperly tensioned, causing more stretch of some belts than others.	Replace belts and tension drive with slack of each belt on the same side of the drive.
	Old belts and new belts used together on same drive.	Replace with new belts. Never mix old and new belts on the same drive.
	Different brand name belts used on same drive.	Replace with a set of Browning machine matched belts.
	Driver and driven shafts shifted from parallel.	Realign drive.
	Belt cord section damaged during installation	Replace belts and install properly.
<b>Sheave fails to adjust</b>	Fretting corrosion (Drive allowed to operate at one speed over a period of time.)	Contact Regal Rexnord Services for proper inspection and corrective action
<b>Sheave flange breaks</b>	Misalignment (possible if a companion sheave is not used where required)	Replace sheave and align by the center grooves.

**⚠ WARNING** Indicates a hazard which, if not avoided, could result in serious injury or death.

- Disconnect and lock-out power before installation and maintenance. Working on or near energized equipment can result in severe injury or death.
- Do not operate equipment without guards in place. Exposed equipment can result in severe injury or death.
- Read and follow all instructions carefully.

## TROUBLESHOOTING GUIDE FOR BROWNING® MOUNTED BEARINGS

What Happened	Probable Cause	What To Do
<b>Noise (high pitch)</b>	Misalignment.	Correct alignment. Replace unit with a Browning self-aligning bearing.
<b>Noise (low pitch)</b>	Bearing brinelled.	Replace bearing.
<b>Noise (intermittent rumbles and rattles)</b>	Too much shaft to bearing bore clearance.	Use proper size shaft. Replace bearing with correct size unit.
	Dirt in bearing.	Purge bearing with grease. If necessary, replace unit.
	Loose machine parts	Tighten machine parts.
<b>Bearing gets excessively hot</b>	First start after relubrication (grease redistribution).	Allow machine parts to cool and restart.
	Over lubrication.	Use less lubricant.
	No lubricant.	Add lubricant.
	Excessive load.	Check bearing loads. Replace with a larger unit. If thrust load is caused by shaft expansion, an expansion type bearing should be used.
	Bearing located near a heat source.	Shield the bearing or move it away from the heat source.
	Bearing over misaligned.	Correct alignment.
	Excessive speed.	Check bearing ratings and speed limitations. Replace with a unit that is capable of high speed operation.
<b>Excessive vibration</b>	Unbalanced machine parts.	Balanced machine parts.
	Loose machine parts.	Check and tighten machine parts.
	Improper shaft to bearing bore fit.	Check shaft size. Replace unit with correct bearing.
	Bent shaft.	Straighten or replace shaft.
	Bearing brinelled.	Replace bearing.
<b>Shaft binds when rotated</b>	Bent shaft.	Straighten or replace shaft.
	Misalignment.	Correct alignment. Replace unit with a Browning self-aligning bearing.
	Dirt in bearing.	Purge bearing with grease. If necessary, replace unit.
	Rotate interference.	Check clearance of rotating parts.
<b>Wear of shaft steel</b>	Too much shaft to bearing bore clearance.	Correct shaft fit. Use new shaft.
	Poor shaft finish.	Use new shaft. Smooth turn grind shaft to next smaller standard bore and install new bearing.

## CORRECTIVE MAINTENANCE AND TROUBLESHOOTING OF V-BELT DRIVES

SYMPTOMS \ CAUSES	CAUSES																								
	Belts Pried On or Misplaced Slack	Belts Rubbing Guard	Sheaves Misaligned	Worn or Damaged Sheaves	Sheaves Too Far From Bearing	Poor Bearing or Shaft Condition	Insufficient Tension	Excessive Tension	Improper Sheave Installation	Belts Worn (Normal Service Life)	Wrong Belt Cross-Section or Type	Mismatched Belts or Mixed Brands	Machine-Induces Impulse or Shock	Improper or Prolonged Storage	Excessive Heat	Excessive Oil or Grease	Use of Belt Dressing	Abrasive Environment	Foreign Objects in Grooves	Excessive Moisture	Overloaded Drive Underbelting	Drive Seriously Overbelted	Sheaves Too Small	Insufficient Wrap on Small Sheave	Backside Idler
Rapid Sidewall Wear		●	●	*			●				●			●	●	●	●	●		●					
Worn Cover on Back	*																								●
Belt Turns Over Or Jumps Off Sheave	●						●			●		*							●						
Belt Soft, Swollen															*	●									
Belt Slips, Squeals (Spin Burn)				*			*			●						●				●	●		●		
Belt Cover Split	*																		●						
Underside Cracked			●											●	*								*		*
Tie-Band Damaged		●	●	*															*						
Repeated Breakage	●						●					●							●	*					
Belts Ride Too High											*						●								
Belts Bottoming				*					●	●															
Repeated Take-up Necessary				●			●			●											*				
Belts Vibrate Excessively or Appear Mismatched			●	●			●	●			●	*										●			
Bearing Are Hot				●	●	●	*							●								●	●		
Shafts Whip or Bend				●	●	●	*															●	●		
Cracked Bushings				●			*																		
Sheave Wobble				●		●	*																		

\* Indicates most common causes  
 ● Indicates other possible causes

### BROWNING® GROOVE AND V-BELT GAUGE

Quick and easy way to identify sheave groove and V-belt type. Assists in checking for worn grooves.



## A GUIDE TO NEMA®\* MOTOR FRAMES AND SHAFT DIMENSIONS

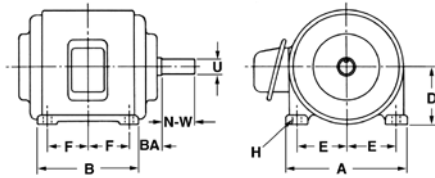

Motor ratings and dimensions shown in Table No. 1, below, are for general purpose motors as indicated. Frames for the 1952 - 1953 and the 1964 rerates are shown. All dimensions are subject to change without notice. Those shown are intended as a guide only. Certified dimension drawings from the motor manufacturer should be used.

**Table No.1 Specifications**

Frame No.	Dimensions (in.)									Keyseat		Key Length	hp for Various Motor rpm			
	A Max.	B Max.	D	E	F	H	BA	N-W	U	Width	Depth		3600	1800	1200	900

### Fractional Horsepower Motors

48	5 3/8	3 1/2	3	2 1/8	1 3/8	11/32▲	2 1/2	1 1/2	1/2	Flat	3/64	-	1/8-1/2	1/8-1/3	1/6	-
56	6.5	4.5	3.5	2 7/16	1 1/2	11/32▲	2.75	2 3/4	17/8	3/16"	3/32	1 3/8"	3/4-1	1/3-1	1/8-1/2	-

### 1952-53 Rerate -- Designs A, B and C -- Open Type -- Squirrel Cage -- Integral hp Motors

182	9	6 1/2	4 1/2	3 3/4	2 1/4	13/32	2 3/4	2 1/4	7/8	3 1/6	3/32	1 3/8	1 1/2	1	3/4	1/2
184	9	7 1/2	4 1/2	3 3/4	2 3/4	13/32	2 3/4	2 1/4	7/8	3 1/6	3/32	1 3/8	3.2	2, 1 1/2	1 1/2, 1	3/4
213	10 1/2	7 1/2	5 1/4	4 1/4	2 3/4	13/32	3 1/2	3	1 1/8	1/4	1/8	2	5	3	2	1 1/2, 1
215	10 1/2	9	5 1/4	4 1/4	3 1/2	13/32	3 1/2	3	1 1/8	1/4	1/8	2	7 1/2	5	3	2
254U	12 1/2	10 3/4	6 1/4	5	4 1/8	17/32	4 1/4	3 3/4	1 3/8	5/16	5/32	2 3/4	10	7 1/2	5	3
256U	12 1/2	12 1/2	6 1/4	5	5	17/32	4 1/4	3 3/4	1 3/8	5/16	5/32	2 3/4	15	10	7 1/2	5
284U	14	12 1/2	7	5 1/2	4 3/4	17/32	4 3/4	4 7/8	1 5/8	3/8	3/16	3 3/4	20	15	10	7 1/2
286U	14	14	7	5 1/2	5 1/2	17/32	4 3/4	4 7/8	1 5/8	3/8	3/16	3 3/4	25	20	-	10
324U	16	14	8	6 1/4	5 1/4	21/32	5 1/4	5 5/8	1 7/8	1/2	1/4	4 1/4	-	25	15	-
324S*	16	14	8	6 1/4	5 1/4	21/32	5 1/4	3 1/4	1 5/8	3/8	3/16	1 7/8	30	-	-	-
326U	16	15 1/2	8	6 1/4	6	21/32	5 1/4	5 5/8	1 7/8	1/2	1/4	4 1/4	-	30	20	15
326S*	16	15 1/2	8	6 1/4	6	21/32	5 1/4	3 1/4	1 5/8	3/8	3/16	1 7/8	40	-	-	-
364U	18	15 1/4	9	7	5 5/8	21/32	5 7/8	6 3/8	2 1/8	1/2	1/4	5	-	40	25	20
364US*	18	15 1/4	9	7	5 5/8	21/32	5 7/8	3 3/4	1 7/8	1/2	1/4	2	50	-	-	-
365U	18	16 1/4	9	7	6 1/8	21/32	5 7/8	6 3/8	2 1/8	1/2	1/4	5	-	-	30	25
365US*	18	16 1/4	9	7	6 1/8	21/32	5 7/8	3 3/4	1 7/8	1/2	1/4	2	60	50	-	-
404U	20	16 1/4	10	8	6 1/8	13/16	6 5/8	7 1/8	2 3/8	5/8	5/16	5 1/2	-	-	40	30
404US*	20	16 1/4	10	8	6 1/8	13/16	6 5/8	4 1/4	2 1/8	1/2	1/4	2 3/4	75	60	-	-
405U	20	17 3/4	10	8	6 7/8	13/16	6 5/8	7 1/8	2 3/8	5/8	5/16	5 1/2	-	-	50	40
405US*	20	17 3/4	10	8	6 7/8	13/16	6 5/8	4 1/4	2 1/8	1/2	1/4	2 3/4	100	75	-	-
444U	22	1	11	9	7 1/4	13/16	7 1/2	8 5/8	2 3/8	3/4	3/8	7	-	-	60	50
444US*	22	18 1/2	11	9	7 1/4	13/16	7 1/2	4 1/4	2 1/8	1/2	1/4	2 3/4	125	100	-	-
445U	22	20 1/2	11	9	8 1/4	13/16	7 1/2	8 5/8	2 3/8	3/4	3/8	7	-	-	75	60
445US*	22	20 1/2	11	9	8 1/4	13/16	7 1/2	4 1/4	2 1/8	1/2	1/4	2 3/4	150	125	-	-

### 1964 Rerate -- Designs A, B and C -- Open Type -- Squirrel Cage -- Integral hp Motors

H143T	7	6	3 1/2	2 3/4	2	11/32	2 1/4	2 1/4	7/8	3/16	3/32	1 3/8	1 1/2	1	3/4	1/2
H145T	7	6	3 1/2	2 3/4	2 1/4	11/32	2 1/4	2 1/4	7/8	3/16	3/32	1 3/8	-	1 1/2	1	3/4
K145T	7	6	3 1/2	2 3/4	2 1/2	11/32	2 1/4	2 1/4	7/8	3/16	3/32	1 3/8	3.2	2	-	-
182T	9	6 1/2	4 1/2	3 3/4	2 1/4	13/32	2 3/4	2 3/4	1 1/8	1/4	1/8	1 3/4	5	3	1 1/2	1
184T	9	7 1/2	4 1/2	3 3/4	2 3/4	13/32	2 3/4	2 3/4	1 1/8	1/4	1/8	1 3/4	7 1/2	5	2	1 1/2
213T	10 1/2	7 1/2	5 1/4	4 1/4	2 3/4	13/32	3 1/2	3 3/8	1 3/8	5/16	5/32	2 3/8	10	7 1/2	3	2
215T	10 1/2	9	5 1/4	4 1/4	3 1/2	13/32	3 1/2	3 3/8	1 3/8	5/16	5/32	2 3/8	15	10	5	3
254T	12 1/2	10 3/4	6 1/4	5	4 1/8	17/32	4 1/4	4	1 5/8	3/8	3/16	2 7/8	20	15	7 1/2	5
256T	12 1/2	12 1/2	6 1/4	5	5	17/32	4 1/4	4	1 5/8	3/8	3/16	2 7/8	25	20	10	7 1/2
284T	14	12 1/2	7	5 1/2	4 3/4	17/32	4 3/4	4 5/8	1 7/8	1/2	1/4	3 1/4	-	25	15	10
284TS*	14	12 1/2	7	5 1/2	4 3/4	17/32	4 3/4	3 1/4	1 5/8	3/8	3/16	1 7/8	30	-	-	-
286T	14	14	7	5 1/2	5 1/2	17/32	4 3/4	4 5/8	1 7/8	1/2	1/4	3 1/4	-	30	20	15
286TS*	14	14	7	5 1/2	5 1/2	17/32	4 3/4	3 1/4	1 5/8	3/8	3/16	1 7/8	40	-	-	-
324T	16	14	8	6 1/4	5 1/4	21/32	5 1/4	5 1/4	2 1/8	1/2	1/4	3 7/8	-	40	25	20
324TS*	16	14	8	6 1/4	5 1/4	21/32	5 1/4	3 3/4	1 7/8	1/2	1/4	2	50	-	-	-
326T	16	15 1/2	8	6 1/4	6	21/32	5 1/4	5 1/4	2 1/8	1/2	1/4	3 7/8	-	50	30	25
326TS*	16	15 1/2	8	6 1/4	6	21/32	5 1/4	3 3/4	1 7/8	1/2	1/4	2	60	-	-	-
364T	18	15 1/4	9	7	5 5/8	21/32	5 7/8	5 7/8	2 3/8	5/8	5/16	4 1/4	-	60	40	30
364TS*	18	15 1/4	9	7	5 5/8	21/32	5 7/8	3 3/4	1 7/8	1/2	1/4	2	75	-	-	-
365T	18	16 1/4	9	7	6 1/8	21/32	5 7/8	5 7/8	2 3/8	5/8	5/16	4 1/4	-	75	50	40
365TS*	18	16 1/4	9	7	6 1/8	21/32	5 7/8	3 3/4	1 7/8	1/2	1/4	2	100	-	-	-
404T	20	16 1/4	10	8	6 1/8	13/16	6 5/8	7 1/4	2 7/8	3/4	3/8	5 5/8	-	100	60	50
404TS*	20	16 1/4	10	8	6 1/8	13/16	6 5/8	4 1/4	2 1/8	1/2	1/4	2 3/4	125	-	-	-
405T	20	17 3/4	10	8	6 7/8	13/16	6 5/8	7 1/4	2 7/8	3/4	3/8	5 5/8	-	125	75	60
405TS*	20	17 3/4	10	8	6 7/8	13/16	6 5/8	4 1/4	2 1/8	1/2	1/4	2 3/4	150	-	-	-
444T	22	18 1/2	11	9	7 1/4	13/16	7 1/2	8 1/2	3 3/8	7/8	7/16	6 7/8	-	-	100	75
444TS*	22	18 1/2	11	9	7 1/4	13/16	7 1/2	4 3/4	2 3/8	5/8	5/16	3	200	150	-	-
445T	22	20 1/2	11	9	8 1/4	13/16	7 1/2	8 1/2	3 3/8	7/8	7/16	6 7/8	-	-	125	100
445TS*	22	20 1/2	11	9	8 1/4	13/16	7 1/2	4 3/4	2 3/8	5/8	5/16	3	250	200	-	-

\* These motors are for direct coupled service only. ▲ Slots.

\* NEMA is believed to be a trademark and/or trade name of National Electrical Manufacturers Association, and is not owned or controlled by Regal Rexnord Corporation or its affiliates.

# GENERAL INFORMATION

## DECIMAL-MILLIMETER EQUIVALENTS

Fractional	Decimal	M.M.	Fractional	Decimal	M.M.	
	1/64	.015625	0.397	33/64	.515625	13.097
1/32	.03125	.794	17/32	.53125	13.494	
	3/64	.046875	1.191	35/64	.546875	13.891
1/16	.0625	1.588	9/16	.5625	14.288	
	5/64	.078125	1.984	37/64	.578125	14.684
	3/32	.09375	2.381	19/32	.59375	15.081
	7/64	.109375	2.778	39/64	.609375	15.478
1/8	.125	3.175	5/8	.625	15.875	
	9/64	.140625	3.572	41/64	.640625	16.272
	5/32	.15625	3.969	21/32	.65625	16.669
	11/64	.171875	4.366	43/64	.671875	17.066
3/16	.1875	4.763	11/16	.6875	17.463	
	13/64	.203125	5.159	45/64	.703125	17.859
	7/32	.21875	5.556	23/32	.71875	18.256
	15/64	.234375	5.953	47/64	.734375	18.653
1/4	.250	6.350	3/4	.750	19.050	
	17/64	.265625	6.747	49/64	.765625	19.447
	9/32	.28125	7.144	25/32	.78125	19.844
	19/64	.296875	7.541	51/64	.796875	20.241
5/16	.3125	7.938	13/16	.8125	20.638	
	21/64	.328125	8.334	53/64	.828125	21.034
	11/32	.34375	8.731	27/32	.84375	21.431
	23/64	.359375	9.128	55/64	.859375	21.828
3/8	.375	9.525	7/8	.875	22.225	
	25/64	.390625	9.922	57/64	.890625	22.622
	13/32	.40625	10.319	29/32	.90625	23.019
	27/64	.421875	10.716	59/64	.921875	23.416
7/16	.4375	11.113	15/16	.9375	23.813	
	29/64	.453125	11.509	61/64	.953125	24.209
	15/32	.46875	11.906	31/32	.96875	24.606
	31/64	.484375	12.303	63/64	.984375	25.003
1/2	.500	12.700	1	1.000	25.400	

## Horsepower and Torque

Horsepower is the common unit of mechanical power.

$$hp = \frac{\text{Force (Lbs.)} \times \text{Feet per Minute}}{33000}$$

$$hp = \frac{\text{Torque in In.-Lbs.} \times \text{rpm}}{63025}$$

One hp = .746 Kilowatt

One Kilowatt = 1.34 H.P.

Torque is a twisting moment or turning effort.

Torque in inch-pounds = Force (Lbs.) x Lever Arm (Inches)

$$\text{Torque in inch-pounds} = \frac{63025 \times hp}{\text{rpm}}$$

The following table gives the torque in inch-pounds for one hp at various speeds.

## Torque at One Horsepower

R.P.M.	In-Lbs.	R.P.M.	In-Lbs.	R.P.M.	In-Lbs.	R.P.M.	In-Lbs.
3500	18	580	109	90	700	14	4502
3000	21	500	126	80	788	12	5252
2400	26	400	158	70	900	10	6300
2000	32	300	310	60	1050	8	7878
1750	36	200	315	50	1260	6	10504
1600	39	180	350	40	1576	5	12605
1200	53	160	394	30	2101	4	15756
1160	54	140	450	20	3151	3	21008
1000	63	120	525	18	3501	2	31513
870	72	100	630	16	3939	1	63025

To find torque at any horsepower multiply values in table above by the horsepower required.

For intermediate speeds interpolate values in table above or solve the torque formula above.

## Minimum Sheave Sizes NEMA® Standards

The National Electrical Manufacturers Association recommends certain limitations on sheave diameter and width for satisfactory motor operation. The selected sheave diameter should not be smaller nor the width greater than the dimensions below. These dimensions are from NEMA Standard MG1-14.42.

Frame	Horsepower at				V-Belt Sheave (in.)			
	Sync. Speed, rpm				Conventional		358	
					A, B, C, D, and E Sections		3V, 5V, and 8V Sections	
	3600	1800	1200	900	Min. Pitch Dia.	Max Width	Min. Outside Dia	Max. Width
143T	1 1/2	-	3/4	1/2	2.2	4 1/4	2.2	2 1/4
143T	2-3	-	1	3/4	2.4	4 1/4	2.4	2 1/4
182T	3	3	1 1/2	1	2.4	5 1/4	2.4	2 3/4
182T	5	-	-	-	-	5 1/4	2.4	2 3/4
184T	-	-	2	1 1/2	2.4	5 1/4	2.4	2 3/4
184T	5	-	-	-	2.6	5 1/4	2.4	2 3/4
184T	7 1/2	-	-	-	3.0	5 1/4	3.0	2 3/4
213T	7 1/2-10	7 1/2	3	2	3.0	6 1/2	3.0	3 3/8
215T	10	-	5	3	3.0	6 1/2	3.0	3 3/8
215T	15	10	-	-	3.8	6 1/2	3.8	3 3/8
254T	15	-	7 1/2	5	3.8	6 1/2	3.8	4
254T	20	15	-	-	4.4	6 1/2	4.4	4
256T	20-25	-	10	7 1/2	4.4	6 1/2	4.4	4
256T	-	20	-	-	4.6	6 1/2	4.4	4
284T	-	-	15	10	4.6	9	4.4	4 5/8
284T	-	25	-	-	5.0	9	4.4	4 5/8
286T	-	30	20	15	5.4	9	5.2	4 5/8
324T	-	40	25	20	6.0	10 1/4	6.0	5 1/4
326T	-	50	30	25	6.8	10 1/4	6.8	5 1/4
364T	-	-	40	30	6.8	11 1/2	6.8	5 7/8
364T	-	60	-	-	7.4	11 1/2	7.4	5 7/8
365T	-	-	50	40	8.2	11 1/2	8.2	5 7/8
365T	-	75	-	-	9.0	11 1/2	8.6	5 7/8
404T	-	-	60	-	9.0	14 1/4	8.0	7 1/4
404T	-	-	-	50	9.0	14 1/4	8.4	7 1/4
404T	-	100	-	-	10.0	14 1/4	8.6	7 1/4
405T	-	-	75	60	10.0	14 1/4	10.0	7 1/4
405T	-	100	-	-	10.0	14 1/4	8.6	7 1/4
405T	-	125	-	-	11.5	14 1/4	10.5	7 1/4
444T	-	-	100	-	11.0	16 3/4	10.0	8 1/2
444T	-	-	-	75	10.5	16 3/4	9.5	8 1/2
444T	-	125	-	-	11.0	16 3/4	9.5	8 1/2
444T	-	150	-	-	-	-	10.5	8 1/2
445T	-	-	125	-	12.5	16 3/4	12.0	8 1/2
445T	-	-	-	100	10.5	16 3/4	12.0	8 1/2
445T	-	150	-	-	-	-	10.5	8 1/2
445T	-	200	-	-	-	-	13.2	8 1/2

To obtain the minimum pitch diameters for flat belt, Gearbelt® belt, chain or gear drives, multiply the 358 sheave pitch diameters in the table above by the following factors:

Product	Factors
Chain	0.70
Flat Belt (Single Ply)	1.33
Gearbelt	0.90
Helical Gear	0.85
Poly-V	1.00
Spur Gear	0.75

\* NEMA is believed to be the trademark or trade name of National Electrical Manufacturers Association and is not owned or controlled by Regal Rexnord Corporation or its affiliates.

## A

A Griproll.....	Discontinued
A Griptwist® belt .....	18
AA51 - AA128 .....	14
AK30H - AK184H .....	36
AK104x5/8 - AK124x 1 7/16 .....	35
AL54 - AL124 .....	Discontinued
AM144 .....	Discontinued
AS15 - AS34 .....	Discontinued
ATH, ATP, ATQ, ATQ-1, ATN1 .....	157
AX20 - AX180 .....	12
AZ15 - AZ140 .....	Discontinued
A20 - A180 .....	11

## B

B x 1/2 - 2 7/16.....	127 - 128
B Griproll.....	Discontinued
B Griptwist .....	18
BB45 - BB300 .....	14
Belt Rack.....	164
Belt Rule .....	164
Belt Tension Checker.....	164
BK24 - BK190.....	39
BK30H - BK190H .....	40
BS24 - BS32 .....	34
BX27 - BX300 .....	12
B25 - B360.....	11
B437 Fastener .....	Discontinued
B43740 - B43750 .....	Discontinued

## C

C Griproll.....	Discontinued
C Griptwist .....	Discontinued
CC75-CC360 .....	14
CC360DC - CC720DC .....	14
CX51 - CX360 .....	12
C51 - C420 .....	11
C531 Fastener .....	Discontinued
C53155 .....	Discontinued
C62540, C62560.....	Discontinued

## D

DATN1, DATQ1, DATSH, DATSP, DATSQ .....	155
D Griproll.....	Discontinued
D120 - D660.....	11
DX120-DX360 .....	12

## E - F

E 7/8 - E 3 1/2 .....	129 - 130
E 35 MM - E 75 MM.....	130
F 1 - F 4.....	129 - 130
F 45 MM - F 90 MM.....	130
FATH, FATN1, FATP, FATQ, FATQ-1.....	156
FHP 1K - 23K .....	Discontinued
FHP 1 - 23.....	Discontinued

## G - H

G 3/8 - G 1 .....	127 - 128
G 10 MM - G 25 MM .....	128
General Information.....	170
Groove Gauge.....	161
H x 3/8 - 1 1/2 .....	127 - 128
H 1 3/8 21 SPL B .....	128
H 1 3/8 6 SPL B .....	128
H 10 MM - H 38 MM .....	128
HB40 HUB - HB100 HUB.....	131
HCH1 HUB, HCP1 HUB, HCQL HUB .....	131
HG1 HUB, HH1 HUB .....	131
HP1 HUB, HP2 HUB.....	131
HQ1 HUB, HQ2 HUB.....	131
HR1 HUB, HR2 HUB .....	131
HS1 HUB, HS2 HUB .....	131
HU0 HUB, HU1 HUB, HU2 HUB .....	131
HW1 HUB.....	131

## I - J - K

IDH1 1/2 - IDR1 1 1/2 .....	159
J 1 1/2 - J 4 1/2.....	129 - 130
J 50 MM - J 100 MM.....	130
JA 1/2 - JA 1 1/4 .....	129 - 130
JP1 - JS9R .....	Discontinued
JS4N Insert - JS9N Insert.....	Discontinued
JZ1N Insert - JZ3N Insert .....	Discontinued
K 1 KEY - K 410 KEY .....	160

## L - M

L035 - L225.....	Discontinued
M 2 - M 5 1/2.....	129 - 130
MB145TX BASE - MB365TX BASE.....	162

## N

N 2 7/16 - N 5 7/8.....	129 - 130
NAK25 IDLER, NAK30 IDLER, NAK41 IDLER .....	159
NBK40 IDLER, NBK52 IDLER.....	159
NOK17 IDLER.....	159
N1 - N6 TIGHTENER SHAFT .....	159
N1D05F IDLER .....	159
N4D1F IDLER - N4D6F IDLER.....	159

## O - P

O 1 KEYSTOCK - O 410 KEYSTOCK.....	160
OK12X3/8 - OK100X3/4.....	Discontinued
OL50X5/8 - OL70X5/8.....	Discontinued
P1 1/2 - P1 1 3/4 .....	127-128
P1 1 1/4 - 1 3/8 10 SPL B.....	128
P1 1 1/8 - 1 3/8 6 SPL B.....	128
P1 1 3/8 21 SPL B.....	128
P1 14 MM - P1 42 MM.....	128
P1 978 10 SPL B .....	128
P2 3/4 - P2 1 3/4 .....	127-128
P3 1 1/8 - P3 1 5/8 .....	127-128

# ALPHA-NUMERICAL PART NUMBER INDEX

## Q - R

Q1 3/4 - Q3 2 1/2	127-128
Q1 1 1/8 - Q2 1 3/8 6 SPL B	128
Q1 1 3/8 10 SPL B - Q1 1 3/8 21 SPL B	128
Q1 18 MM - Q1 65 MM	128
RUBRB-112 - RUBRB-116	142
RUBRS-108 - RUBRS-116	142
R1 1 1/8 - R2 3 5/8	127-128
R1 28 MM - R2 90 MM	128

## S

SATH, SATN1, SATP, SATQ, SATQ-1	156
SD 1/2 - SD 2	129-130
SD 24 MM - SD 42 MM	130
SDS 1/2 - SDS 2	129-130
SDS 24 MM - SDS 48 MM	130
SF 1/2 - SF 2 15/16	129-130
SF 28 MM - SF 60 MM	130
SH 1/2 - SH 1 5/8	129-130
SH 24 MM - SH 35 MM	130
SIB40 - SIB70	Discontinued
SK 1/2 - SK 2 5/8	129-130
SK 24 MM - SK 55 MM	130
SPB1000	Discontinued
SPB1100	Discontinued
SSF2S-108 - SSF2S-120S	145
SSF4S-124 - SSF4S-131	146
SSPS-114 - SSPS120S	146
SSRPS-112 - SSRPS-116	146
S1 1 11/16 - S2 4 1/4	127-128

## T - U - V

U0 2 3/8 - U2 5	127-128
VF2S-212AH - VF2S-235AH	137
VF2S-316AH - VF2S-328AH	140
VF4S-208AH - VF4S-247AH	138
VF4S-319AH - VF4S-340AH	141
VPB-212AH - VPB-239AH	149
VPB-316AH - VPB-335AH	150
VPLS-212AH - VPLS-247AH	136
VPS-208AH - VPS-239AH	135
VPS-316AH - VPS-355AH	139

## W

Warranty - See Standard Terms and Conditions	178
W1 3 3/8 - W2 7 7/16	127-128

## 1

1B110SDS - 1B136SDS	72
1B136SDS - 1B200SKS	72
1B34SH - 1B44SH	72
1B46SDS - 1B94SDS	72
1B5V42 - 1B5V278	45
1C56P, 1C60Q	59
1C70SF - 1C240SF	76
1F3V26X5/8 - 1F3V33X7/8	63
1G3V26 - 1G3V30	64
1H3V31 - 1H3V60	64
1P3V36 - 1P3V106	64

1Q3V140 - 1Q3V250	64
1TA30 - 1TA245	Discontinued
1TB34 - 1TB380	48
1TC70 - 1TC240	55
1VL25X1/2 - 1VL44X7/8	112
1VM50X1/2 - 1VM50X7/8	112
1VP25X1/2 - 1VP75X 1 5/8	110
13V800SDS - 13V1060SDS	79
13V1400SK, 13VI 900SK	79
13V220JA - 13V335JA	79
13V365SH - 13V690SH	79

## 2

2AK20X1/2 - 2AK184X 1 7/16	36
2AK30H - 2AK184H	37
2BK25X1/2 - 2BK190X 1 7/16	40
2BK32H - 2BK190H	41
2B70SK - 2B74SK	72
2B54Q - 2B380R	52
2B200SF - 2B380SF	73
2B34SH - 2B44SH	72
2B46SDS - 2B68SDS	72
2B5V42 - 2B5V66	45
2B5V68 - 2B5V278	46
2B80SK - 2B184SK	73
2C70SF - 2C240SF	76
2C56P - 2C440R	59
2C300F	76
2F3V26X3/4 - 2F3V33X 1 1/8	63
2GBBX55 - 2GBB240	13
2GBCX75 - 2GBC300	13
2GB3VX450 - 2GB3V1400	19
2GB5VX670 - 2GB5V3000	19
2G3V26-2G3V30	65
2H3V31-2H3V60	65
2L120 - 2L345	15
2MVP60B74P - 2MVP70B84P	115
2MVP75C97Q - 2MVP115C137Q	118
2MVP35B49X7/8 - 2MVP55B69X 1 5/8	114
2P3V36 - 2P3V60	65
2P5V44	67
2Q3V65 - 2Q3V250	65
2Q5V46 - 2R5V280	67
2TA30 - 2TA245	Discontinued
2TB34 - 2TB380	48
2TC70 - 2TC240	56
2VP36X1/2 - 2VP75X1 3/8	111
2VP60x1 5/8 - 2VP75x1 5/8	111
23V220JA - 23V315JA	79
23V335SH - 23V600SH	79
23V650SDS - 23V800SDS	79
23V1060SK - 23V1900SK	79
23V2500SF	79
25V440SH	82
25V465SDS - 25V590SDS	82
25V630SK - 25V1180SK	82
25V1250SF - 25V2120SF	82
25V2360E - 25V2800E	82



# ALPHA-NUMERICAL PART NUMBER INDEX

## 3

3BK45H - 3BK190H	Discontinued
3BK25X5/8 - 3BK40X 1 1/8	Discontinued
3B110SK - 3B184SK	73
3B154R - 3B380R	52
3B200SF - 3B300SF	73
3B34SH - 3B44SH	73
3B380E	73
3B46SD - 3B68SD	73
3B5V42 - 3B5V278	46
3B54Q - 3B68Q	52
3B70SK - 3B184SK	73
3C80E - 3C240E	77
3C90R - 3C500R	59
3C50Q - 3C60Q	59
3C50SD - 3C55SD	77
3C500S	59
3C56P	59
3C60SF - 3C75SF	77
3F3V26X7/8 - 3F3V33X 1 1/8	63
3GBBX51 - 3GBB240	13
3GBCX75 - 3GBCX112	13
3GBC120 - 3GBC300	13
3GB3VX450 - 3GB3V1400	19
3GB5VX670 - 3GB5V3000	19
3G3V26 - 3G3V30	65
3H3V31, 3H3V33	65
3L120 - 3L630	15
3MVB50P - 3MVB380R	116
3MVC80Q - 3MVC500U	120
3MVP35B49X 1 1/8 - 3MVP70B84X 1 7/8	114
3MVP60B74P - 3MVP80B94Q	115
3MVP75C97Q - 3MVP115C137Q	118
3MVP815V95Q - 3MVP1115V125Q	122
3MV5V80R - 3MV5V200R	123
3MV5V212S - 3MV5V300S	123
3MV5V375U - 3MV5V500U	123
3P3V36 - 3P3V60	65
3P5V44	67
3Q3V65 - 3Q3V140	65
3Q5V46 - 3Q5V75	65
3R3V190 - 3R3V335	65
3R5V80 - 3S5V375	67
3TA30 - 3TA245	Discontinued
3TB34 - 3TB380	49
3TC70 - 3TC240	56
3U5V500	67
3VX250 - 3VX1400	18
33V800SK - 33V1400SK	80
33V1900SF, 33V3350SF	80
33V250JA	80
33V300SH - 33V412SH	80
33V450SDS - 33V690SDS	80
35V710SF - 35V1180SF	82
35V1250E - 35V1320E	82

35V1400E - 35V2800E	83
35V3150F, 35V5000F	83
35V440SDS - 35V590SDS	82
35V630SK - 35V670SK	82
3839 Belt Rule	161

## 4

4B110SK - 4B136SK	74
4B154R - 4B380R	53
4B154SF - 4B200SF	74
4B250E - 4B380E	74
4B34SD - 4B68SD	74
4B5V42 - 4B5V278	46
4B50SD - 4B68SD	74
4B54Q - 4B68Q	53
4B70SK - 4B136SK	74
4C80E - 4C200E	77
4C90R - 4C500R	59
4C180S - 4C360S	59
4C240F - 4C360F	77
4C440J - 4C500J	77
4C440U - 4C500U	59
4C50Q - 4C60Q	59
4C50SD - 4C55SD	77
4C56P	59
4C60SF - 4C75SF	77
4F3V26X7/8 - 4F3V33X 1 3/8	63
4GBBX56 - 4GBB240	13
4GBCX75 - 4GBC300	13
4GB3VX450 - 4GB3V1400	19
4GB5VX670 - 4GB5V3000	19
4G3V26 - 4G3V30	65
4H3V31, 4H3V33	65
4L170 - 4L1000	15
4MVB50Q - 4MVB380R	116
4MVC80Q - 4MVC500U	120
4MVP35B49X 1 1/8 - 4MVP70B84X 2 1/8	114
4MVP75C97Q - 4MVP115C137Q	118
4MVP60B74P - 4MVP70B84P	115
4MVP80B94Q	115
4MVP815V95X 2 1/8 - 4MVP1115V125X 2 7/8	122
4MV5V80R - 4MV5V500U	123
4P3V36 - 4P3V56	65
4P5V44	68
4Q3V60 - 4Q3V140	65
4Q5V46 - 4Q5V75	68
4R3V190 - 4R3V335	65
4R5V80 - 4R5V212	68
4S5V280 - 4S5V375	68
4S8V125 - 4S8V212	70
4TA30 - 4TA245	Discontinued
4TB34 - 4TB380	50
4TC70 - 4TC240	57
4U5V500	68
4U8V224 - 4U8V640	70
43V1900SF, 43V2500SF	80
43V265JA, 43V280JA	80
43V300SH - 43V412SH	80
43V3350E	80

# ALPHA-NUMERICAL PART NUMBER INDEX

43V450SDS - 43V560SDS .....	80
43V600SK - 43V1400SK .....	80
45V800E - 45V2120E .....	83
45V2360F - 45V3750F .....	83
45V440SD - 45V5000J .....	83
45V630SK - 45V670SK .....	83
45V710SF - 45V750SF .....	83
48V1250F - 48V5300M .....	86

## 5

5B70R - 5B380R .....	53
5B70SF - 5B184SF .....	74
5B34SD - 5B52SD .....	74
5B54SK - 5B68SK .....	74
5B5V42 - 5B5V250 .....	47
5B200E - 5B380E .....	74
5C90R - 5C500R .....	59
5C80E - 5C180E .....	77
5C180S - 5C300S .....	60
5C200F - 5C300F .....	77
5C360J - 5C500J .....	77
5C60SF - 5C75SF .....	77
5GB3VX1060 .....	19
5GB5VX1060 .....	19
5GB5VX1600 - 5GB5V1700 .....	19
5GB5V1700 .....	19
5L230 - 5L1000 .....	15
5MVB50Q - 5MVB380R .....	117
5MVC80R - 5MVC160R .....	121
5MVC180S - 5MVC360S .....	121
5MVC440U - 5MVC500U .....	121
5MVP35B49X 1 3/8 - 5MVP70B84X 2 1/8 .....	114
5MVP60B74P - 5MVP80B94Q .....	115
5MVP75C97X 1 7/8 - 5MVP115C137X 2 3/8 .....	119
5MVP815V95X 2 3/8 - 5MVP115V125X 3 3/8 .....	122
5MV5V80R - 5MV5V500U .....	124
5P3V47 - 5Q3V140 .....	66
5Q5V46 - 5Q5V75 .....	68
5R3V190 - 5R3V335 .....	66
5R5V80 - 5R5V160 .....	68
5S5V212 - 5S5V280 .....	68
5S8V125 - 5S8V212 .....	70
5TB34 - 5TB380 .....	51
5TC70 - 5TC240 .....	58
5U5V375 - 5U5V500 .....	68
5U8V224 - 5U8V640 .....	70
5VX450 - 5V3550 .....	18
53V1400SF - 53V1900SF .....	81
53V475SDS - 53V3350E .....	81
53V530SK - 53V1060SK .....	81
55V800E - 55V1600E .....	84
55V1870F - 55V2800F .....	84
55V440SD - 55V5000J .....	84
55V590SK - 55V630SK .....	84
55V670SF - 55V750SF .....	84
58V1250F - 58V5300N .....	86

5U8V224 - 5U8V640 .....	70
5VX450 - 5V3550 .....	18
53V1400SF - 53V1900SF .....	81
53V475SDS - 53V3350E .....	81
53V530SK - 53V1060SK .....	81
55V800E - 55V1600E .....	84
55V1870F - 55V2800F .....	84
55V440SD - 55V5000J .....	84
55V590SK - 55V630SK .....	84
55V670SF - 55V750SF .....	84
58V1250F - 58V5300N .....	86

## 6

6B5V42 - 6B5V250 .....	47
6B70R - 6B380R .....	53
6B70SF - 6B184SF .....	75
6B200E - 6B380E .....	75
6B34SD - 6B52SD .....	75
6B54SK - 6B68SK .....	75
6C90F - 6C240F .....	78
6C90R - 6C500R .....	60
6C300U - 6C360U .....	60
6C500M .....	78
6C60SF - 6C75SF .....	78
6C80E - 6C85E .....	78
6Q3V47-6Q3V80 .....	66
6Q5V71 - 6Q5V75 .....	69
6R3V106 - 6R3V335 .....	66
6R5V80 - 6R5V118 .....	69
6S5V125 - 6S5V280 .....	69
6S8V125 - 6S8V212 .....	71
6TB34 - 6TB380 .....	51
6TC70 - 6TC240 .....	58
6U5V375, 6U5V500 .....	69
6U8V224 - 6U8V640 .....	71
63V1060SF, 63V1400SF .....	81
63V475SK - 63V3350E .....	81
65V800E - 65V1180E .....	84
65V1250F - 65V2120F .....	84
65V2360J - 65V3750J .....	84
65V440SD - 65V5000M .....	84
65V590SK - 65V630SK .....	84
65V670SF - 65V750SF .....	84
68V1250F - 68V5300N .....	86

## 7

7C70Q - 7C500S .....	60
7C180U - 7C300U .....	60

## 8

8B86E - 8B154E.....	75
8B70R - 8B380R.....	54
8B184F - 8B380F.....	75
8B300S - 8B380S.....	54
8B54Q - 8B68Q.....	54
8B54SK - 8B56SK.....	78
8B60SF - 8B74SF.....	78
8C90F - 8C180F.....	78
8C80R - 8C160R.....	61
8C180S - 8C500S.....	61
8C180U - 8C440U.....	61
8C200J - 8C300J.....	78
8C360M - 8C500M.....	78
8C70Q.....	61
8C80E, 8C85E.....	78
8Q3V47 - 8Q3V69.....	66
8Q5V71 - 8Q5V75.....	69
8R3V80 - 8R3V250.....	66
8R5V80 - 8R5V90.....	69
8S3V335.....	66
8S5V92 - 8S5V160.....	69
8S8V125 - 8S8V160.....	71
8U5V212 - 8U5V500.....	69
8U8V170 - 8U8V300.....	71
8V1000 - 8V4500.....	18
8W8V400 - 8W8V640.....	71
83V800SF - 83V1060SF.....	81
83V1400E - 83V2500E.....	81
83V3350F.....	81
83V475SK - 83V690SK.....	81
85V710SF - 85V5000M.....	85
88V1250J - 88V6300P.....	87

# Edge™ (Engineered Design, Guaranteed Economy) V-Belt drive optimization software that selects the lowest cost, most torque dense drives.

This Solution is based on the use of COMPONENTS. Substitution of competitive product may result in reduced drive life and/or unsatisfactory performance.

No.	Driver Sheave	Driver Bushing	Driven Sheave	Driven Bushing	Belt	Qty	Actual C.D.	Actual S.F.	Driven Speed	Cost
<u>1.</u>	1VP75		1B5V110	B	5VX710	1	20.90	1.37	1167/977	1.000
If Driver is 0 turns open Driven RPM=1167 and CD=20.9 in. If Driver is 4 turns open Driven RPM=1041 and CD=21.49 in. Correct tension for this drive (8.74 Lb. should deflect belt 0.33 In.) will have 278 Lb. 'running' Hub Load										
<u>2.</u>	2VP60		2B5V86	B	BX61	2	20.20	1.26	1160/924	1.070
If Driver is 0 turns open Driven RPM=1160 and CD=20.2 in. If Driver is 3 turns open Driven RPM=1042 and CD=20.65 in. Correct tension for this drive (5.96 Lb. should deflect belt 0.32 In.) will have 344 Lb. 'running' Hub Load										
<u>3.</u>	2VP65		2B5V86	B	BX61	2	19.82	1.26	1258/1022	1.106
If Driver is 2.5 turns open Driven RPM=1160 and CD=20.2 in. If Driver is 5.5 turns open Driven RPM=1042 and CD=20.65 in. Correct tension for this drive (5.65 Lb. should deflect belt 0.31 In.) will have 342 Lb. 'running' Hub Load										
<u>4.</u>	2VP65		2B5V90	B	5VX650	2	20.29	2.05	1231/1000	1.265
If Driver is 1.5 turns open Driven RPM=1173 and CD=20.51 in. If Driver is 5 turns open Driven RPM=1038 and CD=21.04 in. Correct tension for this drive (5.5 Lb. should deflect belt 0.32 In.) will have 335 Lb. 'running' Hub Load										
<u>5.</u>	2VP65		2Q5V90	Q1	5VX650	2	20.45	1.95	1258/1022	1.507
If Driver is 2.5 turns open Driven RPM=1160 and CD=20.83 in. If Driver is 5.5 turns open Driven RPM=1042 and CD=21.28 in. Correct tension for this drive (5.48 Lb. should deflect belt 0.32 In.) will have 342 Lb. 'running' Hub Load										
<u>6.</u>	2VP65		2Q5V92	Q1	5VX650	2	20.21	2.05	1217/989	1.537
If Driver is 1.5 turns open Driven RPM=1160 and CD=20.43 in. If Driver is 5 turns open Driven RPM=1027 and CD=20.95 in. Correct tension for this drive (5.5 Lb. should deflect belt 0.32 In.) will have 332 Lb. 'running' Hub Load										
<u>7.</u>	2VP75		2B5V110	B	5VX710	2	20.90	2.75	1167/977	1.653
If Driver is 0 turns open Driven RPM=1167 and CD=20.9 in. If Driver is 4 turns open Driven RPM=1041 and CD=21.49 in. Correct tension for this drive (5.17 Lb. should deflect belt 0.33 In.) will have 278 Lb. 'running' Hub Load										
<u>8.</u>	2VP75		2Q5V109	Q1	5VX690	2	20.14	2.63	1199/1005	1.904
If Driver is 1 turns open Driven RPM=1167 and CD=20.29 in. If Driver is 5 turns open Driven RPM=1037 and CD=20.88 in. Correct tension for this drive (5.17 Lb. should deflect belt 0.31 In.) will have 285 Lb. 'running' Hub Load										
<u>9.</u>	2VP75		25V1130SK	SK	5VX710	2	20.81	2.74	1156/969	1.960
If Driver is 0 turns open Driven RPM=1156 and CD=20.81 in. If Driver is 4 turns open Driven RPM=1031 and CD=21.4 in. Correct tension for this drive (5.18 Lb. should deflect belt 0.33 In.) will have 276 Lb. 'running' Hub Load										
<u>10.</u>	2MVP45B59		2B5V90	B	BX62	2	20.14	1.38	1167/903	2.185
If Driver is 0.25 turns open Driven RPM=1167 and CD=20.14 in. If Driver is 3 turns open Driven RPM=1035 and CD=20.67 in. Correct tension for this drive (5.79 Lb. should deflect belt 0.31 In.) will have 330 Lb. 'running' Hub Load										
<b>Drives above meet your criteria - Selection below is best disregarding options</b>										
	1VP75		1B5V110	B	5VX710	1	20.90	1.37	1167/977	1.000
If Driver is 0 turns open Driven RPM=1167 and CD=20.9 in. If Driver is 4 turns open Driven RPM=1041 and CD=21.49 in. Correct tension for this drive (8.74 Lb. should deflect belt 0.33 In.) will have 278 Lb. 'running' Hub Load										

Input hp 15.0  
Service Factor 1.25  
Driver rpm 1750  
Driver shaft 1.625"  
Driven rpm 1100  
Driven shaft 2.0"  
Min. center distance 20"  
Variable speed

## EDGE OPTIONAL DRIVE SELECTION FROM THE WORLD'S LARGEST SELECTION OF V-BELT DRIVES

- Today's most trusted OEM design tool.

**STANDARD TERMS AND CONDITIONS OF SALE (February 2015)**

\*These Terms and Conditions, the attendant quotation or acknowledgment and all documents incorporated by specific reference therein, will be the complete and exclusive statement of the terms of the agreement governing the sale of goods ("Goods") by Regal Rexnord Corporation and its divisions and subsidiaries ("Seller") to Customer ("Buyer"). Buyer's acceptance of the Goods will manifest Buyer's assent to these Terms and Conditions. If these Terms and Conditions differ in any way from the terms and conditions of Buyer's order, or other documentation, this document will be construed as a counteroffer and will not be deemed an acceptance of Buyer's terms and conditions which conflict herewith.

\*These Terms and Conditions of Sale are subject to change without notice at Seller's discretion.

1. **PRICES:** Unless otherwise specified in writing by Seller, Seller's price for the goods shall remain in effect for thirty (30) days after the date of Seller's quotation or acknowledgment of Buyer's order for the Goods, whichever occurs first, provided an unconditional, complete authorization for the immediate shipment of the Goods is received and accepted by Seller within such time period. If such authorization is not received by Seller within such thirty (30) day period, Seller shall have the right to change the price for the Good to Seller's price for the Goods at the time of shipment.

2. **TAXES:** Any tax or governmental charge or increase in same hereafter becoming effective increasing the cost to Seller of producing, selling or delivering the Goods/provision of Services or of procuring material used therein, and any tax now in effect or increase in same payable by the Seller because of the manufacture, sale or delivery of the Goods/provision of Services, may at Seller's option, be added to the price.

3. **TERMS OF PAYMENT:** Subject to the approval of Seller's Credit Department, terms are net thirty (30) days from date of Seller's invoice in U.S. currency. If any payment owed to Seller is not paid when due, it shall bear interest, at a rate to be determined by Seller, which shall not exceed the maximum rate permitted by law, from the date on which it is due until it is paid. Seller shall have the right, among other remedies, either to terminate the Agreement or to suspend further performance under this and/or other agreements with Buyer in the event Buyer fails to make any payment when due. Buyer shall be liable for all expenses, including attorneys' fees, relating to the collection of past due amounts.

4. **SHIPMENT AND DELIVERY:** Shipments are made F.O.B. Seller's shipping point. Any claims for shortages or damages suffered in transit shall be submitted by the Buyer directly to the carrier. While Seller will use all reasonable commercial efforts to maintain the delivery date for the Goods or the date of provision of Services acknowledged or quoted by Seller, all such dates are approximate. Seller reserves the right to make partial shipments and to segregate "specials" and made-to-order Goods from normal stock Goods. Seller shall not be bound to tender delivery of any Goods for which Buyer has not provided shipping instructions.

5. **QUANTITY:** Buyer agrees to accept overruns of up to ten percent (10%) of the order on "made-to-order" Goods, including parts. Any such additional items shall be priced at the price per item charged for the specific quantity ordered.

6. **LIMITED WARRANTY:** Subject to the limitations of Section 7, Seller warrants that the Goods will be free from defects in material and workmanship under normal use, service and maintenance and Services will be performed by trained personnel using proper equipment and instrumentation for the particular Service provided. Any licensed firmware embodied in the Goods will execute the programming instructions provided by Seller. The foregoing warranties will apply until the expiration of the applicable warranty period. Except as specified below, Goods are warranted for twelve (12) months (unless otherwise specified by Seller in writing) from the date of shipment of the Goods by Seller. Consumables and Services (except as specified below) are warranted for a period of 90 days from the date of shipment or completion of the Services. Products purchased by Seller from a third party for resale to Buyer ("Resale Products") shall carry only the warranty extended by the original manufacturer. Buyer agrees that Seller has no liability for Resale Products beyond making a reasonable commercial effort to arrange for procurement and shipping of the Resale Products. **THIS IS THE SOLE AND EXCLUSIVE WARRANTY GIVEN BY SELLER WITH RESPECT TO THE GOODS/SERVICES AND IS IN LIEU OF AND EXCLUDES ALL OTHER WARRANTIES, EXPRESS OR IMPLIED, ARISING BY OPERATION OF LAW OR OTHERWISE, INCLUDING WITHOUT LIMITATION, MERCHANTABILITY OR FITNESS FOR A PARTICULAR PURPOSE WHETHER OR NOT THE PURPOSE OR USE HAS BEEN DISCLOSED TO SELLER IN SPECIFICATIONS, DRAWINGS OR OTHERWISE, AND WHETHER OR NOT SELLER'S PRODUCTS ARE SPECIFICALLY DESIGNED AND/OR MANUFACTURED BY SELLER FOR BUYER'S USE OR PURPOSE.**

This warranty does not extend to any losses or damages due to misuse, accident, abuse, neglect, normal wear and tear, unauthorized modification or alteration, use beyond rated capacity, or improper installation, maintenance or application. To the extent that Buyer or its agents has supplied specifications, information, representation of operating conditions or other data to Seller in the selection or design of the Goods or provision of Services and the preparation of Seller's quotation, and in the event that actual operating conditions or other conditions differ from those represented by Buyer, any warranties or other provisions contained herein which are affected by such conditions shall be null and void. If within thirty (30) days after Buyer's discovery of any warranty defects within the warranty period, Buyer notifies Seller thereof in writing, Seller shall, at its option, repair, correct, or replace F.O.B. point of manufacture, or refund the purchase price for, that portion of the goods found by Seller to be defective. Failure by Buyer to give such written notice within the applicable time period shall be deemed an absolute and unconditional waiver of Buyer's claim for such defects. Goods repaired or replaced during the warranty period shall be covered by the foregoing warranty for the remainder of the original warranty period or ninety (90) days, whichever is longer. Buyer assumes all other responsibility for any loss, damage, or injury to persons or property arising out of, connected with, or resulting from the use of Goods, either alone or in combination with other products/components.

**SECTIONS 6 AND 7 APPLY TO ANY ENTITY OR PERSON WHO MAY BUY, ACQUIRE OR USE SELLER'S GOODS, INCLUDING ANY ENTITY OR PERSON WHO BUYS THE GOODS FROM SELLER'S DISTRIBUTOR AND SUCH ENTITY OR PERSON SHALL BE BOUND BY THE LIMITATIONS THEREIN.**

7. **LIMITATION OF REMEDY AND LIABILITY; THE SOLE AND EXCLUSIVE REMEDY FOR BREACH OF ANY WARRANTY HEREUNDER (OTHER THAN THE WARRANTY PROVIDED UNDER SECTION 13) SHALL BE LIMITED TO REPAIR, CORRECTION, REPLACEMENT, OR REFUND OF THE PURCHASE PRICE UNDER SECTION 6. SELLER SHALL NOT BE LIABLE FOR DAMAGES CAUSED BY DELAY IN PERFORMANCE AND IN NO EVENT, REGARDLESS OF THE FORM OF THE CLAIM OR CAUSE OF ACTION (WHETHER BASED IN CONTRACT, INFRINGEMENT, NEGLIGENCE, STRICT LIABILITY, OTHER TORT OR OTHERWISE), SHALL SELLER'S LIABILITY TO BUYER AND/OR ITS CUSTOMERS EXCEED THE PRICE TO BUYER OF THE SPECIFIC GOODS OR SERVICES PROVIDED BY SELLER GIVING RISE TO THE CLAIM OR CAUSE OF ACTION. BUYER AGREES THAT IN NO EVENT SHALL SELLER'S LIABILITY TO BUYER AND/OR ITS CUSTOMERS EXTEND TO INCLUDE INCIDENTAL, CONSEQUENTIAL OR PUNITIVE DAMAGES. THE TERM "CONSEQUENTIAL DAMAGES" SHALL INCLUDE, BUT NOT BE LIMITED TO, LOSS OF ANTICIPATED PROFITS, LOSS OF USE, LOSS OF REVENUE, COST OF CAPITAL AND DAMAGE OR LOSS OF OTHER PROPERTY OR EQUIPMENT AND COSTS INCURRED INCLUDING WITHOUT LIMITATION FOR CAPITAL, FUEL AND POWER, AND CLAIMS OF BUYER'S CUSTOMERS. GOODS AND/OR SERVICES SOLD HEREUNDER ARE NOT FOR USE IN ANY NUCLEAR AND RELATED APPLICATIONS.**

Buyer accepts goods and/or services with the foregoing understanding, agrees to communicate the same in writing to any subsequent purchaser or users and to defend, indemnify and hold harmless Seller from any claims, losses, suits, judgments and damages, including incidental and consequential damages, arising from such use, whether the cause of action be based in tort, contract or otherwise, including allegations that the Seller's liability is based on negligence or strict liability.

8. **BUYER RESPONSIBILITIES:** Buyer shall provide Seller ready access to the site where services are to be performed and adequate workspace and facilities to perform same as provided in these terms and conditions. Buyer shall not require Seller or its employees, as a condition to site access or otherwise, to further agree or enter into any agreement, which waives, releases, indemnifies or otherwise limits or expands any rights or obligations whatsoever. Any such agreements shall be null and void. Buyer shall inform Seller, in writing, at the time of order placement, of any known hazardous substance or condition at the site, including, but not limited to, the presence of asbestos or asbestos containing materials, and shall provide Seller with any applicable Material Data Safety Sheets regarding same. Buyer shall appoint a representative familiar with the site and the nature of the services to be performed by Seller to be present at all times that Seller personnel are at the site. Seller shall not be liable for any expenses incurred by Buyer in removing, replacing or refurbishing any Buyer equipment or any part of Buyer's building structure that restricts Seller access. Buyer personnel shall cooperate with and provide all necessary assistance to Seller. Seller shall not be liable or responsible for any work performed by Buyer.

9. **BUYER SUPPLIED DATA:** To the extent that Seller has relied upon any data or information supplied by Buyer to Seller ("Data") in the selection or design of the Goods and/or provision of the Services and the preparation of Seller's quotation, and the Data is inadequate or inaccurate, any warranties or other provisions contained herein which are affected by such conditions shall be null and void.

10. **TECHNICAL ADVICE:** It is expressly understood that the Seller assumes no obligation or liability for any technical advice given without charge and furnished by the Seller with respect to the use of the Goods. All such technical advice, or results obtained, is given and accepted at Buyer's risk.

11. **EXCUSE OF PERFORMANCE:** Seller shall not be liable for delays in performance or for non-performance due to acts of God, acts of Buyer, war, riot, fire, flood, other severe weather, sabotage, or epidemics; strikes or labor disturbances; governmental requests, restrictions, laws, regulations, orders or actions; unavailability of or delays in transportation; default of suppliers; or unforeseen circumstances or any events or causes beyond Seller's reasonable control. Deliveries of Goods or provision of Services may be suspended for an appropriate period of time as a result of the foregoing. If Seller determines that its ability to supply the total demand for the Goods, or to obtain material used directly or indirectly in the manufacture of the Goods, is hindered, limited or made impracticable due to causes addressed in this Section 8, Seller may allocate its available supply of the Goods or such material (without obligation to acquire other supplies of any such Goods or material) among itself and its purchasers on such basis as Seller determines to be equitable without liability for any failure of performance which may result therefrom. Deliveries suspended or not made by reason of this section may be canceled by Seller upon notice to Buyer without liability, but the balance of the agreement shall otherwise remain unaffected.

12. **CANCELLATIONS AND DELAYS:** The Buyer may cancel orders only upon written notice and upon payment to Seller of cancellation charges which include, among other things, all costs and expenses incurred and commitments made by the Seller and a reasonable profit thereon. Any request by Buyer to extend the delivery schedule must be agreed to in writing by the Seller. If agreement cannot be reached, Seller may deliver product or provide services to the last known ship to address and invoice the Buyer upon completion of the product or services or prior delivery date, whichever is later.

13. **CHANGES:** Buyer may request changes or additions to the Goods/Services consistent with Seller's specifications and criteria. In the event such changes or additions are accepted by Seller, Seller may revise the price and delivery schedule. Seller reserves the right to change designs and specifications for the Goods or Services without prior notice to Buyer, except with respect to Goods being made-to-order for Buyer. Seller may cancel any order or terminate any agreement without liability to Buyer if Buyer fails to meet the conditions specified herein.

14. **TOOLING:** Tool, die, and pattern charges, if any, are in addition to the price of the Goods/Services and are due and payable upon completion of the tooling. All such tools, dies and patterns shall be and remain the property of Seller. Charges for tools, dies, and patterns do not convey to Buyer, title, ownership interests in, or rights to possession or removal, nor prevent their use by Seller for other purchasers, except as otherwise expressly provided by Seller and Buyer in writing with reference to this provision.

15. **SOFTWARE AND FIRMWARE:** Notwithstanding any other provision herein to the contrary, Seller or applicable third party owner shall retain all rights of ownership and title in its respective firmware and software, including all copyrights relating to such firmware and software and all copies of such firmware and software. Except as otherwise provided herein, Buyer is hereby granted a nonexclusive, royalty free license to use firmware and software, and copies of firmware and software, incorporated into the Goods only in conjunction with such Goods and only at the Buyer's plant site where the Goods are first used. Buyer's use of certain firmware (as specified by Seller) and all other software shall be governed exclusively by Seller's and/or third party owner's applicable license terms.

16. **ASSIGNMENT:** Buyer shall not assign its rights or delegate its duties hereunder or any interest therein or any rights hereunder without the prior written consent of the Seller, and any such assignment, without such consent, shall be void.

17. **PATENTS AND COPYRIGHTS:** Subject to Section 7, Seller warrants that the Goods and/or Services sold, except as are made specifically for Buyer according to Buyer's specifications, do not infringe any valid U.S. patent or copyright in existence as of the date of delivery. This warranty is given upon the condition that Buyer promptly notify Seller of any claim or suit involving Buyer in which such infringement is alleged, and, that Buyer cooperate fully with Seller and permit Seller to control completely the defense or compromise of any such allegation of infringement. Seller's warranty as to use only applies to infringements arising solely out of the inherent operation (i) of such Goods, or (ii) of any combination of Goods in a system designed by Seller. In the event such Goods and/or Services, singularly or in combination, are held to infringe a U.S. patent or copyright in such suit, and the use of such Goods and/or Services is enjoined, or in the case of a compromise by Seller, Seller shall have the right, at its option and expense, to procure for Buyer the right to continue using such Goods or providing such Services, or replace them with non-infringing Goods or Services; or modify same to become non-infringing; or grant Buyer a credit for the depreciated value of such Goods and accept return of them or grant Buyer a credit for such provided Services.

18. **EXPORT/IMPORT:** Buyer agrees that all applicable import and export control laws, regulations, orders, and requirements, including without limitation those of the United States and the European Union, and the jurisdictions in which the Seller and the Buyer are established or from which Goods may be supplied, will apply to their receipt and use. In no event shall Buyer use, transfer, release, import, or export Goods in violation of such applicable laws, regulations, orders or requirements.

19. **HIRING/EMPLOYEES:** Buyer agrees that during the execution of Services by Seller and for a period of twelve (12) months after the performance of Services, it will not hire any employee(s) of Seller and will not entice or counsel any such employee(s) to leave Seller's employ. Buyer agrees that this covenant shall extend to its agents and affiliates. In the event that an employee of Seller is hired or leaves the employ of Seller in such circumstances, Buyer shall pay Seller, as compensation for the cost incurred by Seller in recruiting and training the employee, the sum equivalent to six (6) months pay for each employee hired from or leaving the employment of Seller.

20. **EMPLOYEE SAFETY AND SUSPENSION OF SERVICES:** Seller may suspend or terminate Services, at its sole discretion, without liability to Buyer if Buyer fails to meet its obligations hereunder or becomes bankrupt or insolvent or if Seller determines that continuing to provide Services represents a hazardous condition for its employees.

21. **MISCELLANEOUS:** These terms and conditions set forth the entire understanding and agreement between Seller and Buyer, and supersede all other communications, negotiations and prior oral or written statements regarding the subject matter of these terms and conditions. No change, modification, rescission, discharge, abandonment, or waiver of these terms and conditions of Sale shall be binding upon the Seller unless made in writing and signed on its behalf by an officer of the Seller. No conditions, usage or trade, course of dealing or performance, understanding or agreement purporting to modify, vary, explain, or supplement these Terms and Conditions shall be binding unless hereafter made in writing and signed by the party to be bound, and no modification shall be affected by the acceptance of purchase orders or shipping instruction forms containing terms at variance with or in addition to those set forth herein. Any such modifications or additional terms are specifically rejected by Seller. No waiver by Seller with respect to any breach or default or any right or remedy and no course of dealing, shall be deemed to constitute a continuing waiver of any other breach or default or of any other right or remedy, unless such waiver be expressed in writing and signed by the party to be bound. Seller is not responsible for typographical or clerical errors made in any quotation, orders or publications. All such errors are subject to correction. The validity, performance, and all other matters relating to the interpretation and effect of this contract shall be governed by the law of the state of New York. The United Nations Convention on the International Sale of Goods shall not apply to any transaction hereunder.





**Browning**<sup>®</sup>

**Regal Rexnord**

Customer Service: 800-626-2120

Technical Service: 800-626-2093

[CustomerService.PTSolutions@regalrexnord.com](mailto:CustomerService.PTSolutions@regalrexnord.com)

[regalrexnord.com](http://regalrexnord.com)

The proper selection and application of products and components, including assuring that the product is safe for its intended use, are the responsibility of the customer. To view our Application Considerations, please visit <https://www.regalrexnord.com/Application-Considerations>.

To view our Standard Terms and Conditions of Sale, please visit <https://www.regalrexnord.com/Terms-and-Conditions-of-Sale> (which may redirect to other website locations based on product family).

"Regal Rexnord" is not indicative of legal entity. Refer to product purchase documentation for the applicable legal entity.

Regal Rexnord, Browning Split Taper, B5V, Edge, Gearbelt, Gripbelt, Griptwist, MVP, Q-D and Tenso-Set are trademarks of Regal Rexnord Corporation or one of its affiliated companies.

© 2018, 2024 Regal Rexnord Corporation, All Rights Reserved. MCC23038E • Form# 8972E

**RegalRexnord**<sup>™</sup>