



Bray COMMERCIAL



24-10952-9, Rev. -

Bray Controls Commercial Division
13788 West Road, Suite 200A
Houston, Texas 77041

BCDSales@Bray.com
Phone: 1-888-412-2729
Fax: 1-888-412-2720
www.braycommercialdivision.com

5
Year
Warranty

VAM24-90-(A) Series — *Installation Instructions/Part Number 24-10952-9, Rev. — 06/22/20*

Application

The VAM24-90 Series Electric Non-Spring Return Actuators are direct mount actuators for the ST2 valve series and provide 90 lb·in (10 N·m) rated torque.

The series provides Automatic Signal Input Detection, which allows automatic recognition of input signals for on/off, floating, and modulating control. An optional line voltage auxiliary switch kit can be field-installed to indicate an end-stop position or perform switching functions within the selected rotation range.

The VAM24-90 actuators also feature an optional NEMA 4X weathershield (model # M9000-342) for applications in harsh environments.

IMPORTANT: Use the VAM24-90 Series Electric Non-Spring Return Valve Actuator only to control equipment under normal operating conditions. Where failure or malfunction of the electric actuator could lead to personal injury or property damage to the controlled equipment or other property, additional precautions must be designed into the control system. Incorporate and maintain other devices, such as supervisory or alarm systems or safety or limit controls, intended to warn of or protect against failure or malfunction of the electric actuator.



Special Tool Needed

To install the actuator, use a digital voltmeter or a Commissioning Tool.



Dimensions

See Figure 2 for dimensions of the Non-Spring Return VAM24-90 Actuated ST2 Series Ball Valve with linkage. See Table 1 for specific model linkage dimensions.

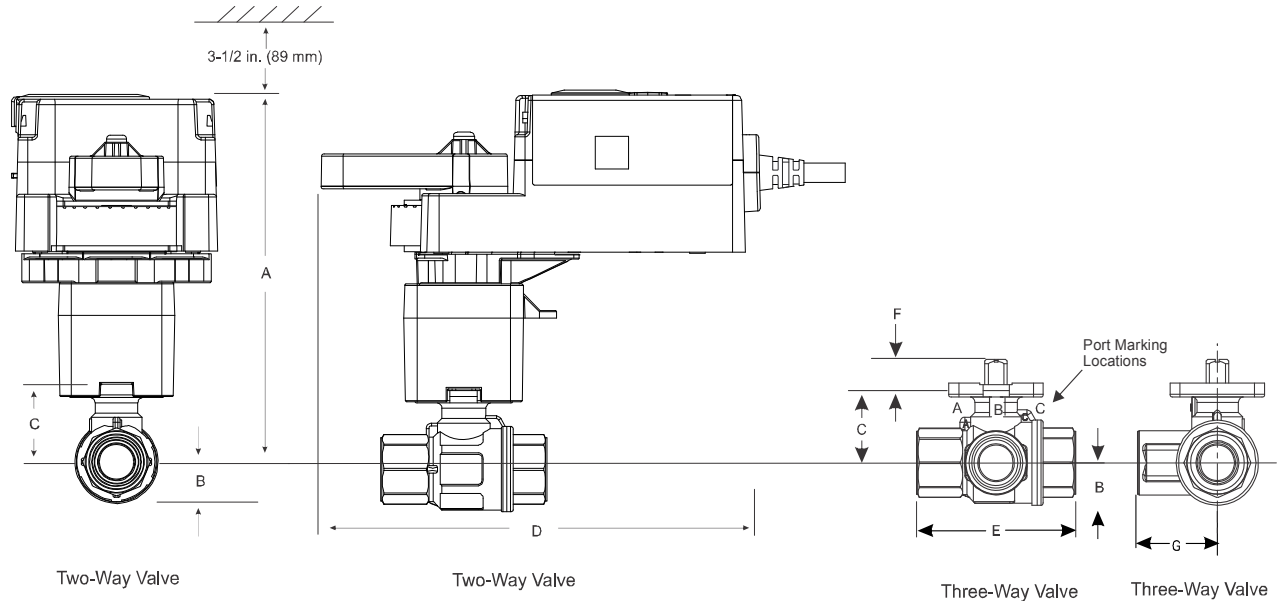

Figure 2: VAM24-90 Series Electric Non-Spring Return Actuator and Valve Dimensions (with ST2-HT Thermal Barrier)

Table 1: VAM24-90 Actuated ST2 Series Ball Valve Dimensions, in. (mm)

Valve Size, in. (DN)	A (With Thermal Barrier)	A (Without Thermal Barrier)	B	C	D	E	F	G
1/2 (DN15)	5-3/4 (146)	4-3/8 (111)	21/32 (17)	1-7/32 (31)	6-13/32 (163)	2-33/64 (64)	11/32 (9)	1-1/4 (32)
3/4 (DN20)	5-3/4 (146)	4-3/8 (111)	21/32 (17)	1-7/32 (31)	6-13/32 (163)	2-51/64 (71)	11/32 (9)	1-13/32 (36)
1 (DN25)	5-13/16 (148)	4-7/16 (113)	3/4 (19)	1-5/16 (33)	6-13/32 (163)	3-13/32 (87)	11/32 (9)	1-45/64 (43)
1-1/4 (DN32)	6-1/4 (159)	4-7/8 (124)	1-1/32 (26)	1-23/32 (44)	6-13/32 (163)	3-15/16 (100)	11/32 (9)	1-31/32 (50)
1-1/2 (DN40)	6-13/32 (163)	5-1/32 (128)	1-1/8 (29)	1-7/8 (48)	6-13/32 (163)	4-21/64 (110)	11/32 (9)	2-11/64 (55)
2 (DN50)	6-5/8 (168)	5-1/4 (133)	1-15/32 (37)	2-1/16 (53)	6-13/32 (163)	4-27/32 (123)	11/32 (9)	2-27/64 (62)



Mounting

You can mount the VAM24-90 Series actuator directly to the valve for preferred performance or with the ST2-HT thermal barrier when high-temperature fluid is used or additional spacing for insulation is needed.

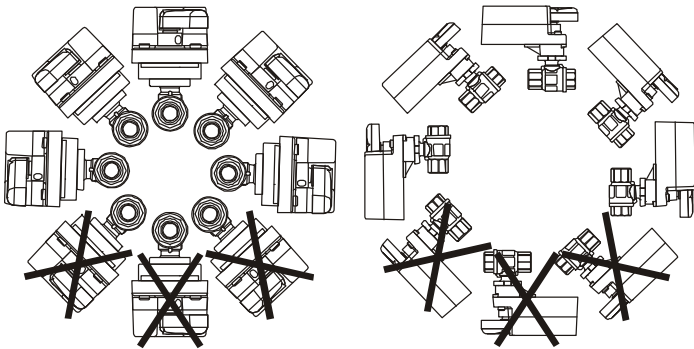
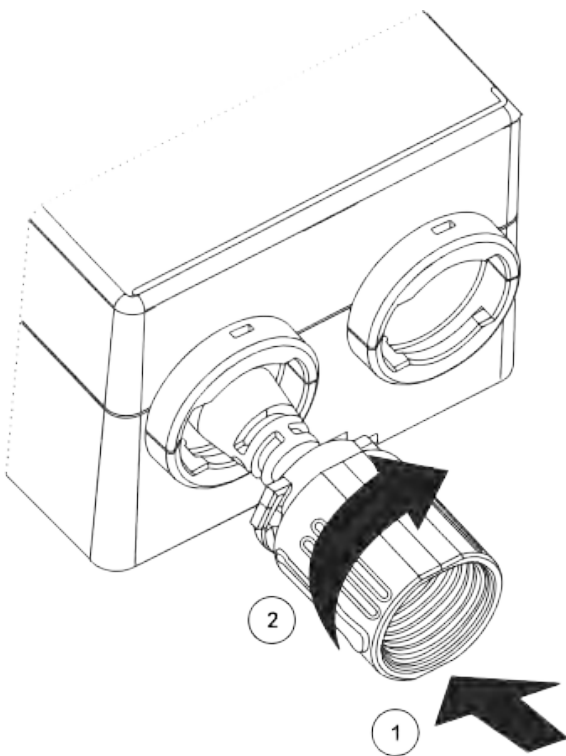

Figure 2: Mounting Positions

Installing the Conduit Connector

1. Slide the connector onto the actuator.



2. Turn the connector and lock it into position.

Mounting the Actuator Inline to the Valve

1. Make sure the valve stem is inline to the valve openings.

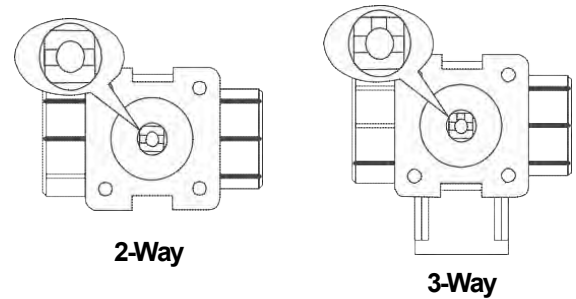

Figure 3: Positioning the Valve Stem

2. Verify that the actuator handle is inline to the actuator.
3. Place the actuator inline into the valve.
4. Tighten the actuator handle to the valve. The recommended torque is 8 to 12 lb·in (0.9 to 1.4 N·m).

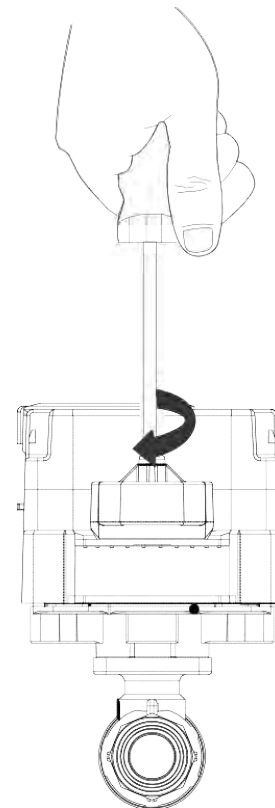

Figure 4: Tightening the Actuator Handle



Mounting the Actuator Perpendicular to the Valve

Note: If the actuator and valve arrive separately, proceed to Step 3.

1. Loosen but do not remove the screw that holds the actuator to the valve.

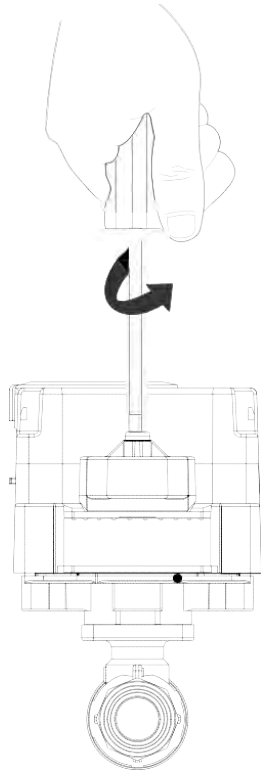

Figure 5: Loosening the Actuator Handle

2. Remove the actuator from the valve.
3. Press and hold the gear release. The actuator is against the internal counterclockwise (CCW) stop.
4. Lift the handle out of the actuator and rotate 90° CCW.

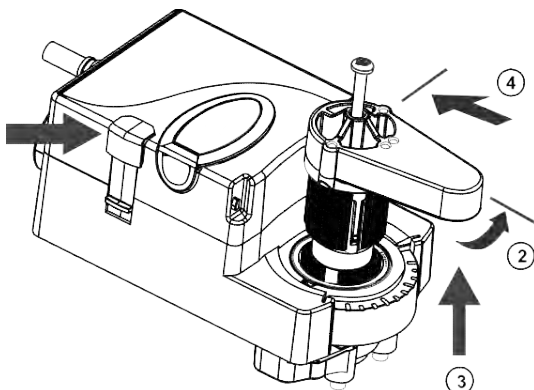

Figure 6: Press the Gear Release and Reposition the Handle

5. Reinsert the handle perpendicular into the actuator and tighten the handle screw. The installation torque is 8 to 12 lb·in (0.9 to 1.4 N·m).

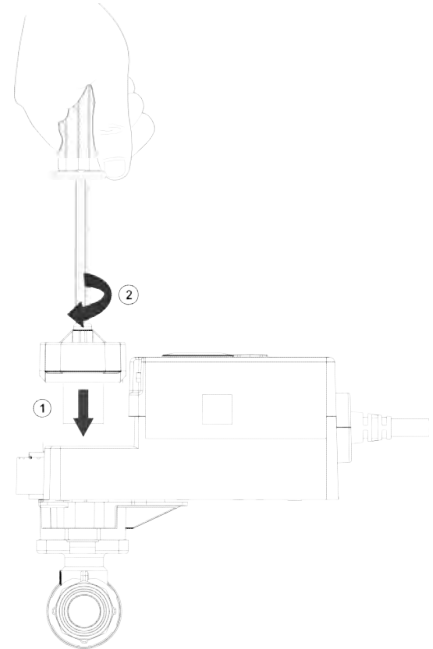

Figure 8: Tightening the Actuator Handle

Auto Calibration Mode

The actuator enters auto calibration mode and positions the valve shaft to the maximum and minimum end stops to identify the range of travel.

Accessing the DIP Switches and LEDs

Locate the oval cover on the front of the unit and pull the cover outward.

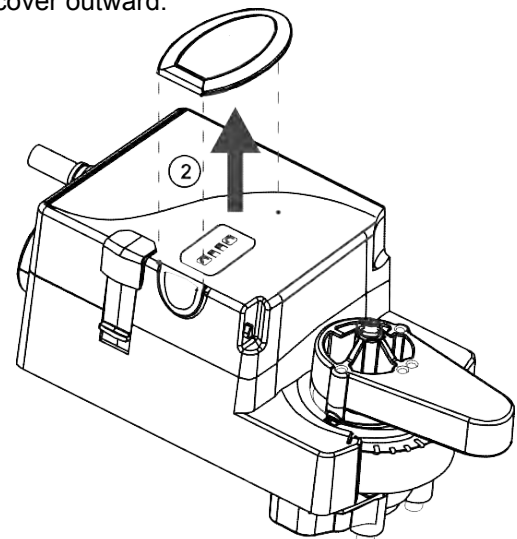

Figure 13: DIP Switch and LED cover



To complete the auto calibration process, press **Enter/Autocal** until all three LEDs are on. See Figure 14 for viewing the DIP switches and LEDs.

Operation

NOTICE

Risk of Property Damage.

Do not apply power to the system before checking all wiring connections. Short circuited or improperly connected wires may result in permanent damage to the equipment.

The valid Offset values are 0 to 10 VDC, and the valid Span values are 2 to 10 VDC. The maximum feedback voltage of the actuator is 10 VDC.

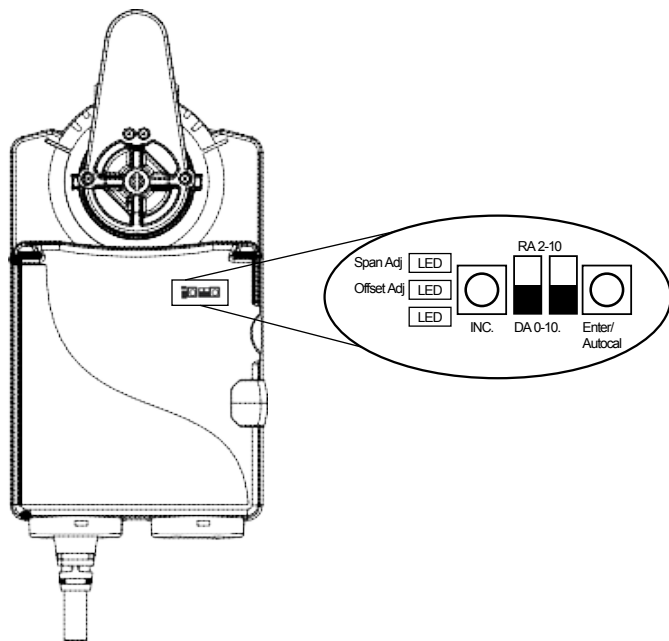

Figure 14: DIP Switches and LEDs Placement

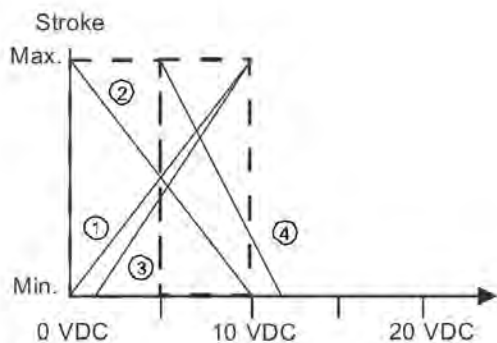

Figure 15: Graphed Examples of Table 3 Command Signals

Table 3: DIP Switch Settings

Example	Command Signal	Feedback Signal	Settings VAM24-90 User Interface
1	0 to 10 VDC	Direct 2 to 10 VDC	
2	0 to 10 VDC	Reverse 2 to 10 VDC	
3	2 to 10 VDC 24 VAC	Direct 2 to 10 VDC -	
4	Offset = 5 Span = 7	Reverse 2 to 10 VDC	

WARNING

Risk of Electric Shock.

Do not touch any exposed metal parts with anything other than properly insulated tools or insulated probes of the digital voltage meter. Failure to use properly insulated tools and probes may result in severe personal injury or death.

Setting the SPAN and OFFSET Modulating Command Signal to Other Values

1. Set DIP switch one and two before proceeding. See Figure 14 for DIP switch placement.
2. Connect a digital multimeter between the orange (feedback) and black (common) wires. See Wiring for more wiring information.
3. Press **Enter/Autocal**.

To adjust the span and offset, press but do not hold **Enter/Autocal**. Holding **Enter/Autocal** for longer than 3 seconds triggers an autocal.

The Offset Adj. LED turns on, and the multimeter displays the current offset value.



4. Press **INC.**.

The Offset Adj. LED flashes. The voltage reading on the multimeter increases 0.5 VDC each time you press the button. Press **INC.** until you reach the desired voltage.

If no further action is required, the Offset Adj. LED stops flashing after 10 seconds. The actuator exits the program mode, and the original offset value remains unchanged.

5. Press **Enter/Autocal.**

The Offset Adj. LED turns off indicating that the desired Offset Adj. value was recorded. The Span Adj. turns on, and the multimeter displays the present SPAN value.

6. Press **INC.**.

The Span Adj. LED flashes. The voltage reading on the multimeter increases by 0.5 VDC each time you press the button. Press **INC.** until you reach the desired voltage.

If no further action is required, the Offset and Adj. LED stops flashing after 10 seconds. The actuator exits the program mode, and the original offset value remains unchanged.

7. Press **Enter/Autocal.**

The Span Adj. LED turns off indicating that the desired Span Adj. setting is saved, and the actuator exits the program mode.

Reading the SPAN and OFFSET Modulating Command Signal Voltage Settings

1. Connect a digital multimeter between the orange (feedback) and black (common) wires. See Wiring for more wiring information.

2. Press **Enter/Autocal.**

The Offset Adj. LED turns on, and the multimeter displays the current offset value.

IMPORTANT: Do not press INC.; otherwise your observed offset voltage setting changes.

3. Press **Enter/Autocal.**

The Offset Adj. LED turns off, the Span Adj. LED turns on, and the multimeter displays the present SPAN value.

IMPORTANT: Do not press INC.; otherwise your observed SPAN voltage setting changes.

3. Press **Enter/Autocal.**

The Span Adj. LED turns off.

Clearing the SPAN and OFFSET Modulating Command Signal Voltage Setting

Cycle DIP switch two between 2 to 10 and 0 to 10. The active setting is the final state of DIP switch two.

Repositioning the Actuator Hub

1. De-energize the actuator.
2. Press the black manual override button on the side of the housing.

IMPORTANT: The manual override is automatically released when the button is released.

3. Rotate the tab to the desired position.

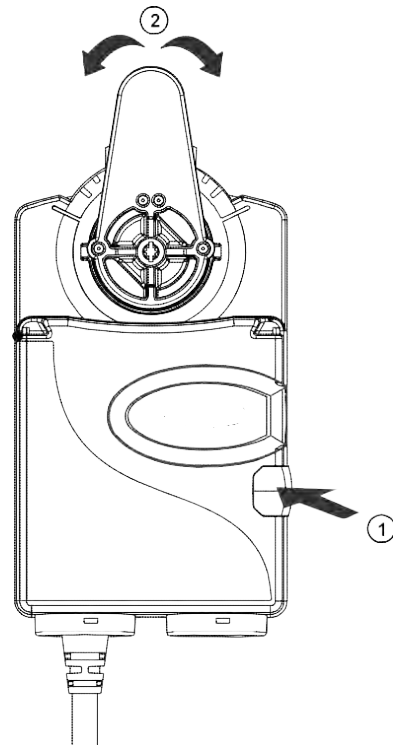

Figure 16: Override Button



Installing the Cover over the DIP Switches and LEDs

IMPORTANT: Once you have verified the DIP switch placement and LED activity, place the oval cover back onto the unit before repositioning the actuator hub.

Wiring

On/Off

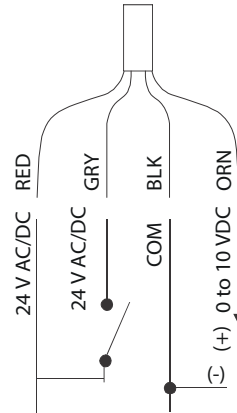

Floating

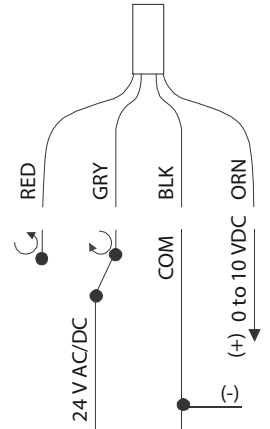

Modulating

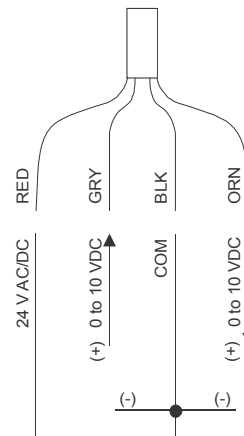

Modulating w/ 0(4) 20mA
External Resistor

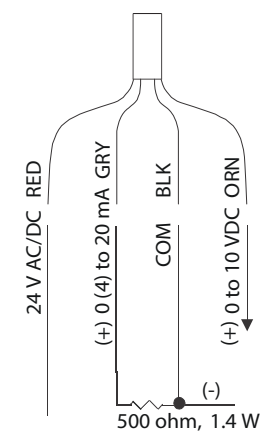

WARNING: All VAM24-90 Series actuators are designed for use only in conjunction with operating controls. Where an operating control failure would result in personal injury and/or loss of property, it is the responsibility of the installer to add safety devices or alarm systems that protect against, and/or warn of, control failure.

The performance specifications are nominal and conform to acceptable industry standards. For application at conditions beyond these specifications, consult the nearest Bray office. Bray controls shall not be liable for damages resulting from misapplication or misuse of its products.