



5
Year
Warranty

D(M)S24-180 Series — Installation Instructions

04/24/15

Applications

The D(M)S24-180 Series Electric Actuators are direct-mount, spring return electric actuators that operate on AC/DC 24V power. These bidirectional actuators do not require a damper linkage, and are easily installed on dampers with 1/2 to 3/4 in. or 12 to 19 mm round shafts, or 3/8 and 1/2 in. or 10, 12, and 14 mm square shafts using the standard shaft clamp included with the actuator. An optional M9220-600 Jackshaft Coupler Kit is available for 3/4 to 1-1/16 in. or 19 to 27 mm round shafts, or 5/8 and 3/4 in. or 16, 18, and 19 mm square shafts.

A single D(M)S24-180 Series Electric Spring Return Actuator provides a running and spring return torque of 177 lb·in (20 N·m). Two or three like models mounted in tandem deliver twice or triple the torque (354 lb·in [40 N·m] or 531 lb·in [60 N·m]). Integral line voltage auxiliary switches are available on the -A models to indicate end-stop position or to perform switching functions within the selected rotation range.

IMPORTANT: Use this D(M)S24-180 Series Electric Spring Return Actuator only to control equipment under normal operating conditions. Where failure or malfunction of the electric actuator could lead to personal injury or property damage to the controlled equipment or other property, additional precautions must be designed into the control system. Incorporate and maintain other devices such as supervisory or alarm systems or safety or limit controls intended to warn of, or protect against, failure or malfunction of the electric actuator.

Installation

The D(M)S24-180 Series Electric Spring Return Actuators mount directly to the surface in any convenient orientation using two M3 x 9.5 mm self-drilling sheet metal screws and the anti-rotation bracket (parts included with the actuator). No additional linkages or couplers are required. Electrical connections are color-coded and identified with numbers permanently marked on the actuator cable. A tag on the actuator cable identifies the electrical connections, and wiring details are also included on the actuator housing.

IMPORTANT: Do not install or use this D(M)S24-180 Series Electric Spring Return Actuator in or near environments where corrosive substances or vapors could be present. Exposure of the electric actuator to corrosive environments may damage the internal components of the device, and will void the warranty.

Parts Included

- actuator with coupler
- anti-rotation bracket
- manual override crank
- two M3 x 9.5 mm self-drilling sheet metal mounting screws
- two No. 10-32 x 9/16 in. thread-forming conduit screws

Special Tools Needed

- torque wrench with 3/8 in. (10 mm) socket
- digital voltmeter
- flat blade screwdriver



Dimensions

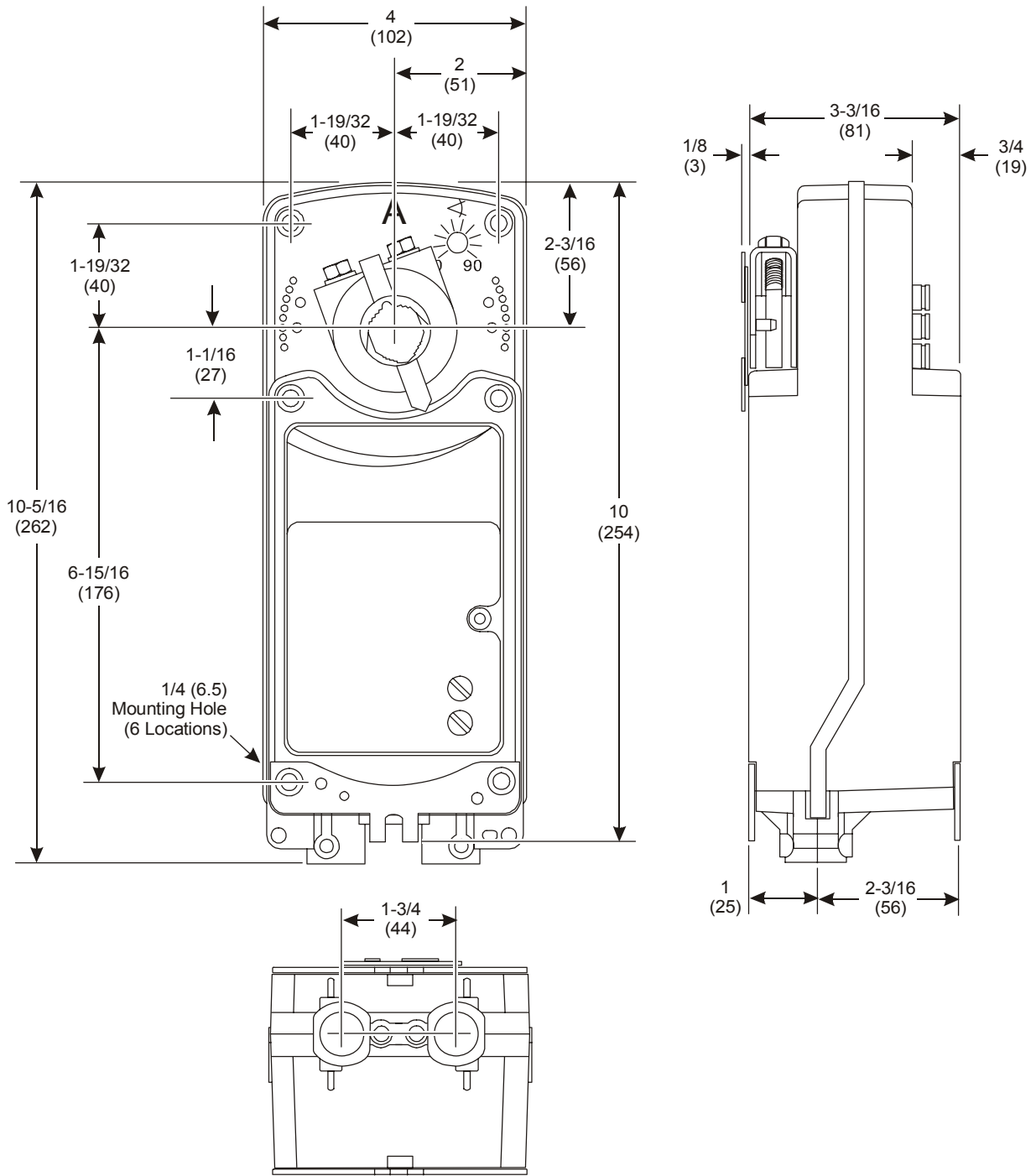

Figure 1: D(M)S-180 Series Electric Spring Return Actuator Dimensions, in. (mm)



5
Year
Warranty

Accessories

Table 1: Accessories and Replacement Parts (Order Separately)

Code Number	Description
DMPR-KC003¹	7 in. (178 mm) Blade Pin Extension (without Bracket) for Direct-Mount Damper Applications
M9000-153	Crank arm
M9000-158	Tandem Mounting Kit used to Mount Two Models of D(M)S24-180 Series Electric Spring Return Actuators
M9000-170	Remote Mounting Kit, Horizontal. Kit includes Mounting Bracket, M9000-153 Crank Arm, Ball ϕ int, and Mounting Bolts
M9000-171	Remote Mounting Kit, Vertical. Kit includes Mounting Bracket, M9000-153 Crank Arm, Ball ϕ int, and Mounting Bolts
M9000-604	Replacement Anti-rotation Bracket Kit (with Screws) for DMS24-180 Series Modulating Electric Spring Return Actuators
M9220-600	1 in. (25 mm) Jackshaft Coupler Kit (with Locking Clip) for Mounting D(M)S24-180 Series Electric Spring Return Actuators on Dampers with 3/4 to 1-1/16 in. or 19 to 27 mm Round Shafts, or 5/8 and 3/4 in. or 16, 18, and 19 mm Square Shafts
M9220-601	Replacement Coupler Kit (with Locking Clip) for Mounting D(M)S24-180 Series Electric Spring Return Actuators on Dampers with 1/2 to 3/4 in. or 12 to 19 mm Round Shafts, or 3/8 and 1/2 in. or 10, 12, and 14 mm Square Shafts
M9220-602	Replacement Locking Clips for D(M)S24-180 Series Electric Spring Return Actuators (Five per Bag)
M9220-603	Adjustable Stop Kit for D(M)S24-180 Series Electric Spring Return Actuators
M9220-604	Replacement Manual Override Cranks for the D(M)S24-180 Series Electric Spring Return Actuators (Five per Bag)
M9220-610	Replacement Shaft Gripper, 10 mm Square Shaft with Locking Clip
M9220-612	Replacement Shaft Gripper, 12 mm Square Shaft with Locking Clip
M9220-614	Replacement Shaft Gripper, 14 mm Square Shaft with Locking Clip

1. Furnished with the damper and may be ordered separately.

Mounting

The D(M)S24-180 Series Electric Spring Return Actuators can be easily installed on dampers with 1/2 to 3/4 in. or 12 to 19 mm round shafts, or 3/8 and 1/2 in. or 10, 12, and 14 mm square shafts. An M9220-600 Jackshaft Coupler Kit is available for 3/4 to 1-1/16 in. or 19 to 27 mm round shafts, or 5/8 and 3/4 in. or 16, 18, and 19 mm square shafts; see Table 1 for more details. If the damper shaft extends less than 3-19/32 in. (91 mm), see the *Removable Coupler* section for further instructions. If the damper shaft extends less than 1-5/32 in. (29 mm), install an extension recommended by the damper manufacturer.

Counterclockwise (CCW) Spring Return Direction – Clockwise (CW) Powered Operation

For CCW spring return direction, mount the actuator to the damper shaft so that Side A of the actuator is away from the damper as illustrated in Figure 2. With power applied, the actuator drives CW from the 0° position, and spring returns CCW.

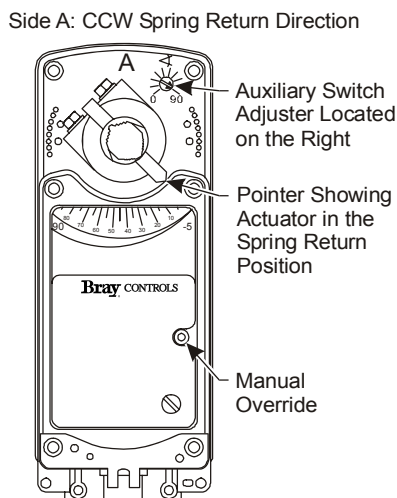

Figure 2: Side A of Actuator

Clockwise (CW) Spring Return Direction – Counterclockwise (CCW) Powered Operation

To change the spring return direction to CW, mount the actuator to the damper shaft so that Side B of the actuator is away from the damper as illustrated in Figure 3. With power applied, the actuator now drives CCW from the 0° position, and spring returns CW.

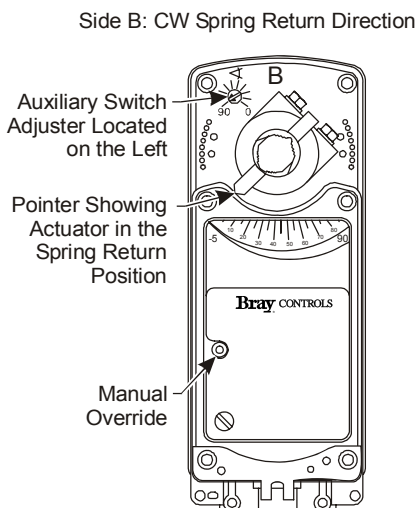

Figure 3: Side B of Actuator

Removable Coupler

The coupler may be installed on either side of the output hub. If the damper shaft is less than 3-19/32 in. (91 mm) long, insert the coupler in the face of the actuator closest to the damper. If the damper shaft is shorter than 1-5/32 in. (29 mm) long, a shaft extension is required to mount the actuator.

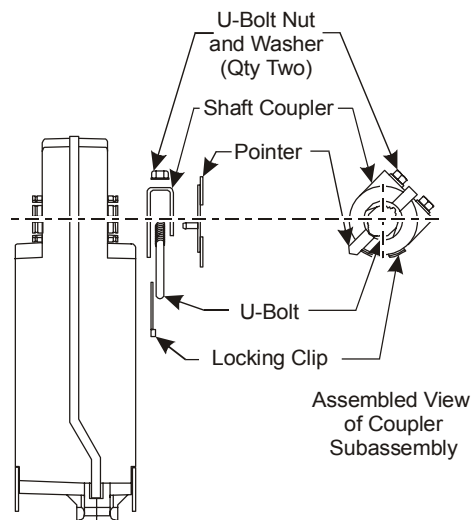

Figure 4: Changing the Position of the Coupler

To change the position of the coupler, see Figure 4 and proceed as follows:

1. Mount the coupler on either Side A or Side B of the actuator, as determined by the shaft length.
2. Snap the locking clip securely into the coupler retention groove to retain the coupler.

Manual Override

Use only the supplied manual override crank to reposition the actuator hub when using the manual override feature.

IMPORTANT: Applying excessive torque to the manual override or running the manual override with a power tool may damage the internal components of the actuator and cause premature failure.

To reposition the actuator hub, proceed as follows:

1. De-energize the actuator.
2. Insert the hex end of the manual override crank into the manual override adjustment point on the face of the actuator.
3. Rotate the manual override crank in the direction indicated by the arrow on the label.



Note: The actuator requires 27 rotations of the manual override crank from the fully spring return position to fully reposition the actuator hub. At the end of travel, the rotational resistance increases; do not force the actuator hub past this point.

- Rotate the manual override crank a half turn in the opposite direction to lock the actuator hub in place.

Note: To unlock the actuator hub, rotate the manual override crank in the direction indicated by the arrow on the label. The actuator hub automatically unlocks when power is applied to the actuator, and returns the actuator to normal drive and spring return operation.

Mounting the Actuator

To mount the actuator, proceed as follows:

- See the dimensions in Figure 5 and Table 2 to ensure the correct positioning of the anti-rotation bracket.

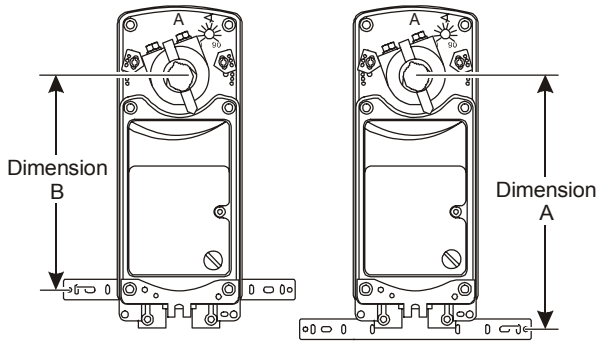

Figure 5: Positioning the Anti-Rotation Bracket

Table 2: Dimensions from Anti-rotation Bracket to Shaft Center

Shaft Diameter	Dimension A, in. (mm)	Dimension B, in. (mm)
1/2 to 9/16 in. (12 to 14 mm)	8-9/32 (210)	7 (178)
5/8 to 3/4 in. (16 to 19 mm)	8-5/32 (207)	6-29/32 (175)

IMPORTANT: The tab on the anti-rotation bracket must fit midpoint in the actuator slot. Positioning the tab midpoint in the slot prevents actuator binding and premature wear, and makes actuator removal easier.

- Bend or cut the anti-rotation bracket to fit the damper frame or duct as illustrated in Figure 6.

Note: You can bend the anti-rotation bracket to fit a round damper.

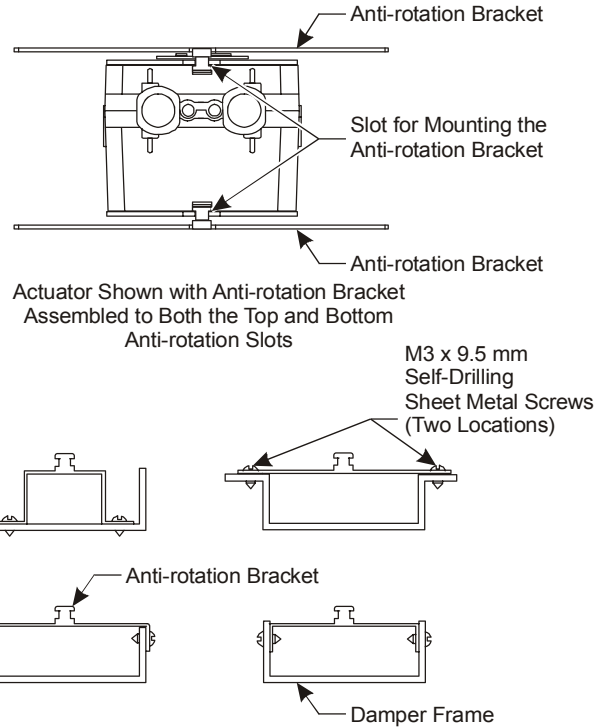

Figure 6: Fitting the Anti-Rotation Bracket on the Damper Frame or Duct

- Drill mounting holes in the damper frame or duct using the anti-rotation bracket as a guide (based on the measurements obtained in Table 2 and Figure 5).
- Secure the anti-rotation bracket to the damper frame or duct using the two M3 x 9.5 mm self-drilling sheet metal screws provided and a 1/4 in. (6 mm) blade screwdriver or 5/16 in. (8 mm) nut driver.

IMPORTANT: Do not overtighten the mounting screws to avoid stripping the threads. Be certain that the tab on the anti-rotation bracket remains properly positioned in the slot on the actuator, and that the actuator remains parallel to the mounting surface.

- Slide the actuator onto the damper shaft, and position the tab of the anti-rotation bracket into the slot at the bottom of the actuator as illustrated in Figure 6.



6. Rotate the damper blades to the desired position if the power is lost. To ensure a tight seal, insert the manual override crank and turn it in the direction indicated by the arrow on the label five turns; the position indicator should be near the 0° position on the scale. Quickly rotate the manual override crank a half turn in the opposite direction to temporarily lock the actuator hub in place.
7. Evenly hand tighten each clamp nut onto the U-bolt, keeping the actuator flat. Secure the U-bolt to the damper shaft and tighten to a torque of 100 to 125 lb-in (11 to 14 N·m).
8. To release the spring, turn the manual override crank in the direction indicated on the label; the actuator spring returns to its starting position. If this step is omitted, the spring releases automatically when power is applied to the actuator.
9. Remove the manual override crank and store it in an unused mounting hole.
10. Apply power long enough for the actuator to travel a full stroke, and verify that the actuator rotates freely throughout the range.

Note: If electric power is not available, complete this verification by reinserting the manual override crank and turning it in the direction indicated to rotate the coupler to the fully open position.

Rotation Range Using Optional M9220-603 Adjustable Stop Kit

The actuator is factory set for 90° rotation, and its rotation range is limited in 5° increments to a minimum of 30°. Stroke limiting stops are attached in the field to the shaft coupler side of the actuator to reduce the rotation range. Attaching a stroke limiting stop in the furthest mounting position reduces the rotation range of the actuator by 5°. Each progressive mounting position reduces the rotation range an additional 5°.

1. Check that the damper blade is accessible or that its position is permanently marked on the end of the damper shaft as illustrated in Figure 7.

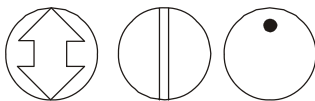

Figure 7: Damper Position Icons

2. Determine the desired rotation range. If a 65 to 90° rotation range is desired, add one stroke limiting stop. If a 35 to 60° rotation range is desired, add two stroke limiting stops.

Note: If two stroke limiting stops are applied, use the manual override crank to position and lock the actuator in a mid-stroke position to gain access to both stroke limiting stop mounting positions.

3. Mount the stroke limiting stops in the desired position using the two M4 x 10 mm self-tapping screws provided. Tighten the screws to a torque of 35 lb-in (4 N·m).
4. Manually reposition the coupler so that the coupler set screw aligns with the nodule guide that corresponds to the value determined in Step 2.

Example:

For a rotation range of 65°, mount one stroke limiting stop in the minimum stroke position as illustrated in Figure 8.

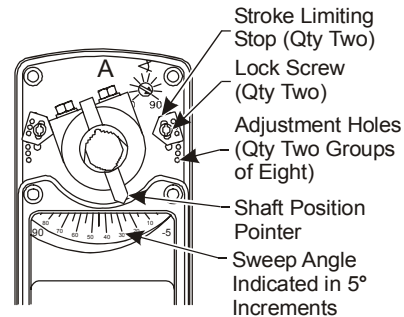

Figure 8: One Stroke Limiting Stop Mounted in the Minimum Stroke Position for a Rotation Range of 65°



Wiring

The DS24-180 Series On/Off Electric Spring Return Actuator provides reliable, integrated damper control. An AC 24 V at 50/60 Hz or DC 24 V input signal between the black and red wires, or an AC 120 V input signal at 60 Hz between the black and white wires, or an AC 230 V input signal at 50/60 Hz between the blue and brown wires causes the output hub to rotate from -5 to 90° (unless an external mechanical limit is reached.)

Once the command to rotate is removed, the actuator spring returns to its -5° position (unless an external mechanical limit is reached). A stall condition while driving between -5 to 90° causes the output hub to stop motion and hold its position until power is removed. Rotation is mechanically limited to the -5 and 90° positions by integral end-stops. Optional end-stops are available to limit the output hub travel. An anti-rotation bracket prevents rotational movement of the actuator body.

See Figure 9 and Figure 10 for proper wiring of the DS24-180 Series On/Off Electric Spring Return Actuator.

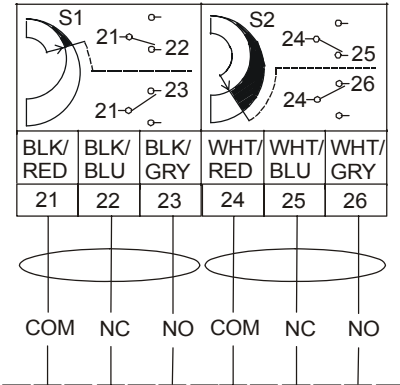

Figure 9: Auxiliary Switch Wiring Diagram for -A Models

- CAUTION: Risk of Electric Shock.**
Disconnect the power supply before making electrical connections to avoid electric shock.
- CAUTION: Risk of Property Damage.**
Do not apply power to the system before checking all wiring connections. Short circuited or improperly connected wires may result in permanent damage to the equipment.
- IMPORTANT:** Make all wiring connections in accordance with local, national, and regional regulations. Do not exceed the electrical ratings of the DS24-180 Series On/Off Electric Spring Return Actuator.

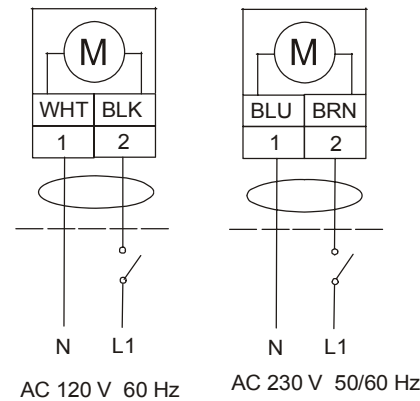
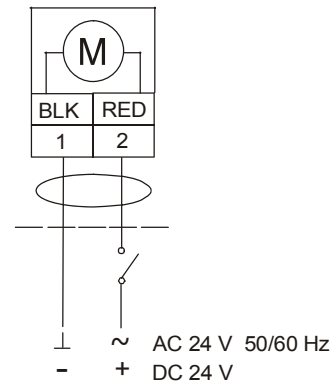

Figure 10: Control Wiring Diagrams



Wiring

The DS24-180-T Floating Electric Spring Return Actuator provides reliable, integrated damper control. When 24 VAC at 50/60 Hz or 24 VDC power is applied between the black and red wires, and power is applied to a gray or orange control wire, the output hub rotates from -5 to 90°, based on the Reverse Acting (RA)/Direct Acting (DA) setting (unless an external mechanical limit is reached).

Once the command to rotate is removed, the actuator holds its position, until either another command to rotate is applied or until all power is removed. When power is removed, the actuator spring returns to its -5° position (unless an external mechanical limit is reached). A stall condition while driving between -5 to 90° causes the output hub to stop motion and hold its position until power is removed. Rotation is mechanically limited to the -5 and 90° positions by integral end-stops. Optional end-stops are available to limit the output hub travel. An anti-rotation bracket prevents rotational movement of the actuator body.

See Figure 11 and Figure 12 for proper wiring of the DS24-180-T Floating Electric Spring Return Actuators.

CAUTION: Risk of Electric Shock.
 Disconnect the power supply before making electrical connections to avoid electric shock.

CAUTION: Risk of Property Damage.
 Do not apply power to the system before checking all wiring connections. Short circuited or improperly connected wires may result in permanent damage to the equipment.

IMPORTANT: Make all wiring connections in accordance with local, national, and regional regulations. Do not exceed the electrical ratings of the DS24-180-T Series Floating Electric Spring Return Actuator.

Floating Control, Four Wire

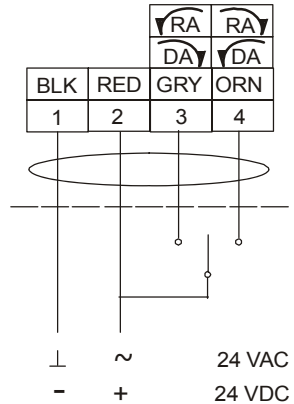

Open/Close, Single Wire Control

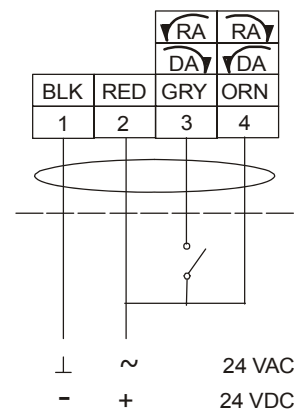

On/Off Control, Two Wire

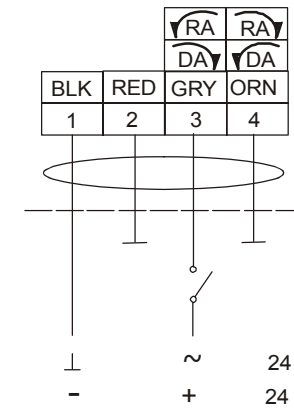

Figure 12: Control Wiring Diagrams

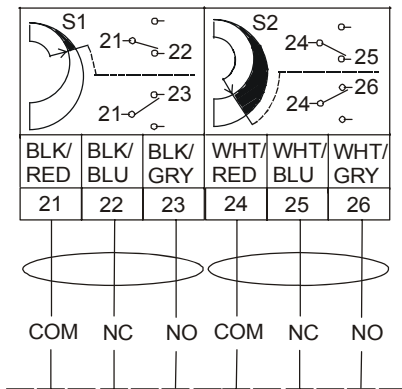

Figure 11: Auxiliary Switch Wiring Diagram for -TA Modles



Wiring

The DMS24-180 Series Electric Spring Return Actuator provides reliable, integrated damper control. An AC 24 V at 50/60 Hz or DC 24 V input signal between the black and red wires, and a DC 0(2) to 10 V input control signal, causes the output hub to rotate from -5 to 90° (unless an external mechanical limit is reached).

Once the actuator reaches the commanded position, it holds that position until power is removed. If power is removed, the actuator spring returns to its -5° position (unless an external mechanical limit is reached). A stall condition while driving between -5 to 90° causes the output hub to stop motion and hold its position until power is removed. Rotation is mechanically limited to the -5 and 90° positions by integral end-stops. Optional end-stops are available to limit the output hub travel. An anti-rotation bracket prevents rotational movement of the actuator body.

See Figure 13 and Figure 14 for proper wiring of the DMS24-180 Modulating Electric Spring Return Actuator.

CAUTION: Risk of Electric Shock.
Disconnect the power supply before making electrical connections to avoid electric shock.

CAUTION: Risk of Property Damage.
Do not apply power to the system before checking all wiring connections. Short circuited or improperly connected wires may result in permanent damage to the equipment.

IMPORTANT: Make all wiring connections in accordance with local, national, and regional regulations. Do not exceed the electrical ratings of the DMS24-180 Series Electric Spring Return Actuator.

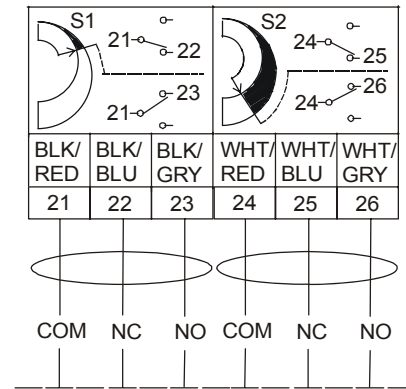

Figure 13 Auxiliary Switch Wiring Diagram for -A Modles

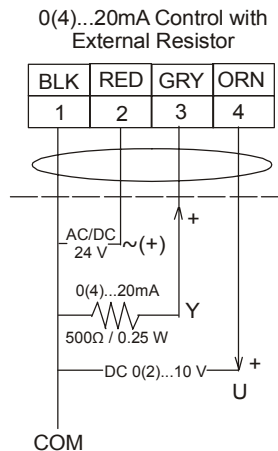
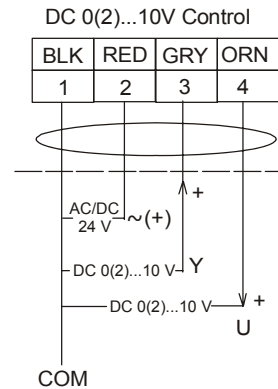

Figure 14: Control Wiring Diagrams



Setup and Adjustments

Direction of Action

The DMS24-180 Series Electric Spring Return Actuators are factory set for Direct Acting (DA) operation. In DA mode, applying an increasing input signal to the control input drives the actuator away from the spring return position. Reverse Acting (RA) operation is also available. In RA mode, applying an increasing input signal to the control input drives the actuator toward the spring return position. Figure 15 and Figure 16 indicate how the drive direction for the actuator depends on the spring return direction and the position of the mode selection switch.

Control Inputs			Mode Selection Switch Setting	
	CCW Face of Actuator	CW Face of Actuator	DA	RA
			RA	DA
	Increasing Signal	CW	CCW	CW
Decreasing Signal	CCW	CW	CCW	CW

Direction	Feedback	Rotation Position						
		0°*	15°	30°	45°	60°	75°	90°
Direct Acting	0-10V	0.0V	1.7V	3.3V	5.0V	6.7V	8.3V	10.0V
	2-10V	2.0V	3.3V	4.7V	6.0V	7.3V	8.7V	10.0V
Reverse Acting	0-10V	10.0V	8.3V	6.7V	5.0V	3.3V	1.7V	0.0V
	2-10V	10.0V	8.7V	7.3V	6.0V	4.7V	3.3V	2.0V

* 0° is the spring return position.

Figure 15: Nominal Feedback Signal Relative to Rotation Position

Mode Selector Switch and CAL Function

The DMS24-180 Series Electric Spring Return Actuators are factory set at Direct Acting (DA), DC 0 to 10 V control input (Figure 16). To change to RA operation, move the mode selection switch from DA to RA. The DC input signal is selectable from DC 0 to 10 V or from DC 2 to 10 V, which corresponds to 0 to 95° rotation. If the rotation range is reduced, the end-stop is reached with a reduced input signal. For example, if a DC 0 to 10 V input signal is selected and the rotation range is limited to 75°, the end-stop is reached at DC 8.3 V. If an external 500 ohm resistor is placed across the input (see Figure 10), the switch positions then select between 0-20 mA or 4-20 mA.

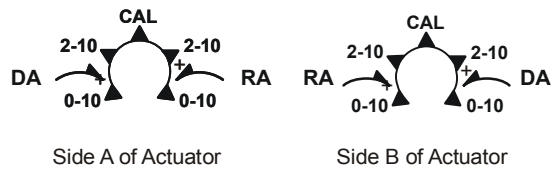

Figure 16: Mode Selection

The CAL function enables the actuator to redefine the selected control input range proportionally across a reduced rotation range. The actuator stores the reduced rotation range in nonvolatile memory (retains data when power is lost or removed).

To calibrate the control input range, proceed as follows:

1. With power off, move the mode selection switch to the CAL position (Figure 12). Then, energize the actuator. The actuator automatically rotates until the end-stops are found, and proportionally reconfigures the control input range to the reduced rotation range.

2. Return the mode selection switch to the desired selection (example: DA, 0 to 10 VDC control input).

Note: During normal operation, if the actuator stroke increases due to seal or seat wear, the input is redefined to the increased rotation range in approximately 0.5° increments.

3. If the actuator mounting position is changed or if the linkage is adjusted, repeat Steps 1 and 2 to reinitiate the CAL function.

Note: To repeat calibration with power applied, move the mode selection switch out of the CAL position for at least 2 seconds before returning it to the CAL position. Auto calibration begins 5 seconds after you return it to the CAL position.



**Tandem Operation:
Master with Slaves**

The tandem configuration (Figure 17 and Figure 19) provides twice (with two actuators) or triple (with three actuators) the running and spring return torque of a single actuator, or 354 lb·in (40 N·m), 531 lb·in (60 N·m). The actuators may be mounted in tandem using the M9000-158 Tandem Mounting Kit. To mount a third actuator, user-configured bracketing is required..

DC 0(2)...10V Control with Tandem Connection

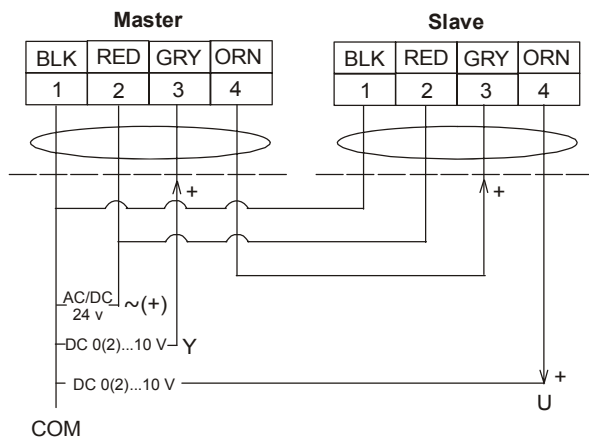

Figure 17: Tandem Connection

Follow these guidelines for tandem operation:

- Two or three DMS24-180 Series actuators may be operated in tandem on the same shaft. If mounting two actuators, see Figure 17; for three actuators, see Figure 19.
- Each actuator requires separate 24 volt power. When two or more actuators connected in tandem share a common power source, the total maximum power draw is actually 1.5 times the normal running current for each actuator. (Total Power = Number of Actuators x Running Power x 1.5).
- Only one of the actuators can be configured as the master. Set the selector switch to the master position (Figure 18).

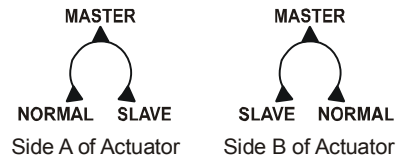

Figure 18: Tandem Selector Switch

- The other modulating actuator(s) **must** be configured as slave(s), by setting the tandem selector switch to the slave position.
- The master can accept DC 0-10 V or DC 2-10 V, or 4-20 mA command signals based on the master's switch settings and/or external resistor.
- The master and slave(s) must have matching RA/DA settings..

DC 0(2)...10V Control with Multiple Slaves

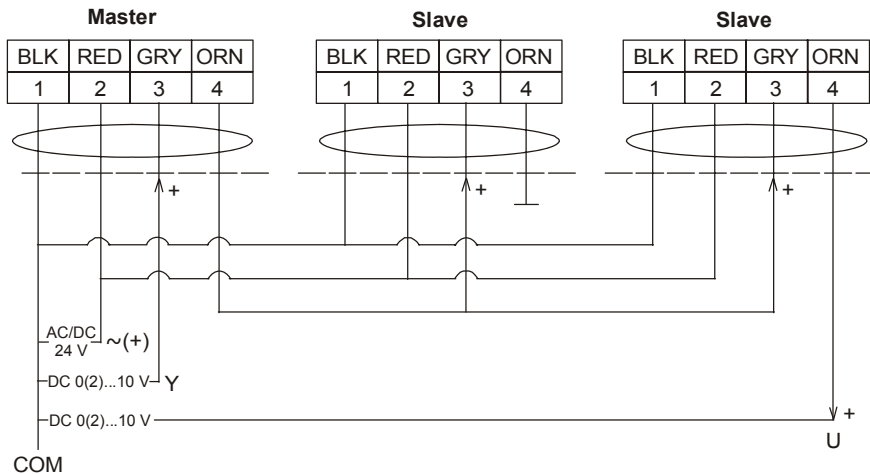

Figure 19: Tandem Connection with Three Actuators



5
Year
Warranty

- The master and slave(s) must spring return in the same direction.
- Once tandem-operating actuators are mounted to a damper shaft, manual override is no longer an available function.

The feedback wire of the master (orange) is connected to the command wire(s) of the slave(s)(gray). As the master moves response to position commands, the master sets its feedback wire to 0 volts if moving counterclockwise, 5 volts if holding, or 10 volts if moving clockwise.

Each slave actuator must have its tandem selector switch (Figure 18) set on the slave setting. Its gray command wire must be connected the master's orange feedback wire.

Position information, 0-10 (or 2-10) volts, is available on the slave actuator's feedback wire (orange).

Note: Electrical override still functions after the actuators configured for tandem operation are mounted to a damper shaft. The actuator has a 150-second drive time when operating in this mode

Auxiliary Switches (-A) Model Only

The (-A) models include two integral auxiliary switches with a switch adjuster accessible on either face of the actuator (as illustrated in Figure 2 and Figure 3). The nominal factory setting for Auxiliary Switch No. 1 is 11° closing, and the nominal factory setting for Auxiliary Switch No. 2 is 81° opening (relative to a 0 to 90° rotation range). See the *Technical Specifications* table for the auxiliary switch ratings.



WARNING: Risk of Electric Shock.

Disconnect each of multiple power supplies before making electrical connections. More than one disconnect may be required to completely de-energize equipment. Contact with components carrying hazardous voltage can cause electric shock and may result in severe personal injury or death.

The switch point of Auxiliary Switch No. 1 is fixed. The switch point of Auxiliary Switch No. 2 is independently and continuously adjustable from 25 to 95°. See Figure 20 and use the method in the following example for the most accurate positioning of Auxiliary Switch No. 2.

To change the switch point of Auxiliary Switch No. 2, proceed as follows:

1. Position the actuator in the full spring return position.

Note: Auxiliary Switch No. 2 is factory set to trip when the actuator reaches the 81° position.

2. Rotate the switch adjuster until it points to the desired switch point.

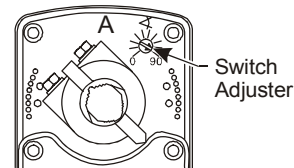

Figure 20: Switch Point Settings

3. Connect Auxiliary Switch No. 2 to a power source or an ohmmeter, and apply power to the actuator. The actuator moves to the fully open position and holds while power is applied.
4. Observe the switch point. If required, repeat Steps 2 and 3.

Repairs and Replacement

A number of replacement parts are available; see Table 1 for more details. If the DMS24-180 Proportional Electric Spring Return Actuator fails to operate within its specifications, replace the unit.



Setup and Adjustments

Direction of Action

The DS24-180-T Floating Electric Spring Return Actuators are factory set for Direct Acting (DA) operation but may also be switched to Reverse Acting (RA) operation. A control input drives the actuator.

Figure 21 and Figure 22 indicate how the drive direction for the actuator depends on the spring return direction and the position of the mode selection switch.

Control Inputs					
		CCW Face of Actuator		CW Face of Actuator	
Mode Selection Switch Setting					
GRY 3	ORN 4	DA	RA	RA	DA
CLOSED	OPEN	CW	CCW	CW	CCW
OPEN	CLOSED	CCW	CW	CCW	CW
OPEN	OPEN	Holds Position			
CLOSED	CLOSED	CW	CCW	CW	CCW

Figure 21: Settings for Drive Direction

Mode Selection Switch

The DS24-180-T Floating Electric Spring Return Actuators are factory set at DA, 90 degrees of travel as illustrated in Figure 22. To reverse the rotation, either move the mode selection switch from Direct Acting (DA) to Reverse Acting (RA), or reverse the control input wiring to GRY 3 and ORN 4.

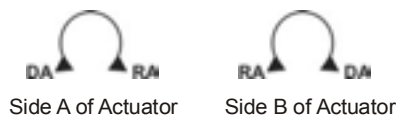

Figure 22: Mode Selection

Tandem Operation

The tandem configuration provides twice the running and spring return torque of a single actuator (354 lb-in [40 N·m]). Two similar actuators can be mounted in tandem using the Tandem Mounting Kit operate together.

Use two or three actuators from the same model type for tandem operation. Actuators used in the tandem configuration are wired in parallel (as illustrated in Figure 23).

Note: Manual override does not function after the actuators configured for tandem operation are mounted to a damper shaft.

Floating Control, Four Wire with Tandem Connection

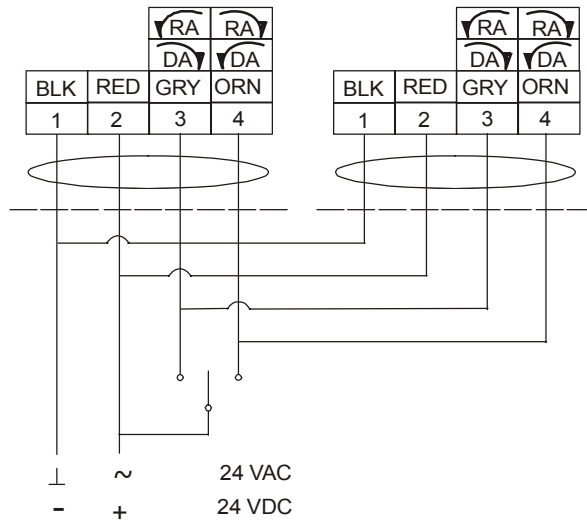

Figure 23: Tandem Connection

Auxiliary Switches (-A Models Only)

The -A models include two integral auxiliary switches with a switch adjuster accessible on either face of the actuator (as illustrated in Figure 2 and Figure 3). The nominal factory setting for Auxiliary Switch No. 1 is 11° closing, and the nominal factory setting for Auxiliary Switch No. 2 is 81° opening (relative to a 0 to 90° rotation range). See the *Technical Specifications* table for the auxiliary switch ratings.



WARNING: Risk of Electric Shock.

Disconnect each of multiple power supplies before making electrical connections. More than one disconnect may be required to completely de-energize equipment. Contact with components carrying hazardous voltage can cause electric shock and may result in severe personal injury or death.

The switch point of Auxiliary Switch No. 1 is fixed. The switch point of Auxiliary Switch No. 2 is independently and continuously adjustable from 25 to 95°. See Figure 24 and use the method in the following example for the most accurate positioning of Auxiliary Switch No. 2.

To change the switch point of Auxiliary Switch No. 2, proceed as follows:

1. Position the actuator in the full spring return position.

Note: Auxiliary Switch No. 2 is factory set to trip when the actuator reaches the 81° position.

2. Rotate the switch adjuster until it points to the desired switch point.

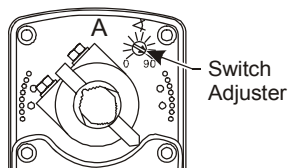

Figure 24: Switch Point Settings

3. Connect Auxiliary Switch No. 2 to a power source or an ohmmeter, and apply power to the actuator. The actuator moves to the fully open position and holds while power is applied.
4. Observe the switch point. If required, repeat Steps 2 and 3.

Repairs and Replacement

A number of replacement parts are available; see Table 1 for more details. If the floating D(M)S24-180 Series Electric Spring Return Actuator fails to operate within its specifications, replace the unit.