



D(M)24-35 Series — Installation Instructions

09/25/15

Applications

The D(M)24-35 Series Actuators are Non-Spring Return Electric Actuators that operate on AC 24 V power and use M3 screw terminals for field wiring. Employing a synchronous motor, these actuators provide floating control (-T), and modulating control with selectable 0-10 or 2-10 VDC (DM).

All models are compact in size, and are easily installed on Variable Air Volume (VAV) boxes, Variable Air Volume and Temperature (VVT) two-position zone applications, or small to medium-sized dampers with a round shaft up to 1/2 in. (13 mm) in diameter, or a 3/8 in. (10 mm) square shaft.

The D(M)24-35 Series Electric Non-Spring Return Actuators provide a running torque of 35 lb-in (4 N·m), and the nominal travel time is 60 seconds at 60 Hz (72 seconds at 50 Hz) for 90° of rotation.

Installation

For damper applications the D(M)24-35 Series Electric Non-Spring Return Actuators mount directly to the surface in any convenient orientation using a single No. 10 self-drilling sheet metal screw. No additional linkages or couplers are required. Electrical connections on the actuator are clearly labeled to simplify installation.

Parts Included

- one electric non-spring return actuator with M3 screw terminals for terminal strip option.

Special Tools Needed

- 5/16 in. (8 mm) square socket
- #2 Phillips screwdriver
- 3/8 in. (10 mm) 12-point socket
- drill with a 5/16 in. (8 mm) hex nut driver
- digital voltmeter or Commissioning Tool

IMPORTANT: Use this D(M)24-35 Series Electric Non-Spring Return Actuator only to control equipment under normal operating conditions. Where failure or malfunction of the actuator could lead to personal injury or property damage to the controlled equipment or other property, additional precautions must be designed into the control system. Incorporate and maintain other devices, such as supervisory or alarm systems or safety or limit controls, intended to warn of or protect against failure or malfunction of the actuator.

IMPORTANT: Before specifying D(M)24-35 Series Electric Non-Spring Return Actuators for plenum applications, verify acceptance of exposed plastic materials in plenum areas with the local building authority. Building codes for plenum requirements vary by location. Some local building authorities accept compliance to UL 1995, Heating and Cooling Equipment, while others use different acceptance criteria.

IMPORTANT: Do not install or use this D(M)24-35 Series Electric Non-Spring Return Actuator in or near environments where corrosive substances or vapors could be present. Exposure of the electric actuator to corrosive environments may damage the internal components of the device, and will void the warranty.



Dimensions

Figure 1

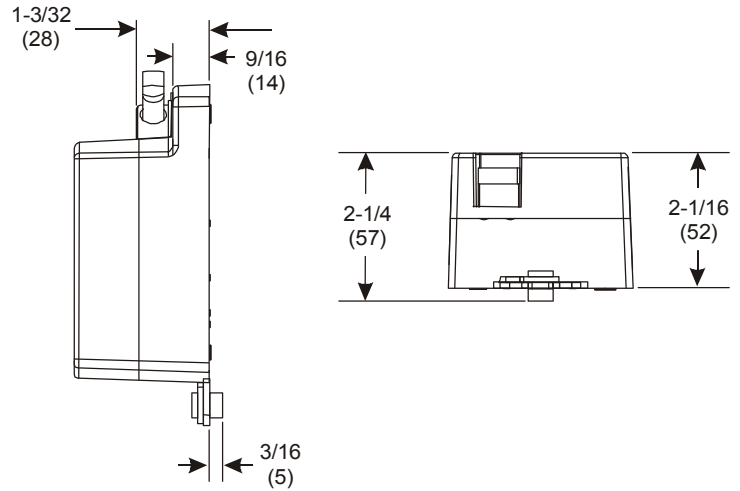
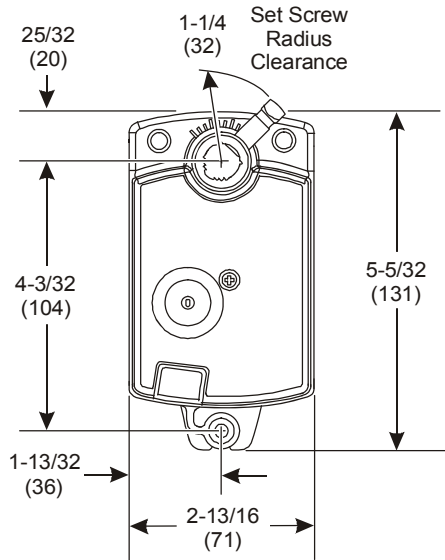

Mounting

To mount the actuator to a damper:

1. Check that the damper blade is visible, or its position is permanently marked on the end of the damper shaft, as illustrated in Figure 2.

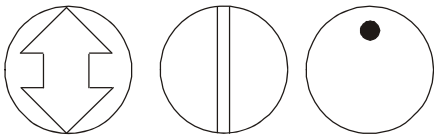

Figure 2: Damper Position Icons

2. Grasp the damper shaft firmly with pliers and rotate the damper fully closed, as illustrated in Figure 3.

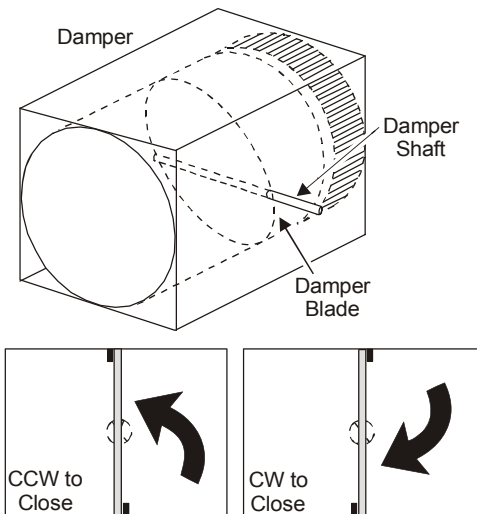

Figure 3: Damper Rotation

3. Make a note of the rotation range and direction, either Clockwise (CW) or Counterclockwise (CCW), required to close the damper.

4. Press and hold the gear release lever, and rotate the actuator coupler to the fully closed position, as determined in Step 2.

5. Position the actuator onto the damper shaft so that the damper shaft protrudes through the actuator coupler, as illustrated in Figure 4.

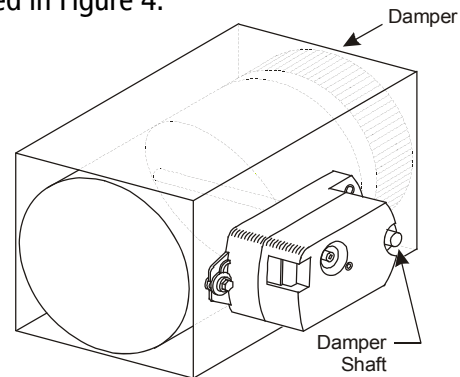

Figure 4: Mounting the Actuator onto the Damper Shaft

6. Be certain that the actuator is in the desired mounting position parallel to the mounting surface, as illustrated in Figure 5.

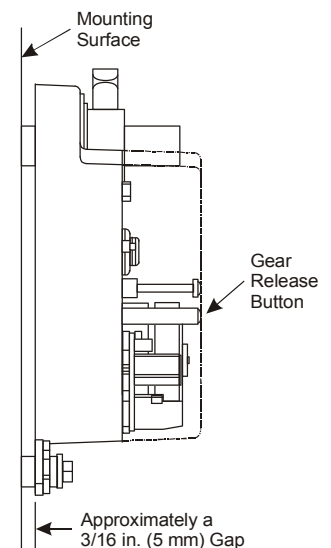
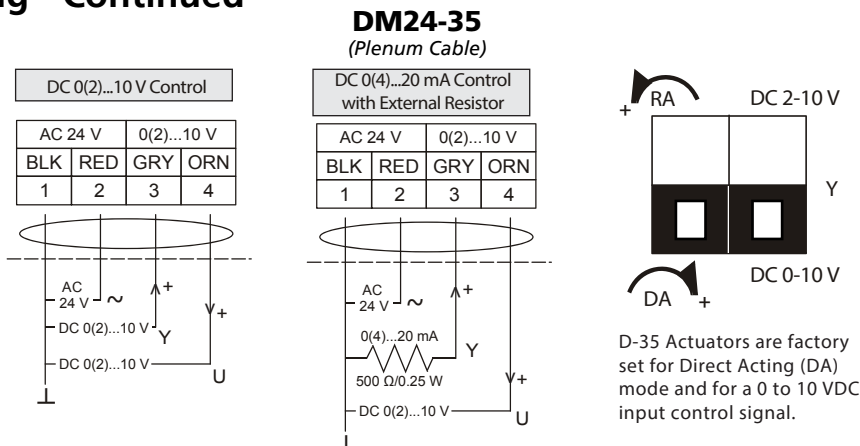

Figure 5: Positioning the Actuator



Wiring - Continued



The DM24-35 Series actuators are factory set for Direct Acting (DA) mode and for a DC 0 to 10 V input control signal. In DA mode, a minimum control signal drives the actuator to the full Counterclockwise (CCW) position, and a maximum control signal drives the actuator to the full Clockwise (CW) position.

D-35 Actuators are factory set for Direct Acting (DA) mode and for a 0 to 10 VDC input control signal.

For Reverse Acting (RA) operation, a minimum control signal drives the actuator to the full CW position and a maximum signal drives the actuator to the full CCW position.

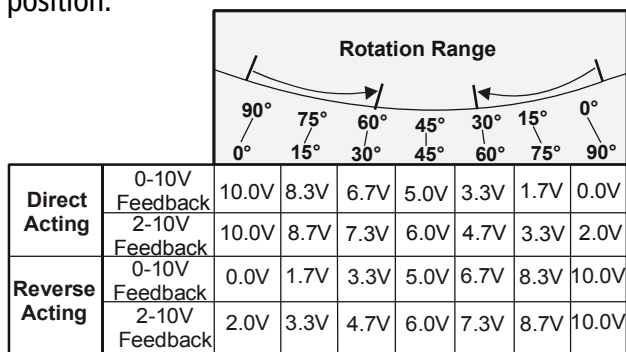

Figure 12: Feedback Signal Relative to the Rotation Range

CAUTION: Risk of Electric Shock. Disconnect power supply before making electrical connections to avoid electric shock.

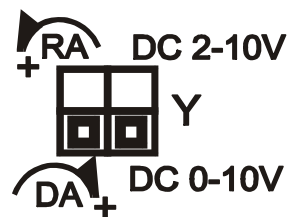

Figure 13: DM24-35 Factory Switch Setting

To change the factory settings (DA, 0-10 V), remove the actuator cover and adjust the switches on the circuit board as shown in Figure 13.

CAUTION: Risk of Property Damage. Do not apply power to the system before checking all wiring connections. Short circuited or improperly connected wires may result in permanent damage to the equipment.

IMPORTANT: Make all wiring connections in accordance with local, national, and regional regulations. Do not exceed the electrical ratings of the D(M)24-35 Series Electric Non-Spring Return Valve Actuator.

Setup and Adjustments

Commissioning

After wiring is completed, apply power to the VAV or VVT controller and provide input signals to the actuator to drive it at least one complete cycle open and closed.

Troubleshooting

- verify that the actuator assembly is properly secured to the duct
- check that all electrical connections are complete and that power is applied
- verify that the damper fully opens and closes, using the gear release button on the actuator
- check that the actuator stroke is set for the desired application