

SoftTouch 2 Installation Instructions

Applications

The ST2 Series Ball Valves are designed to regulate the flow of hot, chilled water and saturated steam up to 15 PSI. in response to the demand of a controller in Heating, Ventilating, and Air Conditioning (HVAC) systems.

IMPORTANT: Use the ST2 Series Valves as an operating control. Where failure or malfunction of the ST2 Series Valve could lead to personal injury or property damage to the controlled equipment or other property, additional precautions must be designed into the system. Incorporate and maintain other devices, such as supervisory or alarm systems or safety or limit controls, intended to warn of or protect against failure or malfunction of the ST2 Series Valve.

IMPORTANT: Take care to prevent foreign material such as weld slag, thread burrs, metal chips, and scale from entering the piping system. This debris can damage or severely impede the operation of the valve by embedding itself in the seats, scoring the valve, and ultimately resulting in seat leakage. If the debris becomes embedded in the seats, subsequent flushing and filtering of the piping system with the valve installed does not remedy the problem.

Installation

Install ST2 Series Ball Valves with the actuator at or above the centerline of the horizontal piping, as shown in Figure 1.

IMPORTANT: In steam applications, install the valve with the stem horizontal to the piping. Failure to follow these guidelines may shorten the life of the actuator.

To minimize heat transfer in steam applications, wrap the valve and piping with insulation. Allow sufficient clearance to remove the actuator (as illustrated in the dimension drawings, (reference dimensional Information).

When mounting the actuator in the field (before installation), use an adjustable wrench to manually rotate the valve stem several times. This rotation breaks the torque that may have built up during long-term storage.

For the valve to move in the proper direction, wire the input lines to the electric actuator correctly.

Note: On models with the flow-characterizing disk, the disk is located in Port A. Port A must be the inlet. On three-way models, use Port A as the coil inlet and Port B as the bypass inlet.

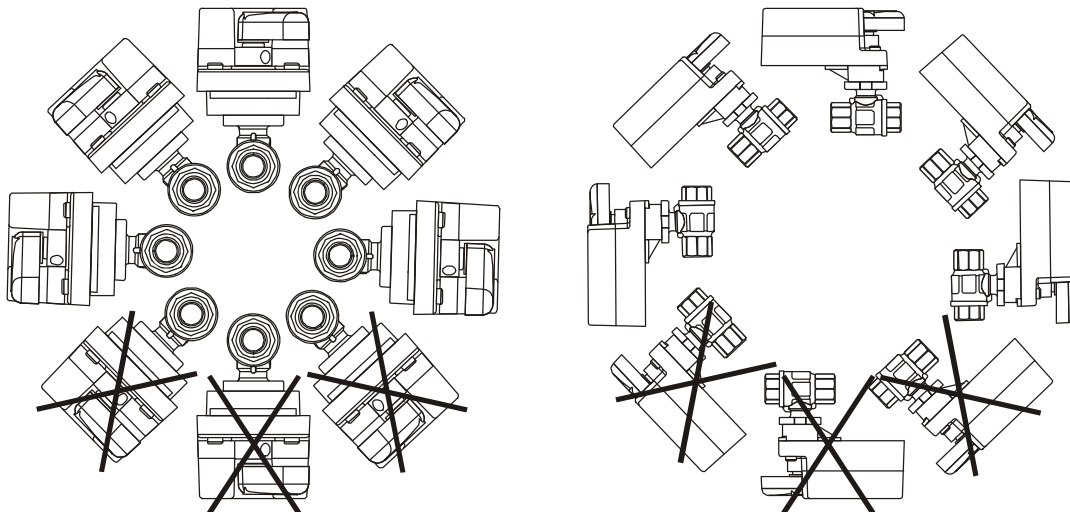
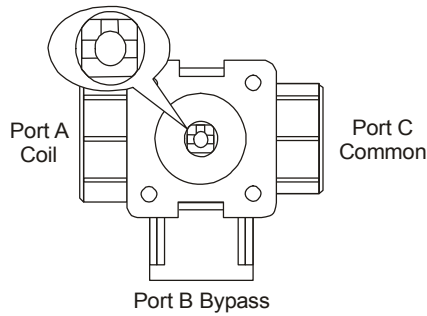
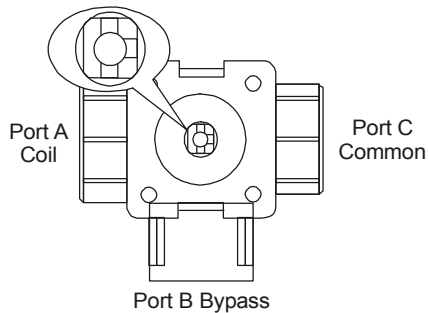

Figure 1: Mounting Positions for Chilled Water and Condensing Atmosphere Applications

Port Configuration



**ST2 Series Three-Way
Ball Valve (Port A Connected to Port C)**



**ST2 Series Three-Way
Ball Valve (Port B Connected to Port C)**

IMPORTANT: Protect the actuator from dripping water, condensation, and other moisture. Water or moisture could result in an electrical short, which may damage or affect the operation of the actuator.

IMPORTANT: Do not cover the actuator with thermal insulating material. High ambient temperatures may damage the actuator, and a hot water pipe, steam pipe, or other heat source may overheat it.

Contact your local Bray representative for compatibility concerns before using ST2 Series Ball Valves to control the flow of fluids other than those outlined in the *Technical Specifications* table in this document.

Press Valve Installation

ST2 press end connection valves are installed using RIDGID® press tools. Always refer to the operator's manual supplied with the RIDGID press tool that is used to make the valve end connections. The manual should provide proper instructions for the safe operation of the tool, proper crimping procedures, and methods of inspecting the finished connection. If you use a battery-operated press tool, ensure its proper operation by fully charging the unit. To avoid damage to the integral O-ring, never use sealant or pipe dope with a press connection. Always inspect the end connections of the valve before making the connection. The end connection should not be deformed, and the internal, integral O-ring must be in place for a proper seal.

Sweat Valve Installation

When soft soldering sweat ball valves, be sure to use a low temperature solder with a melting point that does not exceed 450°F (232°C). For lead-free RoHS compliance, a 96.5% tin/3.5% silver solder is recommended. Never install the actuator on the valve until you have completed the soldering operation and the valve body has cooled. Before soldering, minimize the risk of damage to the ball seals by positioning the ball so that Port A is fully open. When soldering, always apply a wet rag around the valve's neck and cover as much of the valve body with the rag as possible. Direct the tip of the flame away from the valve and always heat the copper tubing directly, but never the valve body. Solder Port A first, then the remaining ports. These steps provide maximum protection to the internal valve components. See Figure 2 for details.

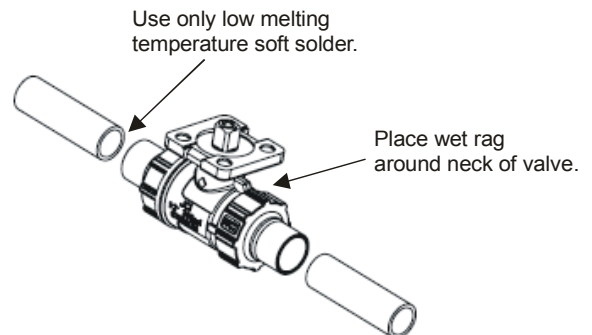

Figure 5: Sweat Valve Installation

Wiring

Be sure to wire the input lines to the electric actuator correctly for the valve to move in the proper direction.

IMPORTANT: Use copper conductors only. Make all wiring connections in accordance with local, national, and regional regulations. Do not exceed the actuator's electrical ratings.



WARNING: Risk of Electric Shock. Disconnect the power supply before making electrical connections. Contact with components carrying hazardous voltage can cause electric shock and may result in severe personal injury or death.

Troubleshooting

Servicing the Actuator or Piping System

When servicing the electric actuator or the piping system:

- disconnect the power supply to the actuator.
- relieve the pressure in the piping system.

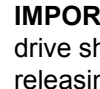

IMPORTANT: Do not attempt to manually rotate the drive shaft while the actuator is installed without first releasing the actuator gears. Manually rotating the drive shaft without releasing the actuator gears may result in permanent damage to the actuator.



CAUTION: Risk of Property Damage. Do not apply power to the system before checking all wiring connections. Short circuited or improperly connected wires may result in permanent damage to the equipment.

Technical Specifications

Service		Hot Water, Chilled Water, 50/50 Glycol Solutions 15 psig (103 kPa) Saturated Steam for HVAC Systems
Valve Body Pressure/ Temperature Rating	Cold Working Pressure (CWP)	580 PSI (PN 40)
	Water (with Standard Mounting)	-22°F to 203°F (-30°C to 95°C)
	Water (with "High Temp" Mounting)	-22°F to 284°F (-30°C to 140°C)
	Steam (with "High Temp" Mounting)	15 PSIG (103 kPa) at 284°F (140°C)
Maximum Recommended Operating Pressure Drop		50 psi Maximum Differential Pressure for Valves with Characterized Flow Control Disk and 30 psi Maximum for Quiet Service Ball Valves
Flow Characteristics	Two-Way	Equal Percentage
	Three-Way	Equal Percentage Port A, Linear Port B (Bypass)
Rangeability		Greater than 500:1
Minimum Ambient Operating		See Actuator Specifications
Leakage		.01% of Maximum Flow per ANSI/FCI 70-2, Class 4 1% of Maximum Flow for Three-Way Bypass Port
End Connections		NPT or BSP
Materials	Body	Forged Brass
	Ball	300 Series Stainless Steel
	Stem	300 Series Stainless Steel
	Seats	Graphite-Reinforced PTFE with EPDM O-ring backing
	Stem Seals	EPDM Double O-rings
	Characterizing Disk	Amodel®
Close-Off		200 PSI
Compliance CRN		OC16910.5

Disclaimer - The performance specifications are nominal and conform to acceptable industry standards. For application at conditions beyond these specifications, consult the local Bray office. Bray, Inc. shall not be liable for damages resulting from misapplication or misuse of its products.

ST2 Series Piping and Installation Tips

2-Way Piping Schematics

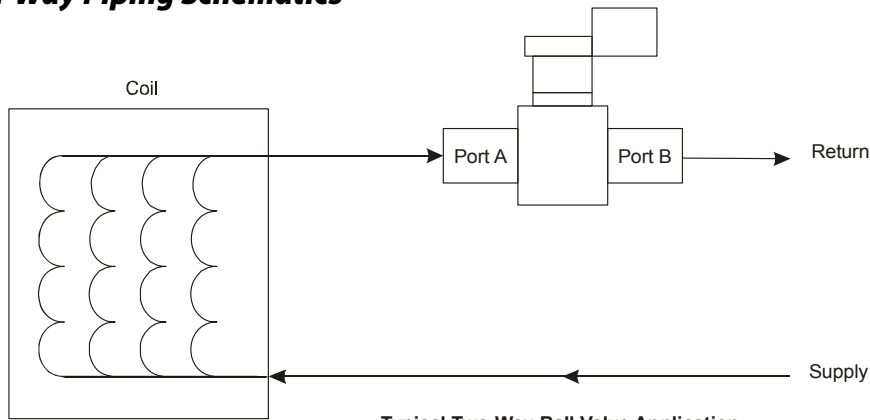

Typical Two-Way Ball Valve Application

Note: Mount the valve downstream from the coil to minimize heat transfer to the actuator.

2-Way - Default Configuration for ST2 Ball Valves

Valve Position at Actuator Position	2-Way Non Spring Return	2-Way Spring Return N.O	2-Way Spring Return N.C.
Valve Position w/ Act CCW	Open	Open	Open
Valve position w/Act CW	Closed	Closed	Closed
Valve Position w power removed	Last Position	Open	Closed
Proportional actuator control signal Action (Direct Acting)*	CCW at 0; CW at Max	CCW at 0, CW at Max	CW at 0, CCW at Max

*Proportional actuators include a switch to field convert from Direct Acting to Reverse Action

3-Way Piping Schematics

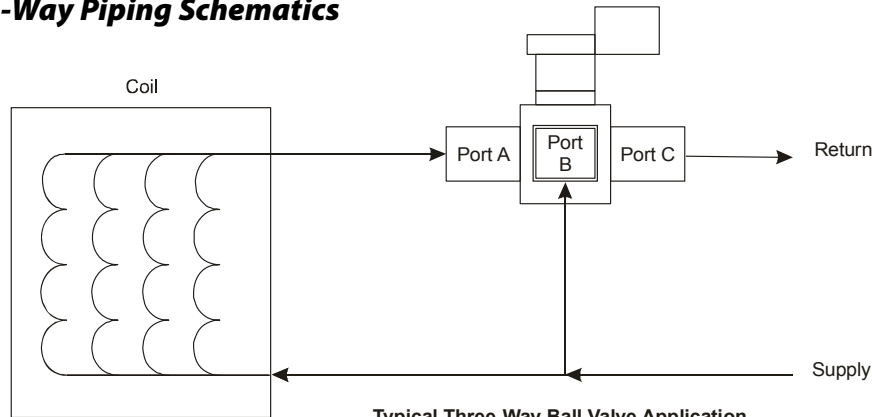

Typical Three-Way Ball Valve Application

Note: Mount the valve downstream from the coil to minimize heat transfer to the actuator. For pure diverting applications (one inlet/two outlets), only the standard port (no characterization disc) versions will work.

3-Way - Default Configuration for ST2 Ball Valves

Valve Position at Actuator Position	3-Way Non Spring Return	3-Way Spring Return N.O	3-Way Spring Return N.C.
Valve Position w/ Act CCW	A open to C	A open to C	A open to C
Valve position w/Act CW	B open to C	B open to C	B open to C
Valve Position w power removed	Last Position	A open to C	B open to C
Proportional actuator control signal Action (Direct Acting)*	CCW at 0; CW at Max	CCW at 0, CW at Max	CW at 0, CCW at Max

*Proportional actuators include a switch to field convert from Direct Acting to Reverse Action

SoftTouch 2 - 2-Way Dimensions

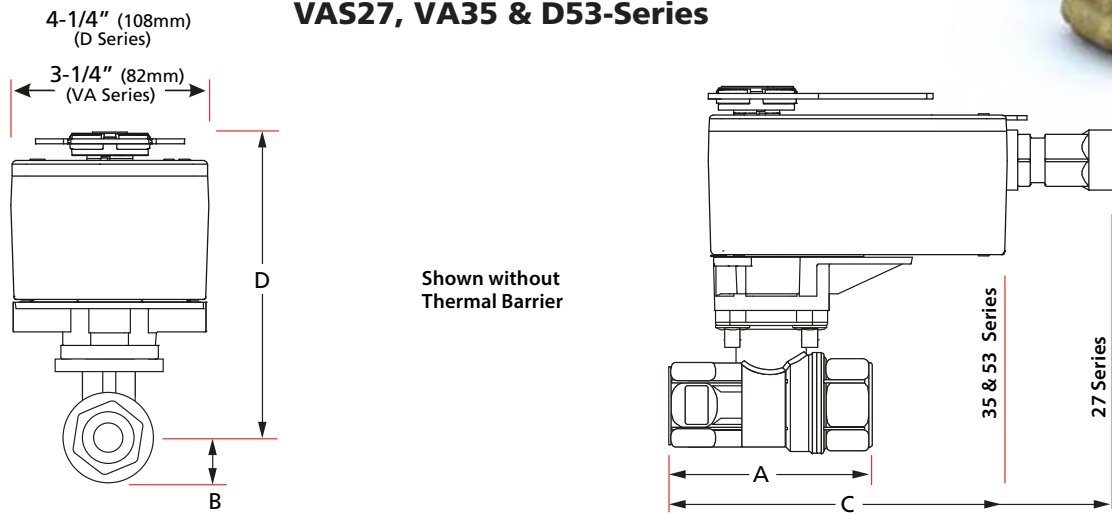

ST2 Dimensions - 2-Way - VAS 27 Series

Direct Mount	ST2 VALVE MODEL # PREFIX ST2 Size-Way-Cv	Connection		Available Cv's	Please reference the illustration									
					A		B		C		D*		Weight	
					in.	mm	in.	mm	in.	mm	in.	mm	lb	kg
	ST2-05-2-...	1/2	15	0.46, 0.73, 1.2, 1.9, 2.9, 4.7, 11.7	2-1/2	64	5/8	17	6-31/32	177	4-5/8	117.3	3.0	1.4
	ST2-75-2-...	3/4	20	4.7, 7.4, 11.7	2-13/16	71	5/8	17	7-1/8	181	4-5/8	117.3	3.1	1.4
	ST2-1-2-...	1	25	7.4, 11.7, 18.7	3-7/16	87	3/4	19	7-31/64	190	4-11/16	119.0	3.4	1.5
	ST2-125-2-...	1-1/4	32	11.7, 18.7, 29.2	3-15/16	101	1	26	7-3/4	197	5-9/64	130.3	5.7	2.6
	ST2-150-2-...	1-1/2	40	18.7, 29.2, 46.8	4-5/16	109	1-1/8	29	7-21/23	201	5-19/64	134.3	6.4	2.9
	ST2-2-2-...	2	50	29.2, 46.8, 73.7	4-7/8	124	1-1/2	37	8-1/4	209	5-17/32	140.3	8.1	3.7

ST2 Dimensions - 2-Way - VA 35 Series

Direct Mount	ST2 VALVE MODEL # PREFIX ST2 Size-Way-Cv	Connection		Available Cv's	Please reference the illustration									
					A		B		C		D*		Weight	
					in.	mm	in.	mm	in.	mm	in.	mm	lb	kg
	ST2-05-2-...	1/2	15	0.46, 0.73, 1.2, 1.9, 2.9, 4.7, 11.7	2-1/2	64	5/8	17	5-7/64	129	3-7/8	98	3.0	1.4
	ST2-75-2-...	3/4	20	4.7, 7.4, 11.7	2-13/16	71	5/8	17	5-7/32	133	3-7/8	98	3.1	1.4
	ST2-1-2-...	1	25	7.4, 11.7, 18.7	3-7/16	87	3/4	19	5-9/16	141	3-11/16	100	3.4	1.5
	ST2-125-2-...	1-1/4	32	11.7, 18.7, 29.2	3-15/16	101	1	26	5-13/16	148	4-3/8	111	5.7	2.6
	ST2-150-2-...	1-1/2	40	18.7, 29.2, 46.8	4-5/16	109	1-1/8	29	6-1/2	152	4-9/17	115	6.4	2.9
	ST2-2-2-...	2	50	29.2, 46.8, 73.7	4-7/8	124	1-1/2	37	6-1/3	160	4-3/4	121	8.1	3.7

ST2 Dimensions - 2-Way - D 53 Series

Universal Mount	ST2 VALVE MODEL # PREFIX ST2 Size-Way-Cv	Connection		Available Cv's	Please reference the illustration									
					A		B		C		D*		Weight	
					in.	mm	in.	mm	in.	mm	in.	mm	lb	kg
	ST2-125-2-...	1-1/4	32	11.7, 18.7, 29.2	3-15/16	100	1	26	7-7/8	175	6-7/16	164	5.7	2.6
	ST2-150-2-...	1-1/2	40	18.7, 29.2, 46.8	4-5/16	110	1-1/8	29	8-1/16	180	6-5/8	168	6.4	2.9
	ST2-2-2-...	2	50	29.2, 46.8, 73.7	4-13/16	123	1-1/2	38	8-5/16	186	6-3/4	171	8.1	3.7

Dimensions may vary, depending on the actuator.
Weights shown are for valve bodies only.
Allow 3-1/2" clearance for actuator removal.

Dimensions are shown in inches and are approximate.
* Add 1-3/4" additional height for High Temp mounting kit. (-HT)

SoftTouch 2 - 3-Way Dimensions



Universal Mount D-Series

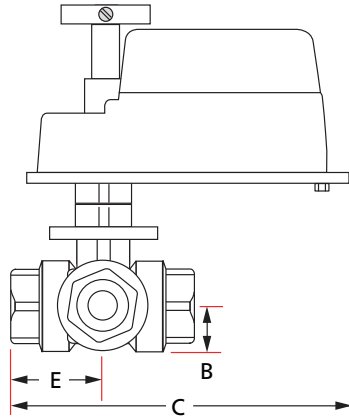

Direct Mount VA-Series

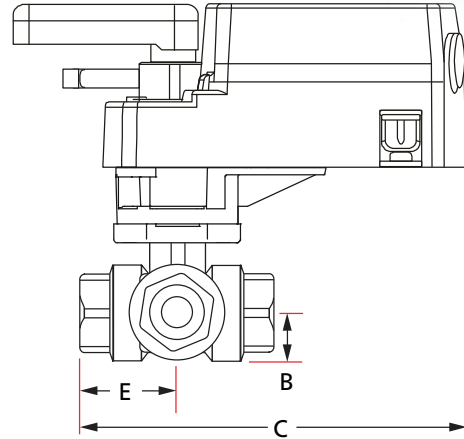

Shown without Thermal Barrier

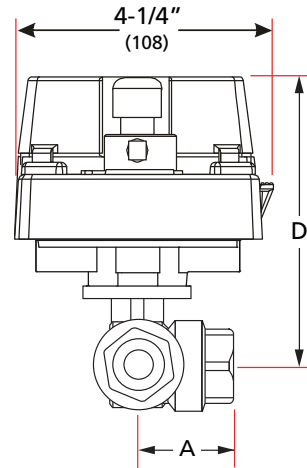
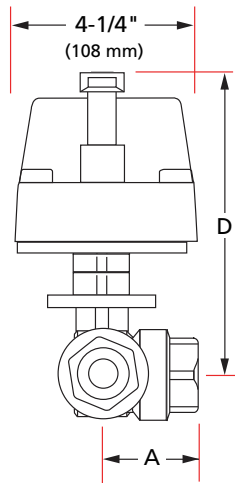

ST2 Dimensions - 3-Way

	ST2 VALVE MODEL # PREFIX ST2 Size-Way-Cv	Connection		Available Cv's	Please reference the illustration											
		in.	mm		A		B		C		D*		E		Weight	
					in.	mm	in.	mm	in.	mm	in.	mm	in.	mm	lb	kg
Direct Mount	ST2-05-3-...	1/2	15	1.2, 1.9, 2.9, 4.7, 11.7	1-1/4	32	5/8	16	6-3/4	172	4-5/8	118	1-1/4	32	3.0	1.4
	ST2-75-3-...	3/4	20	4.7, 7.4, 11.7	1-13/32	36	5/8	16	6-15/16	176	4-5/8	118	1-3/8	36	3.2	1.5
	ST2-1-3-...	1	25	7.4, 11.7, 18.7	1-11/16	43	3/4	19	7-3/16	183	4-11/16	119	1-11/16	43	3.3	1.5
	ST2-125-3-...	1-1/4	32	11.7, 18.7, 29.2	1-15/16	49	1	26	7-1/2	191	5-1/8	130	1-15/16	50	6.1	2.8
	ST2-150-3-...	1-1/2	40	18.7, 29.2, 46.8	2-1/4	57	1-1/8	29	7-13/16	198	5-3/16	148	2-3/16	55	6.9	3.1
	ST2-2-3-...	2	50	29.2, 46.8, 73.7	2-5/8	67	1-3/8	35	8-3/8	213	5-3/8	137	2-7/16	62	9.5	4.3
Universal Mount	ST2-125-3-...	1-1/4	32	11.7, 18.7, 29.2	2	51	1	26	7-7/8	175	6-7/16	164	1-15/16	50	5.0	2.3
	ST2-150-3-...	1-1/2	40	18.7, 29.2, 46.8	2-1/8	54	1-1/8	29	8-1/16	180	6-5/8	168	2-3/16	55	5.8	2.6
	ST2-2-3-...	2	50	29.2, 46.8, 73.7	2-9/16	65	1-1/2	38	8-5/16	186	6-3/4	171	2-7/16	62	7.7	3.5

Dimensions may vary, depending on the actuator.
Weights shown are for valve bodies only.
Allow 3-1/2" clearance for actuator removal.

Dimensions are shown in inches and are approximate.
* Add 1-3/4" additional height for High Temp mounting kit. (-HT)
Dimensions are shown for the largest spring return actuator currently available.