

The BV Series Threaded Industrial Ball Valve product line is ideally suited to high temperature and high pressure water or steam as well as a wide range of heavy commercial HVAC control applications. These valves provide exceptional characterized control, high rangeability, flow capacity and pressure drops; all with bi-directional bubble tight shut off. Valves in this range feature investment cast 3 piece construction, Carbon Steel housings and Stainless Steel balls and stems with NPT threaded connections. Characterized V-Balls and full port versions provide multiple Cv values in each size.



Features and Benefits

- **High Cycle Packing Design**
Years of trouble free service
- **Bubble Tight Shut-Off with Zero Leakage**
Energy efficient
- **3-Piece Body Design**
Allows in-line servicing
- **Phosphate Coated Carbon Steel Bodies**
For cost effective applications up to 1,000 psi at 225°F
- **Available Commercial Grade & NEMA 4 Actuators**
Reliable, cost effective control

Increased Linear Response

Due to the in-line design inherent with characterized control ball valves, line media flows linearly through the piping system. The direct pattern provides increased media control and rapid response times to controller commands.

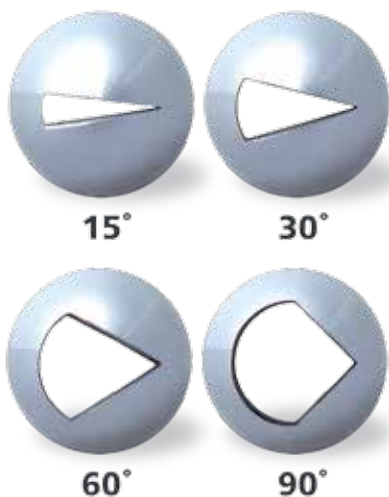

Flow Curve Chart

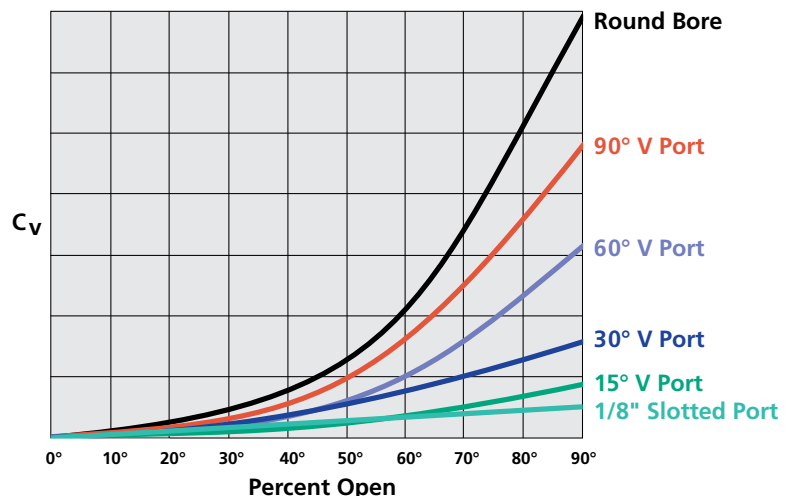

These curves of standard ports are general guidelines and are not specific to any particular valve size.

BV - Specifications

Technical Specifications - BV Threaded Industrial Ball Valve , 1/2" - 4" - 2-Way

Carbon Steel Body		V-Port	Full-Port
Service		Chilled/Hot Water, 50/50 Glycol Solutions and Saturated Steam	
Size		1/2" to 4" Threaded Valves, 2-Way	
Maximum Fluid Temperature	Water	-20° to 225°F at 1000 PSI (-28° to 107°C at 6,895 kPa)	
	Steam	100 PSI (689 kPa)	
Valve Body Pressure Rating		1000 PSI (6895 kPa)	
Maximum Close-Off Pressure		300 PSI (2,068 kPa)* For higher close-offs contact Bray.	
Maximum Recommended Pressure Drop	Water	80 PSI (551 kPa)	
	Steam	50 PSI (344 kPa)	
Flow Characteristic	V15 Port	Linear	NA
	V30 Port	Modified Equal Percentage	NA
	V60 & 90 Port	Equal Percentage	NA
Rangeability		200:1	
Leakage		Bubble Tight per API 598	
End Connections		Threaded NPT	
Ambient Operating Temperature Range		See Actuator Rating (Optional high temperature mounting kit may be required)	
Materials	Body	WCB Carbon Steel	
	Ball & Stem	316 Stainless Steel	
	Seat	Tek-Fil	RPTFE
	Stem Seal/Packing	RPTFE	
	Body Seal	TFM	
	Body Bolts	SS304	

Disclaimer - The performance specifications are nominal and conform to acceptable industry standards. For application at conditions beyond these specifications, consult the local Bray office. Bray, Inc. shall not be liable for damages resulting from misapplication or misuse of its products.

BV - Piping Diagram

- "V-Port valves- Note the arrow engraved on the ends which shows the flow going from the bolt head to the nut so that the V-ball is downstream.
- "Full Port valves are bi-directional.

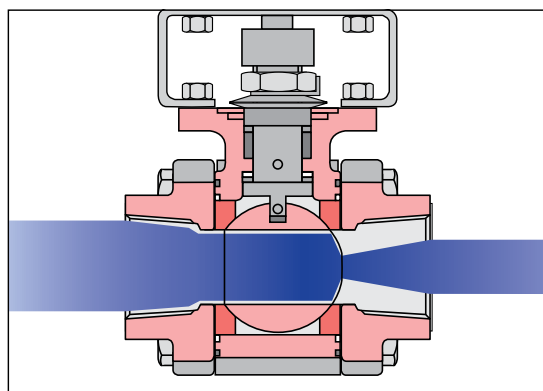

Media Flow entering valve from left. Installing the V downstream is preferred.

BV - For Steam Applications

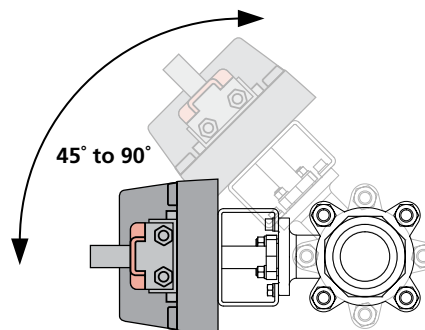

Install valve with stem at 45° to 90° from vertical.

BV - Flow Coefficient Cv Chart

BV-Segmented Ball Valve - Tek Fil Seat - Class 150											
Size	V-Port Angle	Percent of Ball Rotation									
		10%	20%	30%	40%	50%	60%	70%	80%	90%	100%
1/2"	15°	0.04	0.17	0.43	0.68	0.98	1.62	2.09	2.84	3.61	4.18
1/2"	30°	0.04	0.23	0.47	0.77	1.19	1.83	2.47	3.43	4.65	5.55
1/2"	60°	0.04	0.28	0.73	1.11	1.83	2.92	4.29	7.00	9.43	12.78
1/2"	90°	0.06	0.47	0.85	1.28	2.05	3.24	4.74	8.26	11.61	14.72
1/2"*	90°	0.00	0.00	0.70	3.70	7.80	12.60	17.90	23.30	28.60	32.00
3/4"	15°	0.05	0.20	0.51	0.88	1.30	2.13	2.75	3.74	4.75	5.51
3/4"	30°	0.07	0.30	0.61	0.99	1.57	2.42	3.25	4.52	6.12	7.30
3/4"	60°	0.07	0.35	0.93	1.46	2.42	3.85	5.64	9.21	12.41	16.25
3/4"	90°	0.08	0.59	1.11	1.69	2.69	4.27	6.24	10.85	15.28	19.37
3/4"*	90°	0.00	0.00	2.50	7.70	14.20	21.70	29.70	38.00	46.20	54.00
1"	15°	0.06	0.30	0.93	1.49	2.31	3.75	4.67	6.47	8.46	9.84
1"	30°	0.08	0.45	1.25	2.06	3.54	5.30	7.70	10.49	12.84	15.48
1"	60°	0.09	0.68	1.74	2.78	5.13	8.00	11.88	18.71	23.22	32.81
1"	90°	0.11	0.93	2.78	5.09	7.74	12.20	17.33	22.50	31.40	43.89
1"*	90°	0.00	1.20	8.60	19.40	32.40	46.70	61.90	77.30	92.40	105.00
1-1/4"	15°	0.03	0.27	0.83	1.64	2.78	4.07	5.88	7.99	10.81	12.82
1-1/4"	30°	0.05	0.48	1.37	2.47	4.12	6.08	8.82	11.76	17.87	17.37
1-1/4"	60°	0.07	0.67	2.04	3.41	6.47	10.80	15.39	22.35	33.37	43.45
1-1/4"	90°	0.08	0.78	2.92	5.41	10.23	17.28	25.50	35.60	51.76	65.81
1-1/4"*	90°	0.00	5.30	20.70	41.30	65.40	91.70	119.30	147.20	174.50	200.00
1-1/2"	15°	0.05	0.37	1.15	2.26	3.82	5.59	8.08	10.99	14.86	17.62
1-1/2"	30°	0.07	0.65	1.88	3.39	5.66	8.36	12.12	16.17	20.44	23.88
1-1/2"	60°	0.09	0.92	2.81	4.69	8.89	14.85	21.16	30.73	45.88	59.74
1-1/2"	90°	0.10	1.07	4.01	7.44	14.06	22.60	31.90	48.03	71.17	90.49
1-1/2"*	90°	0.00	3.40	22.70	50.70	83.90	120.80	159.70	199.40	238.40	275.00
2"	15°	0.06	0.69	2.23	4.45	7.24	10.68	15.38	21.39	28.75	34.69
2"	30°	0.09	1.18	3.79	7.53	12.26	17.83	26.44	36.45	48.09	55.85
2"	60°	0.11	1.51	5.80	10.39	20.60	33.98	48.75	69.04	104.23	135.75
2"	90°	0.16	1.89	7.28	13.58	25.38	42.30	55.56	87.04	129.75	167.34
2"*	90°	0.00	15.50	54.80	106.60	166.60	232.00	300.40	369.50	437.00	500.00
2-1/2"	15°	0.07	0.77	2.40	5.23	8.06	11.73	16.42	22.31	27.24	31.30
2-1/2"	30°	0.09	1.15	4.42	7.91	13.39	20.05	30.43	41.92	56.30	76.95
2-1/2"	60°	0.13	1.46	5.91	11.90	23.24	37.92	59.31	83.29	113.65	162.50
2-1/2"	90°	0.17	1.83	7.29	16.45	31.16	53.53	77.89	118.29	177.32	239.45
2-1/2"*	90°	0.00	25.80	87.60	168.60	262.10	363.90	470.20	577.50	682.30	780.00
3"	15°	0.08	0.89	2.96	6.65	9.58	13.42	19.47	26.67	31.79	38.31
3"	30°	0.12	1.20	4.15	9.49	15.96	26.78	38.91	53.31	69.77	85.91
3"	60°	0.15	2.89	6.70	15.82	29.36	46.32	73.60	106.74	149.88	193.20
3"	90°	0.20	4.12	8.65	21.09	41.09	69.27	105.91	161.04	237.23	359.21
3"*	90°	0.00	33.80	123.70	242.70	380.80	531.50	689.30	848.70	1004.50	1150.00
4"	15°	0.11	1.40	3.73	8.86	16.76	27.91	41.85	59.24	75.49	96.37
4"	30°	0.16	1.75	7.84	18.59	35.21	58.60	87.89	124.41	158.53	196.35
4"	60°	0.26	2.20	12.44	33.67	62.98	106.26	160.49	233.96	329.50	437.29
4"	90°	0.35	4.37	19.68	50.29	91.83	157.43	240.51	365.15	546.62	830.86
4"*	90°	7.50	118.90	296.20	516.20	766.50	1035.80	1314.30	1592.70	1861.80	2100.00

* Full Port Valves

BV - Mode of Actuation

Typical Two-Way Ball Valve Application

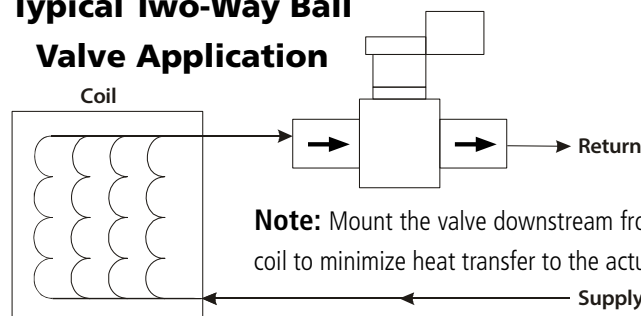

BV - Cut Away View

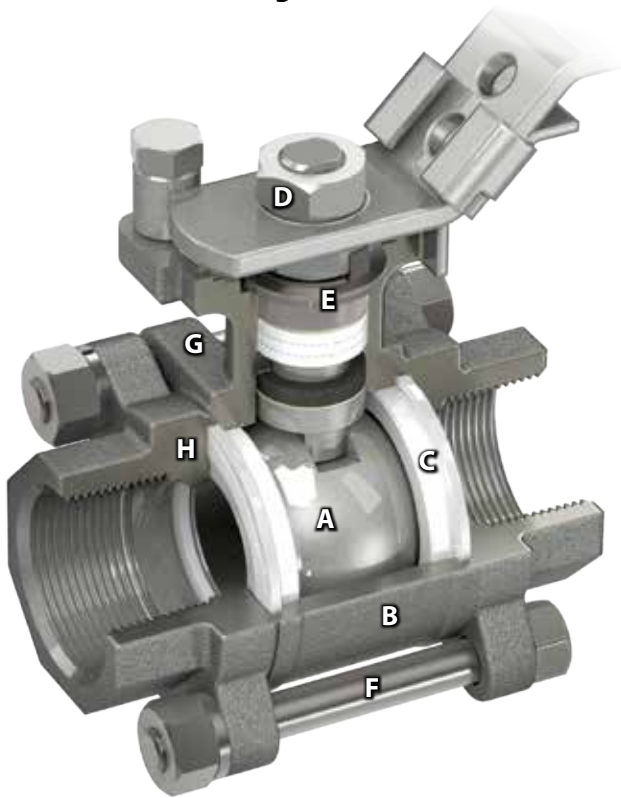

Ball (A) Is a precision machined and mirror finished for bubble-tight shut off with less operating torque. Ball edges have machined curvatures to reduce seat wear and provide a high cycle life.

Body (B) Valve bodies are investment cast and solution annealed/normalized for the highest quality and added strength. Body castings are marked with a foundry heat number for full traceability. Carbon steel bodies are phosphate coated for increased corrosion resistance.

Seat (C) The seat design ensures bi-directional, bubble-tight sealing while providing the lowest possible torque. This seat design reduces friction, minimizes seat wear and reduces operating torque.

Double Lock Nut Design (D) These double lock nuts allow handles to be easily and safely removed while the valve is under full line pressure.

Live-Loaded Stem Seals (E) The live-loaded seals considerably increase the number of cycles between maintenance adjustments.

Body Bolts (F) Standard material is 304 Stainless Steel.

Body Hinges (G) Heavy duty hinges, throughout the entire size range, provide positive alignment of body to end connection during swing-out, in-line servicing.

End Connections (H) Full range of interchangeable connections. Anti-Static Protection BV Series valves feature anti-static grounding devices as standard. These devices ensure electrical continuity between valve ball, stem and body, thus eliminating the possibility of static electrical charges creating sparks within the valve.

Smart Stem

Valve Sizes 1/2" through 2-1/2"

These Interchangeable series of valves feature strong, large diameter stems with live-loaded, self-adjusting sealing utilizing belleville washers which automatically adjust to compensate for changes in temperature and wear. Manual adjustments which can cause damage to the seal and seat are not required. The assembly is secured by a saddle-type lock washer which prevents stem nuts from un-threading in high cycle automation applications.

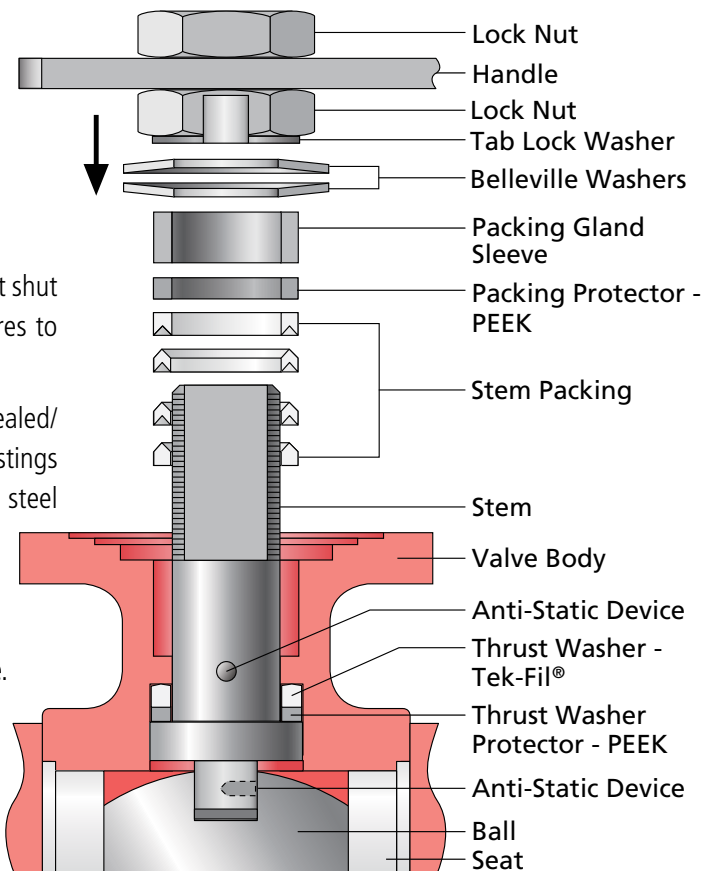

Stem Packing

An adjustable V-ring design creates a multiple seal between the stem and body. Each stem assembly is composed of three or four (dependent on valve size) rings providing a very high cycle life by resisting creep and cold flow. The Thrust Washer and the Thrust Washer Protector combine to provide a primary seal, reduce torque and prevent galling. This arrangement is a BV Series exclusive.

BV -2-Way-Threaded Ball Valve/Commercial Actuator Dimensions

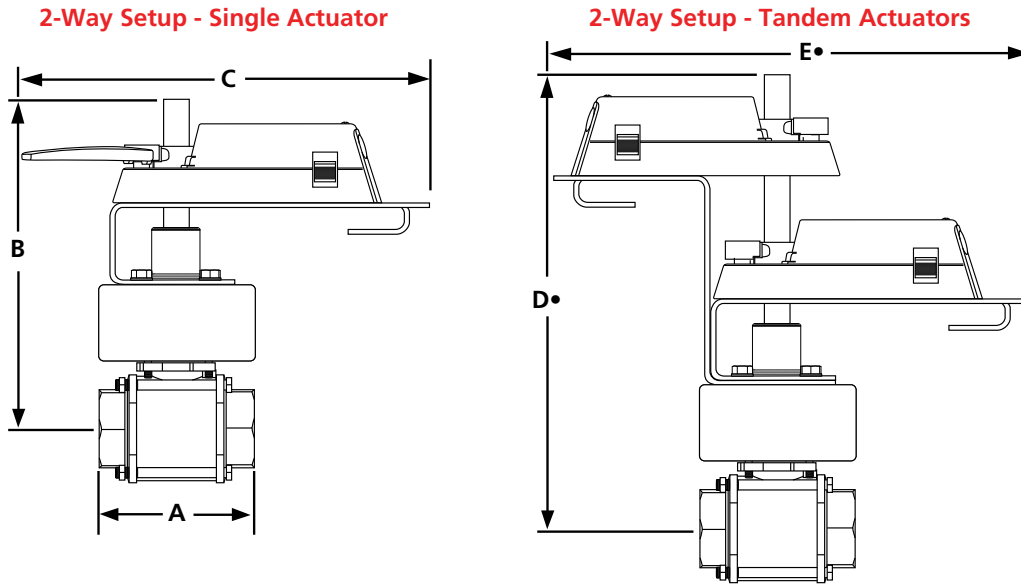

2-Way BV Dimensions, 1/2" - 1-1/2" - Threaded BV Series - with Commercial Actuators

Valve Models	Size		Flow Coefficient		A	B	C	Tandem Actuators		Weight ¹	
	in.	mm	Cv	Kv				D•	E•	lbs.	kg.
BV05-CS3-04	1/2	15	4.2	3.6	2.8 (71)	9.7 (246)	14.5 (368)			1.8	.82
BV05-CS3-05			5.6	4.8							
BV05-CS3-09			12.8	11.1							
BV05-CS3-12			14.7	12.7							
BV05-CS3-32			32.0*	27.7							
BV75-CS3-05	3/4	20	5.5	4.8	3.4 (86)	9.8 (249)	14.5 (368)			2.3	1.04
BV75-CS3-06			7.3	6.3							
BV75-CS3-12			16.3	10.7							
BV75-CS3-15			19.3	16.7							
BV75-CS3-54			54.0*	46.7							
BV1-CS3-09	1	25	9.8	8.5	3.6 (91)	10.2 (259)	14.5 (368)			3.4	1.5
BV1-CS3-13			15.5	13.4							
BV1-CS3-23			32.8	28.4							
BV1-CS3-31			43.9	38.0							
BV1-CS3-105			105.0*	90.8							
BV125-CS3-11	1.25	32	12.8	11.1	4.3 (109)	10.4 (264)	14.5 (368)	17.5 (445)	18.0 (457)	4.9	2.2
BV125-CS3-15			17.4	15.0							
BV125-CS3-33			43.5	37.6							
BV125-CS3-52			65.8	56.9							
BV125-CS3-200			200.0*	173.0							
BV150-CS3-15	1.50	40	17.6	15.2	4.8 (122)			17.9 (455)	18.0 (457)	7.6	3.4
BV150-CS3-20			23.9	20.7							
BV150-CS3-46			59.7	51.6							
BV150-CS3-71			90.5	78.3							
BV150-CS3-275			275.0*	237.8							

¹ - Weights are for valve bodies only.
 • Indicates tandem mounted actuators are required.
 - Largest Actuator dimension shown.
 * Full Port Valves
 For steam applications, install valve with stem at 45° to 90° from vertical.

BV -2-Way - Threaded Ball Valve/Industrial Actuator Dimensions

2-Way Setup - Industrial Actuator

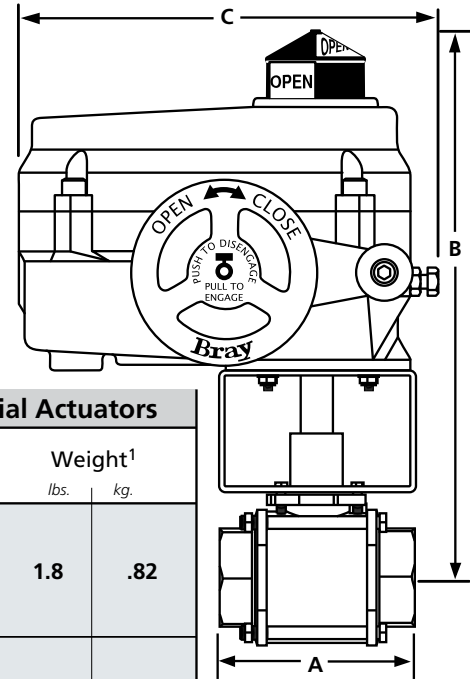

2-Way BV Dimensions, 1/2" - 4" - Threaded BV Series - with Industrial Actuators

Valve Models	Size		Flow Coefficient		A	B	C	Weight ¹	
	in.	mm	Cv	Kv				lbs.	kg.
BV05-CS3-04	1/2	15	4.2	3.6	2.8 (71)	9.8 (249)	7.5 (191)	1.8	.82
BV05-CS3-05			5.6	4.8					
BV05-CS3-09			12.8	11.1					
BV05-CS3-12			14.7	12.7					
BV05-CS3-32			32.0*	27.7					
BV75-CS3-05	3/4	20	5.5	4.8	3.4 (86)	9.9 (252)	7.5 (191)	2.3	1.04
BV75-CS3-06			7.3	6.3					
BV75-CS3-12			16.3	10.7					
BV75-CS3-15			19.3	16.7					
BV75-CS3-54			54.0*	46.7					
BV1-CS3-09	1	25	9.8	8.5	3.6 (91)	10.3 (262)	7.5 (191)	3.4	1.5
BV1-CS3-13			15.5	13.4					
BV1-CS3-23			32.8	28.4					
BV1-CS3-31			43.9	38.0					
BV1-CS3-105			105.0*	90.8					
BV125-CS3-11	1.25	32	12.8	11.1	4.3 (109)	10.5 (267)	7.5 (191)	4.9	2.2
BV125-CS3-15			17.4	15.0					
BV125-CS3-33			43.5	37.6					
BV125-CS3-52			65.8	56.9					
BV125-CS3-200			200.0*	173.0					
BV150-CS3-15	1.50	40	17.6	15.2	4.8 (122)	11.2 (285)	7.5 (191)	7.6	3.4
BV150-CS3-20			23.9	20.7					
BV150-CS3-46			59.7	51.6					
BV150-CS3-71			90.5	78.3					
BV150-CS3-275			275.0*	237.8					
BV2-CS3-29	2	50	34.7	30.0	5.6 (142)	11.5 (292)	7.5 (191)	11.4	5.2
BV2-CS3-48			55.9	48.3					
BV2-CS3-104			135.8	117.5					
BV2-CS3-130			167.3	144.7					
BV2-CS3-500			500.0*	432.4					
BV250-CS3-27	2.50	65	31.3	27.1	7.3 (231)	13.4 (340)	10.1 (257)	21.8	9.9
BV250-CS3-56			77.0	66.6					
BV250-CS3-114			162.5	140.5					
BV250-CS3-177			239.5	207.1					
BV250-CS3-780			780.0*	674.6					
BV3-CS3-32	3	80	38.3	33.1	8.0 (257)	15.8 (401)	10.1 (257)	34.6	15.7
BV3-CS3-70			85.9	74.3					
BV3-CS3-150			193.2	167.1					
BV3-CS3-237			359.2	310.7					
BV3-CS3-1150			1,150.0*	994.6					
BV4-CS3-76	4	100	96.4	83.4	9.1 (353)	17.2 (437)	12.1 (307)	54.7	24.8
BV4-CS3-159			196.4	169.9					
BV4-CS3-330			437.3	378.2					
BV4-CS3-547			830.9	718.6					
BV4-CS3-2100			2,100.0*	1,816.3					

¹ - Weights are for valve bodies only.

- Largest Actuator dimension shown.

* Full Port Valves

For steam applications, install valve with stem at 45° to 90° from vertical.

BV - 2-Way Industrial Actuator Selection and Close-Off Chart

2-Way BV Actuator Selection/Close-Off (PSI) - 100 PSI Steam and 300 PSI Water										
On/Off & Floating			70-24-0061H	70-24-0201H	70-24-0501H	70-0061H	70-0121H	70-0201H	70-0301H	
			On-Off Tri-State 24VAC	On-Off Tri-State 24VAC	On-Off Tri-State 24VAC	On-Off Tri-State 120VAC	On-Off Tri-State 120VAC	On-Off Tri-State 120VAC	On-Off Tri-State 120VAC	
Modulating			70-24-0061SVH	70-24-0201SVH	70-24-0501SVH	70-0061SVH	70-0121SVH	70-0201SVH	70-0301SVH	
			0-10VDC 4-20mA 24VAC	0-10VDC 4-20mA 24VAC	0-10VDC 4-20mA 24VAC	0-10VDC 4-20mA 120VAC	0-10VDC 4-20mA 120VAC	0-10VDC 4-20mA 120VAC	0-10VDC 4-20mA 120VAC	
Valve Models	Size		Flow Coefficient		Series 70 - 24VAC			Series 70 - 120VAC		
	in.	mm	Cv	Kv						
BV05-CS3-04	1/2	15	4.2	3.6	100 PSI Steam			100 PSI Steam		
BV05-CS3-05			5.6	4.8						
BV05-CS3-09			12.8	11.1		300 PSI Water				
BV05-CS3-12			14.7	12.7						
BV05-CS3-32			32.0*	27.7						
BV75-CS3-05	3/4	20	5.5	4.8	100 PSI Steam			100 PSI Steam		
BV75-CS3-06			7.3	6.3						
BV75-CS3-12			16.3	10.7		300 PSI Water				
BV75-CS3-15			19.3	16.7						
BV75-CS3-54			54.0*	46.7						
BV1-CS3-09	1	25	9.8	8.5	100 PSI Steam			100 PSI Steam		
BV1-CS3-13			15.5	13.4						
BV1-CS3-23			32.8	28.4		300 PSI Water				
BV1-CS3-31			43.9	38.0						
BV1-CS3-105			105.0*	90.8						
BV125-CS3-11	1.25	32	12.8	11.1	100 PSI Steam			100 PSI Steam		
BV125-CS3-15			17.4	15.0						
BV125-CS3-33			43.5	37.6		300 PSI Water				
BV125-CS3-52			65.8	56.9						
BV125-CS3-200			200.0*	173.0						
BV150-CS3-15	1.50	40	17.6	15.2	100 PSI Steam			100 PSI Steam		
BV150-CS3-20			23.9	20.7						
BV150-CS3-46			59.7	51.6		300 PSI Water				
BV150-CS3-71			90.5	78.3						
BV150-CS3-275			275.0*	237.8						
BV2-CS3-29	2	50	34.7	30.0	100 PSI Steam			100 PSI Steam		
BV2-CS3-48			55.9	48.3						
BV2-CS3-104			135.8	117.5		300 PSI Water				
BV2-CS3-130			167.3	144.7						
BV2-CS3-500			500.0*	432.4						
BV250-CS3-27	2.50	65	31.3	27.1	100 PSI Steam			100 PSI Steam		
BV250-CS3-56			77.0	66.6						
BV250-CS3-114			162.5	140.5		300 PSI Water				
BV250-CS3-177			239.5	207.1						
BV250-CS3-780			780.0*	674.6						
BV3-CS3-32	3	80	38.3	33.1	100 PSI Steam			100 PSI Steam		
BV3-CS3-70			85.9	74.3						
BV3-CS3-150			193.2	167.1		300 PSI Water				
BV3-CS3-237			359.2	310.7						
BV3-CS3-1150			1,150.0*	994.6						
BV4-CS3-76	4	100	96.4	83.4	100 PSI Steam			100 PSI Steam		
BV4-CS3-159			196.4	169.9						
BV4-CS3-330			437.3	378.2		300 PSI Water				
BV4-CS3-547			830.9	718.6						
BV4-CS3-2100			2,100.0*	1,816.3						

V-port ball valves are controllable between 20% and 80% of full open.
 * Full Port Valves
 For steam applications, install valve with stem at 45° to 90° from vertical.

Key
 BV1-CS3-10 = Industrial Ball Valve Series BV 1 CS3 10 Cv
 Size (in.) Material Cv
 CS3 = Carbon Steel