

CONVECTOR KNOB DAMPER INSTALLATION INSTRUCTIONS

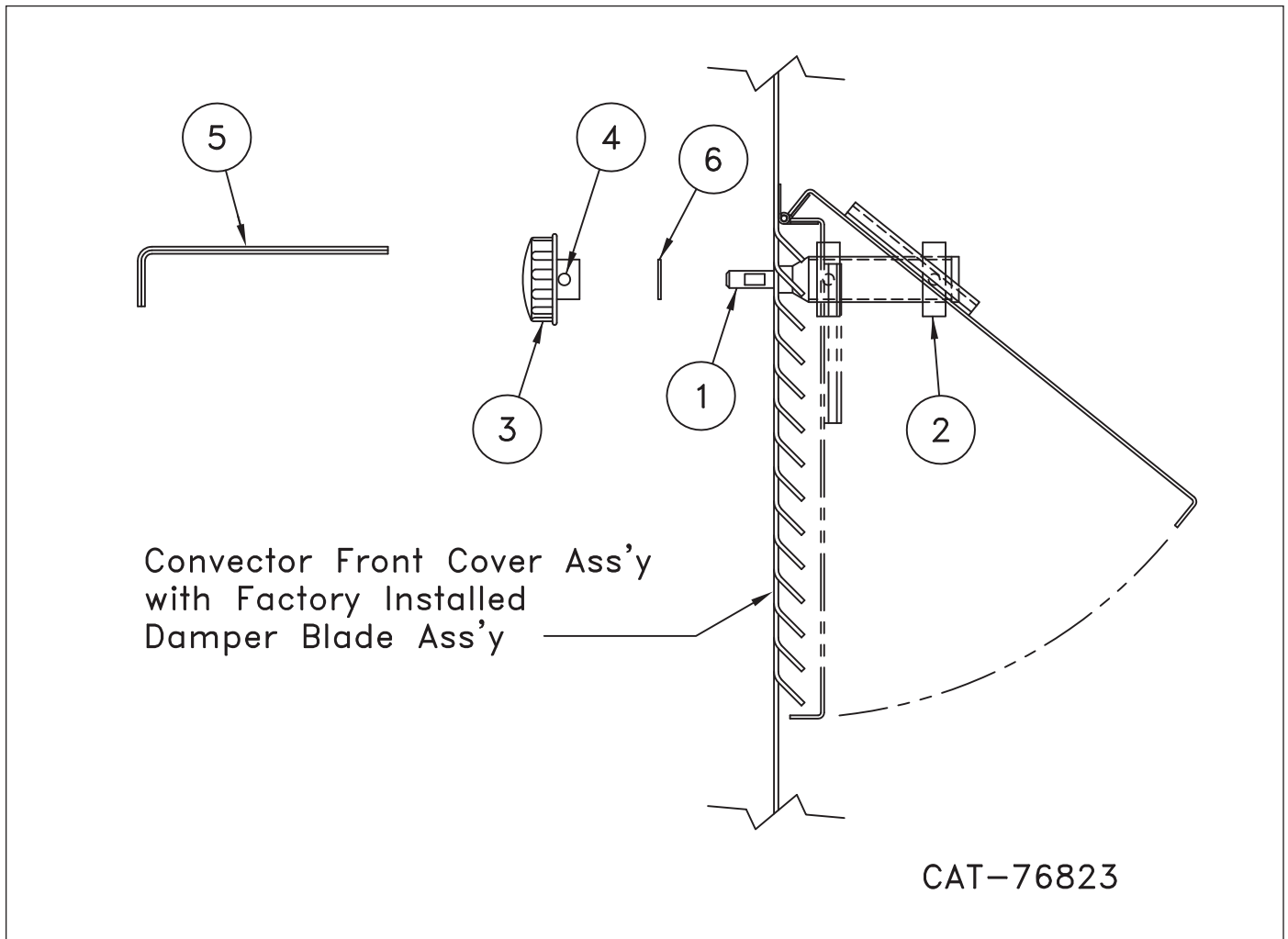

INSTALLATION STEPS:

1. Place enclosure on bench or horses.
2. Screw damper screw (1) into nut ass'y (2), to limit of screw.
3. Insert nut ass'y (with screw) into blade so that nut pins are between guides and blade.
4. Insert screw shaft into enclosure hole. Place washer on shaft. Holding screw firmly against enclosure, place knob (3) on shaft and tighten set screw (4) against flat of shaft.

PARTS LIST - SHIPPED LOOSE

1. Damper Screw - J21-04718
2. Nut Ass'y - E06-02342
3. Damper Knob - J37-15138
4. Set Screw #8-32 x 5/64 - J21-05718
5. Hex Wrench 5/64 - J24-02301
6. Brass Washer - J24-00322-010



A MESTEK COMPANY
www.mestek.com