

INSTALLATION INSTRUCTIONS & PARTS LIST

VERTICAL STEAM AND HOT WATER UNIT HEATERS

ATTENTION: READ THIS MANUAL AND ALL LABELS ATTACHED TO THE UNIT CAREFULLY BEFORE ATTEMPTING TO INSTALL, OPERATE OR SERVICE THESE UNITS! CHECK UNIT DATA PLATE FOR TYPE OF GAS AND ELECTRICAL SPECIFICATIONS AND MAKE CERTAIN THAT THESE AGREE WITH THOSE AT POINT OF INSTALLATION. RECORD THE UNIT MODEL AND SERIAL No.(s) IN THE SPACE PROVIDED. RETAIN FOR FUTURE REFERENCE.

Model No. _____ Serial No. _____

▲ WARNING Improper installation, adjustment, alteration, service or maintenance can cause property damage, injury or death. Read the installation, operating and maintenance instructions thoroughly before installing or servicing this equipment.



INSTALLER'S RESPONSIBILITY

Installer Please Note: This equipment has been tested and inspected. It has been shipped free from defects from our factory. However, during shipment and installation, problems such as loose wires, leaks or loose fasteners may occur. **It is the installer's responsibility to inspect and correct any problems that may be found.**

RECEIVING INSTRUCTIONS

Inspect shipment immediately when received to determine if any damage has occurred to the unit during shipment. After the unit has been uncrated, check for any visible damage to the unit. Turn fan by hand to determine if damage has occurred. If any damage is found, the consignee should sign the bill of lading indicating such damage and immediately file claim for damage with the transportation company.



MESTEK, INC.

260 NORTH ELM ST., WESTFIELD, MA 01085

TEL: (413) 568-9571 FAX: (413) 562-8437

www.mestek.com



TABLE OF CONTENTS

GENERAL SAFETY INFORMATION	3	ELECTRICAL CONNECTIONS	20
SPECIFICATIONS		Operation	20
Dimensional Data	4	Thermostat Wiring and Location	20
Mounting Specifications	3, 4, 7, 15-18, 27	Motors	20
Steam Performance Data	5, 6	WIRING INSTALLATION	21, 22
Steam Calculations & Correction Factors	7	OPTIONS	23
Hot Water Performance Data	8-11	MAINTENANCE	24
Hot Water Calculations & Correction Factors	12	TROUBLESHOOTING GUIDE	25
Technical Data	13	INSPECTION SHEET	25
Motor Data	14	WARRANTY	26
INSTALLATION		OSHA FAN GUARD/LOUVER CONE DIFFUSER	
Locating Units	15-18	INSTALLATION	27
Piping	19		

NOTICE: It is the owner's responsibility to provide any scaffolding or other apparatus required to perform emergency service or annual/periodic maintenance to this equipment.

DESCRIPTION

Vertical hydronic unit heaters are designed for installation requiring down flow air delivery, offered in 15 sizes ranging from 41,300 to 705,000 BTU/Hr., and use with steam or hot water. Low output (increased airflow) units are available for

high ceiling applications. The designs are certified by ETL. **Do not alter these units in any way and do not attach any ductwork to these units.** If you have any questions after reading this manual, contact the manufacturer.

Figure 1



Figure 2



The following terms are used throughout this manual, in addition to ETL requirements, to bring attention to the presence of potential hazards or to important information concerning the product:

▲ DANGER Indicates an imminently hazardous situation which, if not avoided, will result in death, serious injury or substantial property damage.

▲ WARNING Indicates an imminently hazardous situation which, if not avoided, could result in death, serious injury or substantial property damage.

▲ CAUTION Indicates an imminently hazardous situation which, if not avoided, may result in minor injury or property damage.

NOTICE: Used to notify of special instructions on installation, operation or maintenance which are important to equipment but not related to personal injury hazards.

GENERAL SAFETY INFORMATION

▲ WARNING Failure to comply with the general safety information may result in extensive property damage, severe personal injury or death.

▲ WARNING Do not alter the unit heater in any way or damage to the unit and/or severe personal injury or death may occur!

▲ WARNING Disconnect all power supplies before installing or servicing the heater. If the power disconnect is out of sight, lock it in the open position and tag it to prevent unexpected application of power. Failure to do so could result in fatal electric shock, or severe personal injury.

▲ CAUTION Ensure that all power sources conform to the requirements of the unit heater or damage to the unit will result!

Follow installation instructions CAREFULLY to avoid creating unsafe conditions. All external wiring must conform to applicable current local codes, and to the latest edition of the National Electric Code, ANSI/NFPA No. 70. In Canada, all external wiring must conform to the Canadian Electric Code, Part 1 CSA Standard C22.1. All wiring should be done and checked by a qualified electrician, using copper wire only. All steam or water connections should be made and leak-tested by a suitably qualified individual, per instructions in this manual. Also follow procedures listed on the "Unit Equipment Start-Up Sheet" located in this manual.

Make certain that the power source conforms to the electrical requirements of the heater.

▲ WARNING Do not depend upon a thermostat or other switch as sole means of disconnecting power when installing or servicing heater. Always disconnect power at main circuit breaker as described above. Failure to do so could result in fatal electric shock.

Special attention must be given to any grounding information pertaining to this heater. To reduce the risk of electrocution, the heater must be securely and adequately grounded. This should be accomplished by connecting a grounded conductor between the service panel and the heater. To ensure a proper ground, the grounding means must be tested by a qualified electrician.

Do not insert fingers or foreign objects into the heater or its air moving device. Do not block or tamper with the heater in any manner while in operation or just after it has been turned off, as some parts may be hot enough to cause injury.

It is recommended to install a shutoff switch in the electrical power lines at the heater. Whenever a unit is serviced, shut power off to the unit.

Since these units are installed in most instances higher than 8 feet, proper type of ladders or scaffolding should be used, as set up by OSHA requirements; see notice on page 2. Never place a ladder against the unit for support.

In industrial plants, professional maintenance crews should service this equipment.

All Vertical Unit Heaters are shipped fully assembled and may be used for steam or hot water applications. Coils are factory tested at 400 psig air under water. Fans are balanced and motors are prelubricated.

Each unit is packaged individually and marked for proper identification. Use normal care in handling and during installation to prevent damage to the coils fins, fan and casing. Do not set Vertical Unit Heater on floor with the weight of the unit resting against the fan blades. In this position, the blades may be damaged.

Unless otherwise specified, the following conversions may be used for calculating SI unit measurements:	
1 foot = 0.305 m	1 inch water column = 0.249 kPa
1 inch = 25.4 mm	meter/second = FPM ÷ 196.8
1 psig = 6.894 kPa	liter/second = CFM x 0.472
1 pound = 0.453 kg	1000 Btu per hour = 0.293 kW
1 gallon = 3.785 L	1000 Btu/Cu. Ft. = 37.5 MJ/m ³
	1 cubic foot = 0.028 m ³

To meet ETL and OSHA requirements, units mounted below 8 feet from the floor must be equipped with an OSHA fan guard.

DIMENSIONAL DATA

Figure 3 - Models 40-77

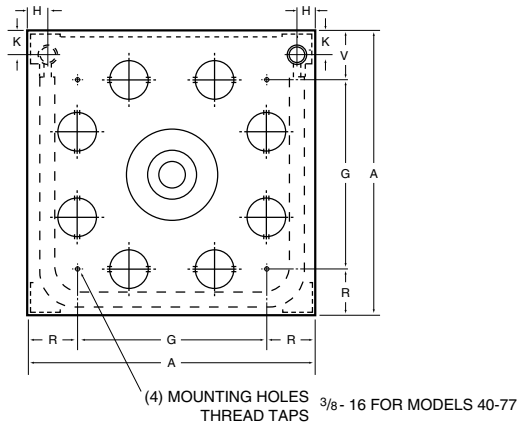

Figure 4 - Models 104-700

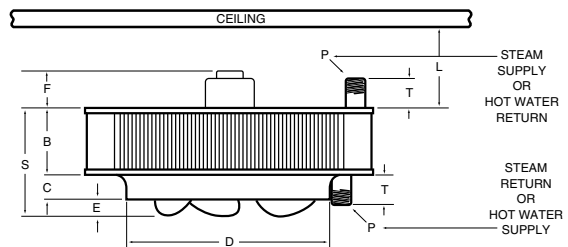
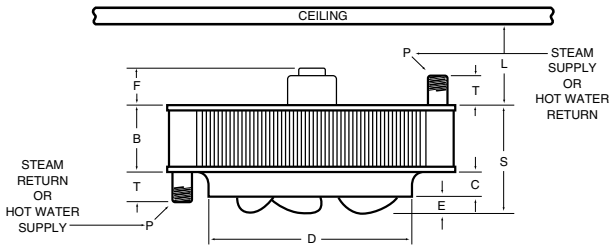
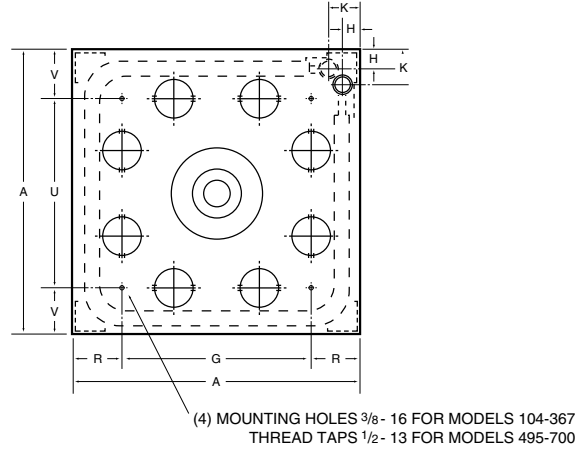

Table 1 – Figure 3 Roughing in Dimensional Data – Model Size 40-77

Unit Capacity (MBH)	Fan Dia.	A	B	C	D	E	F	G	H	K	L (Min)	P (NPT)	R	S	T	U	V
040	11 ¹ / ₄	18 ¹ / ₄	4 ⁵ / ₈	1 ¹ / ₄	11 ³ / ₄	3 ³ / ₄	4	11	1 ³ / ₈	1 ⁷ / ₈	7	1 ¹ / ₂	3 ⁵ / ₈	6 ⁵ / ₈	2 ³ / ₄	11	3 ⁵ / ₈
062	13 ¹ / ₂	21 ¹ / ₄	4 ⁵ / ₈	1 ⁵ / ₈	14	1	4	14	1 ³ / ₈	1 ⁷ / ₈	7	1 ¹ / ₂	3 ⁵ / ₈	7 ¹ / ₈	2 ³ / ₄	14	3 ⁵ / ₈
077	13 ¹ / ₂	21 ¹ / ₄	6 ¹ / ₈	1 ⁵ / ₈	14	1	3	14	1 ³ / ₈	1 ⁷ / ₈	7	1 ¹ / ₂	3 ⁵ / ₈	8 ⁵ / ₈	2 ³ / ₄	14	3 ⁵ / ₈

Table 2 - Figure 4 Roughing in Dimensional Data – Model Size 104-700

Unit Capacity (MBH)	Fan Dia.	A	B	C	D	E	F	G	H	K	L (Min)	P (NPT)	R	S	T	U	V
104	16 ³ / ₄	25 ¹ / ₄	6 ¹ / ₈	2	17 ¹ / ₂	1 ¹ / ₈	3	17	1 ³ / ₈	2 ³ / ₄	7	1 ¹ / ₂	4 ¹ / ₈	9 ¹ / ₈	2 ³ / ₄	17	4 ¹ / ₈
125	16 ³ / ₄	25 ¹ / ₄	6 ¹ / ₈	2	17 ¹ / ₂	1 ³ / ₄	3	17	1 ³ / ₈	2 ³ / ₄	7	1 ¹ / ₂	4 ¹ / ₈	9 ³ / ₄	2 ³ / ₄	17	4 ¹ / ₈
144	19 ³ / ₄	29 ¹ / ₂	6 ¹ / ₈	2 ³ / ₈	20 ⁵ / ₈	1 ¹ / ₄	4	20 ¹ / ₂	1 ³ / ₄	3 ¹ / ₂	7	2	4 ¹ / ₂	9 ⁵ / ₈	2 ³ / ₄	20 ¹ / ₂	4 ¹ / ₂
164	19 ³ / ₄	29 ¹ / ₂	6 ¹ / ₈	2 ³ / ₈	20 ⁵ / ₈	1 ³ / ₄	4	20 ¹ / ₂	1 ³ / ₄	3 ¹ / ₂	7	2	4 ¹ / ₂	10 ¹ / ₈	2 ³ / ₄	20 ¹ / ₂	4 ¹ / ₂
200	19 ³ / ₄	29 ¹ / ₂	7 ⁵ / ₈	2 ³ / ₈	20 ⁵ / ₈	2	4	20 ¹ / ₂	1 ³ / ₄	3 ¹ / ₂	7	2	4 ¹ / ₂	12	2 ³ / ₄	20 ¹ / ₂	4 ¹ / ₂
237	25 ¹ / ₄	37 ¹ / ₂	7 ⁵ / ₈	3	26 ³ / ₈	1	3 ¹ / ₂	28	1 ³ / ₄	3 ¹ / ₂	7	2	4 ³ / ₄	11 ⁵ / ₈	2 ³ / ₄	18	9 ³ / ₄
285	25 ¹ / ₄	37 ¹ / ₂	7 ⁵ / ₈	3	26 ³ / ₈	1 ¹ / ₄	3 ¹ / ₂	28	1 ³ / ₄	3 ¹ / ₂	7	2	4 ³ / ₄	11 ³ / ₄	2 ³ / ₄	18	9 ³ / ₄
317	25 ¹ / ₄	37 ¹ / ₂	7 ⁵ / ₈	3	26 ³ / ₈	2 ¹ / ₈	4	28	1 ³ / ₄	3 ¹ / ₂	7	2	4 ³ / ₄	12 ³ / ₄	2 ³ / ₄	18	9 ³ / ₄
367	25 ¹ / ₄	37 ¹ / ₂	9 ¹ / ₈	3	26 ³ / ₈	2	3 ¹ / ₂	28	1 ³ / ₄	3 ¹ / ₂	7	2	4 ³ / ₄	14 ¹ / ₈	2 ³ / ₄	18	9 ³ / ₄
495	30 ¹ / ₂	42	9 ¹ / ₈	3 ¹ / ₂	31 ¹ / ₄	1 ⁵ / ₈	3	30	2 ¹ / ₄	4 ¹ / ₄	7	2 ¹ / ₂	6	14 ¹ / ₄	3	30	6
585	30 ¹ / ₂	42	12 ¹ / ₈	3 ¹ / ₂	31 ¹ / ₄	2 ¹ / ₈	3	30	2 ¹ / ₄	4 ¹ / ₄	7	2 ¹ / ₂	6	17 ³ / ₄	3	30	6
700	30 ¹ / ₂	42	13 ⁵ / ₈	3 ¹ / ₂	31 ¹ / ₄	3	4	30	2 ¹ / ₄	4 ¹ / ₄	7	2 ¹ / ₂	6	20 ¹ / ₄	3	30	6

STEAM PERFORMANCE DATA**

Table 3 - Standard Units

Unit Capacity (MBH)	Output BTU/HR (kW)	Condensate lbs/hr (kg/hr)	EDR Sq. ft. (Sq. m)	Final Air Temp °F (°C)	Motor		Nominal CFM (m ³ /s)	Outlet Velocity FPM (m/s)	Sound Rating
					HP (kW)	RPM			
040	41,300	43	172	124			595	877	I
	(12.1)	(19.5)	(16.0)	(51)	1/40		(.278)	(4.455)	
	<i>33,600</i>	<i>55</i>	<i>140</i>	<i>131</i>	(.019)	<i>1150</i>	<i>436</i>	<i>658</i>	
	<i>(9.8)</i>	<i>(24.9)</i>	<i>(13.0)</i>	<i>(55)</i>			<i>(.203)</i>	<i>(3.343)</i>	
062	65,500	68	273	121			989	1005	II
	(19.2)	(30.8)	(25.4)	(49)	1/20		(.462)	(5.105)	
	<i>52,800</i>	<i>55</i>	<i>220</i>	<i>129</i>	(.037)	<i>1150</i>	<i>706</i>	<i>727</i>	
	<i>(15.5)</i>	<i>(24.9)</i>	<i>(20.5)</i>	<i>(54)</i>			<i>(.329)</i>	<i>(3.693)</i>	
077	80,600	83	336	122			1200	1220	II
	(23.6)	(37.6)	(31.3)	(50)	1/20		(.560)	(6.198)	
	<i>65,100</i>	<i>67</i>	<i>271</i>	<i>130</i>	(.037)	<i>1150</i>	<i>858</i>	<i>894</i>	
	<i>(19.1)</i>	<i>(30.4)</i>	<i>(25.2)</i>	<i>(54)</i>			<i>(.400)</i>	<i>(4.542)</i>	
104	101,800	106	424	123			1490	980	II
	(29.8)	(48.0)	(39.4)	(51)	1/8		(.695)	(4.978)	
	<i>87,900</i>	<i>91</i>	<i>366</i>	<i>129</i>	(.093)	<i>850</i>	<i>1180</i>	<i>783</i>	
	<i>(25.8)</i>	<i>(41.2)</i>	<i>(34.0)</i>	<i>(54)</i>			<i>(.551)</i>	<i>(3.978)</i>	
125	124,400	129	518	124	1/6	1100	1790	1170	III
	(36.4)	(58.4)	(48.2)	(51)	(.124)		(.835)	(5.944)	
144	152,000	157	633	123	1/6	1100	2220	1045	III
	(44.5)	(71.1)	(58.9)	(51)	(.124)		(1.036)	(5.309)	
164	173,000	179	720	121	1/6	1100	2620	1230	IV
	(50.7)	(81.1)	(67.0)	(49)	(.124)		(1.223)	(6.248)	
200	210,200	208	838	118	1/4	1100	3200	1495	III
	(61.6)	(94.2)	(78.0)	(48)	(.186)		(1.493)	(7.595)	
237	249,800	260	1040	115	1/4	1100	4180	1205	IV
	(73.2)	(117.8)	(96.7)	(46)	(.186)		(1.951)	(6.121)	
285	283,800	294	1180	119	1/2	1100	4430	1275	IV
	(83.2)	(133.2)	(109.8)	(48)	(.373)		(2.067)	(6.477)	
317	333,400	345	1390	119	3/4	1140	5210	1500	IV
	(97.7)	(156.3)	(129.3)	(48)	(.559)		(2.431)	(7.620)	
367	386,000	400	1610	118	3/4	1140	6140	1770	IV
	(113.1)	(181.2)	(149.8)	(48)	(.559)		(2.865)	(8.992)	
495	496,000	514	2070	117	1-1/2	1175	8020	1640	IV
	(145.3)	(232.8)	(192.6)	(47)	(1.119)		(3.743)	(8.331)	
585	585,000	605	2440	117	1-1/2	1175	9450	1930	IV
	(171.4)	(274.1)	(227.0)	(47)	(1.119)		(4.410)	(9.804)	
700	705,000	729	2940	119	3	1165	11,000	2250	IV
	(206.6)	(330.2)	(273.5)	(48)	(2.237)		(5.133)	(11.430)	

EDR = Equivalent Direct Radiation

NOTES:

Constant speed units are rated at capacities shown in regular type; capacities shown in italic faced type apply only to units with multi-speed motors.

** Performance data based on 2 lbs. steam pressure at heater with air entering @60°F.

To determine BTU per hour capacities at various steam pressures and entering air temperatures, use correction factors from Table 5. Final temperatures at new conditions can be calculated by applying basic formula.

STEAM PERFORMANCE DATA**

Table 4 - "Low Output" Standard Vertical Units with All Air Ports Open

Unit Capacity (MBH)	Output BTU/HR (kW)	Condensate lbs/hr (kg/hr)	EDR Sq. ft. (Sq. m)	Final Air Temp °F °C	Motor		Nominal CFM (m³/s)	Outlet Velocity FPM (m/s)	Sound Rating
					HP (kW)	RPM			
040L	34,800 (10.2)	36 (16.3)	145 (13.5)	108 (42)	1/40 (.019)	1550	668 (.312)	950 (4.826)	I
	<i>26,000</i> (7.6)	<i>27</i> (12.2)	<i>108</i> (10.0)	<i>111</i> (44)			<i>470</i> (.219)	<i>672</i> (3.414)	
062L	57,200 (16.8)	59 (26.7)	238 (22.1)	104 (40)	1/20 (.037)	1550	1200 (.560)	1190 (6.045)	I
	<i>45,800</i> (13.4)	<i>48</i> (21.7)	<i>191</i> (17.8)	<i>109</i> (43)			<i>862</i> (.402)	<i>858</i> (4.359)	
077L	68,000 (19.9)	71 (32.2)	283 (26.3)	106 (41)	1/20 (.037)	1550	1360 (.635)	1350 (6.858)	II
	<i>55,000</i> (16.1)	<i>57</i> (25.8)	<i>229</i> (21.3)	<i>111</i> (44)			<i>995</i> (.464)	<i>992</i> (5.039)	
104L	85,400 (25.0)	89 (40.3)	356 (33.1)	108 (42)	1/8 (.093)	1070	1640 (.765)	1050 (5.334)	II
	<i>71,200</i> (20.9)	<i>74</i> (33.5)	<i>296</i> (27.5)	<i>111</i> (44)			<i>1290</i> (.602)	<i>827</i> (4.201)	
125L	111,000 (32.5)	115 (52.1)	462 (43.0)	107 (42)	1/6 (.124)	1100	2180 (1.017)	1390 (7.061)	III
144L	125,000 (36.6)	130 (58.9)	524 (48.7)	109 (43)	1/6 (.124)	1100	2360 (1.101)	1080 (5.486)	III
164L	149,000 (43.7)	154 (69.8)	620 (57.7)	107 (42)	1/6 (.124)	1100	2920 (1.363)	1340 (6.807)	IV
200L	176,800 (51.8)	183 (82.9)	736 (68.5)	108 (42)	1/4 (.186)	1100	3390 (1.582)	1560 (7.925)	III
237L	214,900 (63.0)	224 (101.5)	895 (83.3)	104 (40)	1/4 (.186)	1100	4500 (2.100)	1270 (6.452)	IV
285L	251,800 (73.8)	260 (117.8)	1050 (97.7)	106 (41)	1/2 (.373)	1100	5040 (2.352)	1420 (7.214)	IV
317L	291,000 (85.3)	302 (136.8)	1210 (112.6)	107 (42)	3/4 (.559)	1140	5700 (2.660)	1610 (8.179)	IV
367L	344,000 (100.8)	356 (161.3)	1430 (133.0)	108 (42)	3/4 (.559)	1140	6600 (3.080)	1870 (9.500)	IV
495L	428,000 (125.4)	446 (202.0)	1785 (166.0)	102 (39)	1-1/2 (1.119)	1175	9380 (4.377)	1860 (9.449)	IV
585L	515,000 (150.9)	533 (241.4)	2140 (199.1)	106 (41)	1-1/2 (1.119)	1175	10,300 (4.807)	2060 (10.465)	IV
700L	620,000 (181.7)	642 (290.8)	2580 (240.0)	108 (42)	3 (2.237)	1165	11,900 (5.553)	2380 (12.090)	IV

EDR = Equivalent Direct Radiation

NOTES:

Constant speed units are rated at capacities shown in regular type; capacities shown in italic faced type apply only to units with multi-speed motors.

** Performance data based on 2 lbs. steam pressure at heater with air entering @60°F.

To determine BTU per hour capacities at various steam pressures and entering air temperatures, use correction factors from Table 5. Final temperatures at new conditions can be calculated by applying basic formula.

STEAM CALCULATIONS AND CORRECTION FACTORS

EXAMPLE: –
 UNIT SIZE _____ 40
 Steam Pressure ____ 10 PSI
 Entering Air Temp. __ 40°F

I. CAPACITY		
A. For 2 lbs. steam, 60°F entering air	Read output directly from Table 3: 41,300 BTU/HR.	
B. For higher steam pressures and/or EAT's above or below 60°F	Multiply output from Table 3 by appropriate correction factor from Table 5 (below).	41,300 x 1.27 = 52,451 BTU/HR.
II. FINAL AIR TEMPERATURE		
A. For 2 lbs. steam, 60°F entering air	Read temperature directly from Table 3: 124°F.	
B. For capacities calculated in IB (above)	$\frac{\text{Output from IB}}{1.085 \times \text{CFM from Table 3}} + \text{EAT} = \text{Final Air Temp}$	$\frac{52,451}{1.085 \times 595} + 40 = 121.0^\circ\text{F}$
III. FINAL AIR VOLUME		
A. For 2 lbs. steam, 60°F entering air	$\frac{460 + \text{Final Air Temp from Table 3}}{530} \times \frac{\text{Nom. CFM from Table 3}}{\text{Final Air Volume}} = \text{Air Volume}$	$\frac{460 + 124}{530} \times 595 = 655 \text{ CFM}$
B. For final air temperatures calculated in IIB (above)	$\frac{460 + \text{Final Air Temp from IIB}}{530} \times \frac{\text{Nom. CFM from Table 3}}{\text{Final Air Volume}} = \text{Air Volume}$	$\frac{460 + 121.0}{530} \times 595 = 652 \text{ CFM}$
IV. CONDENSATE PER HOUR		
A. For 2 lbs. steam, 60°F entering air	Read lbs. per hour from Table 3: 43 LBS./HR.	
B. For capacities calculated in IB (above)	$\frac{\text{Output from IB}}{\text{Latent Heat From Table 6}} = \text{lbs. per hour of condensate}$	$\frac{52,451}{953} = 55.0 \text{ LBS./HR.}$

TABLE 5 — STEAM CORRECTION FACTORS BASED ON 2 LBS. STEAM 60°F EAT

ENTERING AIR TEMPERATURE °F (°C)	STEAM PRESSURE — LBS PER SQUARE INCH (SATURATED)									
	0 (.0)	2 (13.8)	5 (34.5)	10 (68.9)	15 (103.4)	20 (137.9)	30 (206.8)	40 (275.8)	50 (344.7)	75 (517.1)
30° (-1°)	1.18	1.22	1.27	1.34	1.40	1.45	1.53	1.61	1.67	1.79
40° (4°)	1.11	1.15	1.20	1.27	1.32	1.37	1.46	1.53	1.59	1.71
50° (10°)	1.03	1.07	1.12	1.19	1.25	1.30	1.39	1.46	1.52	1.64
60° (16°)	0.96	1.00	1.05	1.12	1.18	1.23	1.32	1.39	1.45	1.57
70° (21°)	0.90	0.93	0.98	1.05	1.11	1.16	1.25	1.32	1.38	1.49
80° (27°)	0.83	0.86	0.91	0.98	1.04	1.09	1.18	1.25	1.31	1.42
90° (32°)	0.76	0.80	0.85	0.91	0.97	1.02	1.11	1.18	1.24	1.36
100° (38°)	0.69	0.73	0.78	0.85	0.90	0.96	1.04	1.11	1.17	1.29

TABLE 6 — PROPERTIES OF SATURATED STEAM

	STEAM PRESSURE IN LBS PER SQUARE INCH GAUGE									
	0 (.0)	2 (13.8)	5 (34.5)	10 (68.9)	15 (103.4)	20 (137.9)	30 (206.8)	40 (275.8)	50 (344.7)	75 (517.1)
Steam Temperature-°F (°C)	212.0 (100.0)	218.5 (103.6)	227.1 (108.4)	239.4 (115.2)	249.8 (121.0)	258.8 (126.0)	274.0 (134.4)	286.7 (141.5)	297.7 (147.6)	319.9 (159.9)
Latent Heat of Steam-Btu/lbm (KJ/Kg)	970 (2256)	966 (2247)	961 (2235)	953 (2217)	946 (2200)	940 (2186)	929 (2161)	920 (2140)	912 (2121)	891 (2072)

NOTE 1: Ratings apply only to free inlet and discharge without diffusers.

NOTE 2: All motors are constant speed and operate at top speed as indicated in motor data. Sizes 40 through 104 can be run at reduced speed with addition of optional variable speed switch. This switch is factory-calibrated for low and high speed ratings, with intermediate speeds infinitely controllable. Sizes 164 through 700 operate at constant speed as indicated in motor data.

NOTE 3: For specific motor data refer to motor specifications in Tables 13 and 14.

NOTE 4: To correct for entering air temperatures, use 1° temperature rise for each foot in mounting height. As an example, 60°F air is required at work area (5 ft. above floor) units are to be mounted at (20 ft.) above floor. Mounting height (20 ft.) minus work height (5 ft.) equals differential (15 ft.) or, 15° rise in air temperature at unit air inlet. Correct for actual inlet air temperature of 75°F (60°F + 15°F = 75°F EAT) on Table 5.

HOT WATER PERFORMANCE DATA**

Table 7 - Standard Output Units

Unit Capacity (MBH)	Water Temp Drop °F (°C)	Output MBH (kW)	Flow Rate GPM (L/s)	Pressure Drop ft/water (m/water)	Final Air Temp °F (°C)	Motor HP (kW)	Motor RPM	Nominal CFM (m³/s)	Outlet Velocity FPM (m/s)	Sound Rating
040	10° (5.6°)	28.8 (8.4)	5.93 (.374)	.37 (.113)	104.6° (40.3°)	1/40 (.019)	1550	595 (.278)	877 (4.455)	I
	20° (11.1°)	22.7 (6.7)	2.34 (.148)	.06 (.018)	95.2° (35.1°)					
	30° (16.7°)	16.7 (4.9)	1.15 (.073)	.02 (.006)	85.9° (29.9°)					
040*	10° (5.6°)	22.9 (6.7)	4.71 (.297)	.24 (.073)	108.3° (42.4°)	1/40 (.019)	1150	436 (.203)	658 (3.343)	I
	20° (11.1°)	18.1 (5.3)	1.87 (.118)	.04 (.012)	98.3° (36.8°)					
	30° (16.7°)	13.4 (3.9)	.92 (.058)	.01 (.003)	88.4° (31.3°)					
062	10° (5.6°)	48.1 (14.1)	9.92 (.626)	1.05 (.320)	104.8° (40.4°)	1/20 (.037)	1550	989 (.462)	1005 (5.105)	II
	20° (11.1°)	39.6 (11.6)	4.08 (.257)	.19 (.058)	96.9° (36.1°)					
	30° (16.7°)	31.1 (9.1)	2.14 (.135)	.06 (.018)	89.0° (31.7°)					
062*	10° (5.6°)	38.1 (11.2)	7.85 (.495)	.67 (.204)	109.7° (43.2°)	1/20 (.037)	1150	706 (.329)	727 (3.693)	II
	20° (11.1°)	31.5 (9.2)	3.24 (.204)	.13 (.040)	101.1° (38.4°)					
	30° (16.7°)	24.8 (7.3)	1.71 (.108)	.04 (.012)	92.4° (33.6°)					
077	10° (5.6°)	58.7 (17.2)	12.11 (.764)	.98 (.299)	105.1° (40.6°)	1/20 (.037)	1550	1200 (.560)	1220 (6.198)	II
	20° (11.1°)	48.4 (14.2)	4.99 (.315)	.18 (.055)	97.2° (36.2°)					
	30° (16.7°)	38.1 (11.2)	2.62 (.165)	.05 (.015)	89.3° (31.8°)					
077*	10° (5.6°)	46.5 (13.6)	9.59 (.605)	.63 (.192)	110.0° (43.3°)	1/20 (.037)	1150	858 (.400)	894 (4.542)	II
	20° (11.1°)	38.5 (11.3)	3.97 (.250)	.12 (.037)	101.2° (38.4°)					
	30° (16.7°)	30.5 (8.9)	2.09 (.132)	.03 (.009)	92.7° (33.7°)					
104	10° (5.6°)	77.2 (22.6)	15.91 (1.004)	2.06 (.628)	106.6° (41.4°)	1/8 (.093)	1070	1528 (.713)	980 (4.978)	II
	20° (11.1°)	68.3 (20.0)	7.03 (.443)	.44 (.134)	101.2° (38.4°)					
	30° (16.7°)	59.3 (17.4)	4.08 (.257)	.16 (.049)	95.8° (35.4°)					
104*	10° (5.6°)	63.7 (18.7)	13.13 (.828)	1.43 (.436)	108.6° (42.6°)	1/8 (.093)	850	1208 (.564)	783 (3.978)	II
	20° (11.1°)	56.5 (16.6)	5.82 (.367)	.31 (.095)	103.1° (39.5°)					
	30° (16.7°)	49.2 (14.4)	3.38 (.213)	.11 (.034)	97.6° (36.4°)					
125	10° (5.6°)	94.9 (27.8)	19.55 (1.233)	3.04 (.927)	108.9° (42.7°)	1/6 (.124)	1100	1790 (.835)	1170 (5.944)	III
	20° (11.1°)	83.7 (24.5)	8.63 (.544)	.65 (.198)	103.1° (39.5°)					
	30° (16.7°)	72.5 (21.2)	4.98 (.314)	.23 (.070)	97.3° (36.3°)					

**Performance based on 200°F EWT, 20°F TD, 60°F EAT. Performance at 10°F & 30°F TD is also shown. For capacities at other conditions, use the correction multipliers in the tables on page 12.

*Speed controller option is required for reduced ratings.

HOT WATER PERFORMANCE DATA**

Table 7 - Standard Output Units

Unit Capacity (MBH)	Water Temp Drop °F (°C)	Output MBH (kW)	Flow Rate GPM (L/s)	Pressure Drop ft/water (m/water)	Final Air Temp °F (°C)	Motor HP (kW)	Motor RPM	Nominal CFM (m³/s)	Outlet Velocity FPM (m/s)	Sound Rating
144	10° (5.6°)	117.6 (34.5)	24.24 (1.529)	4.32 (1.318)	108.8° (42.7°)	1/6 (.124)	1100	2220 (1.036)	1045 (5.309)	III
	20° (11.1°)	105.2 (30.8)	10.84 (.684)	.96 (.293)	103.7° (39.8°)					
	30° (16.7°)	92.8 (27.2)	6.38 (.402)	.36 (.110)	98.5° (36.9°)					
164	10° (5.6°)	132.4 (38.8)	27.29 (1.722)	3.67 (1.119)	106.6° (41.4°)	1/6 (.124)	1100	2620 (1.223)	1230 (6.248)	IV
	20° (11.1°)	118.6 (34.7)	12.22 (.771)	.81 (.247)	101.7° (38.7°)					
	30° (16.7°)	104.8 (30.7)	7.20 (.454)	.30 (.092)	96.9° (36.1°)					
200	10° (5.6°)	156.2 (45.8)	32.20 (2.031)	5.02 (1.531)	105.0° (40.6°)	1/4 (.186)	1100	3200 (1.493)	1495 (7.595)	III
	20° (11.1°)	139.7 (40.9)	14.40 (.908)	1.11 (.339)	100.2° (37.9°)					
	30° (16.7°)	123.2 (36.1)	8.47 (.534)	.41 (.125)	95.5° (35.3°)					
237	15° (8.3°)	188.9 (55.3)	25.95 (1.637)	3.92 (1.196)	101.8° (38.8°)	1/4 (.186)	1100	4162 (1.942)	1205 (6.121)	IV
	20° (11.1°)	180.1 (52.8)	18.56 (1.171)	2.10 (.641)	99.9° (37.7°)					
	30° (16.7°)	162.7 (47.7)	11.18 (.705)	.82 (.250)	96.0° (35.6°)					
285	15° (8.3°)	215.4 (63.1)	29.60 (1.867)	5.02 (1.531)	104.8° (40.4°)	1/2 (.373)	1100	4430 (2.067)	1275 (6.477)	IV
	20° (11.1°)	205.4 (60.2)	21.17 (1.335)	2.68 (.817)	102.7° (39.3°)					
	30° (16.7°)	185.3 (54.3)	12.73 (.803)	1.04 (.317)	98.5° (36.9°)					
317	15° (8.3°)	254.9 (74.7)	35.03 (2.210)	6.88 (2.098)	105.1° (40.6°)	3/4 (.559)	1140	5210 (2.431)	1500 (7.620)	IV
	20° (11.1°)	242.9 (71.2)	25.03 (1.579)	3.67 (1.119)	103.0° (39.4°)					
	30° (16.7°)	218.9 (64.1)	15.04 (.949)	1.42 (.433)	98.7° (37.1°)					
367	15° (8.3°)	294.7 (86.3)	40.49 (2.554)	6.60 (2.013)	104.2° (40.1°)	3/4 (.559)	1140	6140 (2.865)	1770 (8.992)	IV
	20° (11.1°)	280.8 (82.3)	28.94 (1.826)	3.52 (1.074)	102.2° (39.0°)					
	30° (16.7°)	253.1 (74.2)	17.39 (1.097)	1.36 (.415)	98.0° (36.7°)					
495	20° (11.1°)	368.1 (107.9)	37.93 (2.393)	5.81 (1.772)	102.3° (39.1°)	1-1/2 (1.119)	1160	8020 (3.743)	1640 (8.331)	IV
	30° (16.7°)	333.6 (97.7)	22.92 (1.446)	2.29 (.698)	98.3° (36.8°)					
	15° (8.3°)	451.2 (132.2)	62.00 (3.911)	8.78 (2.678)	104.0° (40.0°)					
585	20° (11.1°)	431.1 (126.3)	44.43 (2.803)	4.72 (1.440)	102.0° (38.9°)	1-1/2 (1.119)	1160	9450 (4.410)	1930 (9.804)	IV
	30° (16.7°)	391.0 (114.6)	26.86 (1.694)	1.86 (.567)	98.1° (36.7°)					
	15° (8.3°)	519.4 (152.2)	53.52 (3.376)	5.29 (1.613)	103.5° (39.7°)					
700	20° (11.1°)	519.4 (152.2)	53.52 (3.376)	5.29 (1.613)	103.5° (39.7°)	3 (2.237)	1165	11,000 (5.133)	2250 (11.430)	IV
	30° (16.7°)	470.9 (138.0)	32.35 (2.041)	2.08 (.634)	99.5° (37.5°)					
	15° (8.3°)	619.4 (181.6)	70.00 (4.404)	11.00 (3.306)	106.0° (41.7°)					

**Performance based on 200°F EWT, 20°F TD, 60°F EAT. Performance at 10°F & 30°F TD is also shown.

For capacities at other conditions, use the correction multipliers in the tables on page 12.

*Speed controller option is required for reduced ratings.

HOT WATER PERFORMANCE DATA**

Table 8 - Low Output Units Standard Vertical Unit with All Air Ports Open

Unit Capacity (MBH)	Water Temp Drop °F (°C)	Output MBH (kW)	Flow Rate GPM (L/s)	Pressure Drop ft/water m/water	Final Air Temp °F (°C)	Motor HP (kW)	Motor RPM	Nominal CFM (m³/s)	Outlet Velocity FPM (m/s)	Sound Rating
040L	10° (5.6°)	23.9 (7.0)	4.92 (.310)	.26 (.079)	92.9° (33.8°)	1/40 (.019)	1550	668 (.312)	950 (4.826)	I
	20° (11.1°)	18.9 (5.5)	1.95 (.123)	.04 (.012)	86.1° (30.1°)					
	30° (16.7°)	14.0 (4.1)	.96 (.061)	.01 (.003)	79.3° (26.3°)					
040L*	10° (5.6°)	16.7 (4.9)	3.45 (.218)	.13 (.040)	92.8° (33.8°)	1/40 (.019)	1150	470 (.219)	672 (3.414)	I
	20° (11.1°)	13.5 (4.0)	1.39 (.088)	.02 (.006)	86.4° (30.2°)					
	30° (16.7°)	14.0 (4.1)	.96 (.061)	.01 (.003)	79.3° (26.3°)					
062L	10° (5.6°)	41.5 (12.2)	8.56 (.540)	.80 (.244)	91.9° (33.3°)	1/20 (.037)	1550	1200 (.560)	1190 (6.045)	II
	20° (11.1°)	34.2 (10.0)	3.53 (.223)	.15 (.046)	86.3° (30.2°)					
	30° (16.7°)	27.0 (7.9)	1.85 (.117)	.04 (.012)	80.7° (27.1°)					
062L*	10° (5.6°)	32.4 (9.5)	6.68 (.421)	.50 (.153)	94.7° (34.8°)	1/20 (.037)	1150	862 (.402)	858 (4.359)	II
	20° (11.1°)	26.9 (7.9)	2.77 (.175)	.09 (.027)	88.7° (31.5°)					
	30° (16.7°)	21.3 (6.2)	1.46 (.092)	.03 (.009)	82.8° (28.2°)					
077L	10° (5.6°)	48.9 (14.3)	10.09 (.637)	.69 (.210)	93.2° (34.0°)	1/20 (.037)	1550	1360 (.635)	1350 (6.858)	II
	20° (11.1°)	40.5 (11.9)	4.17 (.263)	.13 (.040)	87.4° (30.8°)					
	30° (16.7°)	32.0 (9.4)	2.20 (.139)	.04 (.012)	81.7° (27.6°)					
077L*	10° (5.6°)	38.5 (11.3)	7.94 (.501)	.44 (.134)	95.7° (35.4°)	1/20 (.037)	1150	995 (.464)	992 (5.039)	II
	20° (11.1°)	32.0 (9.4)	3.29 (.208)	.08 (.024)	89.6° (32.0°)					
	30° (16.7°)	25.4 (7.4)	1.75 (.110)	.02 (.006)	83.5° (28.6°)					
104L	10° (5.6°)	63.7 (18.7)	13.13 (.828)	1.43 (.463)	93.5° (34.2°)	1/8 (.093)	1070	1752 (.818)	1050 (5.334)	II
	20° (11.1°)	56.5 (16.6)	5.82 (.367)	.31 (.095)	89.7° (32.1°)					
	30° (16.7°)	49.2 (14.4)	3.38 (.213)	.11 (.034)	85.9° (29.9°)					
104L*	10° (5.6°)	54.5 (16.0)	11.24 (.709)	1.06 (.323)	93.5° (34.2°)	1/8 (.093)	850	1499 (.700)	827 (4.201)	II
	20° (11.1°)	48.5 (14.2)	4.99 (.315)	.23 (.070)	89.8° (32.1°)					
	30° (16.7°)	42.4 (12.4)	2.91 (.184)	.08 (.024)	86.1° (30.1°)					
125	10° (5.6°)	83.7 (24.5)	17.24 (1.088)	2.40 (.732)	95.4° (35.2°)	1/6 (.124)	1100	2180 (1.017)	1390 (7.061)	III
	20° (11.1°)	73.9 (21.7)	7.62 (.481)	.51 (.156)	91.3° (32.9°)					
	30° (16.7°)	64.2 (18.8)	4.41 (.278)	.18 (.055)	87.1° (30.6°)					

**Performance based on 200°F EWT, 20°F TD, 60°F EAT. Performance at 10°F & 30°F TD is also shown. For capacities at other conditions, use the correction multipliers in the tables on page 12.

*Speed controller option is required for reduced ratings.

HOT WATER PERFORMANCE DATA**

Table 8 - Low Output Units Standard Vertical Unit with All Air Ports Open

Unit Capacity (MBH)	Water Temp Drop °F (°C)	Output MBH (kW)	Flow Rate GPM (L/s)	Pressure Drop ft/water (m/water)	Final Air Temp °F (°C)	Motor HP (kW)	Motor RPM	Nominal CFM (m³/s)	Outlet Velocity FPM (m/s)	Sound Rating
144L	10° (5.6°)	95.4 (28.0)	19.66 (1.240)	2.92 (.891)	97.3° (36.3)	1/6 (.124)	1100	2360 (1.101)	1080 (5.486)	III
	20° (11.1°)	85.5 (25.1)	8.81 (.556)	.65 (.198)	93.4° (34.1)					
	30° (16.7°)	75.6 (22.2)	5.20 (.328)	.24 (.073)	89.5° (31.9)					
164L	10° (5.6°)	112.3 (32.9)	23.15 (1.460)	2.70 (.824)	95.4° (35.2)	1/6 (.124)	1100	2920 (1.363)	1340 (6.807)	IV
	20° (11.1°)	100.7 (29.5)	10.38 (.655)	.60 (.183)	91.8° (33.2)					
	30° (16.7°)	89.2 (26.1)	6.13 (.387)	.22 (.067)	88.1° (31.2)					
200L	10° (5.6°)	135.8 (39.8)	27.98 (1.765)	3.85 (1.174)	96.9° (36.1)	1/4 (.186)	1100	3390 (1.582)	1560 (7.925)	III
	20° (11.1°)	121.8 (35.7)	12.52 (.790)	.85 (.259)	93.0° (33.9)					
	30° (16.7°)	107.3 (31.4)	7.37 (.465)	.32 (.098)	89.2° (31.8)					
237L	10° (5.6°)	168.5 (49.4)	34.72 (2.190)	6.75 (2.059)	94.5° (34.7)	1/4 (.186)	1100	4507 (2.103)	1270 (6.452)	IV
	20° (11.1°)	153.8 (45.1)	15.85 (1.000)	1.56 (.476)	91.4° (33.0)					
	30° (16.7°)	139.1 (40.8)	9.56 (.603)	.61 (.186)	88.4° (31.3)					
285L	10° (5.6°)	188.9 (55.3)	25.95 (1.637)	3.92 (1.196)	94.5° (34.7)	1/2 (.373)	1100	5040 (2.352)	1420 (7.214)	IV
	20° (11.1°)	180.1 (52.8)	18.56 (1.171)	2.10 (.641)	92.9° (33.8)					
	30° (16.7°)	162.7 (47.7)	11.18 (.705)	.82 (.250)	89.7° (32.1)					
317L	10° (5.6°)	220.9 (64.7)	30.35 (1.915)	5.26 (1.604)	95.7° (35.4)	3/4 (.559)	1140	5700 (2.660)	1610 (8.179)	IV
	20° (11.1°)	210.6 (61.7)	21.70 (1.369)	2.81 (.857)	94.1° (34.5)					
	30° (16.7°)	189.9 (55.6)	13.05 (.823)	1.09 (.332)	90.7° (32.6)					
367L	10° (5.6°)	260.7 (76.4)	35.82 (2.260)	5.24 (1.598)	96.4° (35.8)	3/4 (.559)	1140	6600 (3.080)	1870 (9.500)	IV
	20° (11.1°)	248.5 (72.8)	25.61 (1.616)	2.80 (.854)	94.7° (34.8)					
	30° (16.7°)	224.2 (65.7)	15.40 (.971)	1.09 (.332)	91.3° (32.9)					
495L	10° (5.6°)	394.4 (115.6)	54.19 (3.418)	6.83 (2.083)	95.3° (35.2)	1-1/2 (1.119)	1160	9380 (4.377)	1860 (9.449)	IV
	20° (11.1°)	310.5 (91.0)	32.00 (2.019)	4.23 (1.290)	90.5° (32.5)					
	30° (16.7°)	281.7 (82.5)	19.35 (1.221)	1.67 (.509)	87.7° (30.9)					
585L	10° (5.6°)	411.7 (110.5)	28.28 (1.483)	1.62 (.442)	91.9° (33.3)	1-1/2 (1.119)	1160	10,300 (4.807)	2060 (10.465)	IV
	20° (11.1°)	377.0 (110.5)	38.85 (2.451)	3.68 (1.122)	93.7° (34.3)					
	30° (16.7°)	342.2 (100.3)	23.51 (1.483)	1.45 (.442)	90.6° (32.6)					
700L	10° (5.6°)	411.7 (110.5)	28.28 (1.483)	1.62 (.442)	91.9° (33.3)	3 (2.237)	1165	11,900 (5.553)	2380 (12.090)	IV
	20° (11.1°)	453.7 (132.9)	46.76 (2.950)	4.11 (1.254)	95.1° (35.1)					
	30° (16.7°)	411.7 (120.6)	28.28 (1.784)	1.62 (.494)	91.9° (33.3)					

**Performance based on 200°F EWT, 20°F TD, 60°F EAT. Performance at 10°F & 30°F TD is also shown.

For capacities at other conditions, use the correction multipliers in the tables on page 12.

*Speed controller option is required for reduced ratings.

HOT WATER CALCULATIONS AND CORRECTION FACTOR

EXAMPLE: –
 UNIT SIZE _____ 40
 Entering Water Temp. _____ 160°F
 Entering Air Temp. _____ 40°F
 Water Temperature Drop _____ 10°F

I. CAPACITY @ 20°F TD: A. For 200°F EWT, 60°F EAT	Read output directly from Tables 7 & 8, 22,700 BTU/HR (Ref., Std. 40, p. 8).	
B. For EWT and/or EAT above or below Standard	Multiply output from Tables 7 & 8 by factor from Table 9 (below).	22,700 x .878 = 19,931 BTU/HR.
II. CAPACITY AT OTHER TD's A. For TD's from 5 to 60°F	Multiply output obtained in IA or IB (above) by appropriate factor from Table 10 (below)	IA - 22,700 x 1.15 = 26,105 BTU/HR. –OR– IB - 19,931 x 1.15 = 22,921 BTU/HR.
III. GPM AT OTHER TD's A. For TD's from 5 to 60°F	Multiply GPM of unit for 20°F TD, from Tables 7 & 8 by appropriate factor from Table 10 (below).	2.34 x 2.30 = 5.38 GPM (Applies only to units with Std. 200°F EWT, 60°F EAT) For all others calculate using formula – $GPM = \frac{BTU}{500 \times TD}$
IV. PRESSURE LOSS AT OTHER TD's A. For TD's from 5 to 60°F	Multiply P.D. of unit for 20°F TD, from Tables 7 & 8 by appropriate factor from Table 10 (below).	.06 x 5.00 = .30 Ft. H ₂ O

**TABLE 9 — HOT WATER CONVERSION FACTORS BASED ON 200°F ENTERING WATER
60°F ENTERING AIR 20°F TEMPERATURE DROP**

ENTERING AIR TEMPERATURE °F (°C)	ENTERING WATER TEMPERATURE — 20°F WATER TEMPERATURE DROP										
	100° (38°)	120° (49°)	140° (60°)	160° (71°)	180° (82°)	200° (93°)	220° (104°)	240° (116°)	260° (127°)	280° (138°)	300° (149°)
30° (-1)	0.518	0.666	0.814	0.963	1.120	1.268	1.408	1.555	1.702	1.850	1.997
40° (4)	0.439	0.585	0.731	0.878	1.025	1.172	1.317	1.464	1.609	1.755	1.908
50° (10)	0.361	0.506	0.651	0.796	0.941	1.085	1.231	1.375	1.518	1.663	1.824
60° (16)	0.286	0.429	0.571	0.715	0.857	1.000	1.143	1.286	1.429	1.571	1.717
70° (21)	0.212	0.353	0.494	0.636	0.777	0.918	1.060	1.201	1.342	1.483	1.630
80° (27)	0.140	0.279	0.419	0.558	0.698	0.837	0.977	1.117	1.257	1.397	1.545
90° (32)	0.069	0.207	0.345	0.483	0.621	0.759	0.897	1.035	1.173	1.311	1.462
100° (38)	0	0.137	0.273	0.409	0.546	0.682	0.818	0.955	1.094	1.230	1.371

To obtain the BTU capacity for conditions other than those in the basic capacity tables, multiply the basic rating (200°F entering water, 60°F entering air,) by the proper constant from the above tables.

TABLE 10 — HOT WATER BTU, GPM AND PRESSURE LOSS FACTORS BASED ON STANDARD CONDITIONS OF 200°F ENTERING WATER 60°F ENTERING AIR & 20°F WATER DROP

USE FACTORS FROM THIS TABLE TO OBTAIN APPROXIMATE RESULTS	TEMPERATURE DROP °F (°C)								
	5 (3)	10 (6)	15 (8)	20 (11)	25 (14)	30 (17)	40 (22)	50 (28)	60 (33)
To obtain BTU for other Water Temperature Drops, multiply basic BTU rating by applicable Factor.	1.25	1.15	1.08	1.00	.94	.90	.83	.76	.72
To obtain GPM for other Water Temperature Drops, multiply basic GPM rating by applicable Factor.*	5.00	2.30	1.44	1.00	.74	.59	.40	.30	.24
To obtain Pressure Loss Feet of Water for other temperature Drops, multiply Basic loss at 20°F drop by Factor.	10.00	5.00	2.00	1.00	.60	.40	.20	.13	.07

***TABLE 11 — MINIMUM WATER FLOW — GPM**

UNIT SIZE	40	62	77	104	144	164	200	237	317	367
MIN.	.55	.55	.55	.55	.82	.82	1.10	1.10	1.10	1.10
GPM (L/s)	(.035)	(.035)	(.035)	(.035)	(.052)	(.052)	(.069)	(.069)	(.069)	(.069)

***TABLE 12 — HEATING CAPACITY FACTORS FOR VARIOUS RATES OF WATER FLOW**

% of Rated Water Flow	25%	50%	75%	100%	125%	150%	175%
Btu/Hr Heating Capacity	.80	.89	.96	1.00	1.04	1.07	1.10

TECHNICAL DATA

The performance data listed in Tables 3, 4, 7 and 8 include sound ratings. The ratings provide a guide in determining the acceptable degree of loudness in particular occupancy situations.

Certain general rules apply to specific selection of unit heaters with regard to degree of quietness (or loudness);

- The greater the fan diameter, the higher the sound level.
- The higher the motor RPM, the higher the sound level. Note that on most units the lower the speed mode results in lowering the sound rating one increment.
- Selecting a larger number of smaller units generally results in lower overall noise levels than fewer large units.

All vertical steam and hot water unit heater motors, whether fan guard or shelf-mounted, are isolated from the mechanical mount by resilient isolators. This mounting along with balanced fan blades and excellent overall construction integrity, assures you the utmost in quiet operation.

The following table outlines sound ratings for various applications. The lower the number, the quieter the unit and the lower the sound requirement.

CATEGORY OF AREA	SOUND RATING
Apartment, assembly hall, classrooms churches, courtrooms, executive offices, hospitals, libraries, museums, theatres.	I
Dining rooms, general offices, recreation areas, small retail stores.	II
Restaurants, banks, cafeterias, depart- ment stores, public buildings, service stations.	III
Gymnasiums, health clubs, laundromats, supermarkets.	IV
Garages, small machine shops, light manufacturing.	V
Factories, foundries, steel mills.	III - VII*

*Depending on specific use in these facilities, size of operation, etc.

CORRECTIONS WHEN USING GLYCOL SOLUTION IN SYSTEM

	Propylene Glycol		Propylene Glycol														
1. Heat transfer @180°F with no increase in flow rate	.97*	7. Freezing Point 55% by volume	-														
20% solution		50%	-28°F														
50% solution	.90*	40%	-13°F														
2. G.P.M. Req'd. @180°F, 20° Δ t (no correction to pump curve)	1.10%*	30%	+ 4°F														
3. Pump Head Req'd. @180°F w/increase in G.P.M.	1.23%*	20%	+17°F														
4. Specify gravity (water = 1.0)	1.045-1.055*	*Compared to water.															
5. Pounds/Gallons @60°F (water = 8.3453 Pound/Gallon)	8.77	<table style="width: 100%; border-collapse: collapse; margin: 0 auto;"> <thead> <tr> <th colspan="2" style="text-align: center; border-top: 1px solid black; border-bottom: 1px solid black;">Approximate factors at varying altitudes</th> </tr> <tr> <th style="text-align: center; border-bottom: 1px solid black;">Altitude</th> <th style="text-align: center; border-bottom: 1px solid black;">Factor</th> </tr> </thead> <tbody> <tr> <td style="text-align: center;">Sea level - 1000 ft.</td> <td style="text-align: center;">1.00</td> </tr> <tr> <td style="text-align: center;">1000 ft. - 3000 ft.</td> <td style="text-align: center;">.958</td> </tr> <tr> <td style="text-align: center;">3000 ft. - 5000 ft.</td> <td style="text-align: center;">.929</td> </tr> <tr> <td style="text-align: center;">5000 ft. - 7000 ft.</td> <td style="text-align: center;">.900</td> </tr> <tr> <td style="text-align: center;">7000 ft. - 10000 ft.</td> <td style="text-align: center;">.871</td> </tr> </tbody> </table>		Approximate factors at varying altitudes		Altitude	Factor	Sea level - 1000 ft.	1.00	1000 ft. - 3000 ft.	.958	3000 ft. - 5000 ft.	.929	5000 ft. - 7000 ft.	.900	7000 ft. - 10000 ft.	.871
Approximate factors at varying altitudes																	
Altitude	Factor																
Sea level - 1000 ft.	1.00																
1000 ft. - 3000 ft.	.958																
3000 ft. - 5000 ft.	.929																
5000 ft. - 7000 ft.	.900																
7000 ft. - 10000 ft.	.871																
6. pH @ 50% by volume	9.5																

MOTOR DATA

NOTE 1: All motors are constant speed and operate at top speed as indicated in motor data. Models through 1/8 H.P. can be run at reduced speed with addition of optional variable speed switch. This switch is factory-calibrated for low and high speed ratings, with intermediate speeds infinitely controllable. Models 164 through 700 operate at constant speed as indicated in motor data.

NOTE 2: Stated draw is Full Load (FLA). AMP draw varies by motor manufacturer ± .2 AMPS. Verify FLA on motor data plate.

CAUTION: Select appropriate AMP MCA, and MOP for the multiple voltage motors. For example, the AMP, MCA, and MOP for Model 40 with a 230 volt Totally Enclosed motor is 1.1, 1.4, and 2.5 respectively.

Table 13 - Standard (Totally Enclosed) Motor Type [MT=1]

Unit Size	AMP	MCA	MOP	HP	RPM
115/1/60† [SV=1]					
40	1.23**	1.6	2.8	1/40*	1550
62	2.1**	2.6	4.7	1/20*	1550
77					
104	1.2**	1.5	2.7	1/8*	1070
125	2.3**	2.9	5.2	1/6	1100
144					
164					
200	3.6**	4.5	8.1	1/4	1100
237	3.6**	4.5	8.1	1/4	1100
285	5.4**	6.8	12.2	1/2	1100

208-230/460/3/60 [SV=4, 5 or 6]

40	0.98-1.1/0.55	1.2-1.4/0.7	2.2-2.5/1.2	1/6	1140
62	0.98-1.1/0.55	1.2-1.4/0.7	2.2-2.5/1.2	1/6	1140
77					
104	0.98-1.1/0.55	1.2-1.4/0.7	2.2-2.5/1.2	1/6	1140
125	0.98-1.1/0.55	1.2-1.4/0.7	2.2-2.5/1.2	1/6	1140
144					
164					
200	1.2-1.4/0.7	1.5-1.8/0.9	2.7-3.2/1.6	1/4	1140
237	1.2-1.4/0.7	1.5-1.8/0.9	2.7-3.2/1.6	1/4	1140
285	1.8-2.0/1.0	2.3-2.5/1.3	4.1-4.5/2.3	1/2	1140
317	3.1-3.2/1.6	3.9-4.0/2.0	7.0-7.2/3.6	3/4	1140
367					
495	5.0-4.4/2.2	6.3-5.5/2.8	11.9-11.3/5.6	1-1/2	1160
585					
700	9.6-8.2/4.1	12.0-10.3/5.1	22.3-22.1/11.0	3	1165

575/3/60 [SV=7]

40	0.6	0.8	1.4	1/3	1140
62					
77					
104					
125					
144					
164					
200					
237	0.8	1.0	1.8	1/2	1140
285					
317	1.3	1.6	2.9	3/4	1140
367					
495	2.0	2.5	4.5	1-1/2	1160
585					
700	3.8	4.7	8.4	3	1165

Table 14 - Explosion Proof with Thermal Overload Motor Type [MT=2]

Unit Size	AMP	MCA	MOP	HP	RPM
115/1/60† [SV=1]					
40	3.8	4.8	8.6	1/6	1140
62	3.8	4.8	8.6	1/6	1140
77					
104	3.8	4.8	8.6	1/6	1140
125	3.8	4.8	8.6	1/6	1140
144					
164					
200	4.4	5.5	9.9	1/4	1140
237	4.4	5.5	9.9	1/4	1140
285	7.8	9.8	17.6	1/2	1140

208-230/460/3/60 [SV=4, 5 or 6]

40	1.0-1.0/0.5	1.3-1.3/0.6	2.3-2.3/1.1	1/6	1140
62	1.0-1.0/0.5	1.3-1.3/0.6	2.3-2.3/1.1	1/6	1140
77					
104	1.0-1.0/0.5	1.3-1.3/0.6	2.3-2.3/1.1	1/6	1140
125	1.0-1.0/0.5	1.3-1.3/0.6	2.3-2.3/1.1	1/6	1140
144					
164					
200	1.1-1.1/0.55	1.4-1.4/0.7	2.5-2.5/1.2	1/4	1140
237	1.1-1.1/0.55	1.4-1.4/0.7	2.5-2.5/1.2	1/4	1140
285	1.9/0.95***	2.4/1.2	4.3/2.1	1/2	1140
317	3.1-3.2/1.6	3.9-4.0/2.0	7.0-7.2/3.6	3/4	1145
367					
495	5.0/2.5***	6.5/3.3	11.7/5.9	1-1/2	1150
585					
700	10.0/5.0***	12.5/6.3	22.5/11.3	3	1150

*Optional variable speed switch is available.

** These motors have automatic thermal overload protection or impedance protection.

*** These motors are 230/460 volts only.

† Models 317 through 700 are not available for either Totally Enclosed or Explosion Proof with Overload 115/1/60 motor types.

INSTALLATION

It is assumed that the design engineer has selected, sized, and located in the area to be heated by the design engineer. However, the information given here may be of additional help to the installer.

Vertical unit heaters should be located to give spot heating or a circulatory distribution, preferably near the outer perimeter of the building. The units should be spaced to properly blanket the areas with warm air. Place the units at points of greatest heat loss. Blanket outside doorway and provide ample coverage of window areas. Keep units away from obstructions that will impede the full and natural air delivery of the units.

Install unit heaters to meet ETL and OSHA requirements; Vertical Unit Heaters mounted lower than 2.4 meters (8 feet) from the floor must be equipped with an OSHA fan guard. Weldnuts are provided at the top of all units for suspension purposes. The unit should be suspended from connections provided in the unit by means of rods. The rods should then be attached to solid supports of the building.

Units must hang level vertically and horizontally.

Provide sufficient clearance around units for maintenance purposes. This includes at least 7 inches above all Vertical Unit Heaters even though the motor is removable through the bottom. To provide efficient airflow to the unit, maintain a clearance of 2 feet (0.61m) around all sides of the unit.

Isolators are not required but may be desirable for some applications. Refer to Table 15 for Unit Weights.

Table 15 – Unit Weights-Lbs

VERTICAL UNIT HEATERS	
Unit	Approx. Ship Weight (Lbs.)
40	32
62	40
77	43
104	63
125	64
144	80
164	80
200	86
237	134
285	139
317	139
367	146
495	294
585	307
700	366

▲ WARNING Make certain that the lifting methods used to lift the heater and the method of suspension used in the field installation of the heater are capable of uniformly supporting the weight of the heater at all times. Failure to heed this warning may result in property damage or personal injury!

▲ WARNING Make certain that the structure to which the heater is mounted is capable of supporting its weight. Under no circumstances must the piping or the electrical conduit be used to support the heater; or should any other objects (i.e. ladder, person) lean against the heater or the electrical conduit for support.

▲ CAUTION Unit heaters must be hung level from side to side and from front to back. Failure to do so will result in poor performance and or premature failure of the unit.

▲ WARNING Ensure that all hardware used in the suspension of each unit heater is more than adequate for the job. Failure to do so may result in extensive property damage, severe personal injury or death.

EXAMPLE

Table 18 lists maximum mounting height and floor spread data of warm air coverage at floor level with louver cone diffusers. Correction factors for various water temp. and PSI of steam are in Table 19.

An approximation of the floor spread when operating on other than 2 lb. Steam or 219 degree may be obtained by ratioing the new floor spread and the maximum mounting height to that at 2 lb. steam or 219 degree hot water.

Following is an example:

Determine the floor spread and the maximum mounting height of a std. model 77 unit heater with a cone diffuser set at 90 degrees, operating on 280 degree hot water.

From Table 18, maximum mounting height of a model 77 at 219 degree hot water is 18.5 ft. with floor coverage of 14.0 ft. diameter. The maximum mounting height correction factor at 280 degree hot water is 0.80.

$$18.5 \text{ ft.} \times 0.80 = 14.8 \text{ ft.}$$

Maximum mounting height of a model 77 using 280 degree hot water.

“X” = floor spread of model 77 using 280 degree hot water.

$$X = 14.8 \times 14.0 / 18.5$$

$$X = 207.2 / 18.5$$

$$X = 11.2 \text{ ft.}$$

Table 16 - Maximum Mounting Height in Feet with and without Louver Cone Diffuser

Unit Size	Steam Pressure (PSI)					Unit Size	Steam Pressure (PSI)				
	2 (13.8)	5 (34.5)	10 (68.9)	50 (344.7)	75 (517.1)		2 (13.8)	5 (34.5)	10 (68.9)	50 (344.7)	75 (517.1)
40	10.5 (3.2)	10.0 (3.0)	10.0 (3.0)	9.0 (2.7)	8.0 (2.4)	77L	18.0 (5.5)	17.5 (5.3)	17.5 (5.3)	15.0 (4.6)	14.0 (4.3)
	12.5 (3.8)	12.0 (3.7)	12.0 (3.7)	11.0 (3.4)	10.0 (3.0)		22.0 (6.7)	21.0 (6.4)	21.0 (6.4)	19.0 (5.8)	18.0 (5.5)
40*	7.5 (2.3)	7.5 (2.3)	7.5 (2.3)	7.5 (2.3)	7.5 (2.3)	77L*	13.0 (4.0)	12.5 (3.8)	12.0 (3.7)	11.0 (3.4)	10.5 (3.2)
	9.0 (2.7)	8.5 (2.6)	8.5 (2.6)	7.5 (2.3)	7.5 (2.3)		17.0 (5.2)	16.5 (5.0)	16.0 (4.9)	14.0 (4.3)	13.5 (4.1)
40L	12.5 (3.8)	12.0 (3.7)	12.0 (3.7)	10.5 (3.2)	9.5 (2.9)	104	14.0 (4.3)	13.5 (4.1)	13.0 (4.0)	11.5 (3.5)	11.0 (3.4)
	14.5 (4.4)	14.0 (4.3)	13.5 (4.1)	12.0 (3.7)	11.5 (3.5)		17.0 (5.2)	16.5 (5.0)	16.0 (4.9)	14.0 (4.3)	13.5 (4.1)
40L*	9.0 (2.7)	8.5 (2.6)	8.5 (2.6)	7.5 (2.3)	7.5 (2.3)	104*	11.0 (3.4)	10.5 (3.2)	10.5 (3.2)	9.5 (2.9)	9.0 (2.7)
	10.5 (3.2)	10.0 (3.0)	10.0 (3.0)	9.0 (2.7)	8.5 (2.6)		13.5 (4.1)	13.0 (4.0)	13.0 (4.0)	12.0 (3.7)	11.5 (3.5)
62	12.0 (3.7)	11.5 (3.5)	11.5 (3.5)	10.0 (3.0)	9.5 (2.9)	104L	17.5 (5.3)	17.0 (5.2)	16.5 (5.0)	15.0 (4.6)	14.5 (4.4)
	14.5 (4.4)	14.0 (4.3)	14.0 (4.3)	12.0 (3.7)	11.5 (3.5)		21.5 (6.6)	21.0 (6.4)	20.5 (6.2)	18.5 (5.6)	17.5 (5.3)
62*	9.5 (2.9)	9.0 (2.7)	9.0 (2.7)	8.0 (2.4)	8.0 (2.4)	104L*	15.0 (4.6)	14.5 (4.4)	14.5 (4.4)	13.0 (4.0)	12.5 (3.8)
	11.5 (3.5)	11.0 (3.4)	11.0 (3.4)	9.5 (2.9)	9.0 (2.7)		18.5 (5.6)	18.0 (5.5)	18.0 (5.5)	16.0 (4.9)	15.0 (4.6)
62L	15.0 (4.6)	14.5 (4.4)	14.5 (4.4)	12.5 (3.8)	12.0 (3.7)	125	16.0 (4.9)	15.5 (4.7)	15.5 (4.7)	14.0 (4.3)	13.5 (4.1)
	19.0 (5.8)	18.5 (5.6)	18.5 (5.6)	16.5 (5.0)	16.0 (4.9)		19.5 (5.9)	19.0 (5.8)	18.5 (5.6)	17.0 (5.2)	16.0 (4.9)
62L*	11.5 (3.5)	11.0 (3.4)	11.0 (3.4)	9.5 (2.9)	9.0 (2.7)	125L	21.0 (6.4)	20.5 (6.2)	20.0 (6.1)	17.5 (5.3)	17.0 (5.2)
	14.0 (4.3)	13.5 (4.1)	13.5 (4.1)	12.0 (3.7)	11.5 (3.5)		26.0 (7.9)	25.5 (7.8)	25.0 (7.6)	22.5 (6.9)	21.5 (6.6)
77	15.0 (4.6)	14.5 (4.4)	14.0 (4.3)	12.0 (3.7)	11.5 (3.5)	144	15.5 (4.7)	15.0 (4.6)	14.5 (4.4)	13.0 (4.0)	12.0 (3.7)
	18.5 (5.6)	18.0 (5.5)	17.5 (5.3)	15.5 (4.7)	15.0 (4.6)		19.0 (5.8)	18.5 (5.6)	18.0 (5.5)	16.0 (4.9)	15.5 (4.7)
77*	11.0 (3.4)	10.5 (3.2)	10.5 (3.2)	9.0 (2.7)	8.5 (2.6)	144L	18.0 (5.5)	17.5 (5.3)	17.5 (5.3)	15.0 (4.6)	14.0 (4.3)
	13.5 (4.1)	13.0 (4.0)	13.0 (4.0)	11.5 (3.5)	11.0 (3.4)		22.5 (6.9)	22.0 (6.7)	21.5 (6.6)	18.5 (5.6)	18.0 (5.5)

NOTES:

* = Low Speed

L = Low output model with all air ports open

Figures in bold face show maximum mounting height with louver cone diffusers set vertically.

Above table based on 60°F entering air temperature. In providing for the use of diffusers, it must be remembered that adjustment of a LCD to deflect air toward horizontal immediately lowers the mounting height limit.

Table 16 - Maximum Mounting Height in Feet with and without Louver Cone Diffuser

Unit Size	Steam Pressure (PSI)					Unit Size	Steam Pressure (PSI)				
	2 (13.8)	5 (34.5)	10 (68.9)	50 (344.7)	75 (517.1)		2 (13.8)	5 (34.5)	10 (68.9)	50 (344.7)	75 (517.1)
164	18.0 (5.5)	17.5 (5.3)	17.0 (5.2)	14.5 (4.4)	14.0 (4.3)	317L	29.0 (8.8)	28.5 (8.7)	28.0 (8.5)	25.0 (7.6)	24.0 (7.3)
	22.5 (6.9)	22.0 (6.7)	21.5 (6.6)	19.0 (5.8)	18.0 (5.5)		36.0 (11.0)	35.0 (10.7)	34.0 (10.4)	30.0 (9.1)	29.0 (8.8)
164L	22.0 (6.7)	21.5 (6.6)	21.0 (6.4)	18.5 (5.6)	17.5 (5.3)	367	28.5 (8.7)	28.0 (8.5)	27.5 (8.4)	24.0 (7.3)	23.0 (7.0)
	27.5 (8.4)	27.0 (8.2)	26.5 (8.1)	23.5 (7.2)	22.5 (6.9)		35.5 (10.8)	35.0 (10.7)	34.0 (10.4)	30.0 (9.1)	29.0 (8.8)
200	22.0 (6.7)	21.5 (6.6)	21.0 (6.4)	18.5 (5.6)	17.5 (5.3)	367L	32.5 (9.9)	31.5 (9.6)	30.5 (9.3)	27.5 (8.4)	26.5 (8.1)
	27.5 (8.4)	27.0 (8.2)	26.5 (8.1)	24.0 (7.3)	23.0 (7.0)		41.0 (12.5)	40.0 (12.2)	39.0 (11.9)	35.0 (10.7)	33.5 (10.2)
200L	25.5 (7.8)	25.0 (7.6)	24.5 (7.5)	22.0 (6.7)	21.0 (6.4)	495	29.5 (9.0)	29.0 (8.8)	28.5 (8.7)	25.0 (7.6)	24.0 (7.3)
	31.5 (9.6)	31.0 (9.4)	30.5 (9.3)	27.0 (8.2)	26.0 (7.9)		36.5 (11.1)	36.0 (11.0)	35.5 (10.8)	32.0 (9.8)	30.5 (9.3)
237	20.0 (6.1)	19.5 (5.9)	19.0 (5.8)	17.0 (5.2)	16.0 (4.9)	495L	35.0 (10.7)	34.0 (10.4)	33.0 (10.1)	29.0 (8.8)	28.0 (8.5)
	25.0 (7.6)	24.0 (7.3)	23.5 (7.2)	20.5 (6.2)	19.5 (5.9)		43.5 (13.3)	42.5 (13.0)	41.5 (12.6)	35.0 (10.7)	34.0 (10.4)
237L	24.0 (7.3)	23.5 (7.2)	23.0 (7.0)	20.0 (6.1)	19.0 (5.8)	585	34.0 (10.4)	33.0 (10.1)	32.0 (9.8)	28.0 (8.5)	27.0 (8.2)
	29.5 (9.0)	28.5 (8.7)	28.0 (8.5)	24.5 (7.5)	23.5 (7.2)		42.5 (13.0)	41.5 (12.6)	40.5 (12.3)	36.0 (11.0)	34.5 (10.5)
285	21.0 (6.4)	20.5 (6.2)	20.0 (6.1)	17.5 (5.3)	17.0 (5.2)	585L	37.0 (11.3)	36.0 (11.0)	35.0 (10.7)	31.0 (9.4)	30.0 (9.1)
	26.0 (7.9)	25.5 (7.8)	25.0 (7.6)	22.0 (6.7)	21.0 (6.4)		46.5 (14.2)	45.5 (13.9)	44.5 (13.6)	39.0 (11.9)	37.0 (11.3)
285L	25.5 (7.8)	25.0 (7.6)	24.5 (7.5)	21.0 (6.4)	20.0 (6.1)	700	38.5 (11.7)	37.5 (11.4)	36.5 (11.1)	32.0 (9.8)	30.5 (9.3)
	32.0 (9.8)	31.0 (9.4)	30.0 (9.1)	26.0 (7.9)	25.0 (7.6)		48.0 (14.6)	47.0 (14.3)	46.0 (14.0)	40.0 (12.2)	39.0 (11.9)
317	24.0 (7.3)	23.0 (7.0)	22.0 (6.7)	20.0 (6.1)	19.0 (5.8)	700L	42.5 (13.0)	41.5 (12.6)	40.5 (12.3)	35.0 (10.7)	33.5 (10.2)
	30.0 (9.1)	29.0 (8.8)	28.0 (8.5)	25.0 (7.6)	24.0 (7.3)		53.0 (16.2)	52.0 (15.8)	51.0 (15.5)	44.0 (13.4)	42.0 (12.8)

NOTES:

* = Low Speed

L = Low output model with all air ports open

Figures in bold face show maximum mounting height with louver cone diffusers set vertically.

Above table based on 60°F entering air temperature. In providing for the use of diffusers, it must be remembered that adjustment of a LCD to deflect air toward horizontal immediately lowers the mounting height limit.

Table 17 - Maximum Spread

Unit Size	40	62	77	104	125	144	164	200	237	285	317	367	495	585	700
Spread	15	17	20	24	26	27	28	32	35	37	45	50	54	57	60
ft (m)	(4.6)	(5.2)	(6.1)	(7.3)	(7.9)	(8.2)	(8.5)	(9.8)	(10.7)	(11.3)	(13.7)	(15.2)	(16.5)	(17.4)	(18.3)

Note: The "spread" is the diameter of the comfort zone at floor level. The above table represents the spread for standard units without a lower cone diffuser and mounted at its maximum height at 2 PSI (13.8 kPa) steam pressure and 60°F (16°C) entering air. (See Table 16 for maximum mounting heights.)

Figure 5

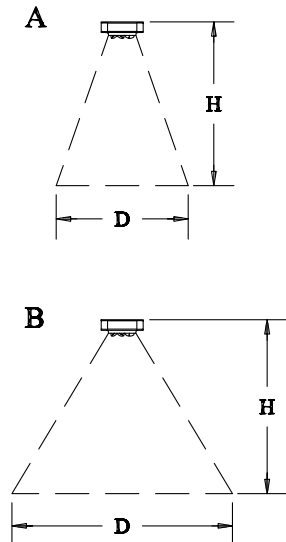

See Example

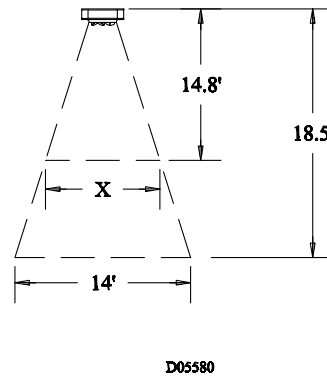

Table 18 - Maximum Mounting Height and Diameter at Floor (Based on 60°F EAT and 219°F EWT or 2 PSI steam)

Unit Size	Diffuser Cone 90° See Figure 5A				Diffuser Cone 45° See Figure 5B			
	Standard		Low Output		Standard		Low Output	
	H ft (m)	D ft (m)	H ft (m)	D ft (m)	H ft (m)	D ft (m)	H ft (m)	D ft (m)
40	12.5 (3.8)	11.0 (3.4)	14.5 (4.4)	16.0 (4.9)	9.0 (2.7)	20.0 (6.1)	11.0 (3.4)	25.0 (7.6)
62	14.5 (4.4)	12.0 (3.7)	19.0 (5.8)	19.0 (5.8)	10.0 (3.0)	24.0 (7.3)	12.0 (3.7)	29.0 (8.8)
77	18.5 (5.6)	14.0 (4.3)	22.0 (6.7)	23.0 (7.0)	12.5 (3.8)	26.0 (7.9)	15.0 (4.6)	31.0 (9.4)
104	17.0 (5.2)	18.0 (5.5)	21.5 (6.6)	26.0 (7.9)	11.0 (3.4)	31.0 (9.4)	14.0 (4.3)	35.0 (10.7)
125	19.5 (5.9)	19.0 (5.8)	26.0 (7.9)	29.0 (8.8)	13.0 (4.0)	33.0 (10.1)	16.0 (4.9)	38.0 (11.6)
144	19.0 (5.8)	20.0 (6.1)	22.5 (6.9)	30.0 (9.1)	12.0 (3.7)	39.0 (11.9)	15.5 (4.7)	44.0 (13.4)
164	22.5 (6.9)	21.0 (6.4)	27.5 (8.4)	31.0 (9.4)	13.0 (4.0)	42.0 (12.8)	18.0 (5.5)	48.0 (14.6)
200	27.5 (8.4)	25.0 (7.6)	31.5 (9.6)	35.0 (10.7)	14.0 (4.3)	45.0 (13.7)	21.0 (6.4)	53.0 (16.2)
237	25.0 (7.6)	27.0 (8.2)	29.5 (9.0)	38.0 (11.6)	13.0 (4.0)	47.0 (14.3)	19.0 (5.8)	55.0 (16.8)
285	26.0 (7.9)	29.0 (8.8)	32.0 (9.8)	40.0 (12.2)	15.0 (4.6)	50.0 (15.2)	21.0 (6.4)	60.0 (18.3)
317	30.0 (9.1)	34.0 (10.4)	36.0 (11.0)	47.0 (14.3)	18.0 (5.5)	55.0 (16.8)	24.0 (7.3)	66.0 (20.1)
367	35.5 (10.8)	39.0 (11.9)	41.0 (12.5)	52.0 (15.8)	20.0 (6.1)	59.0 (18.0)	28.0 (8.5)	71.0 (21.6)
495	36.5 (11.1)	42.0 (12.8)	43.5 (13.3)	57.0 (17.4)	24.0 (7.3)	65.0 (19.8)	30.0 (9.1)	76.0 (23.2)
585	42.5 (13.0)	45.0 (13.7)	46.5 (14.2)	60.0 (18.3)	26.0 (7.9)	70.0 (21.3)	34.0 (10.4)	78.0 (23.8)
700	48.0 (14.6)	46.0 (14.0)	53.0 (16.2)	63.0 (19.2)	28.0 (8.5)	75.0 (22.9)	38.0 (11.6)	87.0 (26.5)

Table 19 - Mounting Height Correction Factors

Water Temperature	°F	150	160	170	180	190	200
	(°C)	(66)	(71)	(77)	(82)	(88)	(93)
Steam Pressure	PSI	—	—	—	—	—	—
	(kPa)	—	—	—	—	—	—
Correction Factor		1.32	1.27	1.23	1.18	1.14	1.09

Water Temperature	°F	210	219	227	239	250	259
	(°C)	(99)	(104)	(108)	(115)	(121)	(126)
Steam Pressure	PSI	—	2	5	10	15	20
	(kPa)	—	(13.8)	(34.5)	(68.9)	(103.4)	(137.9)
Correction Factor		1.05	1.00	0.97	0.94	0.89	0.86

Water Temperature	°F	267	280	287	298	307	320
	(°C)	(131)	(138)	(142)	(148)	(153)	(160)
Steam Pressure	PSI	25	35	40	50	60	75
	(kPa)	(172.4)	(241.3)	(275.8)	(344.7)	(413.6)	(517.1)
Correction Factor		0.83	0.80	0.76	0.73	0.70	0.69

To meet OSHA requirements, units mounted lower than 8 feet from the floor must be equipped with an OSHA fan guard.

PIPING

To provide proper coil operation, follow all piping recommendations listed in this manual.

Threaded pipe headers are provided on all Vertical Units for piping connections. See Figure 5. Connections are given in Figures 3 and 4 and Tables 1 and 2.

Follow standard practices and codes when installing the piping. Provide swing joints for expansion purposes, unions and shut-off valves for servicing purposes and as illustrated in Figures 6 through 9, valves and traps for control purposes. Use 45 degree angle run-offs from all supply and return mains.

Dirt pockets should be the same pipe size as the return tapping of the unit heater. Also, pipe size in the branch-off should be the same size as the tapping in the traps. Beyond the trap, the return lateral pipe should be increased one size up to the return main.

Properly support all piping to unit! Do not allow piping to place a strain on the coil or unit. Noise or coil failure may occur.

It is assumed that the type of system to be used has been selected by design engineer. The sketches shown are for different type of steam systems or hot water systems. For sizing of piping, traps, filter, etc., consult ASHRAE guides of the manufacturer's literature on these products.

Figure 6 – Forced Hot Water

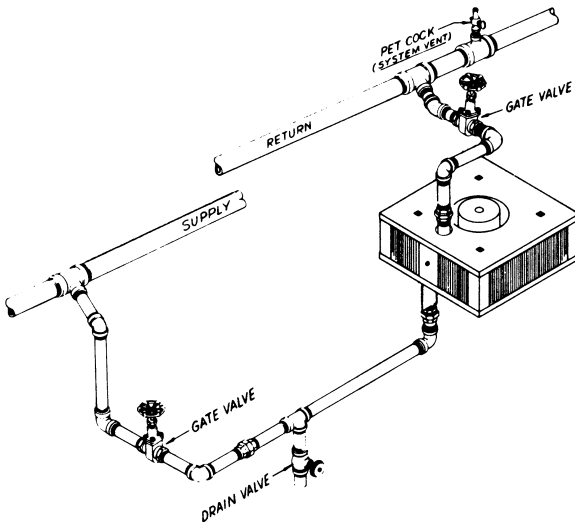

Figure 7 – High Pressure Steam

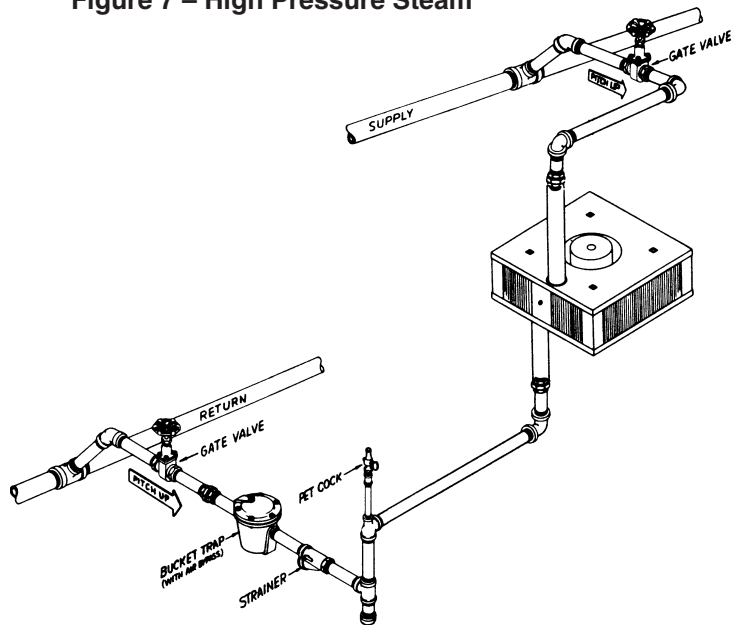

Figure 8 – Low Pressure Steam (Gravity)

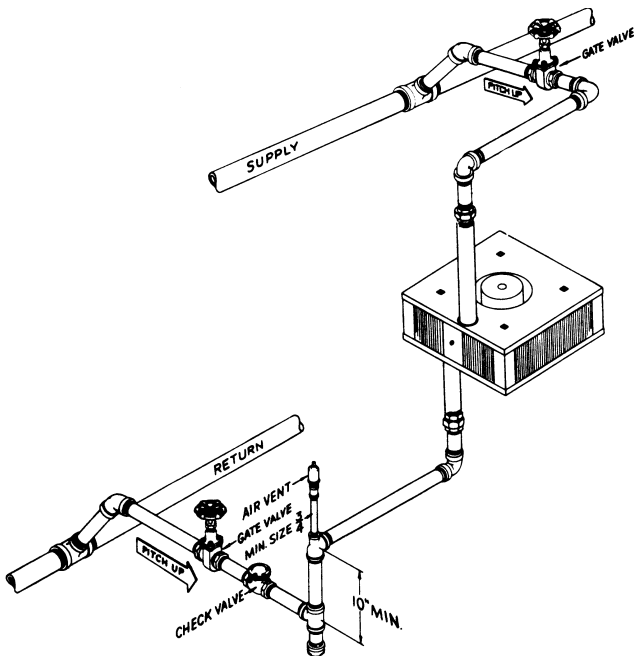
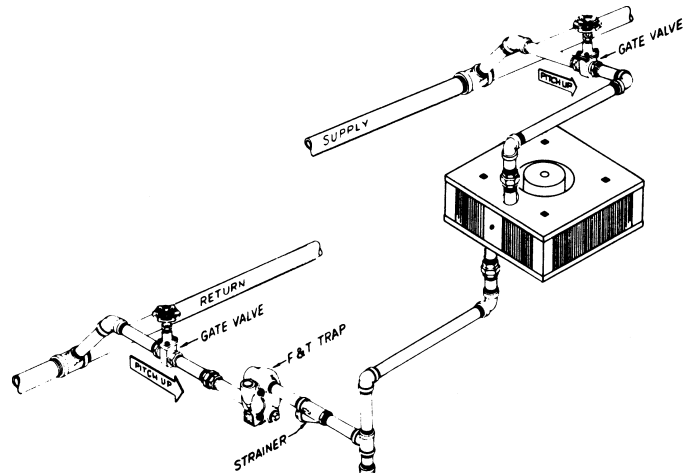

Figure 9 – Low Pressure Vapor or Vacuum



ELECTRICAL CONNECTIONS

	<p>▲ WARNING</p> <p>HAZARDOUS VOLTAGE! disconnect ALL ELECTRIC POWER INCLUDING REMOTE DISCONNECTS BEFORE SERVICING. Failure to disconnect power before servicing can cause severe personal injury or death.</p>
---	---

Standard units are shipped for use on 115 volt, 60 hertz single phase electric power. The motor nameplate and electrical rating on the transformer should be checked before energizing the unit heater electrical system. All external wiring must conform to the latest edition of the National Electric Code, ANSI/NFPA No. 70 and applicable current local codes; in Canada, to the Canadian Electrical Code, Part 1 CSA Standard C22.1.

▲ CAUTION Do not use any tools (i.e. screwdriver, pliers, etc.) across the terminals to check for power. Use a voltmeter.

It is recommended that the electrical power supply to each unit heater be provided by a separate, fused and permanently live electrical circuit. A disconnect switch of suitable electrical rating for each unit heater should be located as close to the controls as possible. Each unit heater must be electrically grounded in accordance with the latest edition of the National Electric Code, ANSI/NFPA No. 70 or and applicable current local codes; In Canada to the Canadian Electrical Code, Part 1, CSA C22.1. Sample wiring connections are depicted in Figures 14 through 24.

OPERATION

Most basic unit heater systems are controlled by a room thermostat. Locate thermostat on inner wall or column so that optimum control could be obtained for that area. Set thermostat for desired temperature.

On steam systems a low limit may be used to prevent fan from blowing cold air unless the heater has steam passing through the coil.

Small hot water systems could have the circulating pump controlled directly by the room thermostat. On large systems, zone valves could be used to control the individual unit heater where constant water circulation is used on the main system.

THERMOSTAT WIRING AND LOCATION

NOTICE: The thermostat must be mounted on a vertical vibration-free surface free from air currents and in accordance with the furnished instructions.

Mount the thermostat approximately 5 feet (1.5 m) above the floor in an area where it will be exposed to a free circulation of average temperature air. Always refer to the thermostat instructions as well as our unit wiring diagram and wire accordingly. Avoid mounting the thermostat in the following locations:

1. Cold areas - Outside walls or areas where drafts may affect the operation of the control.
2. Hot areas - Areas where the sun's rays, radiation, or warm air currents may affect control operation.
3. Dead areas - Areas where air cannot circulate freely, such as behind doors or in corners.

NOTICE: For all wiring connections, refer to the wiring diagram on the motor nameplate (refer to pages 21 and 22). Should any original wire supplied with the heater have to be replaced, it must be replaced with wiring material having a temperature rating of at least 105° C.

MOTORS

The standard 115/1/60 motors provided on Vertical Unit Heaters are totally enclosed, Class "B" insulated and have built-in thermal overload protection.

Vertical Units 40 through 72 use sleeve type bearings. Vertical Units 125 through 285 use permanent split capacitor motors with ball bearings.

All sleeve bearing motors have oil holes to allow lubrication. Ball bearing motors are permanently lubricated although some three phase or special motors have removable plugs which will allow field installation of grease fittings.

The standard 40 through 104 motors can be converted to variable speed operation with the addition of the solid state speed control.

See Figures 10 through 24 for typical wiring diagrams.

Figure 10 - Fan Motor Connections
 Low Voltage with
 Protector Select
 Rotation (CCW shown)
 (Marathon)

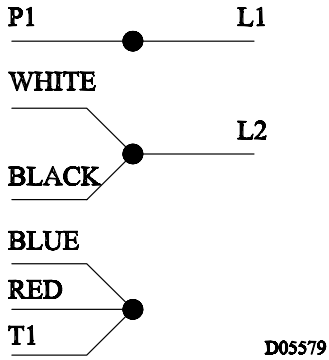

For CW Rotation Interchange
 (Red and black lead)

Figure 11 - Fan Motor Connections
 Low Voltage CCW
 Internal (Marathon)

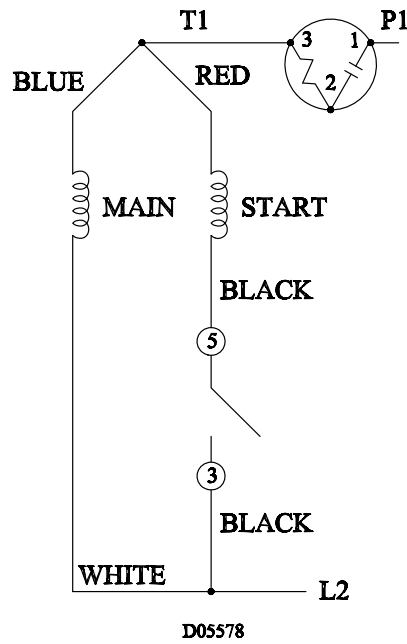

Figure 12 - Fan Motor Connections
 115/1/60 Constant
 Speed, Two Lead (GE,
 Marathon, Universal)

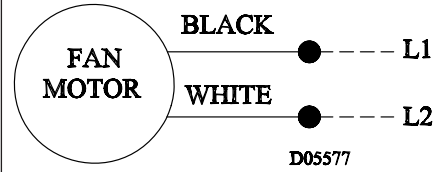
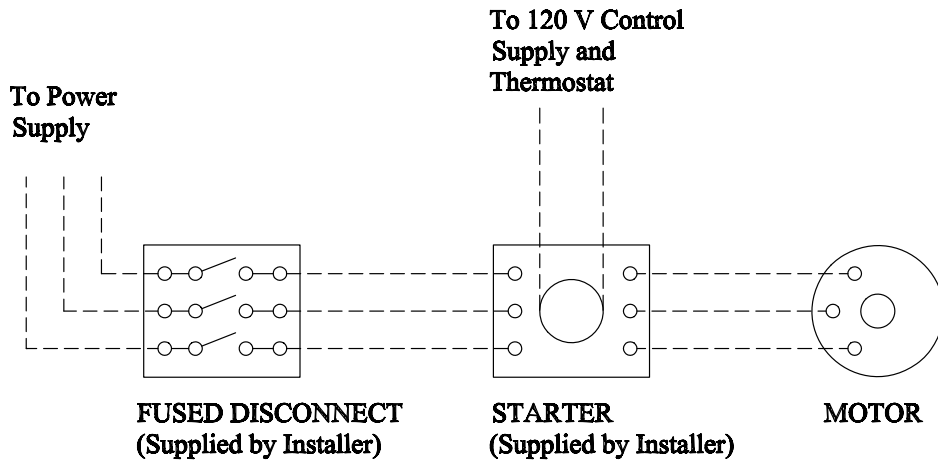

Figure 13 - Fan Motor Connections 3 Phase Wiring



D05576

WIRING INSTALLATION

Figure 14 - MANUAL CONTROL WITH SINGLE PHASE MOTOR

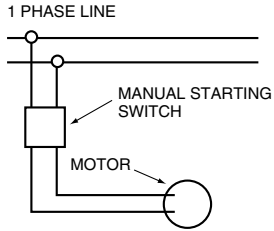

Figure 15 - THERMOSTATIC CONTROL WITH MANUAL STARTER

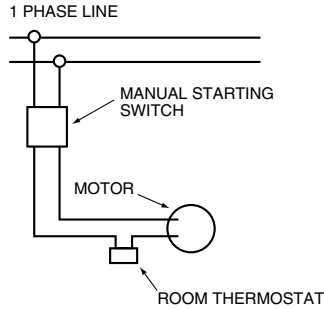

Figure 16 - THERMOSTATIC CONTROL WITH REVERSE ACTING CONTROLLER AND MANUAL STARTER

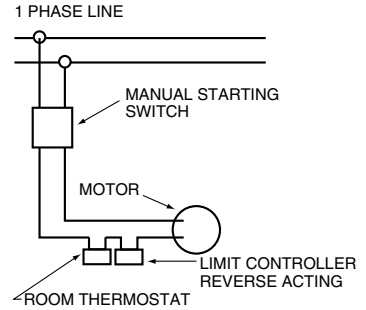

Figure 17 - THERMOSTATIC CONTROL USING MAGNETIC STARTER OPERATING SEVERAL UNITS

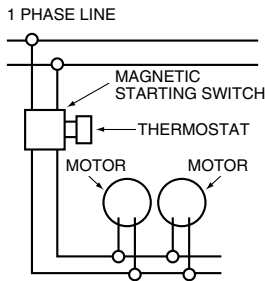

Figure 18 - THREE POSITION SELECTOR SWITCH USED FOR EITHER MANUAL OR THERMOSTATIC CONTROL

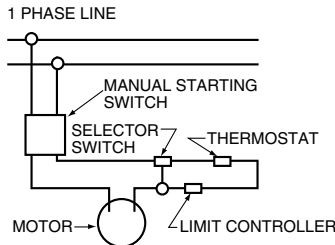

Figure 19 - THREE POSITION SELECTOR SWITCH BUILT INTO MAGNETIC STARTER FOR MANUAL OR THERMOSTATIC CONTROL

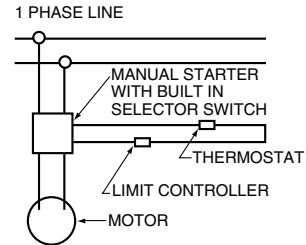

Figure 20 - SPEED CONTROLLER WITH MANUAL STARTING SWITCH

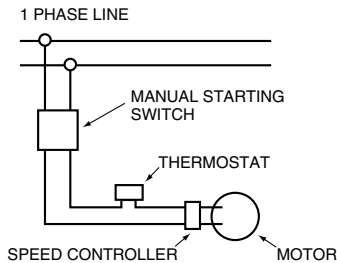

Figure 21 - SPEED CONTROLLERS WITH MAGNETIC STARTING SWITCH FOR OPERATING SEVERAL UNITS

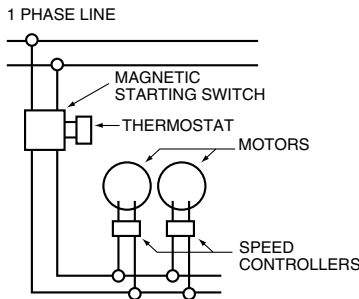

Figure 22 - MANUAL CONTROL WITH THREE PHASE MOTOR

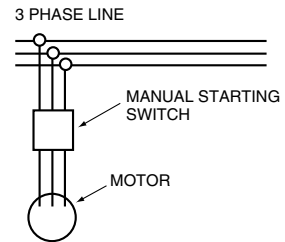

Figure 23 - THERMOSTATIC CONTROL WITH LIMIT CONTROLLER FOR THREE PHASE MOTOR

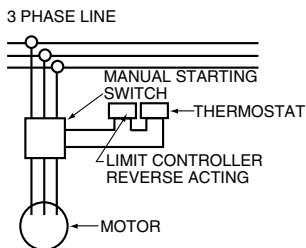
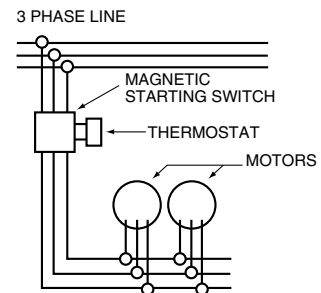

Figure 24 - THERMOSTATIC CONTROL OF SEVERAL THREE PHASE UNITS



NOTICE

1. When using a speed controller, always locate the thermostat between the speed controller and the line, not between the motor and the controller.
2. For internal wiring and overload protection on all starters, consult the control manufacturer for details.
3. When using thermostatic control with a manual starter, be sure that the electrical rating of the thermostat is sufficient to carry the motor current.

OPTIONS

VARIABLE SPEED CONTROL 115 Volt Only (optional)

The Solid State speed controller may be installed at any convenient location and is suitable for surface or flush type mounting. A standard electrical single or double gang wall box is recommended as in Figure 25.

Figure 25 - Wiring Diagram of Speed Control Installation

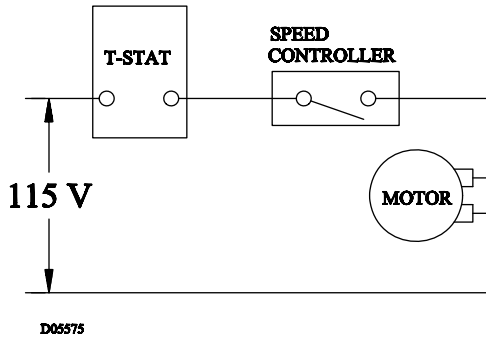

Installation procedure:

1. Attach the control's leads to the electrical leads in the control box using wire nuts. The speed control is to be wired in series with the motor. See wiring diagram in Figure 25.
2. Make certain wire nuts are tight with no copper wire being exposed.
3. Place wires and wire nuts back into box allowing room for the control to fit in box also.
4. Mount speed control to box using number 6 flathead screws provided.

Setting the control:

1. Turn the control shaft fully clockwise. If the motor is not running at the desired low speed, adjust the trim on the face of the control for low speed setting using a small screwdriver.
2. Rotate the control shaft counter clockwise. The speed will increase smoothly from minimum to maximum and then switch off.

VERTICAL LOUVER CONE DIFFUSER (optional)

Washers and bolts are provided with each louver cone diffuser. Attach the diffuser to the bottom of the unit heater as shown in Figure 26. Mounting holes are provided in the unit base plate.

Adjust the diffuser to provide the desired air pattern.

NOTICE: To meet ETL and OSHA requirements, units mounted below 8 feet (2.4m) must be equipped with an OSHA fan guard. Vertical unit heaters can support either an OSHA fan guard or the Louvered Cone Diffuser - both items cannot be installed on the same unit.

Figure 26 - Louver Cone Diffuser
Attached to Vertical Unit Heater

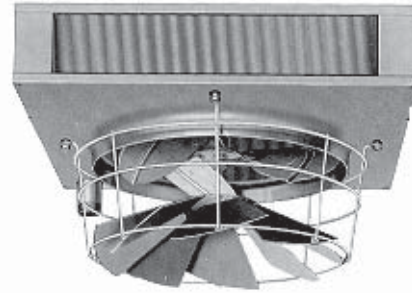

STRAP-ON WATER CONTROL

A SPDT strap-on type hot water control with 100° to 240°F (38 to 116°C) rated at 10 amps at 120V is also available. Control can be used for direct or reverse acting applications as high or low limit.

STEAM PRESSURE CONTROL

SPDT switch opens on a rise in pressure. Control is automatically reset, has a range of 0 to 15 PSI (0 to 103 kPa) and has an adjustable differential. **Other actions, ranges, circuits and manual reset models are available on request.**

THERMOSTATS

Line voltage wall thermostats are in stock for immediate shipment. All models are SPST with bimetal thermometer, knob-type set point adjustment, 40 to 90°F (5 to 30°C) range and selector switches. Standard duty models with "off-auto" and a heavy duty model with "auto-off-fan" switching are available. Other models available on request. Plastic tamperproof one size fits all thermostat guards are also available.

WALL MOUNTED SPEED CONTROLLERS

Motors up to and including 1/8 HP (115V) can be operated at reduced speeds by addition of optional speed controller. Controller is 5 amps, pre-set at factory for maximum and minimum speeds, with intermediate speeds infinitely controllable. All 1/3, 1/2 HP and 230V motors operate only at rated speed and CFM – See Charts.

MANUAL STARTERS

Single and three-phase models are available. Standard models are single-speed, toggle-operated, NEMA Type 1 and are surface-mounted.

NOTICE: When using electrical accessories, always refer to the accessory manufacturer's installation manual for proper use, location and wiring instructions.

MAINTENANCE

▲ WARNING Open all disconnect switches and secure in that position before servicing unit. Failure to do so may result in personal injury or death from electrical shock.

▲ CAUTION All rotating fans must stop before servicing to avoid serious injury to fingers and hands.

MOTOR LUBRICATION

Sleeve Bearings

Motors with oilers or oil holes are lubricated before shipment with a good grade of electric motor oil. Refill when necessary, with the motor at stand-still, until oil reaches the proper level.

Use SAE 20W non-detergent oil for motors operating in ambient temperatures of 32°F to 100°F (0°C to 38°C). Above 100°F (38°C), use an SAE 30W to SAE 50W non-detergent oil. Below 32°F (0°C), a SAE 10W non-detergent oil will be required.

The frequency of oiling will depend upon operating conditions and length of running time. Inspect the oilers or oil holes when cleaning the unit. If the unit has a fractional horse-power motor, lubricate at least once a year. Under high ambient conditions or constant fan operation, fractional horse-power motors should be lubricated every 90 days. On those motors without oilers or oil holes, follow the instructions given on the motor nameplate.

Ball Bearings

Ball bearing motors are pre-lubricated and normally not equipped with grease fittings. However, motors are equipped with removable grease plugs to allow installation of grease fittings if desired by the owner.

Motor manufacturers do not recommend or require on the job lubrication of ball bearing motors. If on the job lubrication is required by the owner, use the following procedure: With the motor at a stand-still, remove the vent and grease plugs. Install grease fitting and add grease sparingly. Remove the old grease from the vent relief chamber. Operate the motor a few minutes before reinstalling the vent plug to allow excess grease to escape. If there is evidence of grease working out around the motor shaft, less grease should be added and the greasing periods lengthened. If grease continues to appear, take the motor to the motor manufacturer's authorized service station for repair.

NOTICE: Consult local motor manufacturer's service facility for information on type of grease and oil to be used.

FAN AND MOTOR ASSEMBLY

For cleaning or maintenance purposes, the fan and motor assembly may be removed easily from the Unit Heater. The motor is attached to the fan guard which is, in turn, mounted to the top or back panel of the unit as shown in Figure 27.

On Vertical Units, reach up through the fan and remove the fan guard mounting screws. Lower the motor, fan and fan guard assembly down through the fan outlet. If desired, the top and bottom panels may be removed from the coil by taking out the four panel mounting bolts. See Figure 27.

Figure 27 – Cross Section View

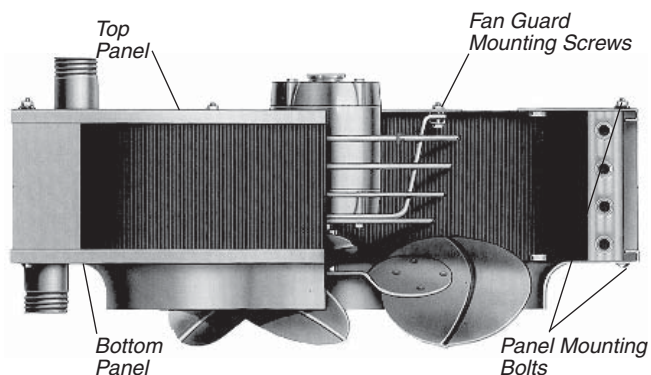

CLEANING THE UNIT

The unit casing, fan, diffuser and coil should be cleaned thoroughly once a year. Coil heat transfer efficiency depends on cleanliness. The following recommended procedures may be performed when lubricating the motor and cleaning the coil.

1. Wipe all excess lubricant from the motor, fan and casing. Clean the motor thoroughly. A dirty motor will run hot and eventually cause internal damage.
2. Clean the coil:
 - a) Loosen the dirt with a brush on the fan side of the coil. Operate the motor allowing the fan to blow the loosened dirt through the unit.
 - b) Use air pressure or steam on the side of the coil away from the fan.

NOTICE: A piece of cheesecloth or a burlap bag may be used to collect the large particles during the cleaning process.

3. Clean the casing, fan blades, fan guard and diffuser using a damp cloth. Any rust spots on the casing should be cleaned and repainted.
4. Tighten the fan guard, motor frame and fan bolts. Check the fan for clearance in the panel orifice and free rotation.

Table 20 - Troubleshooting Guide

SYMPTOMS	POSSIBLE CAUSE(S)	CORRECTIVE ACTION
A. Leaking coil.	<ol style="list-style-type: none">1. Frozen coil.2. Defective coil.3. Corrosion.4. Leak in joint.	<ol style="list-style-type: none">1. Replace.2. Replace.3. Replace4. Braze joint if joint is exposed where leak has occurred.
B. Poor output on steam.	<ol style="list-style-type: none">1. Check for air in coil.2. Lint on coil fins.	<ol style="list-style-type: none">1. Repair or replace thermostatic air vent.2. Clean coil and fins. Check filter and clean.
C. Poor output on steam or hot water.	<ol style="list-style-type: none">1. No circulation of water through coil.2. Short cycling of motor.3. Backward rotating motor.	<ol style="list-style-type: none">1. Check circulation pump. Check for blocked tubes.2. Check voltage and correct. Check for linted coil and clean. Check for defective overload and repair or replace motor.3. On single phase motor replace motor. On three phase motor, reverse two leads to change rotation.
D. Noisy or vibrating unit.	<ol style="list-style-type: none">1. Damaged fan blade.2. Dirty fan blade.	<ol style="list-style-type: none">1. Change fan blade.2. Clean fan blade.

HOW TO ORDER REPLACEMENT PARTS

Please send the following information to your local representative; If further assistance is needed, contact the manufacturer's customer service department.

- Model number
- Serial Number (if any)
- Part description and Number as shown in the Replacement Parts Catalog.

LIMITED WARRANTY

VERTICAL STEAM & HOT WATER UNIT HEATERS

The Manufacturer warrants to the original owner at the original installation site that the Vertical Steam and Hot Water Unit Heaters (the "Product") will be free from defects in material and workmanship for a period not to exceed one (1) year from startup or eighteen (18) months from date of shipment from the factory, whichever occurs first. If upon examination by the Manufacturer the Product is shown to have a defect in material or workmanship during the warranty period, the Manufacturer will repair or replace, at its option, that part of the Product which is shown to be defective.

This limited warranty does not apply:

- (a) if the Product has been subjected to misuse or neglect, has been accidentally or intentionally damaged, has not been installed, maintained or operated in accordance with the furnished written instructions, or has been altered or modified in any way.
- (b) to any expenses, including labor or material, incurred during removal or reinstallation of the defective Product or parts thereof.
- (c) to any workmanship of the installer of the Product.

This limited warranty is conditional upon:

- (a) shipment, to the Manufacturer, of that part of the Product thought to be defective. Goods can only be returned with prior written approval from the Manufacturer. All returns must be freight prepaid.
- (b) determination, in the reasonable opinion of the Manufacturer, that there exists a defect in material or workmanship.

Repair or replacement of any part under this Limited Warranty shall not extend the duration of the warranty with respect to such repaired or replaced part beyond the stated warranty period.

THIS LIMITED WARRANTY IS IN LIEU OF ALL OTHER WARRANTIES, EITHER EXPRESS OR IMPLIED, AND ALL SUCH OTHER WARRANTIES, INCLUDING WITHOUT LIMITATION IMPLIED WARRANTIES OF MERCHANTABILITY OR FITNESS FOR A PARTICULAR PURPOSE, ARE HEREBY DISCLAIMED AND EXCLUDED FROM THIS LIMITED WARRANTY. IN NO EVENT SHALL THE MANUFACTURER BE LIABLE IN ANY WAY FOR ANY CONSEQUENTIAL, SPECIAL, OR INCIDENTAL DAMAGES OF ANY NATURE WHATSOEVER, OR FOR ANY AMOUNTS IN EXCESS OF THE SELLING PRICE OF THE PRODUCT OR ANY PARTS THEREOF FOUND TO BE DEFECTIVE. THIS LIMITED WARRANTY GIVES THE ORIGINAL OWNER OF THE PRODUCT SPECIFIC LEGAL RIGHTS. YOU MAY ALSO HAVE OTHER RIGHTS WHICH MAY VARY BY EACH JURISDICTION.

In the interest of product improvement, we reserve the right to make changes without notice.

OSHA Fan Guard/Louver Cone Diffuser Installation Detail

The figures below show how both the OSHA Fan Guard and the Louver Cone Diffuser are installed on the Vertical Steam and Hot Water Unit Heater. Figures 28 and 29 detail how the louver cone diffuser and OSHA guard are attached to the unit. Figures 30 and 31 show full views of the vertical steam and hot water unit with a Louver Cone Diffuser and OSHA Fan Guard attached.

⚠ WARNING Do not mount either the Louver Cone Diffuser or OSHA Fan Guard while unit is in operation or severe personal injury may occur. Disconnect all power supplies to the unit before installing the Louver Cone Diffuser or OSHA Fan Guard.

NOTICE: To meet ETL and OSHA requirements, units mounted below 8 feet (2.4m) must be equipped with an OSHA fan guard. Vertical unit heaters can support either an OSHA fan guard or the Louvered Cone Diffuser - both items cannot be installed on the same unit.

The same screws and washers are provided with both the OSHA fan guard and Louver Cone Diffuser. The screws and washers are used in conjunction with the Nutserts to support the wire guard or diffuser to the orifice panel (bottom of vertical unit).

Figure 28 – Louver Cone Diffuser

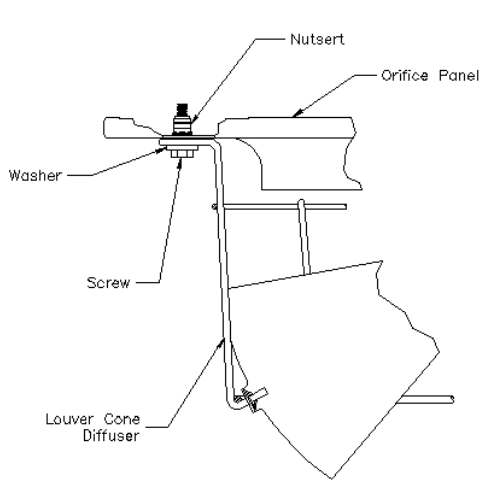

Figure 29 – OSHA Fan Guard

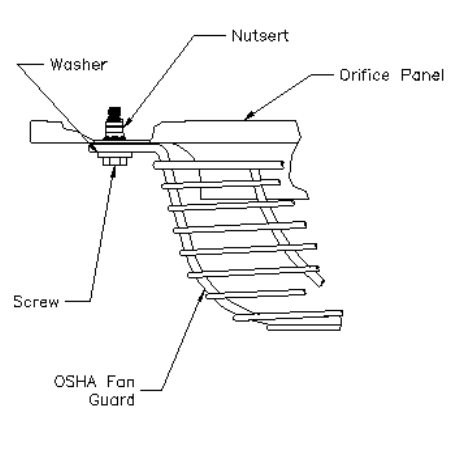

Figure 30 – Vertical Unit with Louver Cone Diffuser

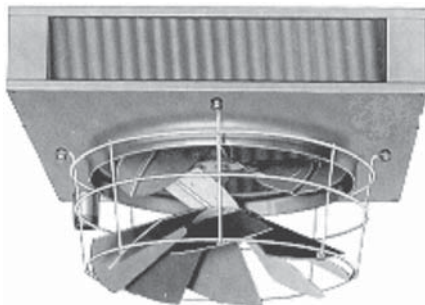

Figure 31 – Vertical Unit with OSHA Fan Guard



EQUIPMENT START-UP

Customer _____ Job Name & Number _____

PRE-INSPECTION INFORMATION

With power and water/steam off.

Type of Equipment: _____ Unit Heater

Serial Number _____ Model Number _____

Name Plate Voltage: _____ Name Plate Amperage: _____

Steam Hot Water Rating: _____ BTU @ _____ °F

_____ kw @ _____ °C

- Are all panels in place?
- Has the unit suffered any external damage? Damage _____
- Does the piping and electric wiring appear to be installed in a professional manner?
- Has the piping and electric been inspected by the local authority having jurisdiction?
- Is the supply properly sized for the equipment?
- Were the installation instructions followed when the equipment was installed?
- Have all field installed controls been installed?
- Do you understand all the controls on this equipment? *If not, contact your wholesaler or rep. (DO NOT START this equipment unless you fully understand the operation of this equipment.)*

FAN

With power on

- Check voltage L1 _____ L2 _____ L3 _____
- Check fan rotation.
- Check motor amps L1 _____ L2 _____ L3 _____