

TWIN-PAK 14

INSTALLATION INSTRUCTIONS

Installation Procedure:

1. From job schedule or plan, determine proper assemblies for each wall.
2. Install partial backplate at proper height and level (Note: Where valve compartments occur, allow 12" for partial backplate).
3. Bracket Installation: Insert carriage bolt through pitch adjustment slot in bracket assembly. Locate bracket assembly with partial backplate and screw to wall (Note: 2 bracket assemblies for enclosures 3' thru 6', and 3 brackets for 7' and 8'). Install hanger assembly with serrated flange nut and carriage bolt.
4. Lay element on floor (Note: 4 1/4 fin dimension to be horizontal). Place cradles on element and position them so that the center of the cradles will rest on the ball bearings of the hanger assemblies. Install element with cradles on hanger assemblies.
5. Install enclosure. Begin with lower enclosure. Insert the lower enclosure top bend into the armature bracket, then swing lower enclosure bottom into position with enclosure lock and tighten. Place upper enclosure top bend into partial backplate, then swing upper enclosure bottom to the armature bracket and push into place.
6. Install accessories. Accessories are the overlapping type with a bottom return to the wall. Push the top bend of the accessories down behind the partial backplate and anchor the return to the wall bend at bottom for a sturdy installation.
7. When two or more enclosures occur in a run, a 4" wall sleeve is to be used at joints.

- | | |
|-------------------------|-----------------------|
| ① ELEMENT | ⑥ BRACKET ASSEMBLY |
| ② UPPER ENCLOSURE | ⑦ PARTIAL BACKPLATE |
| ③ LOWER ENCLOSURE | ⑧ HANGER ASSEMBLY |
| ④ FASTENERS - BY OTHERS | ⑨ CARRIAGE BOLT |
| ⑤ CRADLE | ⑩ SERRATED FLANGE NUT |

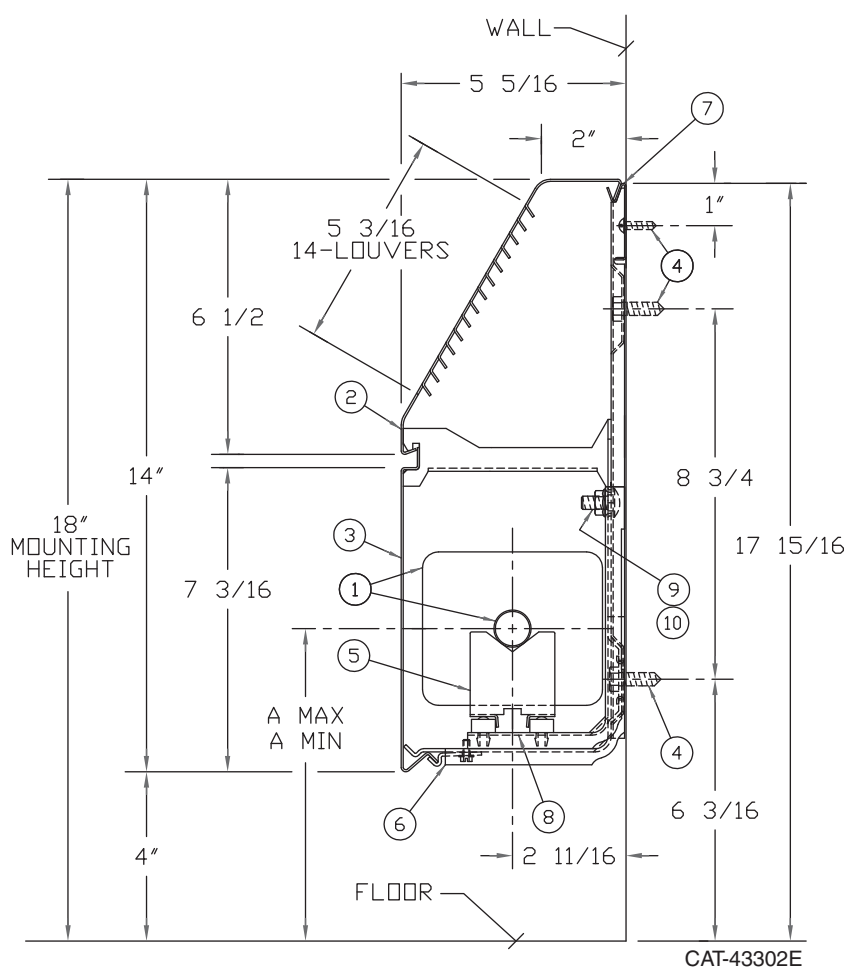

TP-14

ELEMENT CATALOG DESIGNATION	NOMINAL PIPE SIZE	CRADLE NO.	A MIN	A MAX
STC-3/4 435	3/4 COPPER	2	7 3/8	8 1/2
STC-435	1" COPPER	2	7 1/2	8 5/8
STC-1435	1 1/4 COPPER	2	7 5/8	8 13/16
ST-144	1 1/4 STEEL	2	7 7/8	8 15/16
ST-243	2" STEEL	1	7 5/8	8 3/4



260 North Elm Street • Westfield, MA 01085
 Tel: (413) 562-5423 • Fax: (413) 572-3764
 www.beacon-morris.com



TWIN-PAK 20

INSTALLATION INSTRUCTIONS

Installation Procedure:

1. From job schedule or plan, determine proper assemblies for each wall.
2. Install partial backplate at proper height and level (Note: Where valve compartments occur, allow 12" for partial backplate).
3. Bracket Installation: Insert carriage bolt through pitch adjustment slot in bracket assembly. Locate bracket assembly with partial backplate and screw to wall (Note: 2 bracket assemblies for enclosures 3' thru 6', and 3 brackets for 7' and 8'). Install hanger assembly with serrated flange nut and carriage bolt.
4. Lay element on floor (Note: 4 1/4 fin dimension to be horizontal). Place cradles on element and position them so that the center of the cradles will rest on the ball bearings of the hanger assemblies. Install element with cradles on hanger assemblies.
5. Install enclosure. Begin with lower enclosure. Insert the lower enclosure top bend into the armature bracket, then swing lower enclosure bottom into position with enclosure lock and tighten. Place upper enclosure top bend into partial backplate, then swing upper enclosure bottom to the armature bracket and push into place.
6. Install accessories. Accessories are the overlapping type with a bottom return to the wall. Push the top bend of the accessories down behind the partial backplate and anchor the return to the wall bend at bottom for a sturdy installation.
7. When two or more enclosures occur in a run, a 4" wall sleeve is to be used at joints.

- | | |
|-------------------------|-----------------------|
| ① ELEMENT | ⑥ BRACKET ASSEMBLY |
| ② UPPER ENCLOSURE | ⑦ PARTIAL BACKPLATE |
| ③ LOWER ENCLOSURE | ⑧ HANGER ASSEMBLY |
| ④ FASTENERS - BY OTHERS | ⑨ CARRIAGE BOLT |
| ⑤ CRADLE | ⑩ SERRATED FLANGE NUT |

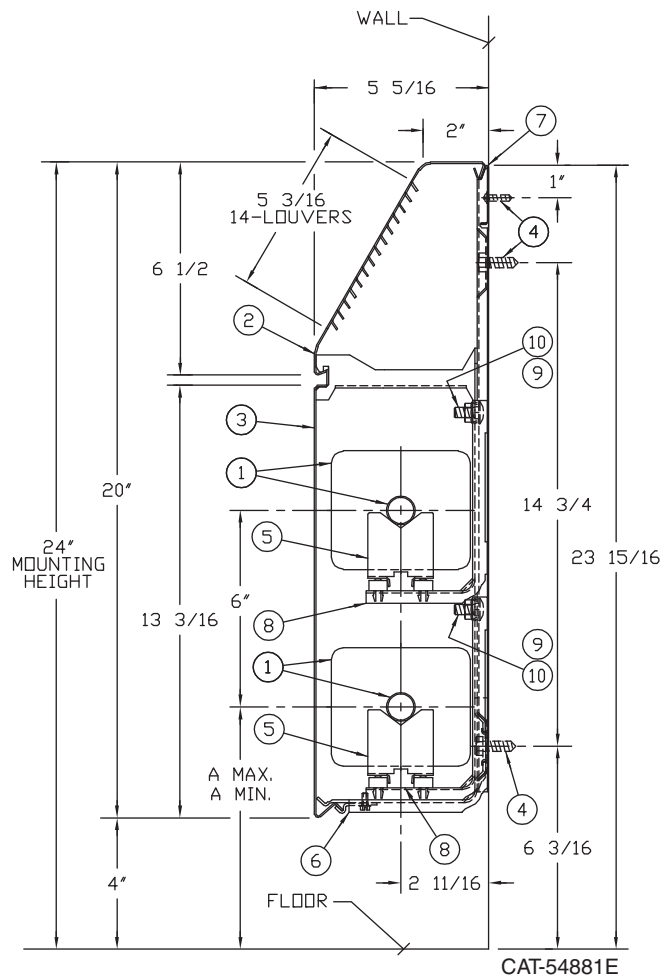

TP-20

ELEMENT CATALOG DESIGNATION	NOMINAL PIPE SIZE	CRADLE NO.	A MIN	A MAX
STC-3/4 435	3/4 COPPER	2	7 3/8	8 1/2
STC-435	1" COPPER	2	7 1/2	8 5/8
STC-1435	1 1/4 COPPER	2	7 5/8	8 13/16
ST-144	1 1/4 STEEL	2	7 7/8	8 15/16
ST-243	2" STEEL	1	7 5/8	8 3/4



260 North Elm Street • Westfield, MA 01085
 Tel: (413) 562-5423 • Fax: (413) 572-3764
 www.beacon-morris.com

