

CONVECTOR

Submittal

FWG-A
Flat Top Cabinet
Recessed
4 Sided Overlap

Specification

FWG-A Louvered Inlet

FRONT and LINER:

STYLE: Front Outlet
OUTLET: Stamped Louvers
Pencil Proof

LENGTHS: 20" thru 64" in 4" Increments

- MAT'L: Cabinet Front and Liner*
- 18 Ga./20 Ga. CRS STD.
 - 18 Ga./18 Ga. CRS (Opt'l)
 - 16 Ga./20 Ga. CRS (Opt'l)
 - 16 Ga./18 Ga. CRS (Opt'l)
 - 16 Ga./16 Ga. CRS (Opt'l)
 - 14 Ga./20 Ga. CRS (Opt'l)
 - 14 Ga./18 Ga. CRS (Opt'l)
 - 14 Ga./16 Ga. CRS (Opt'l)
 - 14 Ga./14 Ga. CRS (Opt'l)

*Liner is Galvannealed Steel

- FINISH: Prime Finish Std.
- Baked Enamel (Opt'l).
 - 18 Ga./20 Ga. SS STD.
 - 18 Ga./18 Ga. SS (Opt'l)
 - 16 Ga./20 Ga. SS (Opt'l)
 - 16 Ga./18 Ga. SS (Opt'l)
 - 16 Ga./16 Ga. SS (Opt'l)

ELEMENT:

COIL: Bronze Header 3/4" NPT
w/Copper Tube/Alum Fins
(Mechanically Expanded).

HEADER CONNECTIONS:

- Single Header Both Ends Std.
- Single Inlet 1 End / Dual Inlet 1 End (Opt'l)
- Dual Inlet Both Ends (Opt'l)

OPTIONAL ACCESSORIES:

- DAMPER: Damper Blades Factory Installed
- Knob Damper (Opt'l)
 - Tamper Resistant (Opt'l)

ACCESS DOORS:

- (Opt'l)

INSULATION:

- Back Only (Opt'l)
- Back, Sides, Top (Opt'l)

PIPING KNOCKOUT:

- (Opt'l)

4" END POCKETS:

- LH (Opt'l)
- RH (Opt'l)
- Both Ends (Opt'l)

PERFORATED FRONT: Consult Factory

- 16 Ga. (Opt'l)
- 14 Ga. (Opt'l)

FWG-A Louvered Inlet

TYPE FWG-A

TABLE					
MODEL	D	H	L	B	J
418	4-13/16	18	20,24,28,	2-1/8	4
420		20	32,36,40,		
424		24	44,48,52,		
426		26	56,60,64,		
432		32			
618	6-13/16	18	20,24,28,	3-1/8	6
620		20	32,36,40,		
624		24	44,48,52,		
626		26	56,60,64,		
632		32			
818	8-13/16	18	20,24,28,	4-1/8	8
820		20	32,36,40,		
824		24	44,48,52,		
826		26	56,60,64,		
832		32			

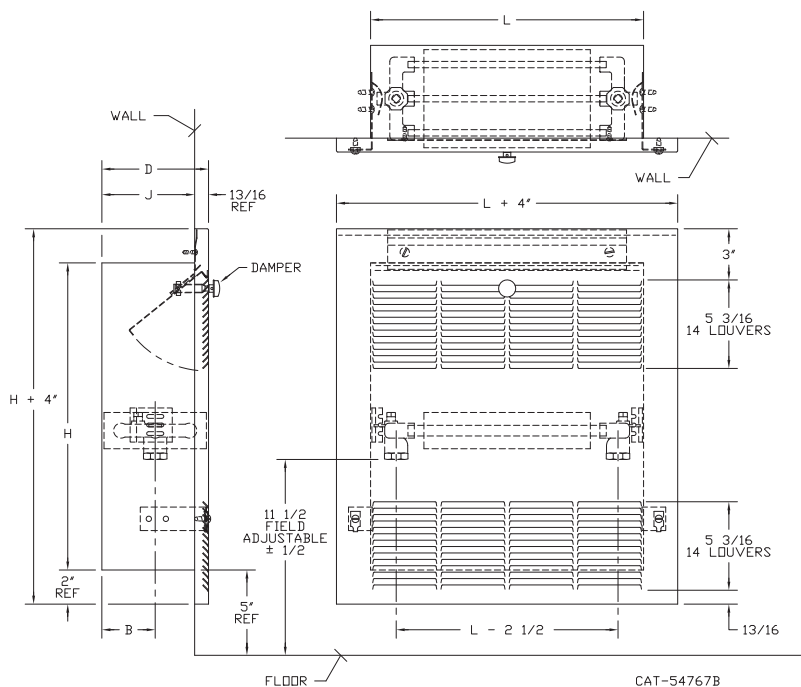

NOTE: When adding end pockets liner and front length increase.



260 North Elm St.
Westfield, MA 01085
(413) 562-5423
Fax: (413) 572-3764
www.beacon-morris.com



PROJECT: _____ DATE: _____
 LOCATION: _____
 ARCHITECT: _____
 ENGINEER: _____
 CONTRACTOR: _____
 PO NUMBER: _____

STEAM RATINGS IN BTU/H (215°F at 65° E.A.T.)

DEPTH IN INCHES	LENGTH IN INCHES	FRONT OUTLET, NOMINAL LINEAR HEIGHT *TYPES FS-A, SR-A, RF-A, PW-A				
		18"	20"	24"	26"	32"
4	20	2230	2500	2830	2950	3120
	24	2760	3120	3600	3700	3980
	28	3310	3820	4340	4460	4780
	32	3860	4460	5110	5230	5660
	36	4370	5140	5860	6000	6480
	40	4900	5760	6550	6770	7300
	44	5420	6430	7340	7510	8140
	48	5950	7080	8060	8300	8950
	52	6550	7800	8860	9070	9740
	56	7030	8400	9600	9840	10610
	60	7660	9120	10340	10610	11400
	64	8140	9740	11090	11380	12260
6		18"	20"	24"	26"	32"
	20	3240	3620	4250	4390	4850
	24	4030	4540	5350	5520	6140
	28	4850	5520	6480	6670	7370
	32	5620	6430	7560	7820	8640
	36	6430	7340	8640	9000	9910
	40	7250	8330	9770	10150	11180
	44	8060	9240	10870	11300	12410
	48	8880	10200	11980	12430	13660
	52	9740	11180	13100	13540	14900
	56	10510	12070	14160	14690	16200
	60	11400	13060	15310	15840	17420
64	12190	13990	16390	17020	18740	
8		18"	20"	24"	26"	32"
	20	4030	4540	5040	5140	5570
	24	5110	5710	6340	6550	7080
	28	6380	6960	7680	7900	8520
	32	7560	8110	9000	9260	10030
	36	8710	9310	10340	10660	11520
	40	9860	10540	11710	12020	12980
	44	11040	11760	12980	13390	14500
	48	11950	12960	14330	14740	15980
	52	13460	14230	15670	16100	17470
	56	14620	15410	17020	17500	18980
	60	15770	16660	18340	18840	20380
64	16780	17780	19680	20260	21940	

BTU ratings for FWG-A units at 215°F are obtained by applying correction factors from Table 7 to ratings shown on this page.

Correction factors for BTU performance at different Average Water Temperatures, use correction factors from Table 3 of the correction Factors page.

For other applicable Correction factors see the Correction Factors page.

CONVECTOR BTU CORRECTION FACTORS

Table 3

CONVECTOR CORRECTION FACTORS Based on ASHRAE HVAC Systems and Equipment					
AVERAGE WATER TEMPERATURE F°	ENTERING AIR TEMPERATURES °F				
	▼				
	55°	60°	STD. 65°	70°	75°
100°	0.17	0.14	0.12	0.09	0.07
110°	0.23	0.20	0.17	0.14	0.12
120°	0.29	0.26	0.23	0.20	0.17
130°	0.35	0.32	0.29	0.26	0.23
140°	0.43	0.39	0.35	0.32	0.29
150°	0.50	0.46	0.43	0.39	0.35
160°	0.58	0.54	0.51	0.47	0.43
170°	0.67	0.63	0.58	0.54	0.51
180°	0.76	0.71	0.67	0.63	0.58
190°	0.85	0.81	0.76	0.71	0.67
200°	0.95	0.90	0.85	0.81	0.76
210°	1.05	1.00	0.95	0.90	0.85
215° (STD) ▶	1.10	1.05	1.00	0.95	0.90
220°	1.15	1.10	1.05	1.00	0.95
230°	1.26	1.20	1.15	1.10	1.05
240°	1.37	1.32	1.26	1.21	1.15
250°	1.47	1.43	1.37	1.32	1.27

Table 4

CORRECTION FACTORS FOR STEAM PRESSURES OTHER THAN 1 PSI GAUGE*						
FACTOR	PRESSURE PSI GAUGE					
	5	10	15	20	25	50
	1.12	1.25	1.36	1.46	1.56	1.93

*Apply factors shown above to the ratings shown on the 215°F ratings page.

Note: Max Recommended operating pressure 150 PSIG, (365.9°F).
For conversion from steam to hot water, use correction factors shown in table 3.

Table 5

DERATING PERCENTAGE REDUCTION TABLE									
Length "L"	Free Standing, Non-Recessed Non-Standard Access Door Locations				Semi-Recessed or Recessed Non-Standard Access Door Locations				
	3 or 4	3 & 4	5 or 6	5 & 6	3 or 4	3 & 4	5 or 6	5 & 6	5 & 6
	20	6%	12%	18%	35%	2.5%	5%	7.5%	15%
24	5	9	14	28	2	4	6	12	
28	4	8	11	23	1.8	3.2	5.2	9.8	
32	3	6	11	20	1.5	2.8	4.5	8.2	
36	3	6	8	17	1.2	2.5	3.8	7.5	
40	3	5	8	15	1	2.2	3	6.8	
44	2	5	7	14	1	2	3	6	
48	2	4	6	12	1	1.8	3	5.2	
52	2	4	5	11	.8	1.5	2.2	4.5	
56	2	4	5	11	.8	1.5	2.2	4.5	
60	2	3	5	10	.8	1.5	2.2	4.5	
64	2	3	5	9	.8	1.2	2.2	3.8	

Note: Derating factors do not apply to units with end pockets.

Table 6

WATER FLOW IN G.P.M.	PRESSURE LOSS IN FEET OF WATER		
	4 INCH MODELS	6 INCH MODELS	8 INCH MODELS
.25	0.044	—	—
.50	0.160	0.070	0.046
1	0.597	0.270	0.167
2	2.220	1.047	0.616
3	—	2.260	1.367
4	—	3.793	2.380
5	—	—	3.673

Charted figures showing pressure drop through Convectors with forced hot water. Used for determining pressure head requirement. Based on 64" length units, but applicable to shorter units, as most loss is due to headers.

Table 7

DERATING FACTORS FOR INLET GRILLES			
TYPES: FSG-A, SRG-A, RFG-A, FWG-A, PWG-A, SFG-A			
HEIGHT	DEPTH		
	4	6	8
20	3%	6%	9%
24	2%	5%	7%
32	1%	2%	3%

Due to the restriction to air flow, the percentages should be subtracted from the BTU output when inlet grilles are specified.

**ADDITIONAL CORRECTION FACTORS
ON NEXT PAGE**

CONVECTOR BTU CORRECTION FACTORS

GALLONS PER MINUTE OF HOT WATER REQUIRED

Table 8

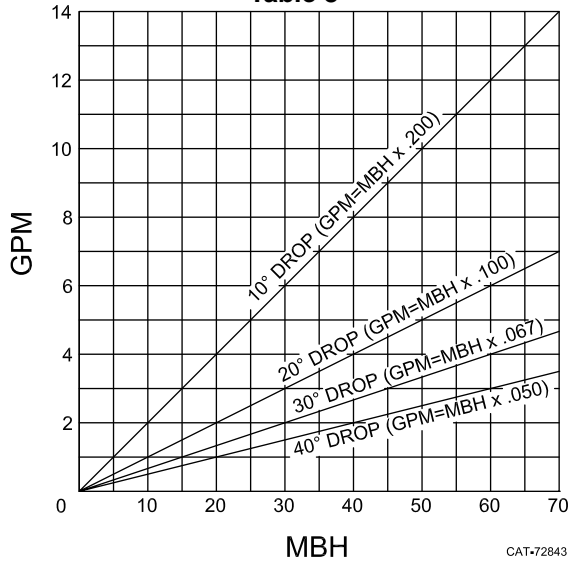

OUTPUT-FLOW RATE CORRECTIONS

Table 9

Convactor Depth	Tubes per Element	Min. Flow Rate (0.25 Ft./Sec.) GPM	MBH Based on T.D. & Min. Flow Rate			
			10TD	20TD	30TD	40TD
4	2	.15	0.750	1.500	2.250	3.000
6	3	.225	1.125	2.250	3.375	4.500
8	4	.30	1.500	3.000	4.500	6.000

NOTE: Table 9 shows MBH which result at specific water temperature drops and minimum water flow rates which are required to maintain turbulent flow within element tubes.

CONVECTOR COIL

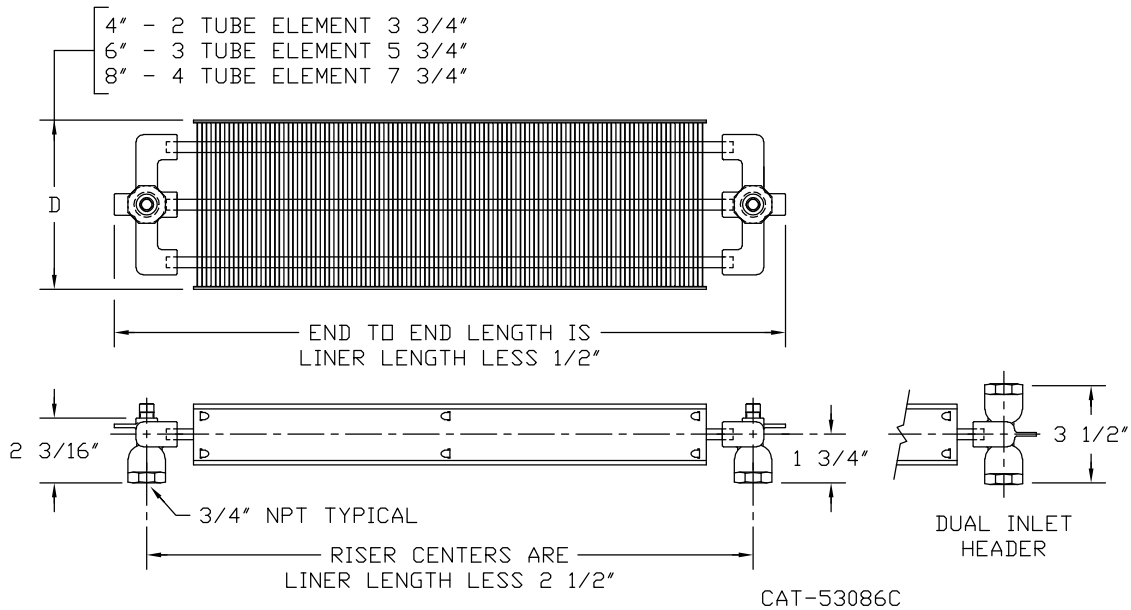

NOTE: When ordering convectors with end pockets always refer to the standard unit length. The overall physical length will increase by 4" for each end pocket. The coil length will remain the standard size. Coil fins are 2 1/2" high by width shown above and are mechanically bonded to copper tube at 6 fins per inch.

