

BEACON/MORRIS HIGH EFFICIENCY BMED/BMES GAS FIRED INDOOR DUCT FURNACES



BDFS-9

DESCRIPTION

Beacon/Morris indoor duct furnaces offer 80% thermal efficiency, High Efficiency models add annual fuel savings of 20-25%. The High Efficiency models feature spark ignition, eliminating standing pilot losses. The power venting system virtually eliminates the off-cycle loss of heated air common to conventional gravity vented heaters. Horizontal power venting allows the use of smaller, single wall vent pipe and adds savings through sidewall penetration versus roof openings. BMED models offer bottom access to burners for service and BMES models provide side access to burners for service. Both models are factory supplied with right side access to controls as standard. Only BMES models can be optionally ordered with left side control access. BMES models installed in tandem pairs should be made up of one right and one left hand model.

CERTIFICATION

Duct furnaces are designed for ducted air systems for heating, heating/cooling or make-up air and utilize a separate blower for air delivery. All Beacon/Morris duct furnaces are certified by ETL for use on natural or propane gases, installation upstream (409 stainless steel heat exchanger recommended) or downstream of cooling coils, for temperature rises of 30°F to 80°F (17-44°C) and to operate against 2.0 inches (0.5 kPa) water column pressure. All High Efficiency models are approved for use in Canada.

CAPACITIES & HEAT EXCHANGERS

Ten model capacities from 100,000 to 400,000 Btu/Hr. (29.3 to 117.1 kW) are offered and all may be ordered with heat exchangers fabricated from 20-gauge Aluminized Steel (standard) or optional types 409 or 321 Stainless Steel. We recommend the use of stainless steel heat exchangers where entering air temperature is below 40°F (4.4°C) and /or duct furnaces are located downstream from cooling coils.

STANDARD FEATURES

- * High Limit Switch
- * 115/24 Control Transformer (other voltages available)
- * Aluminized Steel Heat Exchanger, Flue Collector and Burners
- * Spark Ignited Intermittent Pilot with Electronic Flame Supervision
- * Power Venter
- * Combustion Air Pressure Switch
- * "Redundant" Single Stage Combination Valve

OPTIONAL FEATURES

- * Air Flow Prove Switch (FI)
- * 409 or 321 Stainless Steel Heat Exchangers (FI)
- * 409 Stainless Steel Burners (FI)
- * Horizontal & Vertical Louvers
- * Two Stage and Modulating Gas Controls (FI)
- * Fan Time Delay Switch (FI)
- * Summer/Winter Switch
- * Terminal Block Wiring (FI)
- * Low Ambient Control
- * Thermostats
- * High Pressure Regulator
- * Vent Caps and Adaptors
- * 409 Stainless Steel Drain Pans



(FI = Factory Installed)



260 North Elm Street • Westfield, MA 01085
Tel: (413) 562-5423 Fax: (413) 572-3764
www.beacon-morris.com



PROJECT: _____

UNIT TAG: _____

DETAILS AND DIMENSIONS



BMED Power Vented Furnace — Bottom Service Access

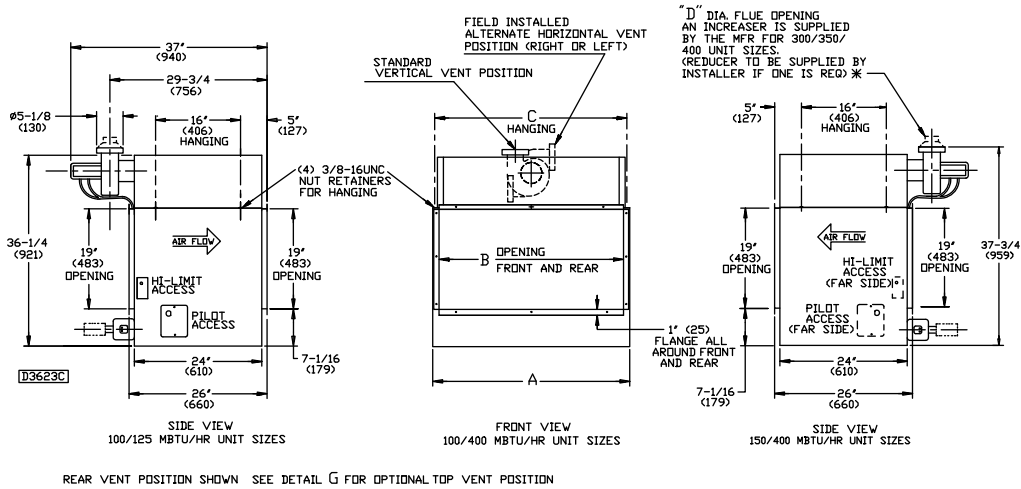
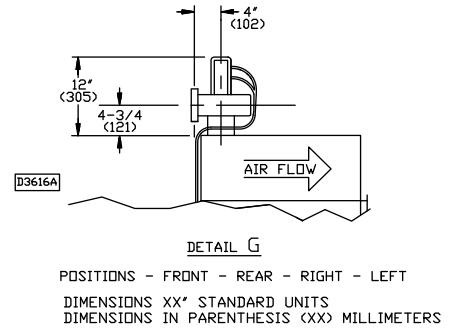
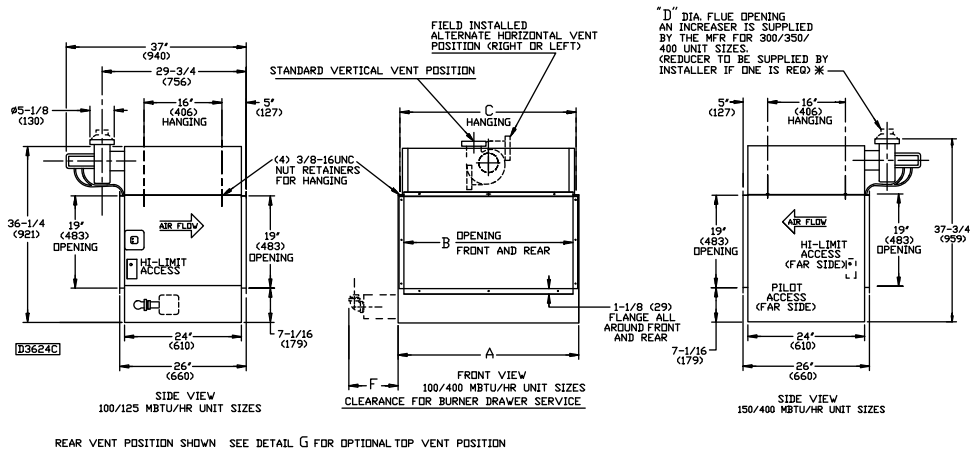

Table 2 - Power Vented Duct Furnace (BMED/BMES)

UNIT CAPACITY (MBH)	A in. (mm)	B in. (mm)	C in. (mm)	D (Dia)* in. (mm)	F in. (mm)	GAS INLET		WEIGHT lb. (kg)
						NAT.	LP	
100	17-7/8 (454)	15-1/2 (394)	17-1/8 (435)	4 (102)	23-7/8 (606)	1/2	1/2	173 (78)
125	20-5/8 (524)	18-1/4 (464)	19-7/8 (505)	4 (102)	25-5/8 (651)	1/2	1/2	186 (84)
150	20-5/8 (524)	18-1/4 (464)	19-7/8 (505)	4 (102)	26-5/8 (676)	1/2	1/2	197 (89)
175	23-3/8 (594)	21 (533)	22-5/8 (575)	4 (102)	29-3/8 (746)	1/2	1/2	216 (98)
200	26-1/8 (664)	23-3/4 (603)	25-3/8 (645)	5 (127)	32-1/8 (816)	1/2	1/2	232 (105)
225	28-7/8 (733)	26-1/2 (673)	28-1/8 (714)	5 (127)	34-7/8 (886)	3/4	1/2 OR 3/4	254 (115)
250	31-5/8 (803)	29-1/4 (743)	30-7/8 (784)	5 (127)	37-5/8 (956)	3/4	1/2 OR 3/4	263 (119)
300	37-1/8 (943)	34-3/4 (883)	36-3/8 (924)	6 (152)	43-1/8 (1095)	3/4	1/2 OR 3/4	312 (142)
350	42-5/8 (1083)	40-1/4 (1022)	41-7/8 (1064)	6 (152)	48-5/8 (1235)	3/4	1/2 OR 3/4	389 (176)
400	48-1/8 (1222)	45-3/4 (1162)	47-3/8 (1203)	6 (152)	54-1/8 (1375)	3/4	1/2 OR 3/4	403 (183)



BMES Power Vented Duct Furnace — Side Service Access



DUCT FURNACE – PERFORMANCE DATA

UNIT CAPACITY (MBH)	INPUT		OUTPUT (MBH)	MIN CFM (cu. m/s)	Temp Rise °F (°C)	PD in. of WC (kPa)	MAX CFM (cu. m/s)	Temp Rise °F (°C)	PD in. of WC (kPa)
	MAX MBH (kW)	MIN MBH (kW)							
100	100 (29.3)	50 (14.6)	80 (23.4)	929 (0.438)	80 (44)	0.12 (0.03)	2469 (1.165)	30 (17)	0.90 (0.22)
125	125 (36.6)	62.5 (18.3)	100 (29.3)	1157 (0.546)	80 (44)	0.13 (0.03)	3086 (1.457)	30 (17)	0.80 (0.20)
150	150 (43.9)	75 (22.0)	120 (35.1)	1389 (0.656)	80 (44)	0.15 (0.04)	3704 (1.748)	30 (17)	0.75 (0.19)
175	175 (51.2)	87.5 (25.6)	140 (41.0)	1620 (0.765)	80 (44)	0.14 (0.03)	4321 (2.040)	30 (17)	0.75 (0.19)
200	200 (58.6)	100 (29.3)	160 (46.9)	1852 (0.874)	80 (44)	0.14 (0.03)	4938 (2.331)	30 (17)	0.75 (0.19)
225	225 (65.9)	112.5 (32.9)	180 (52.7)	2083 (0.983)	80 (44)	0.14 (0.03)	5556 (2.622)	30 (17)	0.75 (0.19)
250	250 (73.2)	125 (36.6)	200 (58.6)	2315 (1.093)	80 (44)	0.14 (0.03)	6173 (2.914)	30 (17)	0.80 (0.20)
300	300 (87.8)	150 (43.9)	240 (70.3)	2778 (1.311)	80 (44)	0.13 (0.03)	7407 (3.496)	30 (17)	0.90 (0.22)
350	350 (102.5)	175 (51.2)	280 (82.0)	3241 (1.530)	80 (44)	0.13 (0.03)	8642 (4.079)	30 (17)	0.90 (0.22)
400	400 (117.1)	200 (58.6)	320 (93.7)	3704 (1.748)	80 (44)	0.14 (0.03)	9877 (4.662)	30 (17)	0.90 (0.22)

NOTE: Ratings shown are for unit installations at elevations between 0 and 2000 ft. (610m). For unit installations in USA above 2000 ft. (610m), the unit input must be derated 4% for each 1000 ft. (305m) above sea level; refer to local codes, or in absence of local codes, refer to the latest edition of the National Fuel Gas Code, ANSI Standard Z223.1 (N.F.P.A. No. 54). For installations in Canada, any references to deration at altitudes in excess of 2000 ft. (610m) are to be ignored. At altitudes of 2000 to 4500 ft. (610 to 1372m), the unit must be derated to 90% of the normal altitude rating, and be so marked in accordance with the CSA certification.

TEMPERATURE RISE AND PRESSURE DROP GRAPH

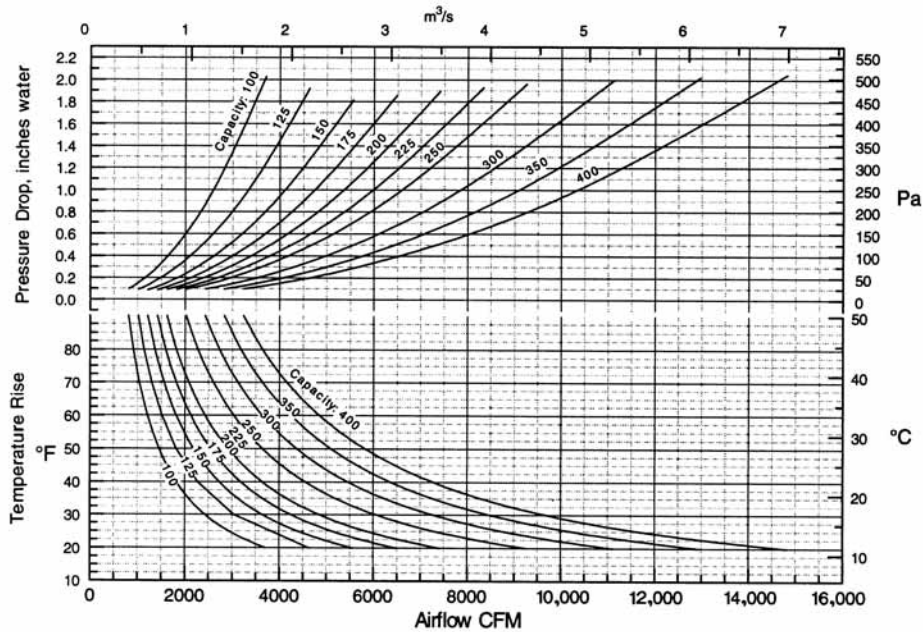

DUCT FURNACES - 1 YEAR LIMITED WARRANTY

Duct furnaces are warranted by Beacon/Morris to be free from defects in materials and workmanship for a period of one (1) year from date of shipment from Beacon/Morris' Plant.

Beacon will repair or replace, at its option, any components which, upon inspection, it finds to be defective, provided that the unit has been operated within its listed capacity, has been installed in accordance with the furnished instruction, has not been misused or subject to negligence and has received reasonable and necessary maintenance.

This warranty does not cover loss due to corrosion by chemicals precipitated in the air such as halogenated hydrocarbons.

Beacon will in no event be liable for incidental or consequential damages of any kind whatsoever.

Written permission is required prior to the return of defective components. All returns must be sent with all transportation charges prepaid to the plant designated in the written permission.