

INSTALLATION INSTRUCTIONS

NATURAL to L.P. GAS CONVERSION KIT

For 100,000-250,000 BTU/HR
Standing Pilot Unit Heaters & Duct Furnaces

Input BTU/HR	Conversion Kit No.	Orifice Size L.P.	Orifice Quantity	Original Valve (See Note)	Replacement Valve
100,000	261R06045	#54	4	VR8200A2009	N/A
125,000	261R06045	#54	5	VR8200A2009	N/A
150,000	261R06045	#54	6	VR8200A2009	N/A
175,000	261R06045	#54	7	VR8200A2009	N/A
200,000	261R06045	#54	8	VR8300A3153	N/A
225,000	261R06045	#54	9	VR8300A4045	N/A
250,000	261R06045	#54	10	VR8300A4045	N/A

Kit Contents

Main Burner Orifices (10)*
503-00054-010

Pilot Burner Orifice
BBR 11
J36-00785-014

Honeywell Gas Valve
Conversion Kit
HW# 393691
J29-04864-001

Conversion Plate
J17-02755

"Notice of Conversion" Label
J17-02754

▲ WARNING This conversion kit shall be installed by a qualified service agency in accordance with the manufacturer's instructions and all applicable codes and requirements of the authority having jurisdiction. If the information in these instructions is not followed exactly, a fire, explosion or production of carbon monoxide may result causing property damage, personal injury or loss of life. The qualified service agency performing this work assumes responsibility for the proper conversion of this appliance with this kit.

AVERTISSEMENT Cette trousse de conversion ne doit être installée que par le représentant d'un organisme qualifié et conformément aux instructions du fabricant et à tous les codes et exigences pertinentes de l'autorité compétente. Quiconque ne respecte pas à la lettre les instructions du présent guide risque de provoquer un incendie, une explosion ou des fuites de monoxyde de carbone entraînant des dommages matériels, des lésions corporelles ou la perte de vies humaines. L'organisme qualifié qui effectue les travaux est responsable de la conversion correcte de cet appareil à l'aide de cette trousse.

L.P. Gas High Altitude Orifice Chart for The United States

Elevation (ft.)	0-1,999	2,000-2,999	3,000-3,999	4,000-4,999	5,000-5,999	6,000-6,999	7,000-7,999	8,000-8,999	9,000-9,999	10,000-10,999
Orifice Size	54	54	55	55	55	55	55	56	56	56

L.P. Gas High Altitude Orifice Chart for Canada

Elevation (ft.)	0-1,999	2,000-4,500	4,501-5,500	5,501-6,500	6,501-7,500	7,501-8,500	8,501-9,500	9,501-10,500	10,501-11,500
Orifice Size	54	55	55	55	55	56	56	56	57

(1 Foot = 0.305 m)

Note: Appliances manufactured prior to May 1, 2001 may have a VR8300A3153 valve on 150 or 175 size units or a 36C03 valve on 250 size units. This kit applies to the 150 and 175 size units. Kit No. 261R06046 must be used to convert an appliance with the 36C03 valve.

*This conversion kit includes (10) main burner orifices. See the quantity of orifices required per input/heater size shown in the table above. Use only the quantity required.

**READ ALL INSTRUCTIONS COMPLETELY
BEFORE BEGINNING ANY WORK!**

1. All work must be performed by a fully qualified, experienced, and trained service technician. It is the responsibility of the installer to follow all instructions. Failure to follow these instructions could result in serious injury or property damage.
2. The qualified agency performing the work assumes responsibility for the conversion.
3. **▲ CAUTION** The gas supply shall be shut off prior to disconnecting the electrical power, before proceeding with the conversion.

****MISE EN GARDE**** Avant d'effectuer la conversion, couper d'abord l'alimentation en gaz, ensuite, couper l'alimentation électrique.
4. Wear safety glasses.
5. Wear gloves when handling the burners.
6. Be sure of ladder placement. Do not allow people to stand below or around the area where the work is being performed.
7. Do not lean ladders or equipment against the heater at any time during the conversion.

REPLACING THE ORIFICES (SEE FIGURE 1)

1. **Natural Vent and Power Vent Unit Heaters and Bottom Access Duct Furnaces-** Remove the screws holding the bottom burner access panel and remove the panel.

Side Service Duct Furnaces- Remove lower side access panel. Tag the wires on gas valve (if not already marked) and remove them from the valve. Disconnect gas supply piping from gas valve and remove piping as necessary so that burner drawer can be removed. Remove screws securing burner drawer to heat exchanger and pull burner drawer out of furnace.

2. Remove all burners one at a time by grasping the front of burner and lifting slightly. Pull the burner back, compressing the spring, and bring the front of the burner down to clear the burner bracket.

▲ CAUTION Be sure to hold onto the air shutters and springs to keep them from coming off unexpectedly and causing an injury or getting lost. Slide the burner forward to clear the main burner orifice.

3. Remove all air shutters and springs. Keep them in a box or bag until they are needed.
4. Use the proper size wrench or socket to remove the burner orifices. Remove all the natural gas orifices and keep them separated from the L.P. orifices at all times.

5. Install L.P. gas orifices in manifold, ensuring that the number stamped on the orifice matches the size listed on page one for the appliance being converted. The orifices must be installed finger tight first to avoid cross threading and the possibility of leaking. Tighten securely with wrench or socket. Do not over tighten.
6. **DO NOT INSTALL** the burners at this time. Proceed to "Replacement of Pilot Orifice".

REPLACEMENT OF PILOT ORIFICE

1. Disconnect the pilot tubing from the gas valve.
2. **Natural Vent and Power Vent Unit Heaters and Bottom Access Duct Furnaces-** Remove pilot access cover on side jacket panel. Remove the two screws holding the pilot bracket to the side panel of the burner box. Slide the bracket forward slightly to disengage the bracket from the side panel, then rotate the bottom of the bracket out and up so that the pilot assembly is upside down.

Side Service Duct Furnaces- Remove the two screws holding the pilot bracket to the burner box. Slide the pilot bracket forward slightly to disengage the bracket from the side panel and remove the pilot and bracket assembly.
3. Remove the pilot gas tubing from the pilot assembly.
4. Using a small screwdriver blade ($\frac{5}{32}$ ") or similar tool that will wedge into the orifice, insert the tool into the tubing fitting of the pilot assembly and remove the orifice.
5. Insert the L.P. gas orifice into the pilot assembly, making certain that it does not fall out before the pilot tubing is installed.
6. Install the pilot tubing finger tight first to avoid cross threading, then tighten with a wrench.
7. Reinstall the pilot assembly. Reconnect the pilot gas tubing to the gas valve.
8. Install the first main burner adjacent to the pilot assembly (see "INSTALLING THE BURNERS"). Check the dimensional relationship between the pilot and the main burner (see Figure 2).

▲ CAUTION These dimensions must be maintained for safe operation of the appliance.

INSTALLING THE BURNERS

1. Install the spring on the manifold spud.
2. Install one half of the air shutter on the burner.
3. Place the second half of the air shutter on the manifold spud and compress the spring with this half.
4. Slide the burner on the spud and keep the spring compressed with the burner.
5. Position the burner in the corresponding slot directly across from the spud the burner is on. Lift the front of the burner up and twist slightly if the burner does not slide in. Use caution not to distort the burner.
6. Completely open air shutter, then close two notches for an initial setting. Each shutter must be adjusted after the unit is started to avoid yellow tipping (see "OPERATION").
7. Replace burner access panel.
4. For altitudes above 2,000 feet (610 m), heater must be derated 4% for each 1,000 feet (305 m) above sea level. See Orifice Chart for correct orifice size for high altitude operation. High altitude orifices are not included in kit and must be ordered separately.
5. After manometers have been removed and pressure tap plugs have been reinstalled, fire the heater and check all joints for leaks using a soap solution. **Never use an open flame to check for gas leaks.**
6. The pilot flame should be $\frac{3}{4}$ to $1\frac{1}{2}$ inch (19 to 38 mm) in length (see Figure 3). To adjust the pilot flame, remove the pilot adjustment cover screw adjacent to the pilot tubing nut on the gas valve. Turn the inner screw clockwise to decrease pilot flame or counterclockwise to increase pilot flame. Replace the cover screw.
7. Allow the heater to operate for at least 5 minutes, then observe main burner flames. A hard blue flame with no lifting and no yellow tipping is normal. See Figure 4. If air shutter adjustment is necessary, close air shutter gradually until yellow tipping appears, then open just enough to eliminate the yellow tipping. **Wear gloves when handling the air shutters.**

CONVERSION OF THE GAS VALVE

1. Follow all instructions provided with the valve conversion kit. Be sure valve conversion kit is for the valve on the appliance. If the instructions are lost or not in the kit **STOP**. Call the Customer Service Department and the instructions will be faxed to you.

OPERATION

1. A water filled U-tube manometer must be used to measure gas pressures. The gauge type is not reliable and may give false readings.
2. Gas inlet pressure must be between 11.0 and 14.0 inches water column (2.7-3.5 kPa). Turn off the gas supply to the heater; connect the manometer to the pressure tap on the inlet side of the gas valve, turn on the gas and observe the pressure with the heater not firing and then firing. If the pressure is not within the specified range under both conditions, contact the gas supplier.
3. The manifold pressure must be adjusted to 10.0 inches water column (2.5 kPa). This manifold pressure applied to #54 main burner orifices assures that the input rating is correct for altitudes up to 2,000 feet (610 m). For altitudes above 2,000 feet (610 m), see (4) below. This is very critical as overfiring or underfiring can cause problems. Move the manual control on the gas valve to the "Off" position, connect the manometer to the pressure tap on the outlet side of the gas valve, turn the control on, fire the unit and adjust the pressure if necessary. To adjust the pressure, remove the cap from the pressure regulator on the gas valve, turn the regulator screw clockwise to increase pressure or counter clockwise to decrease pressure, then replace the cap.
8. After the heater is operating properly, cycle the system using the thermostat to check out the normal operating sequence of the appliance. The normal sequence is as follows: Thermostat calls for heat, opening main gas section of gas valve. Pilot ignites gas on first main burner. Flame travels along first burner to carryover slots, then travels back along each remaining main burner. When thermostat is satisfied, main gas section of the gas valve is de-energized, extinguishing main burner flames.
9. Apply conversion plate and label to heater jacket panel. The conversion plate must be installed as closely as possible to the existing heater rating plate.
▲ WARNING Gas Tightness Of The Safety Shut-Off Valves Must Be Checked On At Least An Annual Basis!

To check gas tightness of the safety shut-off valves, turn off the manual valve upstream of the appliance combination control. Remove the 1/8 inch pipe plug on the inlet side of the combination control and connect a manometer to that tapping. Turn the manual valve on to apply pressure to the combination control. Note the pressure reading on the manometer, then turn the valve off. A loss of pressure indicates a leak. If a leak is detected, use a soap solution to check all threaded connections. If no leak is found, the combination control is faulty and must be replaced before putting appliance back in service.

Figure 1

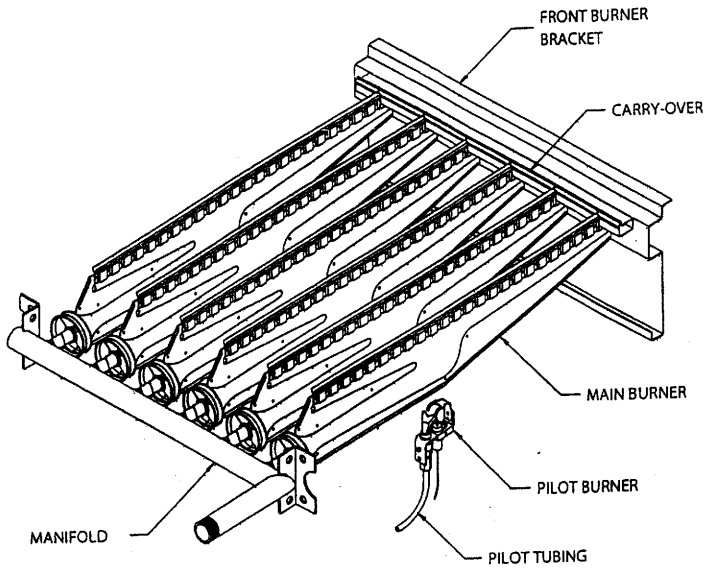

Figure 2

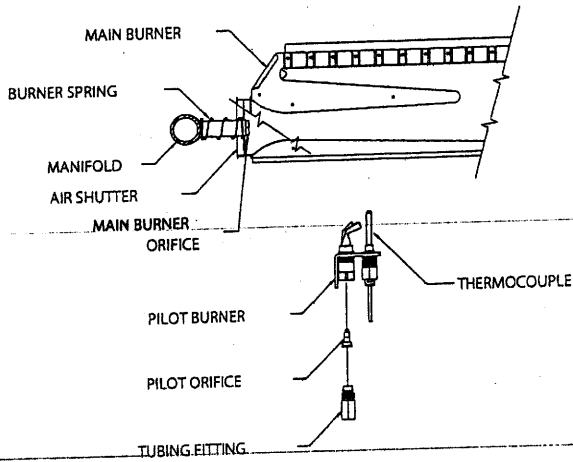
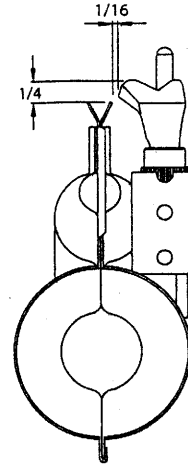

Figure 3

3/4 to 1-1/2 inch

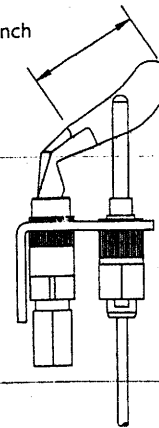

Figure 4

